

## DTM70 Series (Class I) DTM70-C8 Series (Class II) Instruction and Application Manual



### Content:

1. Product Description.....	2
2. Product Features .....	2
3. Intended Use .....	3
4. Installation Instructions .....	3
5. Recycling and Disposal Information .....	4
6. Functional Description .....	4
7. Functional Diagram.....	4
8. Product Nomenclature and List of Models .....	5
9. Short-form Data .....	6
10. Efficiency Curves.....	7
11. EMC.....	8
12. Physical Dimensions, Weight and Connectors ...	9
13. Environment.....	10
14. Isolation and Dielectric Strength.....	11
15. Safety and Protection Features .....	11
16. Approvals and Regulatory Compliances .....	12
17. Packaging Information .....	13

All parameters are typical values specified at nominal input voltage, nominal output load, 25°C ambient and after a 5 minutes run-in time unless otherwise noted. The information presented in this document is believed to be accurate and reliable and may change without notice.

For additional information, please visit <https://product.tdk.com/en/power/dtm>

## 1. PRODUCT DESCRIPTION

With the two series DTM70 and DTM70-C8 TDK-Lambda offers compact 70W medical AC-DC power adapters. Both, the DTM70 as a Class I version with protective earth on the input and the DTM70-C8 as Class II version with double insulated protection uses a robust desktop housing with the dimensions of only 120 x 52 x 31mm. Both series are members of the DTM family, whose devices are available in various power classes between 36W and 300W.

The two power adapter series are suitable for 2MOPP medical as well as for general industrial applications. The DTM70-C8 also has an IEC 60601-1-11 approval, making it ideal for medical, clinical and home healthcare applications.

All devices are approved for installation altitudes up to 5000m and EMC is tested according to IEC/EN 60601-1-2 Ed 4.

Both series are available with 12V, 15V, 18V, 24V, 36V and 48V output voltage.

Due to the high efficiencies and the low no-load losses, the devices are compliant with EU Regulation 2019/1782 (Ecodesign requirements for external power supplies) and the US DoE Level VI specification.

Special features are the compact design, achieved by the high efficiency and the standard locking DIN output connector, which prevents unintentional output voltage disconnection. Other connector versions and cable assemblies are available on request.

Safety is assured by IEC/UL/CSA/EN 60601-1 and EN 62368-1. CE and UKCA markings confirm compliance with the low voltage, EMC and RoHS directives.

## 2. PRODUCT FEATURES

- Small in size, only 120 x 52 x 31mm
- Protection Class I for DTM70 and Class II for DTM70-C8
- IEC/UL/EN 60601-1 - 2MOPP approved
- 4400Vac Input to output isolation
- IEC/EN 60601-1-2 Ed 4 (EMC) tested
- IEC/EN 60601-1-11 home healthcare approval for DTM70-C8
- IEC/BS/EN 62368-1 (I.C.T.) compliant
- Temperature range -30 to +60°C (with derating)
- AC 100-240V universal input voltage
- Locking output connector
- Operating altitude up to 5000m
- High efficiencies up to 91%
- Low no-load power consumption <150mW
- Compliant with EU Regulation 2019/1782 (ecodesign for external power supplies)
- Meets US DoE Level VI specifications

### 3. INTENDED USE

This power supply is designed for commercial use, such as in industrial control, process control, monitoring and measurement equipment or the like. It also fulfills requirements according to the medical device standard and can be used to supply certain medical devices, where this power supply is approved as part of the medical end device. Please note that compliance with the European Medical Device Directive is the responsibility of the end device manufacturer.

Do not use this device in equipment, where malfunctioning may cause severe personal injury or threaten human life without additional appropriate safety measures, that are suited for the end-application.

Do not use this device as critical component in nuclear control systems, life support systems or equipment for use in hazardous environments without the express written approval of TDK-Lambda.

If this device is used in a manner outside of its specification, the protection provided by the device may be impaired.

The device is designed for pollution degree 2 areas or for use in controlled environments.

The device is designed for altitudes up to 5000m (16400ft).

The device is designed to operate in areas with a maximum relative humidity of 93%.

### 4. INSTALLATION INSTRUCTIONS

Before operating this device, please read this manual thoroughly and retain this manual for future reference! Regardless of the place of purchase, this device must only be installed and put into operation by qualified personnel.

If damage or malfunction should occur during installation or operation, immediately turn power off and send unit to the factory or an authorized agent for inspection.

Before putting the unit into operation, check for external visible damage or noises caused by loose parts. In such cases, do not connect the device to the power source.



**WARNING** Risk of electrical shock, fire, personal injury or death.

Turn power off before working on the device. Protect against inadvertent re-powering.

Do not open, modify or repair the device. This device does not contain serviceable parts.

This device does not contain serviceable parts. Replace fuses only when explicitly permitted.

Use caution to prevent any foreign objects from entering the housing.

Do not use or store this product in environments with strong electromagnetic fields, flammable gas or ignitable substances, corrosive gases, floating conductive particles, direct sunlight, or in wet locations or areas where moisture, condensation or frost can be expected.

Do not touch during power-on, and immediately after power-off. Hot surfaces may cause burns.

Make sure that the wiring is correct by following all local and national codes.

Do not apply return voltages from the load to the output terminals.

Do not connect the outputs of multiple devices in parallel for higher output currents or in series for higher output voltages.

Do not connect batteries for charging purposes to the output of the device.

## 5. RECYCLING AND DISPOSAL INFORMATION

The device may not be disposed of as domestic refuse.

Packaging and packaging aids must be recycled or disposed in accordance with local regulations.

## 6. FUNCTIONAL DESCRIPTION

The output is electronically protected against no-load, overload and short circuit. In case of an overload or short circuit, the device will operate intermittently (hiccup mode).

The device can supply resistive and inductive loads.

Avoid loads with large input capacitances. If the capacitive load is higher than the values specified, the device operates in an intermittent mode (hiccup mode). See short-form data table for maximum values.

The output voltage is fixed and can not be adjusted.

The device is equipped with an over-temperature protection. In case of a high temperature, the output shuts down and starts automatically after cooling off.

The device is equipped with an input under-voltage protection. If the input voltage is too low, the device does not start or switches off.

In case of an internal defect, a redundant circuit prevents the output voltage from becoming excessive or dangerous.

The device is equipped with a green DC-OK LED, which is visible from the outside of the device.

## 7. FUNCTIONAL DIAGRAM

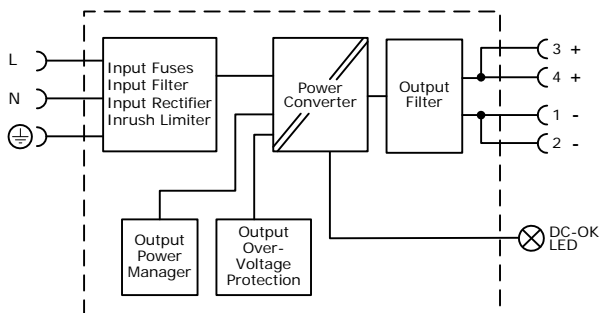

Functional diagram DTM70

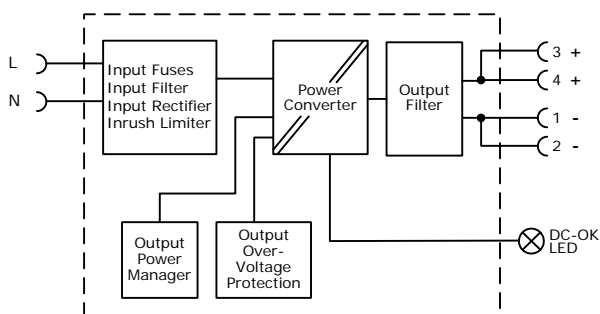

Functional diagram DTM70-C8

All parameters are typical values specified at nominal input voltage, nominal output load, 25°C ambient and after a 5 minutes run-in time unless otherwise noted. The information presented in this document is believed to be accurate and reliable and may change without notice.

For additional information, please visit <https://product.tdk.com/en/power/dtm>

## 8. PRODUCT NOMENCLATURE AND LIST OF MODELS

### Product Nomenclature:

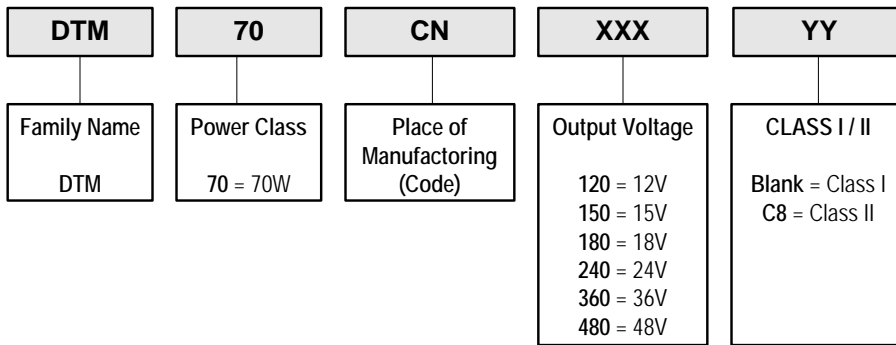

### Model list:

**DTM70CN120** External Adapter Power Supply, Class I: 70W, 12V 5.8A  
**DTM70CN150** External Adapter Power Supply, Class I: 70W, 15V 4.65A  
**DTM70CN180** External Adapter Power Supply, Class I: 70W, 18V 3.9A  
**DTM70CN240** External Adapter Power Supply, Class I: 70W, 24V 3.0A  
**DTM70CN360** External Adapter Power Supply, Class I: 70W, 36V 1.9A  
**DTM70CN480** External Adapter Power Supply, Class I: 70W, 48V 1.5A

**DTM70CN120C8** External Adapter Power Supply, Class II: 70W, 12V 5.8A  
**DTM70CN150C8** External Adapter Power Supply, Class II: 70W, 15V 4.65A  
**DTM70CN180C8** External Adapter Power Supply, Class II: 70W, 18V 3.9A  
**DTM70CN240C8** External Adapter Power Supply, Class II: 70W, 24V 3.0A  
**DTM70CN360C8** External Adapter Power Supply, Class II: 70W, 36V 1.9A  
**DTM70CN480C8** External Adapter Power Supply, Class II: 70W, 48V 1.5A

## 9. SHORT-FORM DATA

Input voltage	Nom.	AC 100-240V	
Input voltage range		80 – 264Vac	Reduce output power linearly to 80% load from 90Vac to 80Vac input (Note: Safety certified for 90-264Vac only)
Input voltage frequency range		47 – 63Hz	
Input current	Max.	1.5A	At 100Vac input, nominal load
Input inrush current	Max.	100A	At 240Vac input, cold start, 25°C ambient
Input power at no load	Max.	150mW	For all models
Power Factor	Typ.	0.58	At 100Vac input, 50Hz, nominal load
	Typ.	0.54	At 120Vac input, 60Hz, nominal load
	Typ.	0.46	At 230Vac input, 50Hz, nominal load
Output power	Nom.	70W	For all models
Output voltage setpoint	Nom.	12V ±2% (11.76–12.24V)	For DTM70CN120, DTM70CN120C8
	Nom.	15V ±2% (14.70–15.30V)	For DTM70CN150, DTM70CN150C8
	Nom.	18V ±2% (17.64–18.36V)	For DTM70CN180, DTM70CN180C8
	Nom.	24V ±2% (23.52–24.48V)	For DTM70CN240, DTM70CN240C8
	Nom.	36V ±2% (35.28–36.72V)	For DTM70CN360, DTM70CN360C8
	Nom.	48V ±2% (47.04–48.96V)	For DTM70CN480, DTM70CN480C8
			At 115/230Vac, 60% load and 25°C ambient Output voltage is not adjustable
Output current	Nom.	5.8A	For DTM70CN120, DTM70CN120C8
	Nom.	4.65A	For DTM70CN150, DTM70CN150C8
	Nom.	3.9A	For DTM70CN180, DTM70CN180C8
	Nom.	3.0A	For DTM70CN240, DTM70CN240C8
	Nom.	1.9A	For DTM70CN360, DTM70CN360C8
	Nom.	1.5A	For DTM70CN480, DTM70CN480C8
			At 115/230Vac and 25°C ambient
Line regulation	Max.	±1%	Between 90 and 264Vac
Load regulation	Max.	±5%	For DTM70CN120, DTM70CN120C8
	Max.	±3%	For DTM70CN150, DTM70CN150C8
	Max.	±2%	For all remaining models For 60% ±40% load steps
Ripple and noise voltage	Max.	120mVp-p	For DTM70CN120, DTM70CN120C8
	Max.	150mVp-p	For DTM70CN150, DTM70CN150C8
	Max.	180mVp-p	For DTM70CN180, DTM70CN180C8
	Max.	240mVp-p	For DTM70CN240, DTM70CN240C8
	Max.	360mVp-p	For DTM70CN360, DTM70CN360C8
	Max.	480mVp-p	For DTM70CN480, DTM70CN480C8
			Bandwidth 20MHz, 25degC ambient, 100nF ceramic capacitors and 10uF aluminium capacitor to output
Efficiency	Typ.	89.0%	For DTM70CN120, DTM70CN120C8
	Typ.	89.0%	For DTM70CN150, DTM70CN150C8
	Typ.	89.0%	For DTM70CN180, DTM70CN180C8
	Typ.	90.0%	For DTM70CN240, DTM70CN240C8
	Typ.	90.0%	For DTM70CN360, DTM70CN360C8
	Typ.	91.0%	For DTM70CN480, DTM70CN480C8
			At 230Vac, 75% load and 25degC ambient
Load capacitance	Max.	5800µF	For DTM70CN120, DTM70CN120C8
	Max.	4650µF	For DTM70CN150, DTM70CN150C8
	Max.	3900µF	For DTM70CN180, DTM70CN180C8
	Max.	3000µF	For DTM70CN240, DTM70CN240C8
	Max.	1900µF	For DTM70CN360, DTM70CN360C8
	Max.	1500µF	For DTM70CN480, DTM70CN480C8
			At 115/230Vac, nominal load and 25degC ambient. At larger capacitive load, the device operates in an intermittent mode.

All parameters are typical values specified at nominal input voltage, nominal output load, 25°C ambient and after a 5 minutes run-in time unless otherwise noted. The information presented in this document is believed to be accurate and reliable and may change without notice.

For additional information, please visit <https://product.tdk.com/en/power/dtm>

## External AC-DC Power Adapters, 70W

Hold-up time	Min. 8ms Typ. 10ms	For all models at 115Vac input voltage
Operational temperature range	-30°C to +60°C	For derating see chapter "Environment"
Storage temperature rang	-40°C to +85°C	
Size	120 x 52 x 31mm (4.72 x 2.05 x 1.22")	Length x Width x Height
Weight	300g (0.66lb)	Without input cable
MTBF	Min. 500 000h	Acc. to MIL HDBK 217F at full load, GB25°C
Warranty	3 years	

## 10. EFFICIENCY CURVES

**DTM70CN120, DTM70CN120C8:**

Efficiency vs. output load

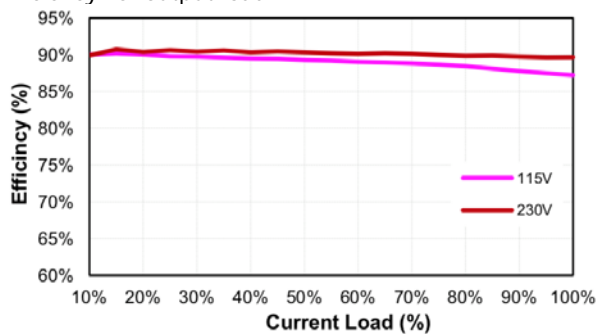

**DTM70CN150, DTM70CN150C8:**

Efficiency vs. output load

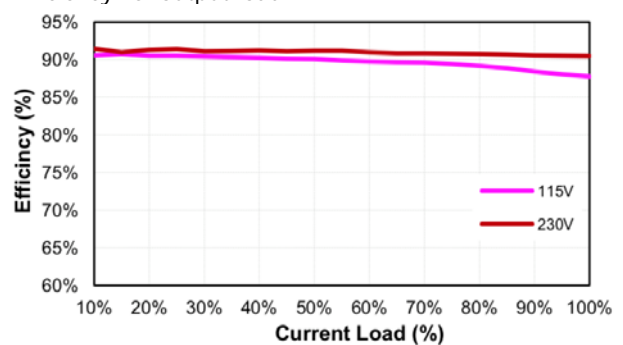

**DTM70CN180, DTM70CN180C8:**

Efficiency vs. output load

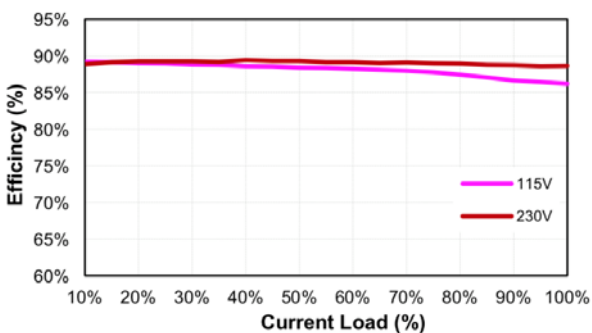

**DTM70CN240, DTM70CN240C8:**

Efficiency vs. output load

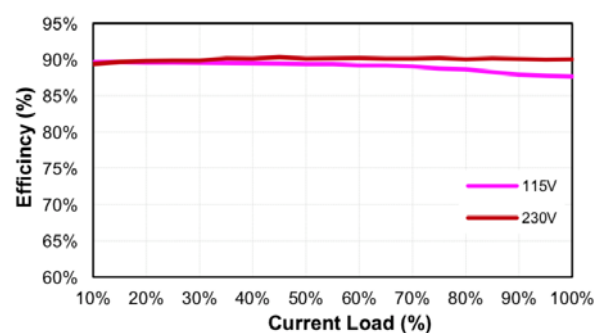

**DTM70CN360, DTM70CN360C8:**

Efficiency vs. output load

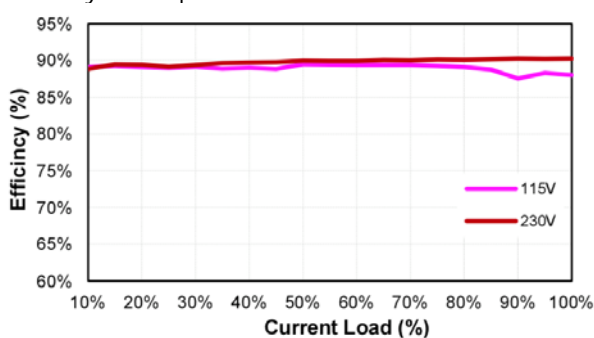

**DTM70CN480, DTM70CN480C8:**

Efficiency vs. output load

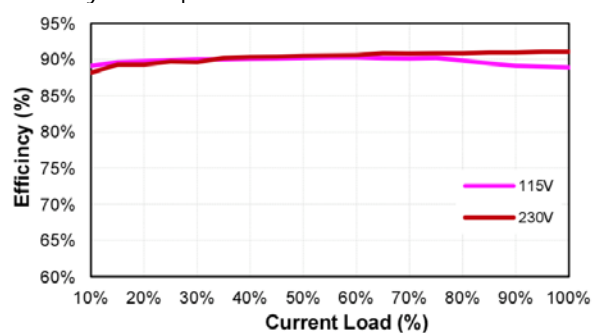

All parameters are typical values specified at nominal input voltage, nominal output load, 25°C ambient and after a 5 minutes run-in time unless otherwise noted. The information presented in this document is believed to be accurate and reliable and may change without notice.

For additional information, please visit <https://product.tdk.com/en/power/dtm>

## 11. EMC

The EMC behavior of the device is designed for applications in industrial environment as well as in residential, commercial and light industry environments.

The device is investigated according to EN 61000-6-1, EN 61000-6-2, EN 61000-6-3, EN 61000-6-4 and EN 60601-1-2.

### EMC Immunity

Electrostatic discharge	EN 61000-4-2	Contact discharge - input, output, case	±8kV (level 4)	Criterion A
		Air discharge - input, output, case	±15kV (level 4)	Criterion A
Electromagnetic RF field	EN 61000-4-3	80MHz - 1GHz	10V/m (level 3)	Criterion A
	EN 60601-1-2	1GHz – 2.7GHz	10V/m (level 3)	Criterion A
		2.7GHz - 6GHz	10V/m (level 3)	Criterion A
		380MHz to 5.8GHz (Spot frequencies)	9-28V/m as per table 9 in standard	Criterion A
Fast transients (Burst)	EN 61000-4-4	Input lines:	±2kV (level 3)	Criterion A
		Output lines	±2kV (level 3)	Criterion A
Surge voltage	EN 61000-4-5	Input lines: L → N	±1kV (level 3)	Criterion A
		L → PE <sup>1)</sup> , N → PE <sup>1)</sup>	±2kV (level 3)	Criterion A
Conducted disturbance	EN 61000-4-6	0.15-80MHz - input, output	10V (level 3)	Criterion A
Power frequency magnetic field	EN 61000-4-8	Applied to enclosure	30A/m continuous 300A/m up to 3s	Criterion A Criterion A
Mains voltage dips	EN 61000-4-11, EN 60601-1-2	AC 100V	0Vac, ½ cycle (class 3)	Criterion A
			0Vac, 1 cycle (class 3)	Criterion A
			40Vac, 10/12 cycles (class 3)	Criterion B
			70Vac, 25/30 cycles (class 3)	Criterion A
			80Vac, 250/300 cycles (class 3)	Criterion A
Voltage interruptions	EN 61000-4-11, EN 60601-1-2	AC 100/120/230Vac	0Vac, 250/300 cycles (class 3)	Criterion B

**1)** For DTM70 Class I versions only

### Performance criterions:

- A:** Unit remains within main specification throughout testing, signals remains correct and output voltage fluctuation is less than ±5%.
- B:** Unit performance drops below specification during testing, but recovers after the test without user intervention
- C:** Unit performance drops below specification during testing, and requires user intervention to recover

### EMC Emission

Conducted emission input lines	EN 55011	Class B	Group 1
	EN 55032	Class B	
	FCC 47 CFR Ch1. Part 18.309(b)	N/A	Not registered but tested
Radiated emission	EN 55011	Class B	Group 1
	EN 55032	Class B	
	FCC 47 CFR Ch1. Part 18.305	N/A	Not registered but tested
Harmonic input current	EN 61000-3-2	Fulfilled	For class A equipment
Voltage fluctuations, flicker	EN 61000-3-3	Fulfilled	d <sub>max</sub> only, other aspects require test at system level

### Switching Frequency

Main converter	Typ. 65kHz	Constant switching frequency
----------------	------------	------------------------------

All parameters are typical values specified at nominal input voltage, nominal output load, 25°C ambient and after a 5 minutes run-in time unless otherwise noted. The information presented in this document is believed to be accurate and reliable and may change without notice.

For additional information, please visit <https://product.tdk.com/en/power/dtm>



## 12. PHYSICAL DIMENSIONS, WEIGHT AND CONNECTORS

Length	120mm (4.72")
Width	52mm (2.05")
Height	31mm (1.22")
Weight	300g (0.66lb)
Case material	Polycarbonate

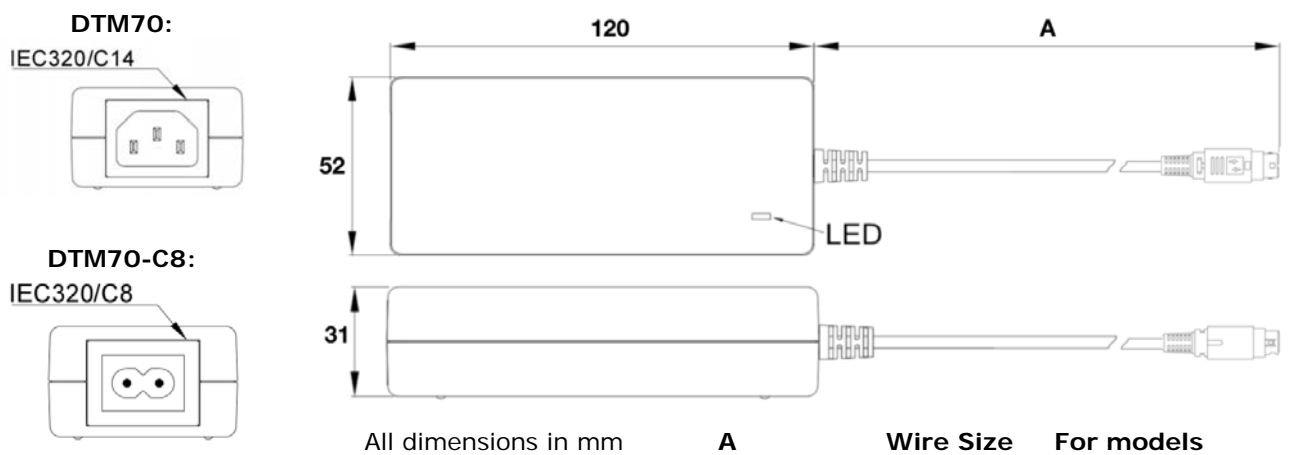

All dimensions in mm	A	Wire Size	For models
	1220mm	16AWG	12V and 15V
	1800mm	16AWG	18V
	1800mm	18AWG	24V, 36V and 48V

### Output Connector

Kycon KPPx-4P  
(or equivalent)

**P1, P2:** -Vout  
**P3, P4:** +Vout

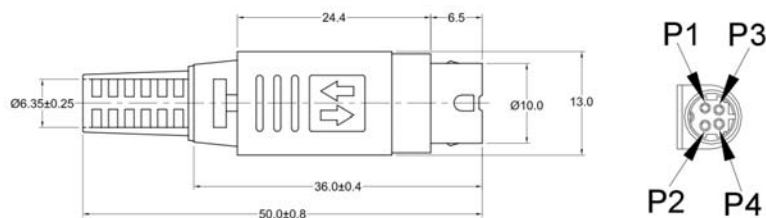

Alternative output connectors are available  
Please contact sales for further information (minimum quantities apply)

All parameters are typical values specified at nominal input voltage, nominal output load, 25°C ambient and after a 5 minutes run-in time unless otherwise noted. The information presented in this document is believed to be accurate and reliable and may change without notice.

For additional information, please visit <https://product.tdk.com/en/power/dtm>

### 13. ENVIRONMENT

Operational temperature	-30°C to +60°C (-22°F to 140°F)	Operational temperature is the ambient or surrounding temperature of the device
Storage temperature	-40°C to +85°C (-40°F to 185°F)	For storage and transportation
Output de-rating	1.75W/°C The de-rating is not hardware controlled. The user has to take this into consideration to stay below the de-rated current limits in order not to overload the unit.	Between +40°C and +60°C
Humidity	Max 93% r.h.	According to IEC 60068-2-30
Atmospheric pressure	110-54kPa	
Altitude	Up to 5000m (16 400ft)	
Over-voltage category	II	According to IEC 60664-1
Degree of pollution	2	According to IEC 62477-1, not conductive
Vibration sinusoidal	4g 15-2000Hz 60 minutes per axis	According MIL-STD-810F Table 514.5C-VIII, sinusoidal vibration, units are operational
Shock	75 g, 10 ms 18 shocks 3 shocks for each ±axis	According MIL-STD-810F Table 516.5-I units are operational

Allowed output load vs. ambient temp.

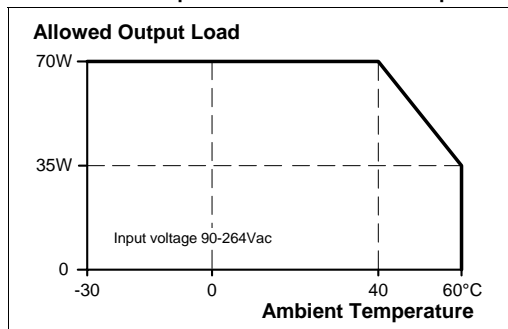

All parameters are typical values specified at nominal input voltage, nominal output load, 25°C ambient and after a 5 minutes run-in time unless otherwise noted. The information presented in this document is believed to be accurate and reliable and may change without notice.

For additional information, please visit <https://product.tdk.com/en/power/dtm>

### 14. ISOLATION AND DIELECTRIC STRENGTH

The output voltage is floating and has no ohmic connection to the input or PE.

Hi-pot tests may be repeated by the customer using appropriate test equipment, which applies the voltage with a slow ramp (2s up and 2s down). Connect all input-terminals together as well as all output poles before conducting the test.

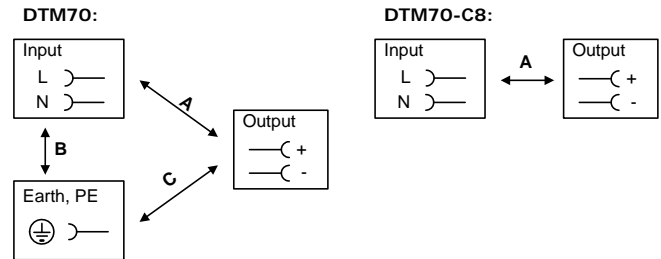

		DTM70	DTM70-C8	
Dielectric strength	Min.	4400Vac	4400Vac	Input to output (A) for 1 minute
	Min.	1800Vac	-	Input to PE (B) for 1 minute
	Min.	1800Vac	-	Output to PE (C) for 1 minute
Isolation resistance	Min.	100MΩ	100MΩ	Input to output (A)

### 15. SAFETY AND PROTECTION FEATURES

Under voltage protection (UVP)	Min.	60Vac	For all models
Shut-down voltage	Typ.	65Vac	
	Max.	70Vac	
Output over voltage protection (OVP)	Typ.	13.5V	For DTM70CN120, DTM70CN120C8
	Typ.	16.5V	For DTM70CN150, DTM70CN150C8
	Typ.	19.5V	For DTM70CN180, DTM70CN180C8
	Typ.	26.0V	For DTM70CN240, DTM70CN240C8
	Typ.	40.0V	For DTM70CN360, DTM70CN360C8
	Typ.	53.5V	For DTM70CN480, DTM70CN480C8
			In case of an internal defect, a redundant circuit limits the maximum output voltage. The output shuts down and automatically attempts to restart.
Output over-current protection (OCP)	Min.	130%	Of the nominal output current, auto recovery
	Max.	150%	
Output short-circuit protection (SCP)		Included	Continuous, automatic recovery
Class of protection		I	For all DTM70
		II	For all DTM70-C8
			According to IEC 61140
Degree of protection		IP 21	According to EN/IEC 60529
Input transient protection		MOV	For protection values see EMC chapter.
Internal input fuse		Included	Not user replaceable slow-blow high-braking capacity fuse
Earth leakage current	Max.	300μA	For DTM70
Touch current	Max.	90μA	For DTM70 and DTM70-C8

All parameters are typical values specified at nominal input voltage, nominal output load, 25°C ambient and after a 5 minutes run-in time unless otherwise noted. The information presented in this document is believed to be accurate and reliable and may change without notice.

For additional information, please visit <https://product.tdk.com/en/power/dtm>

## 16. APPROVALS AND REGULATORY COMPLIANCES

CE	EU Declaration of Conformity includes Low-Voltage, EMC and RoHS Directive
UKCA	UK Declaration of Conformity includes Electrical Safety, EMC and RoHS Directive
IEC 60601-1:ED3 IEC 60601-11:2015	Medical electrical equipment Part 1: General requirements for basic safety and essential performance Part 1-11: Collateral Standard: Requirements for medical electrical equipment and medical electrical systems used in the home healthcare environment (DTM70-C8 only)
UL 60601-1:ED3	UL Certificate Recognized component for category QOHM2 and QOHM8 - Medical electrical equipment Applicable for US and Canada E-File: E349607
EN 60601-1:2016;A1 EN 60601-1-6:2010;A1	<u>For DTM70:</u> Medical electrical equipment Part 1: General requirements for basic safety and essential performance Part 1-6: Collateral standard: Usability Nemko Certificate P21224688
EN 60601-1:2016;A1 EN 60601-1-6:2010;A1 EN 60601-1-11:2015 EN 60601-1-2:2015	<u>For DTM70-C8:</u> Medical electrical equipment Part 1: General requirements for basic safety and essential performance Part 1-6: Collateral standard: Usability Part 1-11: Collateral Standard: Requirements for medical electrical equipment and medical electrical systems used in the home healthcare environment Part 1-2: Collateral Standard: Electromagnetic disturbances - Requirements and tests Nemko Certificate P21225419
IEC/BS/EN 62368-1	Compliant with safety requirements for audio/video, information and communication technology equipment
ErP Directive	Compliant with EU Regulation 2019/1782 (Ecodesign requirements for external power supplies)
DoE Level	Compliant with the US DoE Level VI specification
REACH Directive	Directive 1907/2006/EU of the European Parliament and the Council of June 1st, 2007 regarding the Registration, Evaluation, Authorisation and Restriction of Chemicals (REACH)

All parameters are typical values specified at nominal input voltage, nominal output load, 25°C ambient and after a 5 minutes run-in time unless otherwise noted. The information presented in this document is believed to be accurate and reliable and may change without notice.

For additional information, please visit <https://product.tdk.com/en/power/dtm>

## 17. PACKAGING INFORMATION

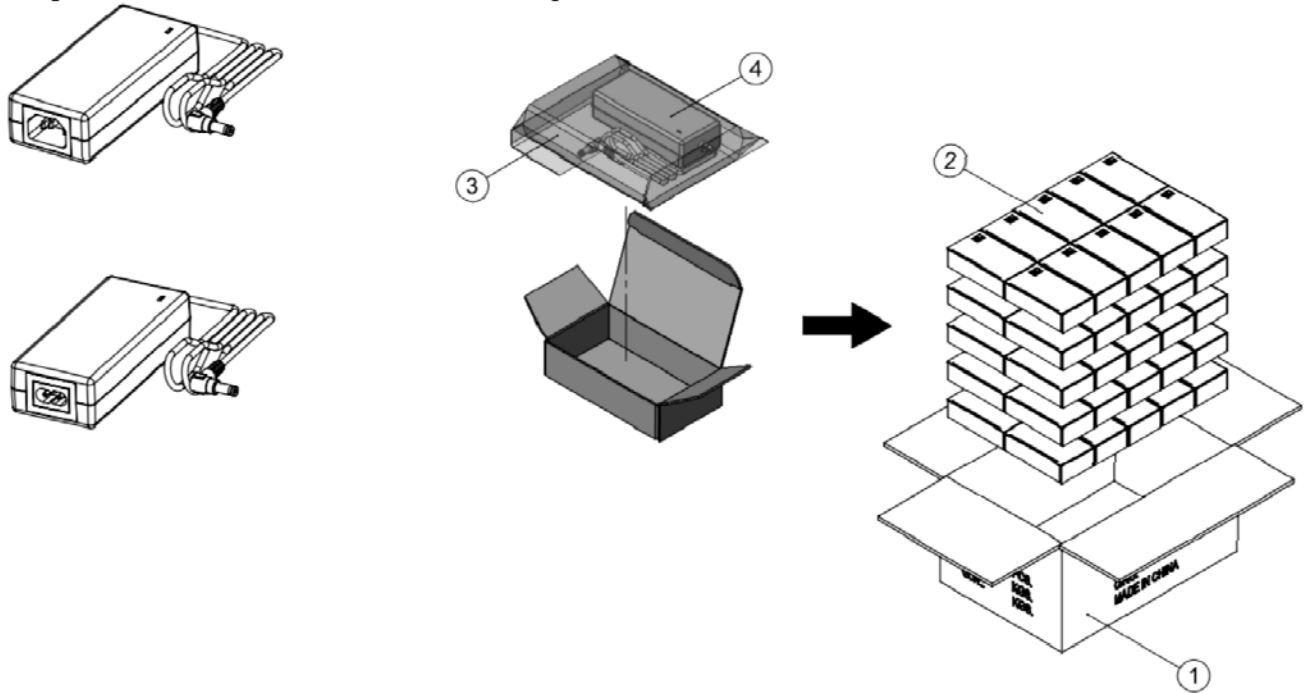

1	Cardboard Box	455x318x230mm	1pc
2	Inner Box	150x85x40mm	50pcs
3	Plastic Bag	155x245x0.08mm	50pcs
4	Product	120x52x31mm	50pcs
Net weight		15.0kg	
Gross weight		17.5kg	

All parameters are typical values specified at nominal input voltage, nominal output load, 25°C ambient and after a 5 minutes run-in time unless otherwise noted. The information presented in this document is believed to be accurate and reliable and may change without notice.

For additional information, please visit <https://product.tdk.com/en/power/dtm>