

# DELIVERY SPECIFICATION

SPEC. No. A-ESD-c

D A T E : Jun, 2019

To

**Non-Controlled Copy**

CUSTOMER'S PRODUCT NAME

TDK PRODUCT NAME

MULTILAYER CERAMIC CHIP CAPACITORS  
Bulk and Tape packaging 【RoHS compliant】  
CGA3EA ESD Protection Series

Please return this specification to TDK representatives with your signature.  
If orders are placed without returned specification, please allow us to judge that specification is accepted by your side.

## RECEIPT CONFIRMATION

DATE: \_\_\_\_\_ YEAR \_\_\_\_\_ MONTH \_\_\_\_\_ DAY \_\_\_\_\_

Test conditions in this specification based on AEC-Q200 for automotive application.

TDK Corporation  
Sales  
Electronic Components  
Sales & Marketing Group

Engineering  
Electronic Components Business Company  
Ceramic Capacitors Business Group

APPROVED	Person in charge

APPROVED	CHECKED	Person in charge

**CATALOG NUMBER CONSTRUCTION**

<b>CGA</b>	<b>3</b>	<b>E</b>	<b>A</b>	<b>NP0</b>	<b>2A</b>	<b>103</b>	<b>J</b>	<b>080</b>	<b>A</b>	<b>C</b>
(1)	(2)	(3)	(4)	(5)	(6)	(7)	(8)	(9)	(10)	(11)

(1) Series

(2) Dimensions L x W (mm)

Code	EIA	Length	Width	Terminal width
3	CC0603	1.60	0.80	0.20

(3) Thickness code

Code	Thickness
E	0.80 mm

(4) Function identification code

Symbol	Condition
A	ESD protection

(5) Temperature characteristics

Temperature characteristics	Temperature coefficient	Temperature range
C0G	0±30 ppm/°C	-55 to +125°C
NP0	0±30 ppm/°C	-55 to +150°C

(6) Rated voltage (DC)

Code	Voltage (DC)
2A	100V

(7) Nominal capacitance (pF)

The capacitance is expressed in three digit codes and in units of pico Farads (pF). The first and second digits identify the first and second significant figures of the capacitance. The third digit identifies the multiplier. R designates a decimal point.

(Example)0R5 = 0.5pF  
 101 = 100pF  
 225 = 2,200,000pF = 2.2µF

(8) Capacitance tolerance

Code	Tolerance
J	±5%

(9) Thickness

Code	Thickness
080	0.80 mm

(10) Packaging style

Code	Style
A	178mm reel, 4mm pitch

(11) Special reserved code

Code	Description
A,C	TDK internal code

1. SCOPE

This specification is applicable to chip type multilayer ceramic capacitors with a priority over the other relevant specifications.

Production places defined in this specification shall be TDK Corporation Japan, TDK(Suzhou)Co.,Ltd and TDK Components U.S.A. Inc.

EXPLANATORY NOTE:

This specification warrants the quality of the ceramic chip capacitor. Capacitors should be evaluated or confirmed a state of mounted on your product.

If the use of the capacitors goes beyond the bounds of this specification, we can not afford to guarantee.

2. CODE CONSTRUCTION

(Example) CGA 3 E A C0G 2 A 103 J T 0000  
 (1) (2) (3) (4) (5) (6) (7) (8) (9) (10)

(1) Series

Symbol	Series
CGA	Ceramic chip capacitor for automotive application

(2) Type

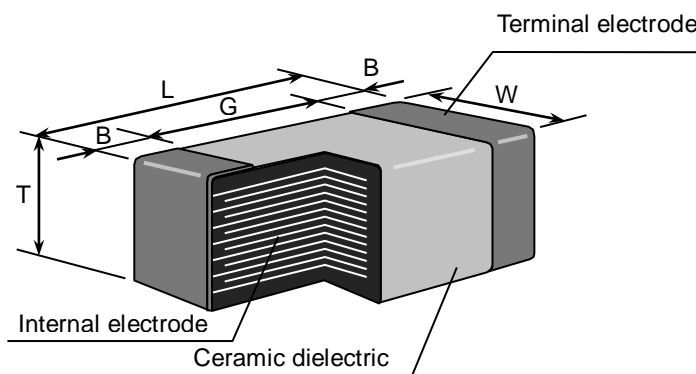

Symbol	Type	Dimensions (Unit : mm)				
	TDK(EIA style)	L	W	T	B	G
3	CGA3(CC0603)	1.60±0.10	0.80±0.10	0.80±0.10	0.20 min.	0.30 min.

(3) Thickness

Symbol	Dimension(mm)
E	0.80

(4) Identification for ESD capacitor

\* Details are shown in table 1 No.16 at 6.PERFORMANCE.

Symbol	Identification
A	ESD capacitor

※ As for applied ESD level, please refer to product catalog on TDK Web.

(5) Temperature Characteristics

\* Details are shown in table 1 No.6 at 6.PERFORMANCE.

(6) Rated Voltage

Symbol	Rated Voltage
2 A	DC 100 V

(7) Rated Capacitance

Stated in three digits and in units of pico farads (pF). The first and Second digits identify the first and second significant figures of the capacitance, the third digit identifies the multiplier.

(Example)

Symbol	Rated Capacitance
103	10,000 pF

(8) Capacitance tolerance

Symbol	Tolerance
J	± 5 %

(9) Packaging

Symbol	Packaging
B	Bulk
T	Taping

(10) TDK internal code

## 3. OPERATING TEMPERATURE RANGE

T.C.	Min. operating Temperature	Max. operating Temperature	Reference Temperature
C0G	-55°C	125°C	25°C
NP0	-55°C	150°C	25°C

## 4. STORING CONDITION AND TERM

5 to 40°C at 20 to 70%RH  
6 months Max. upon receipt.

## 5. INDUSTRIAL WASTE DISPOSAL

Dispose this product as industrial waste in accordance with the Industrial Waste Law.

6. PERFORMANCE

table 1

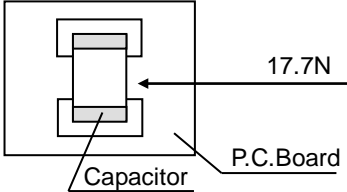
No.	Item	Performance	Test or inspection method								
1	External Appearance	No defects which may affect performance.	Inspect with magnifying glass(3x)								
2	Insulation Resistance	10,000MΩ min.	Apply rated voltage for 60s.								
3	Voltage Proof	Withstand test voltage without insulation breakdown or other damage.	3 times of rated voltage Above DC voltage shall be applied for 1s. Charge / discharge current shall not exceed 50mA.								
4	Capacitance	Within the specified tolerance.	<table border="1"> <thead> <tr> <th>Rated Capacitance</th> <th>Measuring frequency</th> <th>Measuring voltage</th> </tr> </thead> <tbody> <tr> <td>1000pF</td> <td>1MHz±10%</td> <td rowspan="2">0.5 ~ 5V rms.</td> </tr> <tr> <td>Over 1000pF</td> <td>1kHz±10%</td> </tr> </tbody> </table>	Rated Capacitance	Measuring frequency	Measuring voltage	1000pF	1MHz±10%	0.5 ~ 5V rms.	Over 1000pF	1kHz±10%
Rated Capacitance	Measuring frequency	Measuring voltage									
1000pF	1MHz±10%	0.5 ~ 5V rms.									
Over 1000pF	1kHz±10%										
5	Q	Please refer to detail page on TDK Web.	See No.4 in this table for measuring condition.								
6	Temperature Characteristics of Capacitance	<table border="1"> <thead> <tr> <th>T.C.</th> <th>Temperature Coefficient (ppm/°C)</th> </tr> </thead> <tbody> <tr> <td>C0G</td> <td>0 ± 30</td> </tr> <tr> <td>NP0</td> <td>0 ± 30</td> </tr> </tbody> </table> <p>Capacitance drift within ± 0.2% or ± 0.05pF, whichever larger.</p>	T.C.	Temperature Coefficient (ppm/°C)	C0G	0 ± 30	NP0	0 ± 30	<p>Temperature coefficient shall be calculated based on values at 25°C and 85°C temperature.</p> <p>Measuring temperature below 25°C shall be -10°C and -25°C.</p>		
T.C.	Temperature Coefficient (ppm/°C)										
C0G	0 ± 30										
NP0	0 ± 30										
7	Robustness of Terminations	No sign of termination coming off, breakage of ceramic, or other abnormal signs.	<p>Reflow solder the capacitors on a P.C.Board shown in Appendix 2 and apply a pushing force of 17.7N with 10±1s.</p>  <p>The diagram illustrates a capacitor mounted on a P.C. Board. A horizontal arrow labeled '17.7N' points to the capacitor, indicating the force applied during the test. The capacitor is labeled 'Capacitor' and the board is labeled 'P.C.Board'.</p>								

(continued)

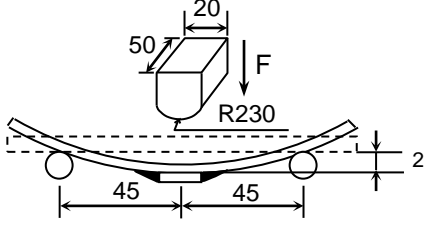
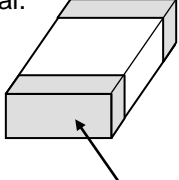
No.	Item	Performance	Test or inspection method																			
8	Bending	No mechanical damage.	Reflow solder the capacitor on a P.C.Board shown in Appendix1 and Bend it for 2mm.  (Unit : mm)																			
9	Solderability	New solder to cover over 75% of termination. 25% may have pin holes or rough spots but not concentrated in one spot. Ceramic surface of A sections shall not be exposed due to melting or shifting of termination material.  A section	Completely soak both terminations in solder at the following conditions.  Solder : Sn-3.0Ag-0.5Cu or Sn-37Pb Temperature : 245±5°C(Sn-3.0Ag-0.5Cu) 235±5°C(Sn-37Pb) Soaking time : 3±0.3s(Sn-3.0Ag-0.5Cu) 2±0.2s(Sn-37Pb)  Flux: Isopropyl alcohol (JIS K 8839) Rosin (JIS K 5902) 25% solid solution.																			
10	Resistance to solder heat	<table border="1" data-bbox="375 1093 946 1787"> <tr> <td data-bbox="375 1093 523 1189">External appearance</td> <td colspan="2" data-bbox="523 1093 946 1189">No cracks are allowed and terminations shall be covered at least 60% with new solder.</td> </tr> <tr> <td data-bbox="375 1189 523 1400">Capacitance</td> <td data-bbox="523 1189 715 1400"> <table border="1"> <tr> <th>Characteristics</th> <th>Change from the value before test</th> </tr> <tr> <td>C0G NPO</td> <td>±2.5%</td> </tr> </table> </td> <td data-bbox="715 1189 946 1400"></td> </tr> <tr> <td data-bbox="375 1400 523 1496">Q</td> <td colspan="2" data-bbox="523 1400 946 1496">Meet the initial spec.</td> </tr> <tr> <td data-bbox="375 1496 523 1585">Insulation Resistance</td> <td colspan="2" data-bbox="523 1496 946 1585">Meet the initial spec.</td> </tr> <tr> <td data-bbox="375 1585 523 1787">Voltage proof</td> <td colspan="2" data-bbox="523 1585 946 1787">No insulation breakdown or other damage.</td> </tr> </table>	External appearance	No cracks are allowed and terminations shall be covered at least 60% with new solder.		Capacitance	<table border="1"> <tr> <th>Characteristics</th> <th>Change from the value before test</th> </tr> <tr> <td>C0G NPO</td> <td>±2.5%</td> </tr> </table>	Characteristics	Change from the value before test	C0G NPO	±2.5%		Q	Meet the initial spec.		Insulation Resistance	Meet the initial spec.		Voltage proof	No insulation breakdown or other damage.		Completely soak both terminations in solder at the following conditions. 260±5°C for 10±1s.  Preheating condition Temp.: 110 ~ 140°C Time : 30 ~ 60s.  Solder : Sn-3.0Ag-0.5Cu or Sn-37Pb  Flux : Isopropyl alcohol (JIS K 8839) Rosin (JIS K 5902) 25% solid solution.  Leave the capacitors in ambient condition for 6 to 24h before measurement.
External appearance	No cracks are allowed and terminations shall be covered at least 60% with new solder.																					
Capacitance	<table border="1"> <tr> <th>Characteristics</th> <th>Change from the value before test</th> </tr> <tr> <td>C0G NPO</td> <td>±2.5%</td> </tr> </table>	Characteristics	Change from the value before test	C0G NPO	±2.5%																	
Characteristics	Change from the value before test																					
C0G NPO	±2.5%																					
Q	Meet the initial spec.																					
Insulation Resistance	Meet the initial spec.																					
Voltage proof	No insulation breakdown or other damage.																					

(continued)

No.	Item	Performance	Test or inspection method															
11	Vibration	External appearance	Reflow solder the capacitors on a P.C.Board shown in Appendix 2 before testing.  Vibrate the capacitors with following conditions. Applied force : 5G max. Frequency : 10~2,000Hz Duration : 20 min. Cycle : 12 cycles in each 3 mutually perpendicular directions.															
		Capacitance		Characteristics	Change from the value before test													
				COG NPO	±2.5%													
		Q		Meet the initial spec.														
12	Temperature cycle	External appearance	Reflow Solder the capacitors on a P.C.Board shown in Appendix2 before testing.  Expose the capacitors in the condition step1 through 4 and repeat 1,000 times consecutively.  Leave the capacitors in ambient condition for 6 to 24h before measurement. <table border="1" data-bbox="1002 1088 1437 1368"> <thead> <tr> <th>Step</th> <th>Temperature(°C)</th> <th>Time(min.)</th> </tr> </thead> <tbody> <tr> <td>1</td> <td>Min. operating temp. ±3</td> <td>30 ± 3</td> </tr> <tr> <td>2</td> <td>Reference Temp.</td> <td>2 ~ 5</td> </tr> <tr> <td>3</td> <td>Max. operating temp. ±2</td> <td>30 ± 2</td> </tr> <tr> <td>4</td> <td>Reference Temp.</td> <td>2 ~ 5</td> </tr> </tbody> </table> As for Min./ Max. operating temp. and Reference temp., please refer to "3.OPERATING TEMPERATURE RANGE".	Step	Temperature(°C)	Time(min.)	1	Min. operating temp. ±3	30 ± 3	2	Reference Temp.	2 ~ 5	3	Max. operating temp. ±2	30 ± 2	4	Reference Temp.	2 ~ 5
		Step		Temperature(°C)	Time(min.)													
		1		Min. operating temp. ±3	30 ± 3													
		2		Reference Temp.	2 ~ 5													
		3		Max. operating temp. ±2	30 ± 2													
		4		Reference Temp.	2 ~ 5													
Capacitance	Characteristics	Change from the value before test																
	COG NPO	Please contact with our sales representative.																
Q	Meet the initial spec.																	
Insulation Resistance	Meet the initial spec.																	
Voltage proof	No insulation breakdown or other damage.																	
13	Moisture Resistance (Steady State)	External appearance	Reflow Solder the capacitors on a P.C.Board shown in Appendix2 before testing.  Leave at temperature 40±2°C, 90 to 95%RH for 500 +24,0h.  Leave the capacitors in ambient condition for 6 to 24h before measurement.															
		Capacitance		Characteristics	Change from the value before test													
				COG NPO	Please contact with our sales representative.													
		Q		350 min.														
Insulation Resistance	1,000MΩ min.																	

(continued)

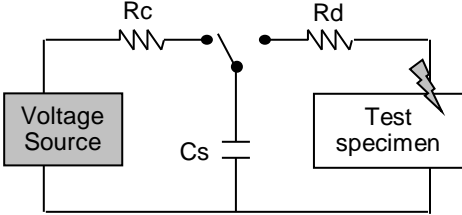
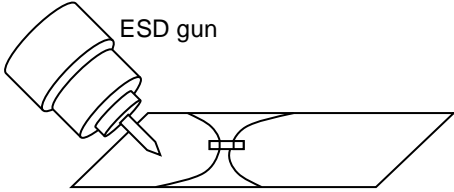
No.	Item	Performance	Test or inspection method					
14	Moisture Resistance	No mechanical damage.	Reflow Solder the capacitors on a P.C.Board shown in Appendix2 before testing.  Apply the rated voltage at temperature $85 \pm 2^{\circ}\text{C}$ and 85%RH for 1,000 +48,0h.  Charge/discharge current shall not exceed 50mA.  Leave the capacitors in ambient condition for 6 to 24h before measurement.					
	External appearance	Capacitance		<table border="1" style="width:100%; border-collapse: collapse;"> <tr> <td style="width:30%; text-align: center;">Characteristics</td> <td style="text-align: center;">Change from the value before test</td> </tr> <tr> <td style="text-align: center;">COG NP0</td> <td style="text-align: center;">Please contact with our sales representative.</td> </tr> </table>	Characteristics	Change from the value before test	COG NP0	Please contact with our sales representative.
		Characteristics		Change from the value before test				
	COG NP0	Please contact with our sales representative.						
Q	200 min.							
Insulation Resistance	500MΩ min.							
15	Life	No mechanical damage.	Reflow Solder the capacitors on a P.C.Board shown in Appendix2 before testing.  Test condition : Maximum operating temperature $\pm 2^{\circ}\text{C}$ for 1,000 +48,0h As for applied voltage, please contact with our sales representative.  Charge/discharge current shall not exceed 50mA.  Leave the capacitors in ambient condition for 6 to 24h before measurement.					
	External appearance	Capacitance		<table border="1" style="width:100%; border-collapse: collapse;"> <tr> <td style="width:30%; text-align: center;">Characteristics</td> <td style="text-align: center;">Change from the value before test</td> </tr> <tr> <td style="text-align: center;">COG NP0</td> <td style="text-align: center;">Please contact with our sales representative.</td> </tr> </table>	Characteristics	Change from the value before test	COG NP0	Please contact with our sales representative.
		Characteristics		Change from the value before test				
	COG NP0	Please contact with our sales representative.						
Q	350 min.							
Insulation Resistance	1,000MΩ min.							
16	ESD	Withstand ESD voltage without insulation breakdown.    Rc : Charge current limit resistor Rd : Discharge resistor Cs : Energy storage capacitor  	Reflow Solder the capacitors on a P.C.Board shown in Appendix3 before testing.  Circuit condition : IEC 61000-4-2 (Cs : 150pF / Rd : 330Ω) Test method : Direct contact Number of ESD pulse : $\pm 10$ times  As for applied ESD level, please refer to the table A in the end of the specification.  After each ESD pulse, dissipation of residual charge shall be done with applying 1MΩ resistance for 1 sec min.					



Appendix1

P.C.Board for bending test

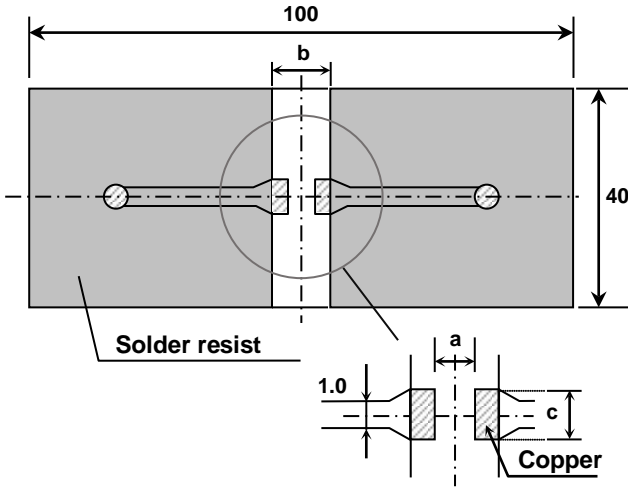

Appendix2

P.C. Board for reliability test

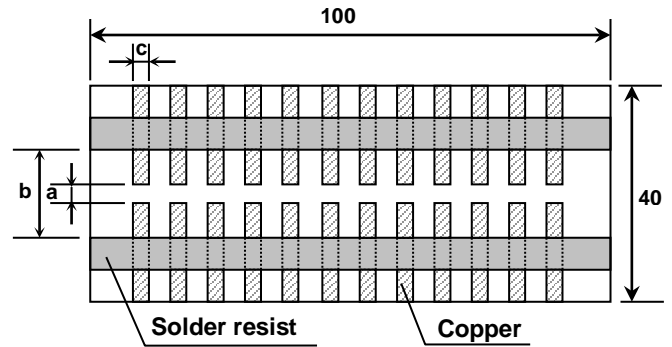

Appendix3

P.C. Board for ESD test

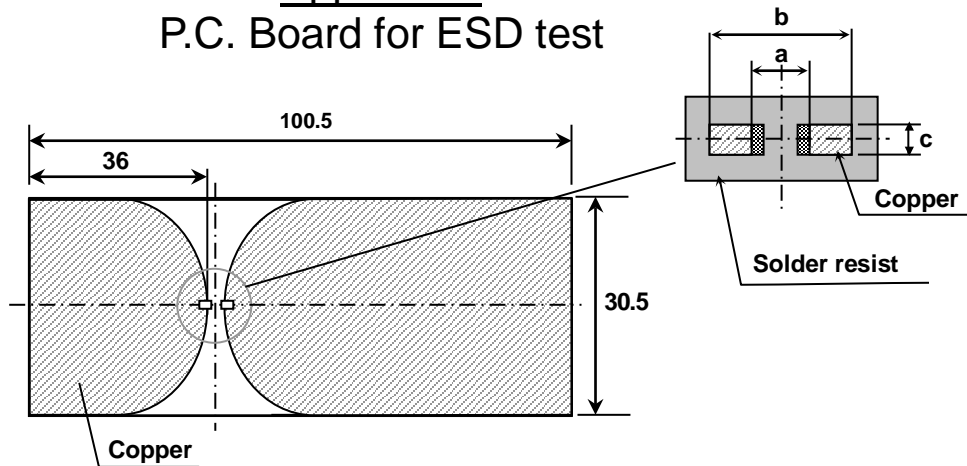

1. Material : Glass Epoxy  
(As per JIS C6484 GE4)

2. Thickness : 1.6mm

- Copper(Thickness:0.035mm)
- Solder resist

Appendix 1, 2 (Unit : mm)

Type	a	b	c
TDK(EIA style)			
CGA3(CC0603)	1.0	3.0	1.2

Appendix 3 (ESD TEST) (Unit : mm)

Type	a	b	c
TDK(EIA style)			
CGA3(CC0603)	1.0	3.0	0.75

## 7. INSIDE STRUCTURE AND MATERIAL

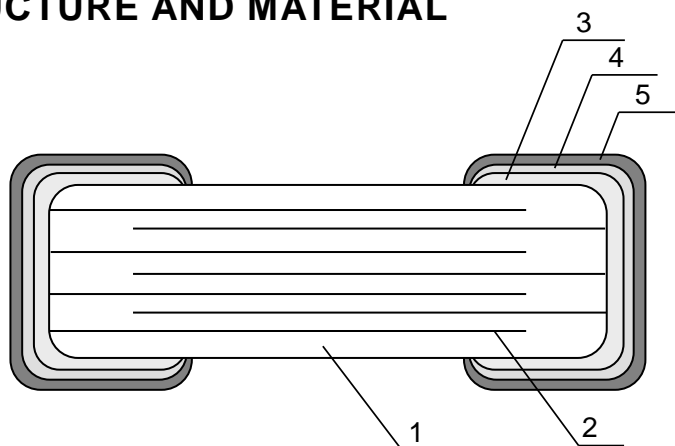

No.	NAME	MATERIAL
1	Dielectric	CaZrO <sub>3</sub>
2	Electrode	Nickel (Ni)
3	Termination	Copper (Cu)
4		Nickel (Ni)
5		Tin (Sn)

## 8. PACKAGING

Packaging shall be done to protect the components from the damage during transportation and storing, and a label which has the following information shall be attached.

- 1) Total number of components in a plastic bag for bulk packaging : 1000pcs
- 2) Tape packaging is as per 11. TAPE PACKAGING SPECIFICATION.

- 1) Inspection No.
- 2) TDK P/N
- 3) Customer's P/N
- 4) Quantity

\*Composition of Inspection No.

Example    F 8 A - 23 - 001  
                   (a) (b) (c)        (d)        (e)

- a) Line code
- b) Last digit of the year
- c) Month and A for January and B for February and so on. (Skip I)
- d) Inspection Date of the month.
- e) Serial No. of the day

\*Composition of new Inspection No.

(Will be implemented on and after Jan. 1, 2019)

Example    

I	F	9	A	23	A0	01
---	---	---	---	----	----	----

  
                   (a) (b) (c) (d)    (e)        (f)        (g)



- (a) Prefix
- (b) Line code
- (c) Last digit of the year
- (d) Month and A for January and B for February and so on. (Skip I)
- (e) Inspection Date of the month.
- (f) Serial No. of the day(00 ~ ZZ)
- (g) Suffix(00 ~ ZZ)

\* It is planned to shift to the new inspection No. on and after January 2019, but the implementation timing may be different depending on shipment bases.  
 Until the shift is completed, either current or new composition of inspection No. will be applied.

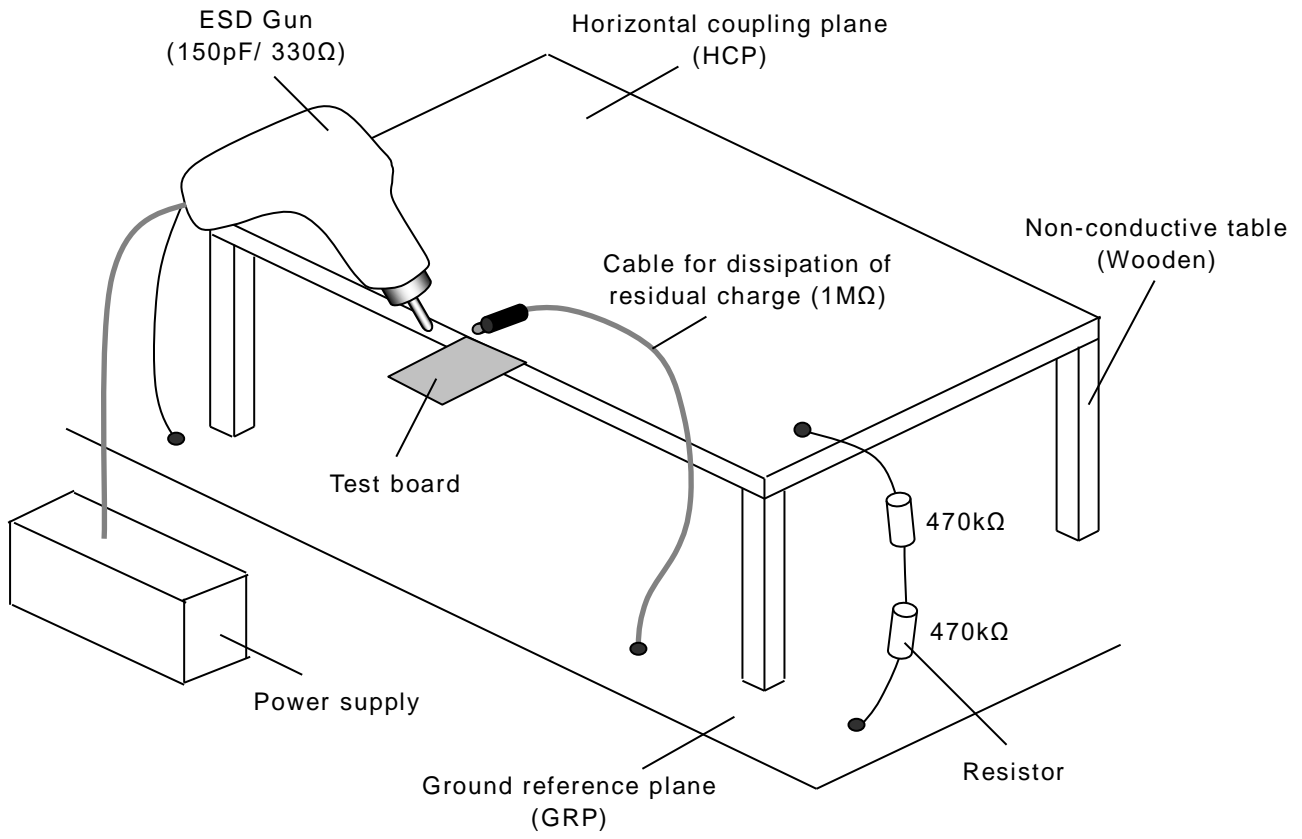
## 9. SETTING UP FOR ESD TEST

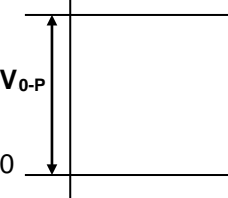
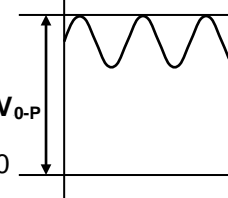
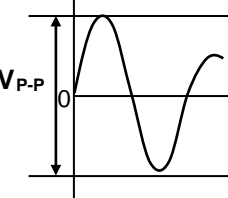
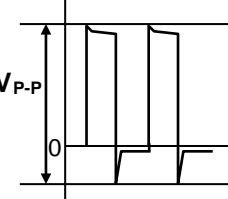
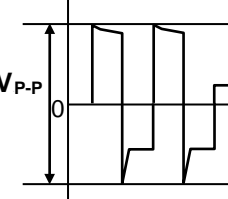
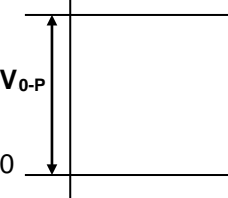
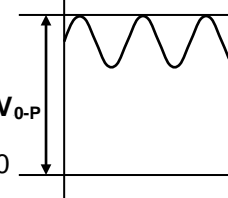
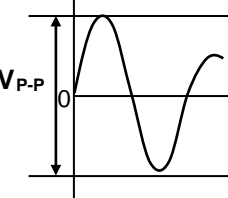
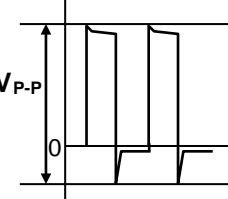
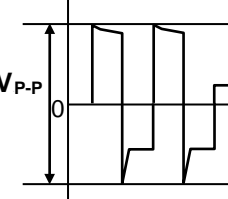
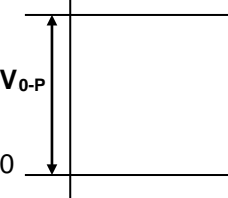
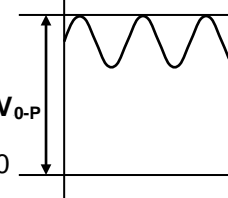
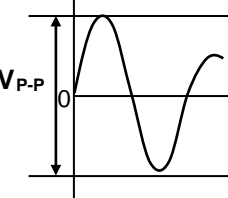
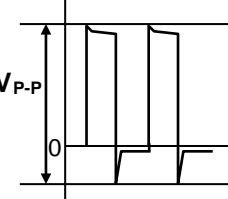
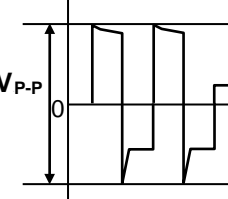

### 10. CAUTION

No.	Process	Condition														
1	Operating Condition (Storage, Use, Transportation)	<p>1-1. Storage, Use</p> <ol style="list-style-type: none"> <li>1) The capacitors must be stored in an ambient temperature of 5 to 40°C with a relative humidity of 20 to 70%RH. The products should be used within 6 months upon receipt.</li> <li>2) The capacitors must be operated and stored in an environment free of dew condensation and these gases such as Hydrogen Sulphide, Hydrogen Sulphate, Chlorine, Ammonia and sulfur.</li> <li>3) Avoid storing in sun light and falling of dew.</li> <li>4) Do not use capacitors under high humidity and high and low atmospheric pressure which may affect capacitors reliability.</li> <li>5) Capacitors should be tested for the solderability when they are stored for long time.</li> </ol> <p>1-2. Handling in transportation                      In case of the transportation of the capacitors, the performance of the capacitors may be deteriorated depending on the transportation condition.                      (Refer to JEITA RCR-2335C 9.2 Handling in transportation)</p>														
2	Circuit design  Caution	<p>2-1. Operating temperature                      Operating temperature should be followed strictly within this specification, especially be careful with maximum temperature.</p> <ol style="list-style-type: none"> <li>1) Do not use capacitors above the maximum allowable operating temperature.</li> <li>2) Surface temperature including self heating should be below maximum operating temperature.                      (Due to dielectric loss, capacitors will heat itself when AC is applied. Especially at high frequencies around its SRF, the heat might be so extreme that it may damage itself or the product mounted on. Please design the circuit so that the maximum temperature of the capacitors including the self heating to be below the maximum allowable operating temperature. Temperature rise at capacitor surface shall be below 20°C)</li> </ol> <p>The electrical characteristics of the capacitors will vary depending on the temperature. The capacitors should be selected and designed in taking the temperature into consideration.</p> <p>2-2. Operating voltage</p> <ol style="list-style-type: none"> <li>1) Operating voltage across the terminals should be below the rated voltage.                      When AC and DC are super imposed, <math>V_{0-P}</math> must be below the rated voltage.   (1) and (2)                      AC or pulse with overshooting, <math>V_{P-P}</math> must be below the rated voltage.   (3), (4) and (5)                      When the voltage is started to apply to the circuit or it is stopped applying, the irregular voltage may be generated for a transit period because of resonance or switching. Be sure to use the capacitors within rated voltage containing these Irregular voltage.</li> </ol> <table border="1" data-bbox="470 1518 1444 1787"> <thead> <tr> <th data-bbox="470 1518 662 1556">Voltage</th> <th data-bbox="662 1518 922 1556">(1) DC voltage</th> <th data-bbox="922 1518 1182 1556">(2) DC+AC voltage</th> <th data-bbox="1182 1518 1444 1556">(3) AC voltage</th> </tr> </thead> <tbody> <tr> <td data-bbox="470 1568 662 1787">Positional Measurement (Rated voltage)</td> <td data-bbox="662 1568 922 1787">  </td> <td data-bbox="922 1568 1182 1787">  </td> <td data-bbox="1182 1568 1444 1787">  </td> </tr> </tbody> </table> <table border="1" data-bbox="470 1809 1182 2078"> <thead> <tr> <th data-bbox="470 1809 662 1848">Voltage</th> <th data-bbox="662 1809 922 1848">(4) Pulse voltage (A)</th> <th data-bbox="922 1809 1182 1848">(5) Pulse voltage (B)</th> </tr> </thead> <tbody> <tr> <td data-bbox="470 1859 662 2078">Positional Measurement (Rated voltage)</td> <td data-bbox="662 1859 922 2078">  </td> <td data-bbox="922 1859 1182 2078">  </td> </tr> </tbody> </table>	Voltage	(1) DC voltage	(2) DC+AC voltage	(3) AC voltage	Positional Measurement (Rated voltage)				Voltage	(4) Pulse voltage (A)	(5) Pulse voltage (B)	Positional Measurement (Rated voltage)		
Voltage	(1) DC voltage	(2) DC+AC voltage	(3) AC voltage													
Positional Measurement (Rated voltage)																
Voltage	(4) Pulse voltage (A)	(5) Pulse voltage (B)														
Positional Measurement (Rated voltage)																

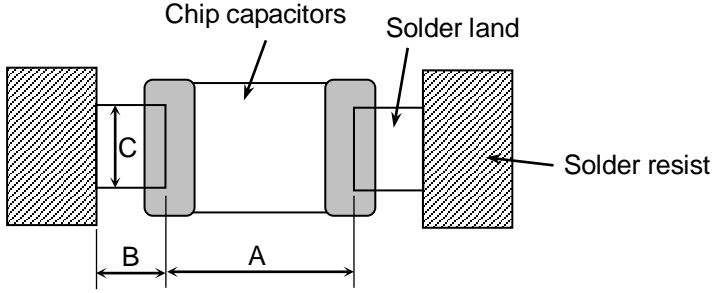
No.	Process	Condition																				
2	Circuit design  Caution	2) Even below the rated voltage, if repetitive high frequency AC or pulse is applied, the reliability of the capacitors may be reduced.  3) The effective capacitance will vary depending on applied DC and AC voltages. The capacitors should be selected and designed in taking the voltages into consideration.  2-3. Frequency When the capacitors (Class 2) are used in AC and/or pulse voltages, the capacitors may vibrate themselves and generate audible sound.																				
3	Designing P.C.board	<p>The amount of solder at the terminations has a direct effect on the reliability of the capacitors.</p> <ol style="list-style-type: none"> <li>1) The greater the amount of solder, the higher the stress on the chip capacitors, and the more likely that it will break. When designing a P.C.board, determine the shape and size of the solder lands to have proper amount of solder on the terminations.</li> <li>2) Avoid using common solder land for multiple terminations and provide individual solder land for each terminations.</li> <li>3) Size and recommended land dimensions.</li> </ol> <div style="text-align: center;">  </div> <table border="1" style="margin-left: auto; margin-right: auto;"> <thead> <tr> <th colspan="2" style="text-align: center;">Flow soldering(mm)</th> </tr> <tr> <th style="text-align: center;">Symbol \ Type</th> <th style="text-align: center;">CGA3 (CC0603)</th> </tr> </thead> <tbody> <tr> <td style="text-align: center;">A</td> <td style="text-align: center;">0.7 ~ 1.0</td> </tr> <tr> <td style="text-align: center;">B</td> <td style="text-align: center;">0.8 ~ 1.0</td> </tr> <tr> <td style="text-align: center;">C</td> <td style="text-align: center;">0.6 ~ 0.8</td> </tr> </tbody> </table> <table border="1" style="margin-left: auto; margin-right: auto;"> <thead> <tr> <th colspan="2" style="text-align: center;">Reflow soldering (mm)</th> </tr> <tr> <th style="text-align: center;">Symbol \ Type</th> <th style="text-align: center;">CGA3 (CC0603)</th> </tr> </thead> <tbody> <tr> <td style="text-align: center;">A</td> <td style="text-align: center;">0.6 ~ 0.8</td> </tr> <tr> <td style="text-align: center;">B</td> <td style="text-align: center;">0.6 ~ 0.8</td> </tr> <tr> <td style="text-align: center;">C</td> <td style="text-align: center;">0.6 ~ 0.8</td> </tr> </tbody> </table>	Flow soldering(mm)		Symbol \ Type	CGA3 (CC0603)	A	0.7 ~ 1.0	B	0.8 ~ 1.0	C	0.6 ~ 0.8	Reflow soldering (mm)		Symbol \ Type	CGA3 (CC0603)	A	0.6 ~ 0.8	B	0.6 ~ 0.8	C	0.6 ~ 0.8
Flow soldering(mm)																						
Symbol \ Type	CGA3 (CC0603)																					
A	0.7 ~ 1.0																					
B	0.8 ~ 1.0																					
C	0.6 ~ 0.8																					
Reflow soldering (mm)																						
Symbol \ Type	CGA3 (CC0603)																					
A	0.6 ~ 0.8																					
B	0.6 ~ 0.8																					
C	0.6 ~ 0.8																					

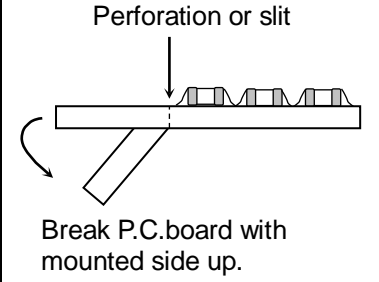
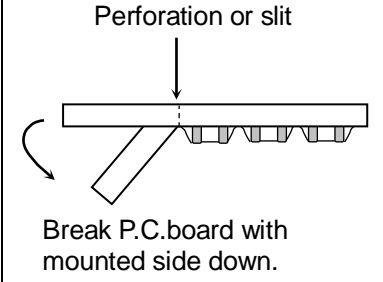
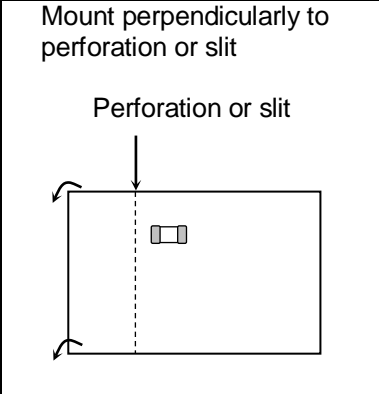
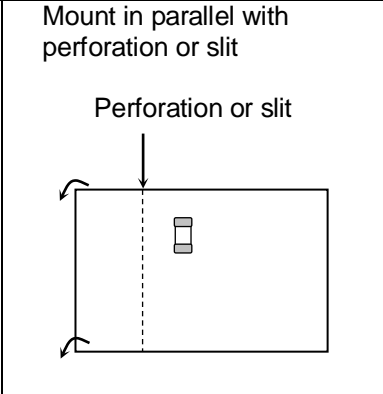
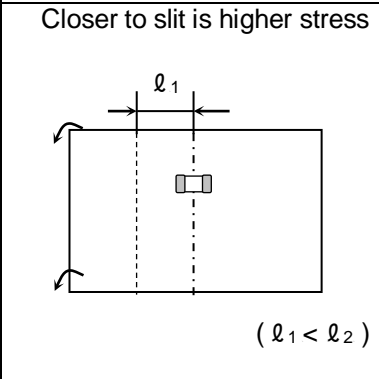
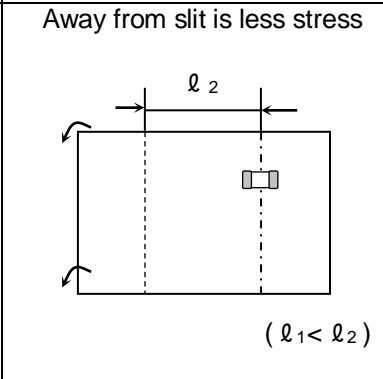
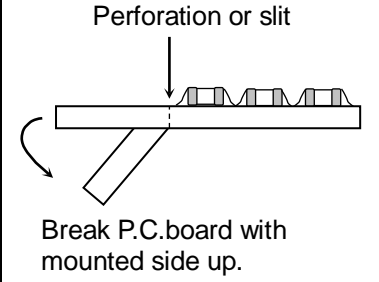
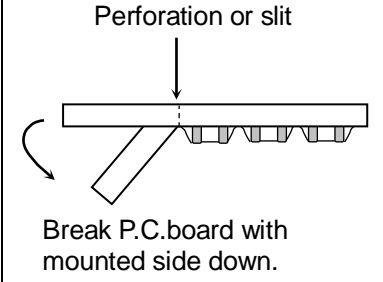
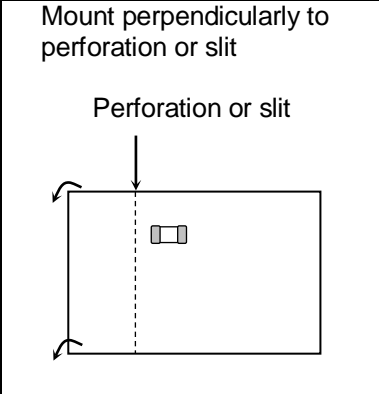
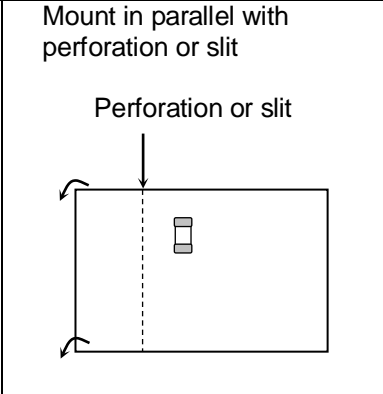
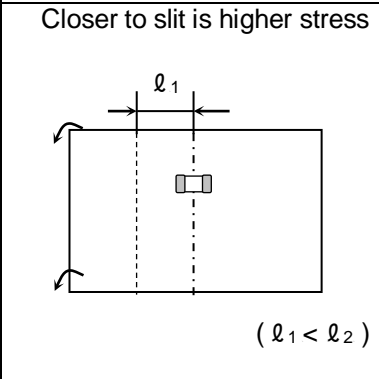
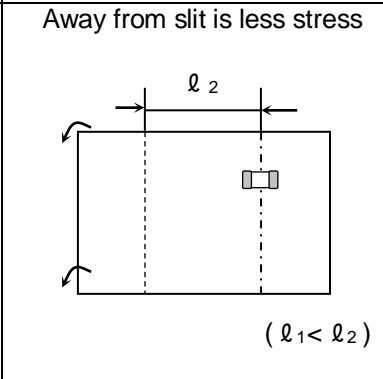
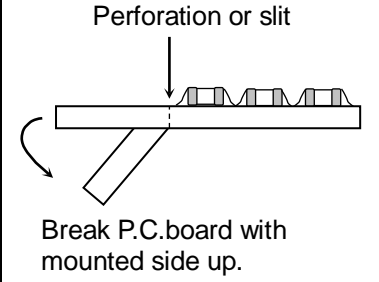
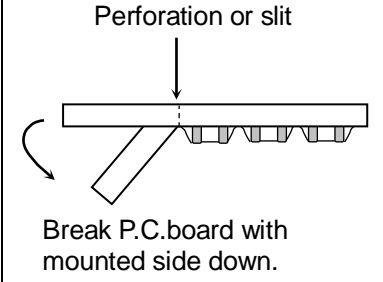
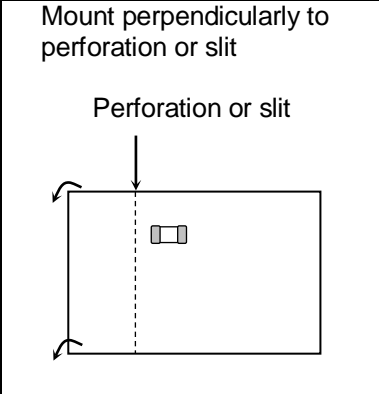
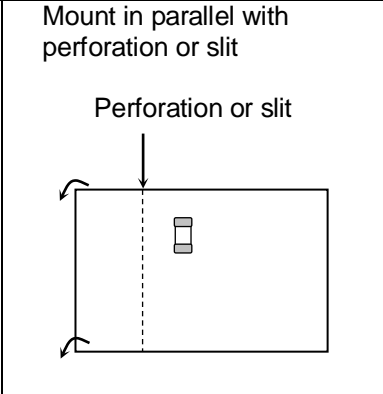
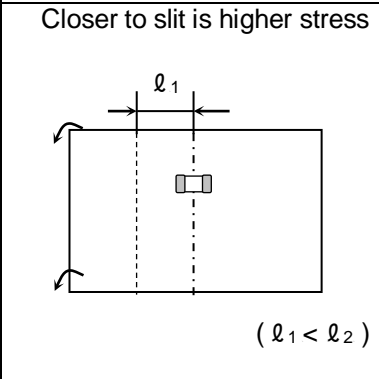
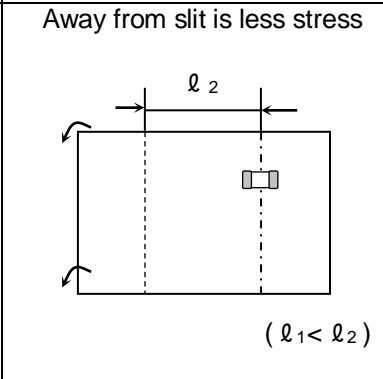
No.	Process	Condition												
3	Designing P.C.board	<p>4) Recommended chip capacitors layout is as following.</p> <table border="1" style="width: 100%; border-collapse: collapse;"> <thead> <tr> <th style="width: 20%;"></th> <th style="width: 40%;">Disadvantage against bending stress</th> <th style="width: 40%;">Advantage against bending stress</th> </tr> </thead> <tbody> <tr> <td style="text-align: center; vertical-align: middle;">Mounting face</td> <td style="text-align: center;"> <p>Perforation or slit</p>  <p>Break P.C.board with mounted side up.</p> </td> <td style="text-align: center;"> <p>Perforation or slit</p>  <p>Break P.C.board with mounted side down.</p> </td> </tr> <tr> <td style="text-align: center; vertical-align: middle;">Chip arrangement (Direction)</td> <td style="text-align: center;"> <p>Perforation or slit</p>  </td> <td style="text-align: center;"> <p>Perforation or slit</p>  </td> </tr> <tr> <td style="text-align: center; vertical-align: middle;">Distance from slit</td> <td style="text-align: center;"> <p>Closer to slit is higher stress</p>  <p><math>(l_1 &lt; l_2)</math></p> </td> <td style="text-align: center;"> <p>Away from slit is less stress</p>  <p><math>(l_1 &lt; l_2)</math></p> </td> </tr> </tbody> </table>		Disadvantage against bending stress	Advantage against bending stress	Mounting face	<p>Perforation or slit</p>  <p>Break P.C.board with mounted side up.</p>	<p>Perforation or slit</p>  <p>Break P.C.board with mounted side down.</p>	Chip arrangement (Direction)	<p>Perforation or slit</p> 	<p>Perforation or slit</p> 	Distance from slit	<p>Closer to slit is higher stress</p>  <p><math>(l_1 &lt; l_2)</math></p>	<p>Away from slit is less stress</p>  <p><math>(l_1 &lt; l_2)</math></p>
	Disadvantage against bending stress	Advantage against bending stress												
Mounting face	<p>Perforation or slit</p>  <p>Break P.C.board with mounted side up.</p>	<p>Perforation or slit</p>  <p>Break P.C.board with mounted side down.</p>												
Chip arrangement (Direction)	<p>Perforation or slit</p> 	<p>Perforation or slit</p> 												
Distance from slit	<p>Closer to slit is higher stress</p>  <p><math>(l_1 &lt; l_2)</math></p>	<p>Away from slit is less stress</p>  <p><math>(l_1 &lt; l_2)</math></p>												

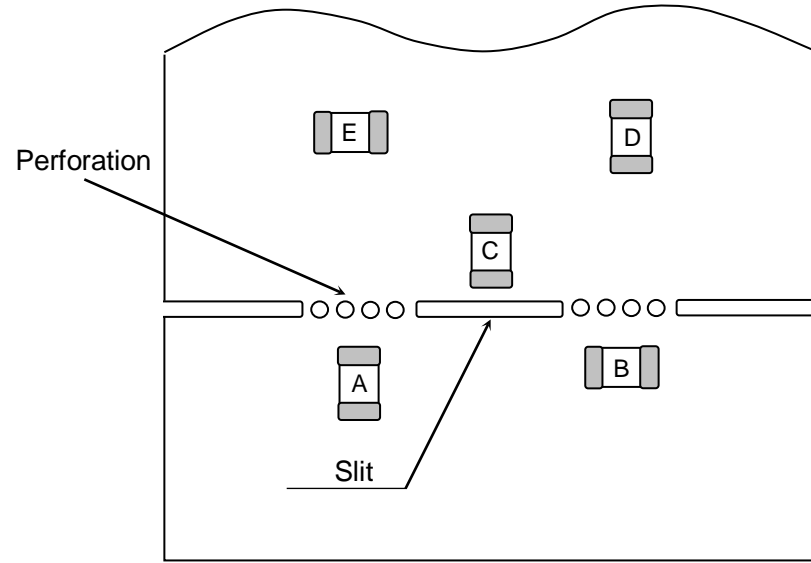
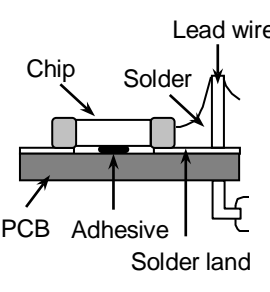
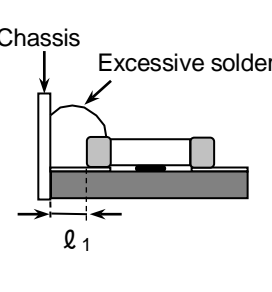
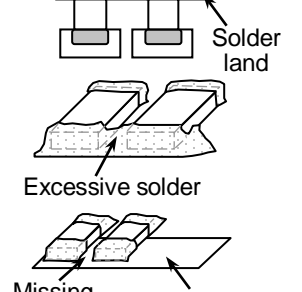
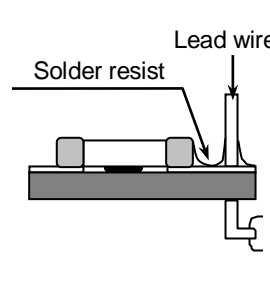
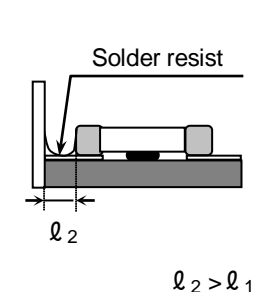
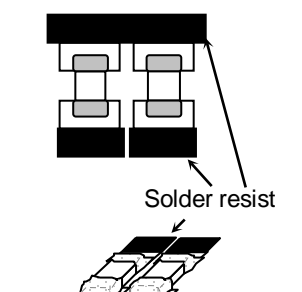
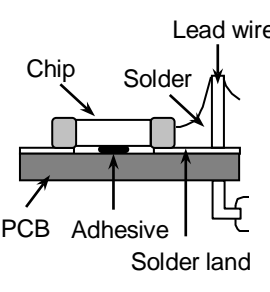
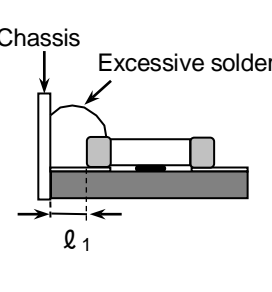
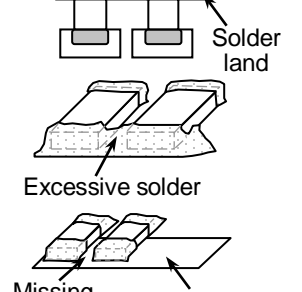
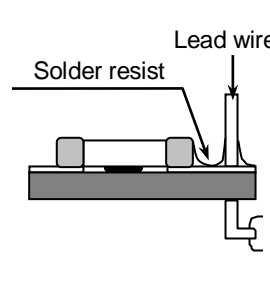
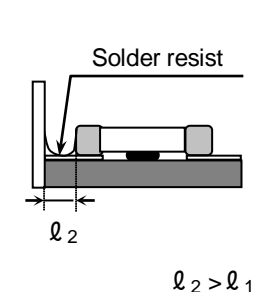
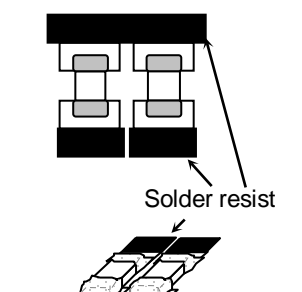
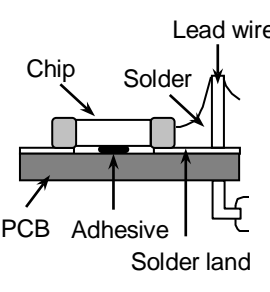
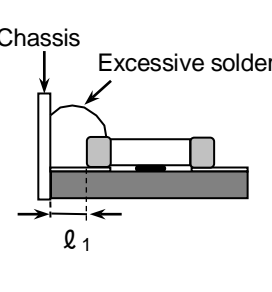
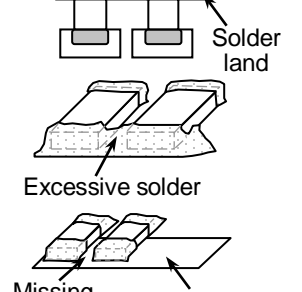
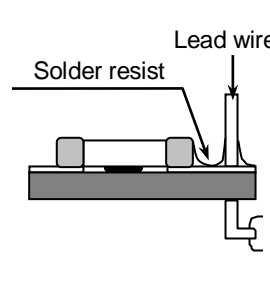
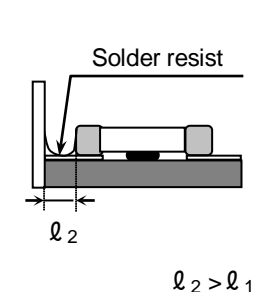
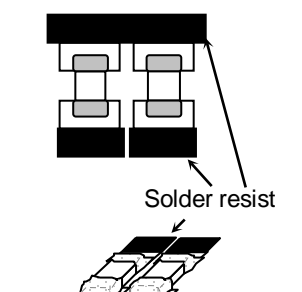
No.	Process	Condition												
3	Designing P.C.board	<p>5) Mechanical stress varies according to location of chip capacitors on the P.C.board.</p>  <p>The stress in capacitors is in the following order.  <math>A &gt; B = C &gt; D &gt; E</math></p> <p>6) Layout recommendation</p> <table border="1"> <thead> <tr> <th data-bbox="379 985 539 1097">Example</th> <th data-bbox="539 985 845 1097">Use of common solder land</th> <th data-bbox="845 985 1152 1097">Soldering with chassis</th> <th data-bbox="1152 985 1489 1097">Use of common solder land with other SMD</th> </tr> </thead> <tbody> <tr> <td data-bbox="379 1097 539 1478">Need to avoid</td> <td data-bbox="539 1097 845 1478">  </td> <td data-bbox="845 1097 1152 1478">  </td> <td data-bbox="1152 1097 1489 1478">  </td> </tr> <tr> <td data-bbox="379 1478 539 1881">Recommendation</td> <td data-bbox="539 1478 845 1881">  </td> <td data-bbox="845 1478 1152 1881">  </td> <td data-bbox="1152 1478 1489 1881">  </td> </tr> </tbody> </table>	Example	Use of common solder land	Soldering with chassis	Use of common solder land with other SMD	Need to avoid				Recommendation			
Example	Use of common solder land	Soldering with chassis	Use of common solder land with other SMD											
Need to avoid														
Recommendation														

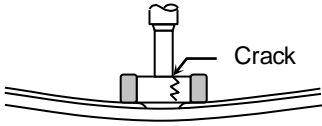
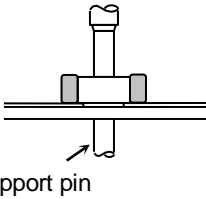
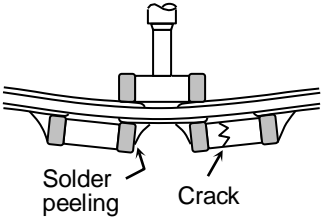
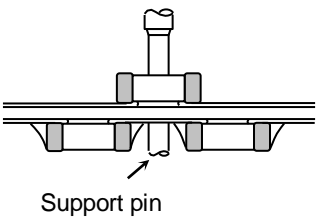
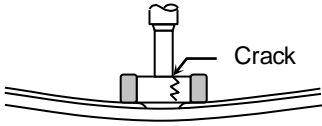
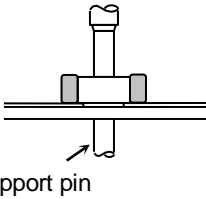
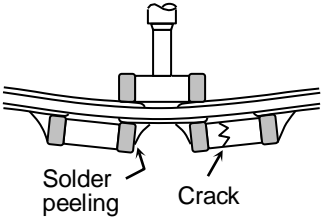
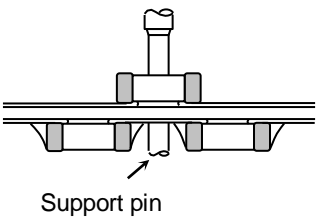
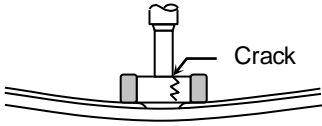
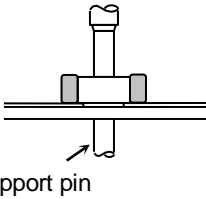
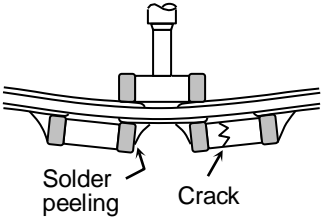
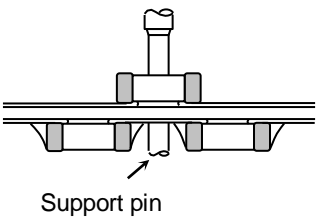
No.	Process	Condition									
4	Mounting	<p>4-1. Stress from mounting head                      If the mounting head is adjusted too low, it may induce excessive stress in the chip capacitors to result in cracking. Please take following precautions.</p> <ol style="list-style-type: none"> <li>1) Adjust the bottom dead center of the mounting head to reach on the P.C.board surface and not press it.</li> <li>2) Adjust the mounting head pressure to be 1 to 3N of static weight.</li> <li>3) To minimize the impact energy from mounting head, it is important to provide support from the bottom side of the P.C.board. See following examples.</li> </ol> <table border="1" data-bbox="481 566 1433 1133"> <thead> <tr> <th></th> <th data-bbox="667 566 1059 611">Not recommended</th> <th data-bbox="1059 566 1433 611">Recommended</th> </tr> </thead> <tbody> <tr> <td data-bbox="481 611 667 875">Single sided mounting</td> <td data-bbox="667 611 1059 875">  <p>Crack</p> </td> <td data-bbox="1059 611 1433 875">  <p>Support pin</p> </td> </tr> <tr> <td data-bbox="481 875 667 1133">Double-sides mounting</td> <td data-bbox="667 875 1059 1133">  <p>Solder peeling Crack</p> </td> <td data-bbox="1059 875 1433 1133">  <p>Support pin</p> </td> </tr> </tbody> </table> <p>When the centering jaw is worn out, it may give mechanical impact on the capacitors to cause crack. Please control the close up dimension of the centering jaw and provide sufficient preventive maintenance and replacement of it.</p>		Not recommended	Recommended	Single sided mounting	 <p>Crack</p>	 <p>Support pin</p>	Double-sides mounting	 <p>Solder peeling Crack</p>	 <p>Support pin</p>
	Not recommended	Recommended									
Single sided mounting	 <p>Crack</p>	 <p>Support pin</p>									
Double-sides mounting	 <p>Solder peeling Crack</p>	 <p>Support pin</p>									



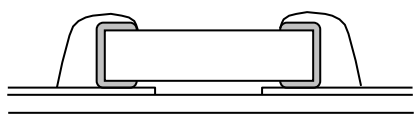
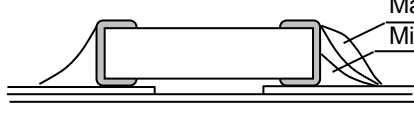
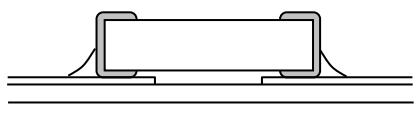

No.	Process	Condition																								
5	Soldering	<p>5-1. Flux selection</p> <p>Flux can seriously affect the performance of capacitors. Confirm the following to select the appropriate flux.</p> <ol style="list-style-type: none"> <li>1) It is recommended to use a mildly activated rosin flux (less than 0.1wt% chlorine). Strong flux is not recommended.</li> <li>2) Excessive flux must be avoided. Please provide proper amount of flux.</li> <li>3) When water-soluble flux is used, enough washing is necessary.</li> </ol> <p>5-2. Recommended soldering profile by various methods</p> <div style="display: flex; justify-content: space-around;"> <div style="text-align: center;"> <p><b>Wave soldering</b></p> </div> <div style="text-align: center;"> <p><b>Reflow soldering</b></p> </div> </div> <div style="text-align: center; margin-top: 20px;"> <p><b>Manual soldering (Solder iron)</b></p> </div> <p>※ As for peak temperature of manual soldering, please refer “5-6. Solder repair by solder iron” .</p> <p>5-3. Recommended soldering peak temp and peak temp duration</p> <table border="1" style="width: 100%; border-collapse: collapse;"> <thead> <tr> <th rowspan="2" style="text-align: center;">Temp./Duration</th> <th colspan="2" style="text-align: center;">Wave soldering</th> <th colspan="2" style="text-align: center;">Reflow soldering</th> </tr> <tr> <th style="text-align: center;">Peak temp(°C)</th> <th style="text-align: center;">Duration(sec.)</th> <th style="text-align: center;">Peak temp(°C)</th> <th style="text-align: center;">Duration(sec.)</th> </tr> </thead> <tbody> <tr> <td style="text-align: center;">Solder</td> <td></td> <td></td> <td></td> <td></td> </tr> <tr> <td style="text-align: center;">Sn-Pb Solder</td> <td style="text-align: center;">250 max.</td> <td style="text-align: center;">3 max.</td> <td style="text-align: center;">230 max.</td> <td style="text-align: center;">20 max.</td> </tr> <tr> <td style="text-align: center;">Lead Free Solder</td> <td style="text-align: center;">260 max.</td> <td style="text-align: center;">5 max.</td> <td style="text-align: center;">260 max.</td> <td style="text-align: center;">10 max.</td> </tr> </tbody> </table> <p>Recommended solder compositions                      Lead Free Solder : Sn-3.0Ag-0.5Cu                      Sn-Pb solder : Sn-37Pb</p>	Temp./Duration	Wave soldering		Reflow soldering		Peak temp(°C)	Duration(sec.)	Peak temp(°C)	Duration(sec.)	Solder					Sn-Pb Solder	250 max.	3 max.	230 max.	20 max.	Lead Free Solder	260 max.	5 max.	260 max.	10 max.
Temp./Duration	Wave soldering			Reflow soldering																						
	Peak temp(°C)	Duration(sec.)	Peak temp(°C)	Duration(sec.)																						
Solder																										
Sn-Pb Solder	250 max.	3 max.	230 max.	20 max.																						
Lead Free Solder	260 max.	5 max.	260 max.	10 max.																						

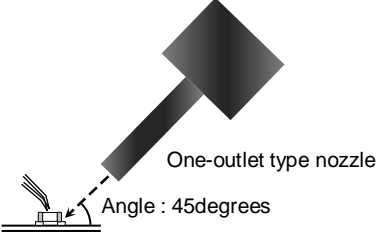
No.	Process	Condition																				
5	Soldering	<p>5-4. Avoiding thermal shock</p> <p>1) Preheating condition</p> <table border="1" data-bbox="539 280 1037 470"> <thead> <tr> <th>Soldering</th> <th>Temp. (°C)</th> </tr> </thead> <tbody> <tr> <td>Wave soldering</td> <td><math>\Delta T \leq 150</math></td> </tr> <tr> <td>Reflow soldering</td> <td><math>\Delta T \leq 150</math></td> </tr> <tr> <td>Manual soldering</td> <td><math>\Delta T \leq 150</math></td> </tr> </tbody> </table> <p>2) Cooling condition Natural cooling using air is recommended. If the chips are dipped into a solvent for cleaning, the temperature difference (<math>\Delta T</math>) must be less than 100°C.</p> <p>5-5. Amount of solder</p> <p>Excessive solder will induce higher tensile force in chip capacitors when temperature changes and it may result in chip cracking. In sufficient solder may detach the capacitors from the P.C.board.</p> <div style="display: flex; justify-content: space-between; align-items: flex-start;"> <div style="text-align: center;"> <p>Excessive solder</p>  </div> <div style="text-align: center;"> <p>Higher tensile force in chip capacitors to cause crack</p> </div> </div> <hr/> <div style="display: flex; justify-content: space-between; align-items: center;"> <div style="text-align: center;"> <p>Adequate</p>  </div> </div> <hr/> <div style="display: flex; justify-content: space-between; align-items: flex-start;"> <div style="text-align: center;"> <p>Insufficient solder</p>  </div> <div style="text-align: center;"> <p>Low robustness may cause contact failure or chip capacitors come off the P.C.board.</p> </div> </div> <hr/> <p>5-6. Solder repair by solder iron</p> <p>1) Selection of the soldering iron tip Tip temperature of solder iron varies by its type, P.C.board material and solder land size. The higher the tip temperature, the quicker the operation. However, heat shock may cause a crack in the chip capacitors. Please make sure the tip temp. before soldering and keep the peak temp and time in accordance with following recommended condition.</p> <table border="1" data-bbox="486 1512 1380 1624"> <thead> <tr> <th colspan="4">Recommended solder iron condition (Sn-Pb Solder and Lead Free Solder)</th> </tr> <tr> <th>Temp. (°C)</th> <th>Duration (sec.)</th> <th>Wattage (W)</th> <th>Shape (mm)</th> </tr> </thead> <tbody> <tr> <td>350 max.</td> <td>3 max.</td> <td>20 max.</td> <td>φ3.0 max.</td> </tr> </tbody> </table> <p>* Please preheat the chip capacitors with the condition in 5-4 to avoid the thermal shock.</p> <p>2) Direct contact of the soldering iron with ceramic dielectric of chip capacitors may cause crack. Do not touch the ceramic dielectric and the terminations by solder iron.</p>	Soldering	Temp. (°C)	Wave soldering	$\Delta T \leq 150$	Reflow soldering	$\Delta T \leq 150$	Manual soldering	$\Delta T \leq 150$	Recommended solder iron condition (Sn-Pb Solder and Lead Free Solder)				Temp. (°C)	Duration (sec.)	Wattage (W)	Shape (mm)	350 max.	3 max.	20 max.	φ3.0 max.
Soldering	Temp. (°C)																					
Wave soldering	$\Delta T \leq 150$																					
Reflow soldering	$\Delta T \leq 150$																					
Manual soldering	$\Delta T \leq 150$																					
Recommended solder iron condition (Sn-Pb Solder and Lead Free Solder)																						
Temp. (°C)	Duration (sec.)	Wattage (W)	Shape (mm)																			
350 max.	3 max.	20 max.	φ3.0 max.																			

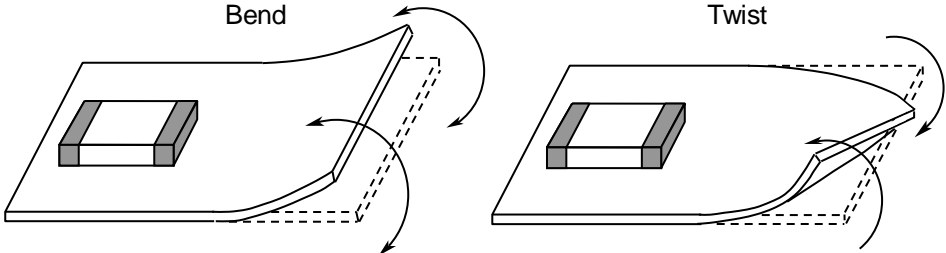
No.	Process	Condition												
5	Soldering	<p>5-7.Soldering rework using spot heater Heat stress during rework may possibly be reduced by using a spot heater (also called a “blower”) rather than a soldering iron. It is applied only to adding solder in the case of insufficient solder amount.</p> <p>1) Reworking using a spot heater may suppress the occurrence of cracks in the capacitor compared to using a soldering iron. A spot heater can heat up a capacitor uniformly with a small heat gradient which leads to lower thermal stress caused by quick heating and cooling or localized heating. Moreover, where ultra-small capacitors are mounted close together on a printed circuit board, reworking with a spot heater can eliminate the risk of direct contact between the tip of a soldering iron and a capacitor.</p> <p>2) Rework condition If the blower nozzle of a spot heater is too close to a capacitor, a crack in the capacitor may occur due to heat stress. Below are recommendations for avoiding such an occurrence. Keep more than 5mm between a capacitor and a spot heater nozzle. The blower temperature of the spot heater shall be lower than 400°C. The airflow shall be set as weak as possible. The diameter of the nozzle is recommended to be 2mm(one-outlet type).The size is standard and common. Duration of blowing hot air is recommended to be 10s or less, considering surface area of the capacitor and melting temperature of solder. The angle between the nozzle and the capacitor is recommended to be 45degrees in order to work easily and to avoid partial area heating. As is the case when using a soldering iron, preheating reduces thermal stress on capacitors and improves operating efficiency.</p> <ul style="list-style-type: none"> <li>Recommended rework condition (Consult the component manufactures for details.)</li> </ul> <table border="1" data-bbox="507 1137 1452 1467"> <tbody> <tr> <td>Distance from nozzle</td> <td>5mm and over</td> </tr> <tr> <td>Nozzle angle</td> <td>45degrees</td> </tr> <tr> <td>Nozzle temp.</td> <td>400°C and less</td> </tr> <tr> <td>Airflow</td> <td>Set as weak as possible (The airflow shall be the minimum value necessary for solder to melt in the conditions mentioned above.)</td> </tr> <tr> <td>Nozzle diameter</td> <td>φ2mm (one-outlet type)</td> </tr> <tr> <td>Blowing duration</td> <td>10s and less</td> </tr> </tbody> </table> <ul style="list-style-type: none"> <li>Example of recommended spot heater use</li> </ul>  <p>3) Amount of solder should be suitable to form a proper fillet shape. Excess solder causes mechanical and thermal stress on a capacitor and results in cracks. Insufficient solder causes weak adherence of the capacitor to the substrate and may result in detachment of a capacitor and deteriorate reliability of the printed wiring board. See the example of appropriate solder fillet shape for 5-5.Amount of solder.</p>	Distance from nozzle	5mm and over	Nozzle angle	45degrees	Nozzle temp.	400°C and less	Airflow	Set as weak as possible (The airflow shall be the minimum value necessary for solder to melt in the conditions mentioned above.)	Nozzle diameter	φ2mm (one-outlet type)	Blowing duration	10s and less
Distance from nozzle	5mm and over													
Nozzle angle	45degrees													
Nozzle temp.	400°C and less													
Airflow	Set as weak as possible (The airflow shall be the minimum value necessary for solder to melt in the conditions mentioned above.)													
Nozzle diameter	φ2mm (one-outlet type)													
Blowing duration	10s and less													

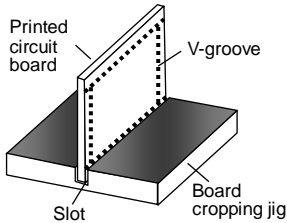
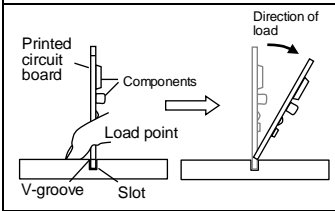
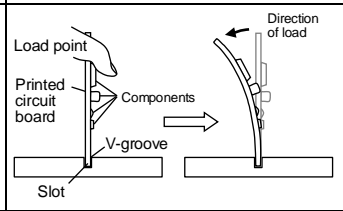
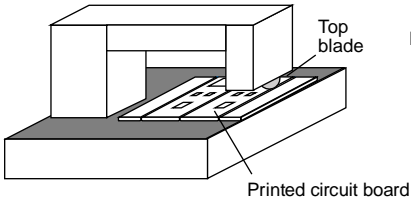
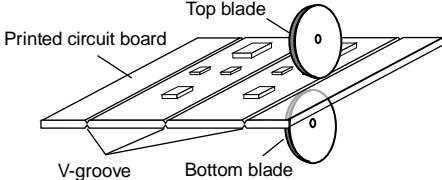
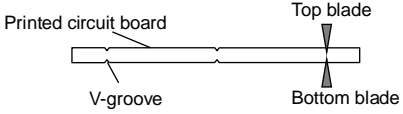
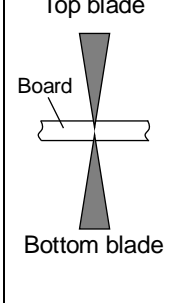
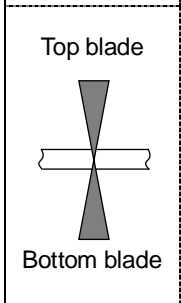
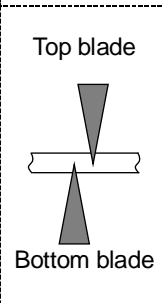
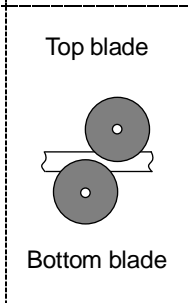
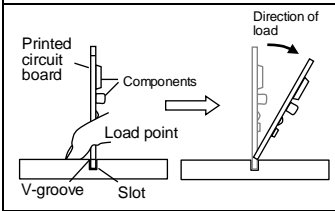
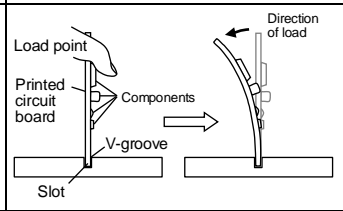
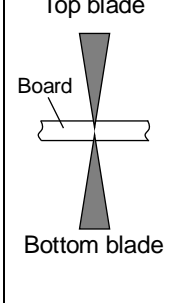
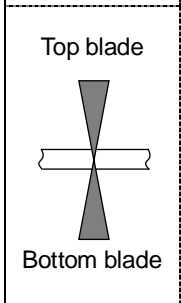
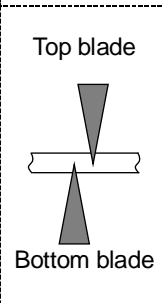
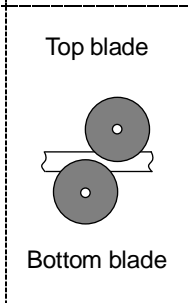
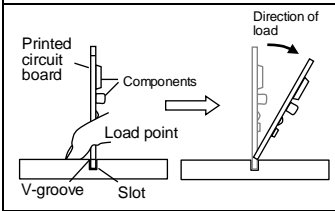
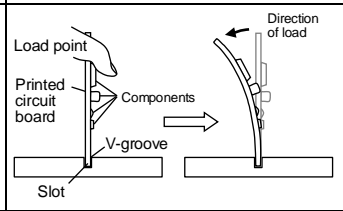
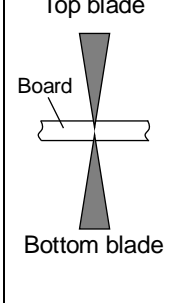
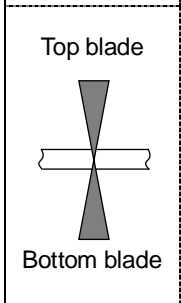
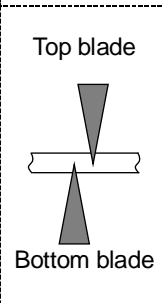
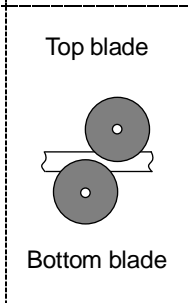
No.	Process	Condition
5	Soldering	<p>5-8. Sn-Zn solder Sn-Zn solder affects product reliability. Please contact TDK in advance when utilize Sn-Zn solder.</p> <p>5-9. Countermeasure for tombstone The misalignment between the mounted positions of the capacitors and the land patterns should be minimized. The tombstone phenomenon may occur especially the capacitors are mounted (in longitudinal direction) in the same direction of the reflow soldering. (Refer to JEITA RCR-2335C Annex A (Informative) Recommendations to prevent the tombstone phenomenon)</p>
6	Cleaning	<p>1) If an unsuitable cleaning fluid is used, flux residue or some foreign articles may stick to chip capacitors surface to deteriorate especially the insulation resistance.</p> <p>2) If cleaning condition is not suitable, it may damage the chip capacitors.</p> <p>2)-1. Insufficient washing (1) Terminal electrodes may corrode by Halogen in the flux. (2) Halogen in the flux may adhere on the surface of capacitors, and lower the insulation resistance. (3) Water soluble flux has higher tendency to have above mentioned problems (1) and (2).</p> <p>2)-2. Excessive washing When ultrasonic cleaning is used, excessively high ultrasonic energy output can affect the connection between the ceramic chip capacitor's body and the terminal electrode. To avoid this, following is the recommended condition.</p> <p style="text-align: center;">Power : 20W/ℓ max. Frequency : 40kHz max. Washing time : 5 minutes max.</p> <p>2)-3. If the cleaning fluid is contaminated, density of Halogen increases, and it may bring the same result as insufficient cleaning.</p>
7	Coating and molding of the P.C.board	<p>1) When the P.C.board is coated, please verify the quality influence on the product.</p> <p>2) Please verify carefully that there is no harmful decomposing or reaction gas emission during curing which may damage the chip capacitors.</p> <p>3) Please verify the curing temperature.</p>
8	Handling after chip mounted ⚠ Caution	<p>1) Please pay attention not to bend or distort the P.C.board after soldering in handling otherwise the chip capacitors may crack.</p> <div style="text-align: center;">  </div>

No.	Process	Condition																
8	Handling after chip mounted  Caution	<p>2) Printed circuit board cropping should not be carried out by hand, but by using the proper tooling. Printed circuit board cropping should be carried out using a board cropping jig as shown in the following figure or a board cropping apparatus to prevent inducing mechanical stress on the board.</p> <p>(1) Example of a board cropping jig                      Recommended example: The board should be pushed from the back side, close to the cropping jig so that the board is not bent and the stress applied to the capacitor is compressive.                      Unrecommended example: If the pushing point is far from the cropping jig and the pushing direction is from the front side of the board, large tensile stress is applied to the capacitor, which may cause cracks.</p> <div style="display: flex; justify-content: space-around;"> <div data-bbox="464 577 751 837"> <p>Outline of jig</p>  </div> <div data-bbox="762 568 1442 831"> <table border="1"> <thead> <tr> <th data-bbox="762 568 1098 622">Recommended</th> <th data-bbox="1098 568 1442 622">Unrecommended</th> </tr> </thead> <tbody> <tr> <td data-bbox="762 622 1098 831">  </td> <td data-bbox="1098 622 1442 831">  </td> </tr> </tbody> </table> </div> </div> <p>(2) Example of a board cropping machine                      An outline of a printed circuit board cropping machine is shown below. The top and bottom blades are aligned with one another along the lines with the V-grooves on printed circuit board when cropping the board.                      Unrecommended example: Misalignment of blade position between top and bottom, right and left, or front and rear blades may cause a crack in the capacitor.</p> <div style="display: flex; justify-content: space-around;"> <div data-bbox="555 1162 967 1424"> <p>Outline of machine</p>  </div> <div data-bbox="962 1162 1406 1406"> <p>Principle of operation</p>  </div> </div> <div style="display: flex; justify-content: center; margin-top: 10px;"> <p>Cross-section diagram</p>  </div> <table border="1" style="width: 100%; margin-top: 20px; text-align: center;"> <thead> <tr> <th data-bbox="641 1646 821 1731">Recommended</th> <th colspan="3" data-bbox="821 1646 1353 1697">Unrecommended</th> </tr> <tr> <th data-bbox="641 1731 821 1771"></th> <th data-bbox="821 1697 1002 1771">Top-bottom misalignment</th> <th data-bbox="1002 1697 1166 1771">Left-right misalignment</th> <th data-bbox="1166 1697 1353 1771">Front-rear misalignment</th> </tr> </thead> <tbody> <tr> <td data-bbox="641 1771 821 2072">  </td> <td data-bbox="821 1771 1002 2072">  </td> <td data-bbox="1002 1771 1166 2072">  </td> <td data-bbox="1166 1771 1353 2072">  </td> </tr> </tbody> </table>	Recommended	Unrecommended			Recommended	Unrecommended				Top-bottom misalignment	Left-right misalignment	Front-rear misalignment				
Recommended	Unrecommended																	
																		
Recommended	Unrecommended																	
	Top-bottom misalignment	Left-right misalignment	Front-rear misalignment															
																		

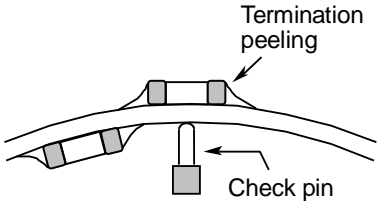
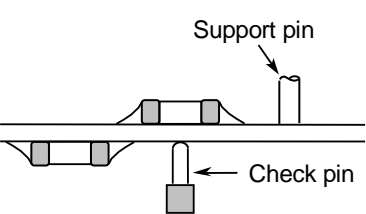
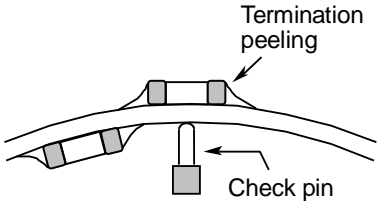
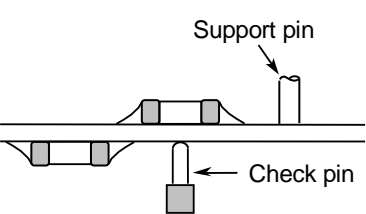
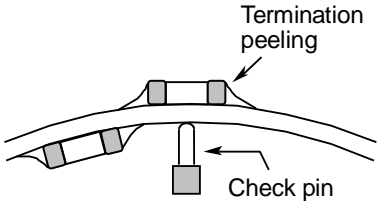
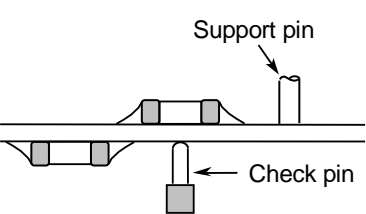
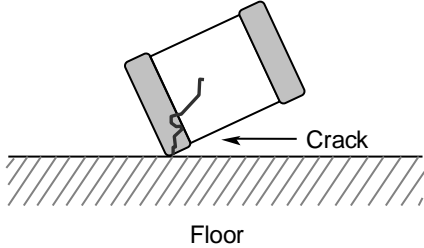
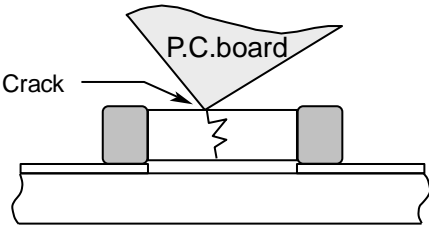
No.	Process	Condition						
8	Handling after chip mounted  Caution	<p>3) When functional check of the P.C.board is performed, check pin pressure tends to be adjusted higher for fear of loose contact. But if the pressure is excessive and bend the P.C.board, it may crack the chip capacitors or peel the terminations off. Please adjust the check pins not to bend the P.C.board.</p> <table border="1" data-bbox="475 383 1433 685"> <thead> <tr> <th data-bbox="475 383 616 443">Item</th> <th data-bbox="616 383 1034 443">Not recommended</th> <th data-bbox="1034 383 1433 443">Recommended</th> </tr> </thead> <tbody> <tr> <td data-bbox="475 443 616 685">Board bending</td> <td data-bbox="616 443 1034 685">  </td> <td data-bbox="1034 443 1433 685">  </td> </tr> </tbody> </table>	Item	Not recommended	Recommended	Board bending		
Item	Not recommended	Recommended						
Board bending								
9	Handling of loose chip capacitors	<p>1) If dropped the chip capacitors may crack. Once dropped do not use it. Especially, the large case sized chip capacitors are tendency to have cracks easily, so please handle with care.</p>  <p style="text-align: center;">Floor</p> <p>2) Piling the P.C.board after mounting for storage or handling, the corner of the P.C. board may hit the chip capacitors of another board to cause crack.</p> 						
10	Capacitance aging	The capacitors have aging in the capacitance. They may not be used in precision time constant circuit. In case of the time constant circuit, the evaluation should be done well.						
11	Estimated life and estimated failure rate of capacitors	As per the estimated life and the estimated failure rate depend on the temperature and the voltage. This can be calculated by the equation described in JEITA RCR-2335C Annex F (Informative) Calculation of the estimated lifetime and the estimated failure rate (Voltage acceleration coefficient : 3 multiplication rule, Temperature acceleration coefficient : 10°C rule) The failure rate can be decreased by reducing the temperature and the voltage but they will not be guaranteed.						

No.	Process	Condition
12	Caution during operation of equipment	<p>1) A capacitor shall not be touched directly with bare hands during operation in order to avoid electric shock. Electric energy held by the capacitor may be discharged through the human body when touched with a bare hand. Even when the equipment is off, a capacitor may stay charged. The capacitor should be handled after being completely discharged using a resistor.</p> <p>2) The terminals of a capacitor shall not be short-circuited by any accidental contact with a conductive object. A capacitor shall not be exposed to a conductive liquid such as an acid or alkali solution. A conductive object or liquid, such as acid and alkali, between the terminals may lead to the breakdown of a capacitor due to short circuit</p> <p>3) Confirm that the environment to which the equipment will be exposed during transportation and operation meets the specified conditions. Do not to use the equipment in the following environments.</p> <p>(1) Environment where a capacitor is splattered with water or oil (2) Environment where a capacitor is exposed to direct sunlight (3) Environment where a capacitor is exposed to Ozone, ultraviolet rays or radiation (4) Environment where a capacitor exposed to corrosive gas(e.g. hydrogen sulfide, sulfur dioxide, chlorine. ammonia gas etc.) (5) Environment where a capacitor exposed to vibration or mechanical shock exceeding the specified limits. (6) Atmosphere change with causes condensation</p>
13	Others  Caution	<p>The product listed in this specification is intended for use in automotive applications under-normal operation and usage conditions.</p> <p>The product is not designed or warranted to meet the requirements of application listed below, whose performance and/or quality requires a more stringent level of safety or reliability, or whose failure, malfunction or defect could cause serious damage to society, person or property. Please understand that we are not responsible for any damage or liability caused by use of the products in any of the applications below or for any other use exceeding the range or conditions set forth in this specification sheet. If you intend to use the products in the applications listed below or if you have special requirements exceeding the range or conditions set forth in this specification, please contact us.</p> <p>(1) Aerospace/Aviation equipment (2) Transportation equipment (electric trains, ships etc.) (3) Medical equipment (Excepting Pharmaceutical Affairs Law classification Class1, 2) (4) Power-generation control equipment (5) Atomic energy-related equipment (6) Seabed equipment (7) Transportation control equipment (8) Public information-processing equipment (9) Military equipment (10) Electric heating apparatus, burning equipment (11) Disaster prevention/crime prevention equipment (12) Safety equipment (13) Other applications that are not considered general-purpose applications</p> <p>When designing your equipment even for general-purpose applications, you are kindly requested to take into consideration securing protection circuit/device or providing backup circuits in your equipment.</p> <p>In addition, although the products listed in this specification is intended for use in automotive application as described above, it is not prohibited to use for general electronic equipment, whose performance and/or quality doesn't require a more stringent level of safety or reliability, or whose failure, malfunction or defect could not cause serious damage to society, person or property. Therefore, the description of this caution will be applied, when the products are used in general electronic equipment under a normal operation and usage conditions.</p>

## 11. TAPE PACKAGING SPECIFICATION

### 1. CONSTRUCTION AND DIMENSION OF TAPING

#### 1-1. Dimensions of carrier tape

Dimensions of paper tape shall be according to Appendix 4.

#### 1-2. Bulk part and leader of taping

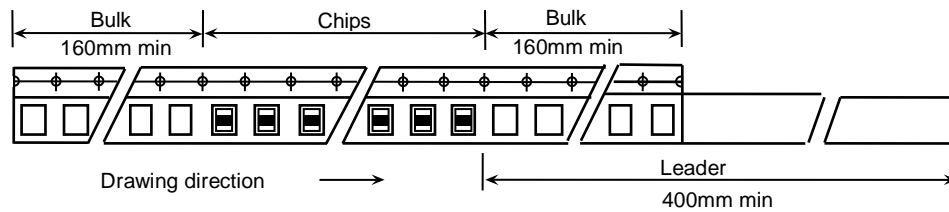

#### 1-3. Dimensions of reel

Dimensions of  $\phi 178$  reel shall be according to Appendix 5.

Dimensions of  $\phi 330$  reel shall be according to Appendix 6.

#### 1-4. Structure of taping

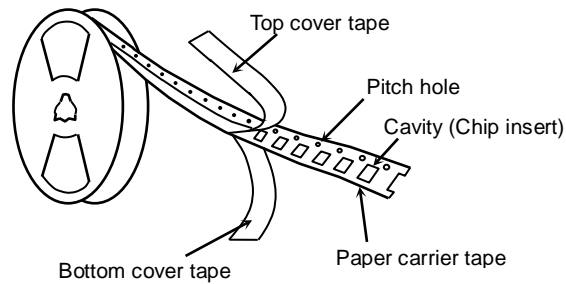

## 2. CHIP QUANTITY

Please refer to detail page on TDK Web.



### 3. PERFORMANCE SPECIFICATIONS

#### 3-1. Fixing peeling strength (top tape)

$$0.05\text{N} < \text{Peeling strength} < 0.7\text{N}$$

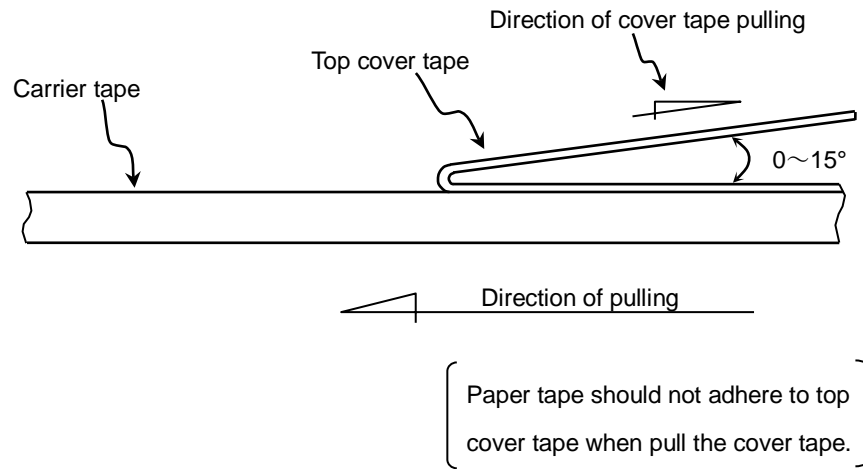

3-2. Carrier tape shall be flexible enough to be wound around a minimum radius of 30mm with components in tape.

3-3. The missing of components shall be less than 0.1%

3-4. Components shall not stick to fixing tape.

3-5. When removing the cover tape, there shall not be difficulties by unfitting clearance gap, burrs and crushes of cavities. Also the sprocket holes shall not be covered by absorbing dust into the suction nozzle.

## Appendix 4

### Paper Tape

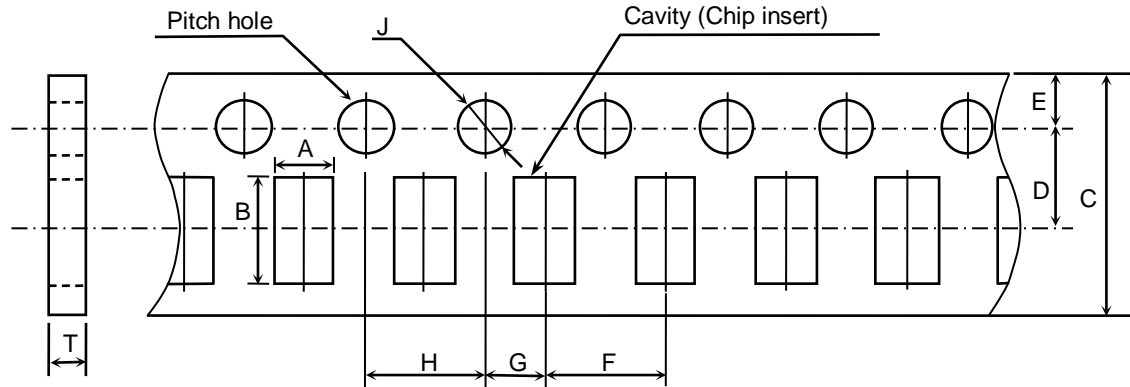

(Unit : mm)

Symbol Type	A	B	C	D	E	F
CGA3 (CC0603)	( 1.10 )	( 1.90 )	8.00 ± 0.30	3.50 ± 0.05	1.75 ± 0.10	4.00 ± 0.10

Symbol Type	G	H	J	T
CGA3 (CC0603)	2.00 ± 0.05	4.00 ± 0.10	$\phi 1.5 \begin{matrix} +0.1 \\ 0 \end{matrix}$	1.20 max.

( ) Reference value.

### Appendix 5

Dimensions of reel (Material : Polystyrene)

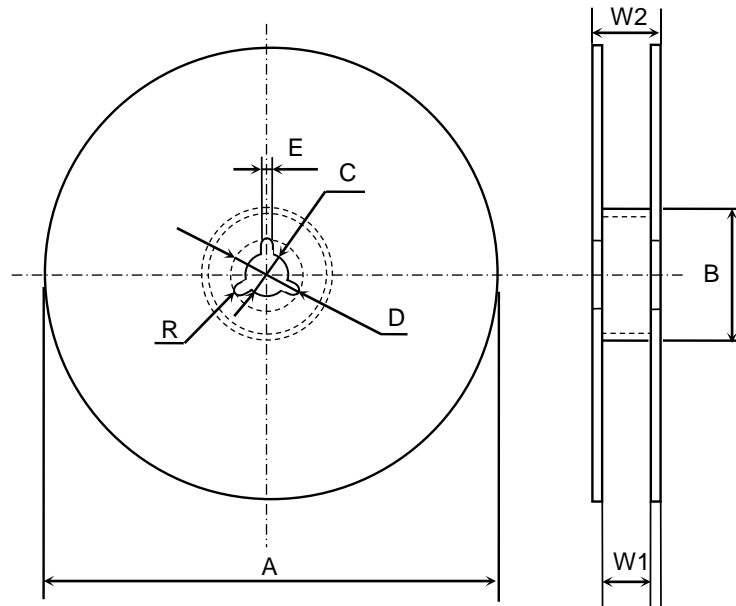

(Unit : mm)

Symbol	A	B	C	D	E	W1
Dimension	$\phi 178 \pm 2.0$	$\phi 60 \pm 2.0$	$\phi 13 \pm 0.5$	$\phi 21 \pm 0.8$	$2.0 \pm 0.5$	$9.0 \pm 0.3$
Symbol	W2	R				
Dimension	$13.0 \pm 1.4$	1.0				

### Appendix 6

Dimensions of reel (Material : Polystyrene)

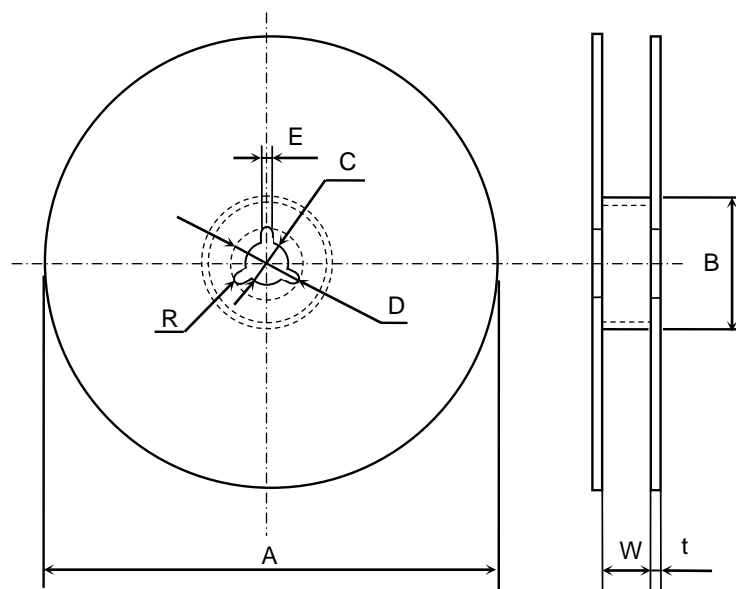

(Unit : mm)

Symbol	A	B	C	D	E	W
Dimension	$\phi 382$ max. (Nominal $\phi 330$ )	$\phi 50$ min.	$\phi 13 \pm 0.5$	$\phi 21 \pm 0.8$	$2.0 \pm 0.5$	$10.0 \pm 1.5$
Symbol	t	R				
Dimension	$2.0 \pm 0.5$	1.0				