

NOTES

- A : MODEL NAME, INPUT VOLTAGE RANGE, NOMINAL OUTPUT VOLTAGE, MAXIMUM OUTPUT CURRENT ARE SHOWN HERE IN ACCORDANCE WITH THE SPECIFICATIONS.
- B : COUNTRY OF MANUFACTURE IS SHOWN HERE.
- C : M4 TAPPED HOLES (16) FOR CUSTOMER CHASSIS MOUNTING. (SCREWS MUST NOT PROTRUDE INTO POWER SUPPLY BY MORE THAN 6m/m. RECOMMENDED M4 SCREWS TORQUE : 1.27N·m)
- D : I/O SIGNAL CONNECTOR
 CONNECTOR : S12B-PHDSS(LF)(SN) (JST)
 MATCHING HOUSING : PHDR-12VS (JST)
 MATCHING CONTACT : SPHD-002T-P0.5(AWG28~24) (JST) OR SPHD-001T-P0.5(AWG26~22) (JST) OR BPHD-001T-P0.5(AWG26~22) (JST)
 HAND CRIMPING TOOL : YRS-620(SPHD-002T-P0.5) (JST) YC-610R(SPHD-001T-P0.5) (JST) YC-610R(BPHD-001T-P0.5) (JST)
- E : RECOMMENDED TORQUE FOR THE TERMINAL PIECE.
 INPUT TERMINAL (M4 SCREW) : 1.27N·m
 OUTPUT TERMINAL (M8 BOLT & NUT) : 10.8N·m
 OUTPUT TERMINAL (M4 SCREW) : 1.27N·m

SIGNAL CONNECTOR INFORMATION

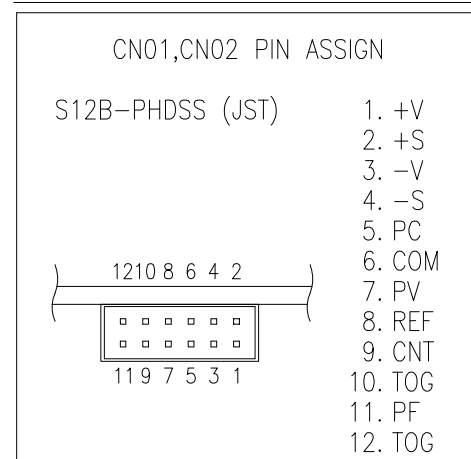

ACCESSORIES

- * ATTACHED CONNECTOR
- SHORTING +S~+V, -S~-V, PV~REF & CNT~TOG
- ATTACHED ON CN02 AT SHIPMENT

(unit : mm)

MODEL NAME	HWS1000/ME
DENSEI-LAMBDA	
DA032-02-01/ME	