



PFH

PMBus Specification & Application note

Version 3.9

Customer Release

Table of Contents

PFH PMBus Commands.....	4
Data Format	6
Five Bit Two’s Complement Table:.....	6
PMBus Address Selection.....	7
Detailed Descriptions of the Supported PMBus Commands	9
Vout_Mode:	9
Vout_Command:.....	9
Vout_Droop:	9
Vout_OV_Fault_Limit:.....	10
OT_Fault_limit:.....	10
I_Out_OC_Fault Limit:.....	10
Vout_UV_Fault_Limit:.....	11
Read_Temperature_1:	11
Read_Temperature_2:	11
Read_Temperature_3:	11
Read_Temperature_4:	12
Read_Vcap:	12
Read_Vout:	12
Read_Iout:.....	12
Read_Frequency:	13
Read_Vin:.....	13
Read_Iin:	13
Status_Word:	14
Status_Mfr_Specific:	14
SMBAlert_Mask:	15
Operation:.....	15
Read_MFR_ID:	16
Read_MFR_MODEL:.....	16
Read_MFR_REVISION:	16
Read_MFR_LOCATION:	16
Read_MFR_DATE:	17

TDK-Lambda Americas Inc.	2020
Read_MFR_SUPPORT:.....	17
PMBus_Revision:.....	17
PMBus Reserved Commands:	17
Save User Data:	18
Restore User Data:.....	18
Restore Manufactures Data:.....	18
PMBUS Timing:.....	19
PFH Sequence Timing:.....	20
PFH Startup/Shutdown Timing:	21

PFH PMBus Commands					
Hex Code	Command Name	Data Type	Data Byte	Data Format	n
Output Commands					
01	OPERATION	Write Byte	1	---	---
20	VOUT_MODE	Read Byte	1	---	---
21	VOUT_COMMAND	Read/Write Word	2	Linear 11/16	-5
28	VOUT_DROOP	Read Word	2	Linear 11	0
Alarm Commands					
40	VOUT_OV_FAULT_LIMIT	Read/Write Word	2	Linear 11	-5
44	VOUT_UV_FAULT_LIMIT	Read/Write Word	2	Linear 11	-5
46	IOUT_OC_FAULT_LIMIT	Read/Write Word	2	Linear 11	-5
4F	OT_FAULT_LIMIT	Read/Write Word	2	Linear 11	-3
Status Commands					
1B	SMBALERT_MASK	Read/Write Word	2	---	---
79	STATUS_WORD	Read Word	2	---	---
80	STATUS_MFR_SPECIFIC	Read Word	2	---	---
Monitoring Commands					
88	READ_Vin	Read Word	2	Linear 11	1
89	READ_Iin	Read Word	2	Linear 11	-5
8A	READ_VCAP	Read Word	2	Linear 11	-2
8B	READ_VOUT	Read Word	2	Linear 11	-5
8C	READ_IOUT	Read Word	2	Linear 11	-5
8D	READ_TEMPERATURE_1	Read Word	2	Linear 11	-3
8E	READ_TEMPERATURE_2	Read Word	2	Linear 11	-3
8F	READ_TEMPERATURE_3	Read Word	2	Linear 11	-3
DF	READ_TEMPERATURE_4	Read Word	2	Linear 11	-3
95	READ_FREQUENCY	Read Word	2	Linear 11	-3
98	PMBUS_REVISION	Read Byte	1	---	---
Manufacturing Commands					
99	MFR_ID	Read Block	---	---	---
9A	MFR_MODEL	Read Block	---	---	---
9B	MFR_REVISION	Read Block	---	---	---
9C	MFR_LOCATION	Read Block	---	---	---
9D	MFR_DATE	Read Block	---	---	---
9F	MFR_SUPPORT	Read Block	---	---	---
System Commands					
14	RESTORE_MANUFACTURES_DATA	Read Word	2	Linear 11	-5
15	SAVE_USER_DATA	Write Byte	1	---	---
16	RESTORE_USER_DATA	Read Word	2	Linear 11	-5

Reserved Commands					
D9	Reserved	---	---	---	---
F0	Reserved	---	---	---	---
E7	Reserved	---	---	---	---
FD	Reserved	---	---	---	---
9E	Reserved	---	---	---	---
B0	Reserved	---	---	---	---
B1	Reserved	---	---	---	---
B2	Reserved	---	---	---	---
B3	Reserved	---	---	---	---
B4	Reserved	---	---	---	---
D5	Reserved	---	---	---	---
D6	Reserved	---	---	---	---
D8	Reserved	---	---	---	---
D7	Reserved	---	---	---	---
23	Reserved	---	---	---	---
39	Reserved	---	---	---	---
BC	Reserved	---	---	---	---
BD	Reserved	---	---	---	---
BE	Reserved	---	---	---	---
BF	Reserved	---	---	---	---
B5	Reserved	---	---	---	---
B6	Reserved	---	---	---	---

Data Format

Linear 11 Data Format

The linear data format is a two byte value with a two's complement exponent and an 11-bit Mantissa. As shown below

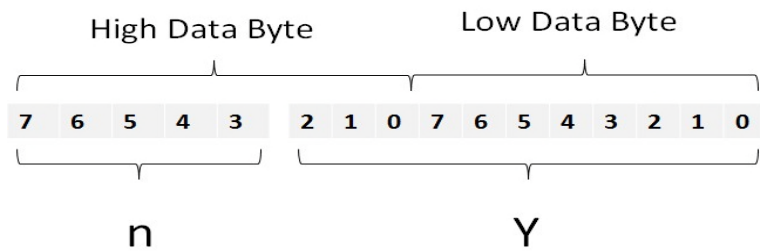

The Actual Value is given by the following equation:

$$\text{Actual Value} = Y \times 2^n$$

Example: Reading Vout returns 0xDB80

Breaking down the returned word into n & Y values

0xDB80 = 1101101110000000 binary

The first 5 bits represent n = 11011 = -5 decimal

The last 11 bits represent Y = 01110000000 = 0x380 = 896 decimal

Using the above equation:

$$V_{out} = 896 \times 2^{-5} = 28.0V$$

Five Bit Two's Complement Table:

Five-Bit Two's Complement Values		
Decimal Number	Two's Complement	two's complement exponent extraction
-8	11000	0xC000
-7	11001	0xC800
-6	11010	0xD000
-5	11011	0xD800
-4	11100	0xE000
-3	11101	0xE800
-2	11110	0xF000
-1	11111	0xF800
0	00000	0x0000
1	00001	0x0800
2	00010	0x1000
3	00011	0x1800
4	00100	0x2000
5	00101	0x2800

PMBus Address Selection

PMBus uses a 7-bit device address to identify the different devices on the bus.
 The address for the PFH converter is set using external resistors connected to the AD pins.

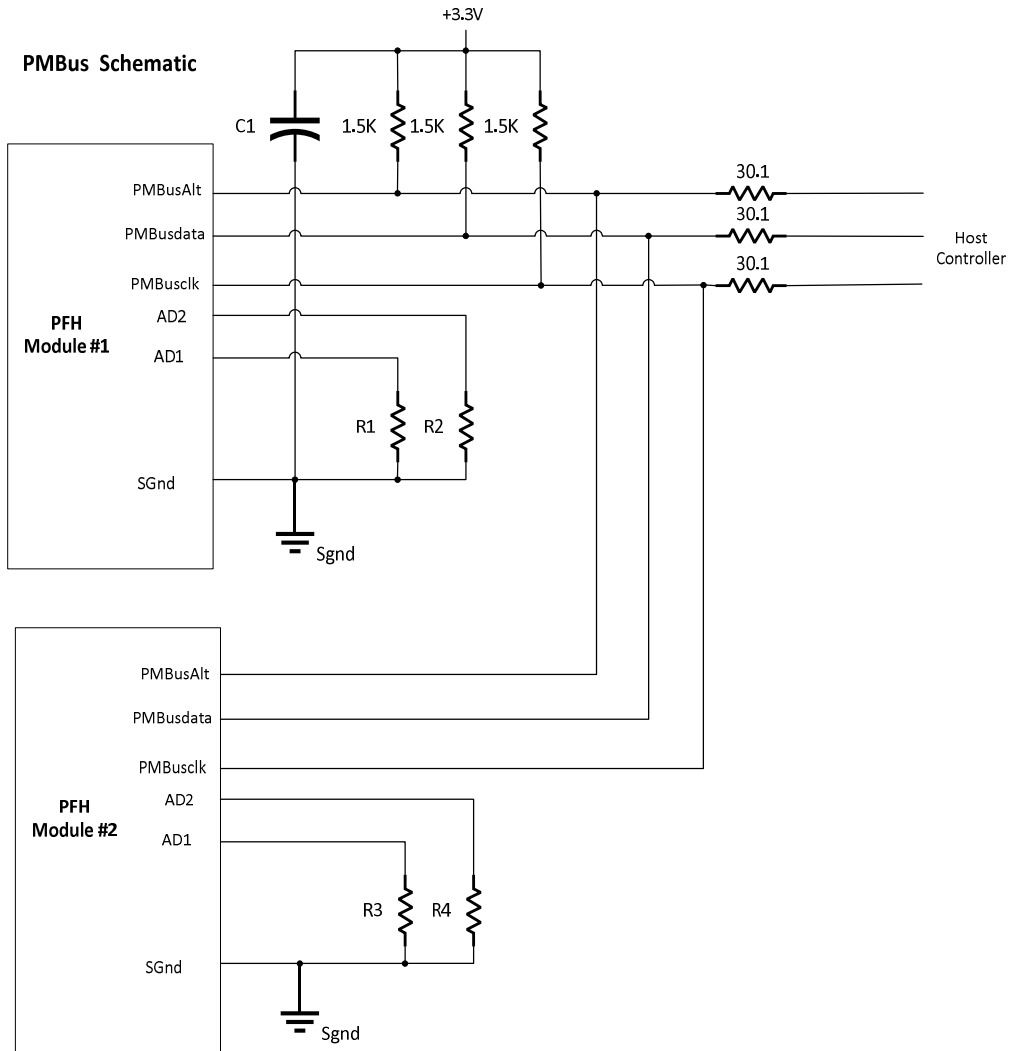

The resistor values are sensed at initialization only.
 The resistor values, for the respective PMBus addresses, are listed in the following table.

NOTE:

- (*) These addresses are reserved by the SMBus specification and cannot be used
- The Address highlighted in Yellow is reserved by the factory and should not be used

PMBus Address Selection:

Address (Hex)	AD2	AD1	Address (Hex)	AD2	AD1	Address (Hex)	AD2	AD1	Address (Hex)	AD2	AD1
0	0	0	20	10000	0	40	20000	0	60	36500	0
1	0	1000	21	10000	1000	41	20000	1000	61	36500	1000
2	0	10000	22	10000	10000	42	20000	10000	62	36500	10000
3	0	15000	23	10000	15000	43	20000	15000	63	36500	15000
4	0	20000	24	10000	20000	44	20000	20000	64	36500	20000
5	0	28000	25	10000	28000	45	20000	28000	65	36500	28000
6	0	36500	26	10000	36500	46	20000	36500	66	36500	36500
7	0	49900	27	10000	49900	47	20000	49900	67	36500	49900
8	0	69800	28	10000	69800	48	20000	69800	68	36500	69800
9	0	Open	29	10000	Open	49	20000	Open	69	36500	Open
10	1000	0	30	15000	0	50	28000	0	70	49900	0
11*	-	-	31	15000	1000	51	28000	1000	71	49900	1000
12*	-	-	32	15000	10000	52	28000	10000	72	49900	10000
13	1000	15000	33	15000	15000	53	28000	15000	73	49900	15000
14	1000	20000	34	15000	20000	54	28000	20000	74	49900	20000
15	1000	28000	35	15000	28000	55	28000	28000	75	49900	28000
16	1000	36500	36	15000	36500	56	28000	36500	76	49900	36500
17	1000	49900	37	15000	49900	57	28000	49900	77	49900	49900
18	1000	69800	38	15000	69800	58	Reserved 28000	Reserved 69800	78*	-	-
19	1000	Open	39	15000	Open	59	28000	Open	79*	-	-

These values are based on the specifications provided by the vendor of the PMBus controller
 All resistors should be 1% tolerance or better

Detailed Descriptions of the Supported PMBus Commands

Vout_Mode:

The VOUT_MODE command is used to retrieve the information about the data format for the VOUT_COMMAND.

VOUT_MODE Data Byte Format (Read Only)		
Command Used 0x20		
Mode:	Bits [7:5]	Bits [4:0] (Parameter)
Linear	000b	Five bit two's complement exponent for the mantissa delivered as the data byte for an output voltage related command.

Vout_Command:

The VOUT_COMMAND is used to set the output voltage.

VOUT_COMMAND (Read/Write)		
Command Used 0x21 Firmware Version 3.3.7 or lower		
Mode:	Bits [15:11]	Bits [10:0] (Parameter)
Linear	5 bit, two's complement integer.	Unsigned 11-bit mantissa
Command Used 0x21 Firmware Version 3.3.8 or Higher		
Mode:	Bits [15:0] (Parameter)	
Linear	Unsigned 16-bit mantissa	
High Limit is $V_{nom} \times 1.2$ Low limit is $V_{nom} \times 0.65$		

Vout_Droop:

The VOUT_DROOP command is used to read the droop rate of the current share circuit. The value is in mV/A.

VOUT_DROOP (Read Only)		
Command Used 0x28		
Mode:	Bits [15:11]	Bits [10:0] (Parameter)
Linear	5 bit, two's complement integer.	Unsigned 11-bit mantissa

Vout_OV_Fault_Limit:

The VOUT_OV_FAULT_LIMIT command is used to read and change the Over Voltage fault trip limit.

VOUT_OV_FAULT_LIMIT (Read/Write)		
Command Used 0x40		
Mode:	Bits [15:11]	Bits [10:0] (Parameter)
Linear	5 bit, two's complement integer.	Unsigned 11-bit mantissa
High Limit = 1.58 x Vdivider Low Limit = Vout Normal		
Vdivider = 9.70 for 12V module Vdivider = 23.55 for 28V module Vdivider = 42.00 for 48V module		

OT_Fault_limit:

The OT_FAULT_LIMIT command is used to read and change the Over Temperature fault trip limit.

OT_FAULT_LIMIT (Read/Write)		
Command Used 0x4F		
Mode:	Bits [15:11]	Bits [10:0] (Parameter)
Linear	5 bit, two's complement integer.	Unsigned 11-bit mantissa
High Limit = 112°C Low Limit = 65°C		

NOTE: The Over Temperature limits of the module are input voltage dependent for firmware 3.3.7 and below
 At input voltages less than 130Vrms, the Over Temperature limits cannot be changed
 The OT_Fault_Limit is only effective when the AC input voltage is above 130Vrms
 The OT_Fault_limit for input voltages above 130V is 112°C
 The OT_Fault_limit for input voltages between 130V and 116V is 116°C
 The OT_Fault_limit for input voltages below 116V is 114°C

I_Out_OC_Fault Limit:

The I_OUT_OC_FAULT_LIMIT command is used to read and change the Output Over Current fault trip limit.

I_OUT_OC_FAULT_LIMIT (Read/Write)		
Command Used 0x46		
Mode:	Bits [15:11]	Bits [10:0] (Parameter)
Linear	5 bit, two's complement integer.	Unsigned 11-bit mantissa
High Limit = Full Load Rating x 1.28 Low Limit = 0		

Vout_UV_Fault_Limit:

The VOUT_UV_FAULT_LIMIT command is used to read and change the Under Voltage fault trip limit.

VOUT_UV_FAULT_LIMIT (Read/Write)		
Command Used 0x44		
Mode:	Bits [15:11]	Bits [10:0] (Parameter)
Linear	5 bit, two's complement integer.	Unsigned 11-bit mantissa
High Limit is V_nom Low limit is V_nom x 0.6		

Read_Temperature_1:

The READ_TEMPERATURE_1 command is used to read the internal temperature of the module (Pin side – Output side of the module)

READ_TEMPERATURE_1 (Read Only)		
Command Used 0x8D		
Mode:	Bits [15:11]	Bits [10:0] (Parameter)
Linear	5 bit, two's complement integer.	Unsigned 11-bit mantissa

NOTE: Min. Temperature that can be read is 0°C (accuracy +-10°C)

Read_Temperature_2:

The READ_TEMPERATURE_2 command is used to read the internal temperature of the module (Heatsink side – Output side of the module)

READ_TEMPERATURE_2 (Read Only)		
Command Used 0x8E		
Mode:	Bits [15:11]	Bits [10:0] (Parameter)
Linear	5 bit, two's complement integer.	Unsigned 11-bit mantissa

NOTE: Min. Temperature that can be read is 55°C (accuracy +-3°C)

Read_Temperature_3:

The READ_TEMPERATURE_3 command is used to read the internal temperature of the module (Heatsink side – Input side of the module)

READ_TEMPERATURE_3 (Read Only)		
Command Used 0x8F		
Mode:	Bits [15:11]	Bits [10:0] (Parameter)
Linear	5 bit, two's complement integer.	Unsigned 11-bit mantissa

NOTE: Min. Temperature that can be read is 55°C (accuracy is +-3°C)

Read_Temperature_4:

The READ_TEMPERATURE_4 command is used to read the internal temperature of the module (Pin side – Input side of the module)

READ_TEMPERATURE_4 (Read Only)		
Command Used 0xDF		
Mode:	Bits [15:11]	Bits [10:0] (Parameter)
Linear	5 bit, two's complement integer.	Unsigned 11-bit mantissa

NOTE: Min. Temperature that can be read is 0°C (accuracy +-10°C)

Read_Vcap:

The READ_VCAP command is used to read the setting for the High Voltage Bus

READ_VCAP (Read Only)		
Command Used 0x8A		
Mode:	Bits [15:11]	Bits [10:0] (Parameter)
Linear	5 bit, two's complement integer.	Unsigned 11-bit mantissa

Read_Vout:

The READ_VOUT command is used to read the Output Voltage of the converter.

READ_VOUT (Read Only)		
Command Used 0x8B		
Mode:	Bits [15:11]	Bits [10:0] (Parameter)
Linear	5 bit, two's complement integer.	Unsigned 11-bit mantissa

Read_Iout:

The READ_IOUT command is used to read the Output Current of the converter.

READ_IOUT (Read Only)		
Command Used 0x8C		
Mode:	Bits [15:11]	Bits [10:0] (Parameter)
Linear	5 bit, two's complement integer.	Unsigned 11-bit mantissa

Read_Frequency:

The READ_FREQUENCY command is used to read the Switching Frequency of the DC/DC converter used in the PFH Module. The value is in KHz.

READ_FREQUENCY (Read Only)		
Command Used 0x95		
Mode:	Bits [15:11]	Bits [10:0] (Parameter)
Linear	5 bit, two's complement integer.	Unsigned 11-bit mantissa

Read_Vin:

The READ_Vin command is used to read the Input Voltage of the converter.

READ_Vin (Read Only)		
Command Used 0x88		
Mode:	Bits [15:11]	Bits [10:0] (Parameter)
Linear	5 bit, two's complement integer.	Unsigned 11-bit mantissa

Read_Iin:

The READ_Iin command is used to read the Input Current of the converter.

READ_Iin (Read Only)		
Command Used 0x89		
Mode:	Bits [15:11]	Bits [10:0] (Parameter)
Linear	5 bit, two's complement integer.	Unsigned 11-bit mantissa

Status_Word:

The STATUS_WORD command returns a summary of the device status

STATUS_WORD (Read Only)		
Command Used 0x79		
BIT	Name	Description
0	Not Supported	
1	Not Supported	
2	Temperature	A temperature fault has occurred
3	Not Supported	
4	Over Current	An over current fault has occurred
5	Over Voltage	An over voltage fault has occurred
6	Off	No voltage present on output
7	Not Supported	
8	Not Supported	
9	Other	An External Bias fault has occurred
10	Not Supported	
11	Power Good	Power Good signal is active
12	MFR	The module has an illegal configuration
13	Input	An input related fault has occurred
14	Over Current	An over current fault has occurred
15	Vout	An output related fault has occurred

Status_Mfr_Specific:

The STATUS_MFR_SPECIFIC command returns a summary of the device status

STATUS_MFG_SPECIFIC (Read Only)		
Command Used 0x80		
BIT	Name	Description
0	Not Supported	
1	On/Off	Modules On/Off condition
2	Over Current	An over current fault has occurred
3	Over Voltage	An over voltage fault has occurred
4	Temperature	A temperature fault has occurred
5	Bias	An External Bias fault has occurred
6	PFC	An input related fault has occurred
7	Not Supported	
8	Under Voltage	An under voltage fault has occurred
9	Not Supported	
10	Not Supported	
11	Not Supported	
12	Not Supported	
13	Not Supported	
14	Not Supported	
15	Configuration	The module has an illegal configuration

SMBAlert_Mask:

The SMBALERT_MASK command is used to prevent a fault condition from asserting the ALERT# signal. The bits in the mask byte align with the bits in the Status_Mfr_Specific register. Setting any bit will enable the corresponding alarm bit to trigger the ALERT# signal. (Default = x00)

Alert Mask (Read/Write)	
Command Used 0x1B	
BIT	Name
0	Not Supported
1	On/Off
2	Over Current
3	Over Voltage
4	Over Temperature
5	External Bias
6	PFC
7	Not Supported
8	Under Voltage
9	Not Supported
10	Not Supported
11	Not Supported
12	Not Supported
13	Not Supported
14	Not Supported
15	Configuration Over Flow

Operation:

OPERATION command can turn the device on and off through the PMBus.

OPERATION (Write Only)				
Command Used 0x01				
Bits [7:6]	Bits [5:4]	Bits [3:2]	Bits [1:0]	Description
00	XX	XX	XX	Turn Module Off
01	XX	XX	XX	Turn Module Off
10	00	XX	XX	Turn Module On
10	01	XX	XX	Turn Module Off
10	10	XX	XX	Turn Module Off

*** Value 0x8x will turn the module on, any other value will turn the module off**

**** Whichever mode is used (PMBus or On/OFF Pin) to turn the module on,**

The same mode must be used to turn the module off

Read_MFR_ID:

The READ_MFR_ID command is used to read Identification of the manufacture

READ_MFR_ID (Read Only)	
Command Used 0x99	
Mode:	Bytes
text	Ascii

Read_MFR_MODEL:

The READ_MFR_MODEL command is used to read Model number of the module

READ_MFR_MODEL (Read Only)	
Command Used 0x9A	
Mode:	Bytes
text	Ascii

Read_MFR_REVISION:

The READ_MFR_REVISION command is used to read version number of the firmware

READ_MFR_REVISION (Read Only)	
Command Used 0x9B	
Mode:	Bytes
text	Ascii

Read_MFR_LOCATION:

The READ_MFR_LOCATION command is used to read location of the manufacture

READ_MFR_LOCATION (Read Only)	
Command Used 0x9C	
Mode:	Bytes
text	Ascii

Read_MFR_DATE:

The READ_MFR_ID command is used to read release date of the firmware

READ_MFR_DATE (Read Only)	
Command Used 0x9D	
Mode:	Bytes
text	Ascii

Read_MFR_SUPPORT:

The READ_MFR_SUPPORT command is used to get the phone number of the support line for the product

READ_MFR_SUPPORT (Read Only)	
Command Used 0x9F	
Mode:	Bytes
text	Ascii

PMBus_Revision:

The PMBUS_REVISION command reads the revision of the PMBus to which the device is compliant.

PMBus Reserved Commands:

The PMBUS Reserved commands should not be executed as unknown results will result and could render the module useless.

Save User Data:

The SAVE_DATA command is used to save all the user adjustable values to ROM.

SAVE_USER_DATA (Write Only)	
Command Used 0x15	

Restore User Data:

The RESTORE_USER_DATA command is used to restore all user adjustable values from ROM.

RESTORE_USER_DATA (Read Only)		
Command Used 0x16		
Mode:	Bits [15:11]	Bits [10:0] (Parameter)
Linear	5 bit, two's complement integer.	Unsigned 11-bit mantissa

Returns the current output voltage set point

Restore Manufactures Data:

The RESTORE_MANUFACTURES_DATA command is used to restore all adjustable values Back to original manufactures settings.

RESTORE_USER_DATA (Read Only)		
Command Used 0x14		
Mode:	Bits [15:11]	Bits [10:0] (Parameter)
Linear	5 bit, two's complement integer.	Unsigned 11-bit mantissa

Returns the current output voltage set point

NOTE: When using this command the module needs to be in Stand-By Mode

The module supports a maximum clock rate of 400 kHz.

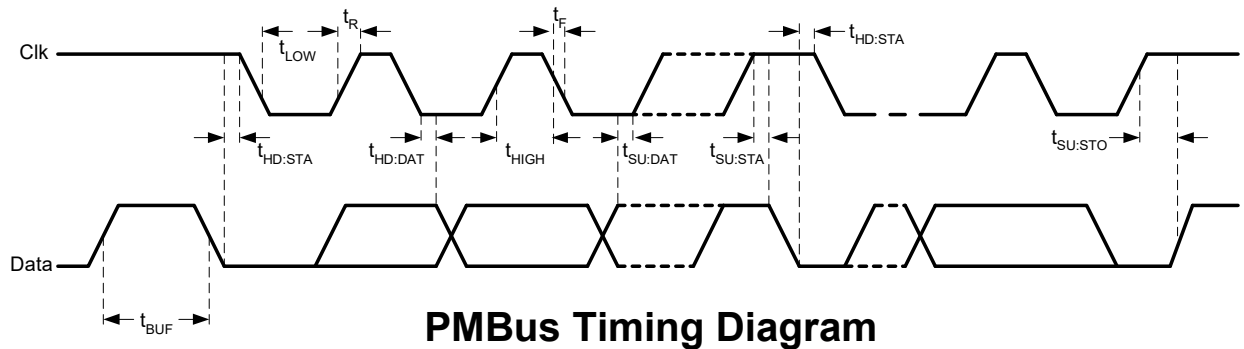

PMBus Timing Diagram

Symbol	Parameter	Typ	Max	Units
T_{BUF}	BUS Free Time Between Stop and Start	1.3		μ S
$T_{HD:STA}$	Hold Time After (Repeated) Start Condition. After This Period The First Clock Is Generated	0.6		μ S
$T_{SU:STA}$	Repeated Start Condition Setup Time	0.6		μ S
$T_{SU:STO}$	Stop Condition Setup Time	0.6		μ S
$T_{HD:DAT}$	Data Hold Time	0		nS
$T_{SU:DAT}$	Data Setup Time	100		nS
T_{LOW}	Clock Low Period	1.3		μ S
T_{HIGH}	Clock High Period	0.6		μ S
T_F	Clock/Data Fall Time		300	nS
T_R	Clock/Data Rise Time		300	nS

PFH Sequence Timing:

PFH Sequence Timing Chart

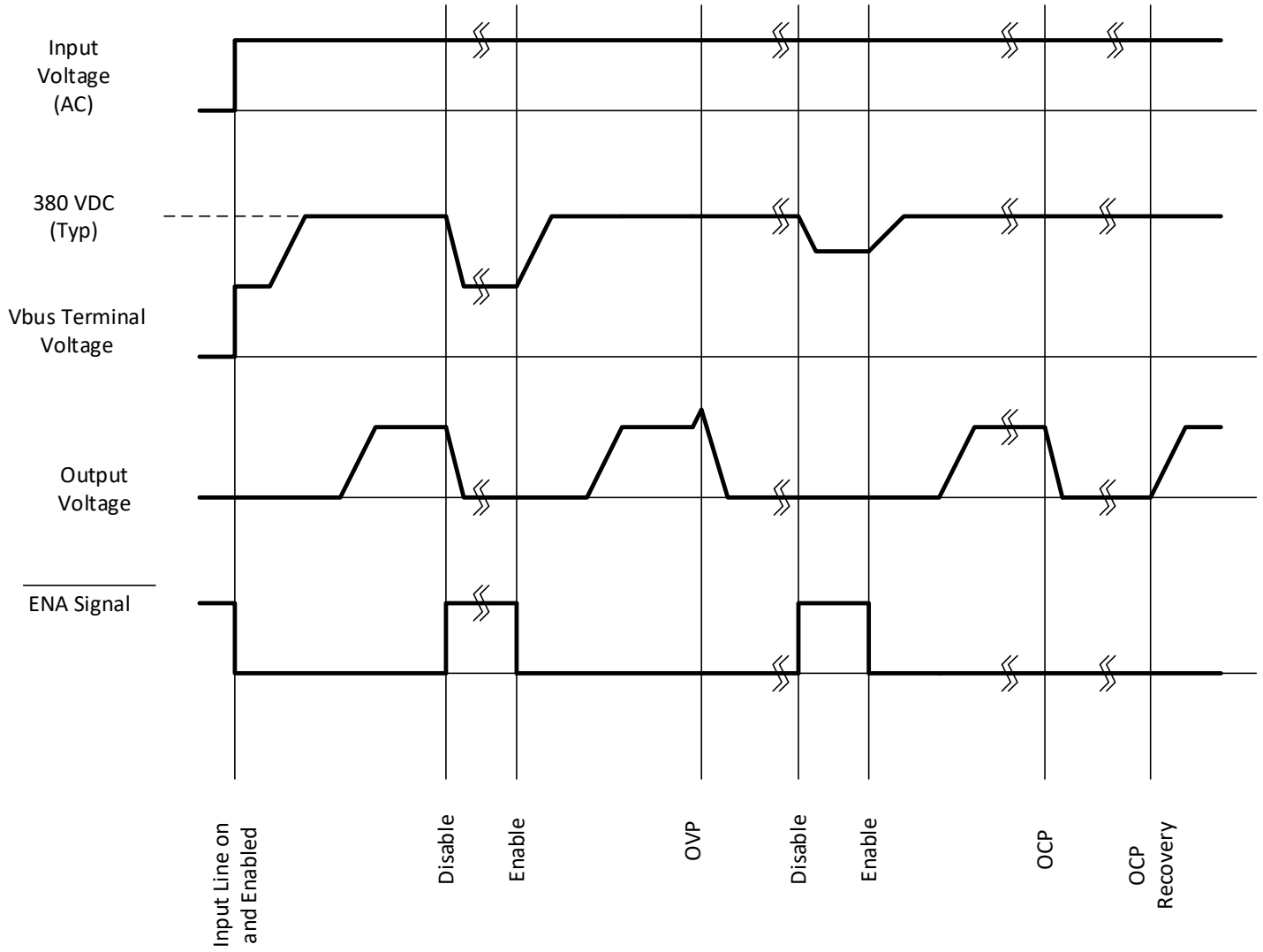

PFH Startup/Shutdown Timing:

PFH Timing Diagram

