



EMC Filters

**3-phase line reactors for converters
4 A ... 900 A, 40 °C, 50/60 Hz**

Series/Type: B86305L

Date: April 2026

3-phase line reactors for converters
3-phase line reactors for converters
Rated voltage V_R : 520 V AC
Rated current I_R : 4 A to 900 A
Construction

- 3-phase line reactor
- Natural cooling

Features

- Easy to install
- Low weight
- Compact design
- Design complies with IEC 60076-6
- Degree of protection¹⁾:
 - IP20 (4 A ... 21 A, 35 A, 46 A)
 - IP10 (30 A, 50 A, 60 A)
 - IP00 (75 A ... 900 A)
- Inductance constant up to $1.5 \times I_R$
- Inductance higher than 60% of rated value at $3 \times I_R$
- UL approved insulation system class 155 (F)

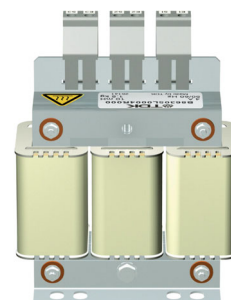
Typical applications

- Frequency converters for motor drives, e.g.
 - elevators
 - pumps
 - traction systems
 - conveyor systems
 - HVAC systems (heating, ventilation and air conditioning)
- Power supplies

Terminals

- Finger-safe terminals (< 75 A)
- Busbars from 75 A

Marking

- Marking on component:
 - Manufacturer's logo, ordering code, rated current, rated frequency, inductance, approximate weight, date code
- Minimum data on packaging:
 - Manufacturer's logo, ordering code, quantity, date code

1) According to IEC 60529

3-phase line reactors for converters
Technical data and measuring conditions

Rated voltage V_R	520 V AC (50/60 Hz)
Rated current I_R	Referred to 40 °C rated temperature
Test voltage V_{test}	1100 V DC, 2 s (line/line) 2500 V DC, 2 s (lines/case)
Relative voltage drop v_k in %	At I_R ; 50 Hz and 400 V AC
Insulation class	155 (F)
Overload capability (thermal)	$3 \cdot I_R$, $t < 3$ s in 300 s
Climatic category (IEC 60068-1)	25/100/21 (−25 °C/+100 °C/21 days damp heat test)
Approvals	Insulation system class 155 (F)

Characteristics and ordering codes

$I_R^{*)}$ A	Terminal cross section mm ²	v_k %	$R_{typ}^{1)}$ mΩ	$L_R^{2)}$ mH	$P_L^{3)}$ W	Approx. weight kg	Ordering code
$V_R = 520$ V AC							
4	4	5.4	335.0	10.0	25	1.5	B86305L0004R000
7	4	4.0	112.0	4.2	31	2.1	B86305L0007R000
10	4	5.4	78.0	4.0	43	2.6	B86305L0010R000
11	4	3.6	63.0	2.6	37	2.5	B86305L0011R000
16	4	4.4	42.2	2.0	65	3.0	B86305L0016R000
21	4	4.0	24.0	1.4	62	4.8	B86305L0021R000
30	16	4.1	12.4	1.0	62	5.5	B86305L0030R000
35	10	4.0	11.0	0.84	80	6.6	B86305L0035R000
46	16	4.0	8.0	0.64	94	8.5	B86305L0046R000
50	16	4.1	7.8	0.6	120	8.4	B86305L0050R000
60	35	4.1	6.2	0.5	100	8.5	B86305L0060R000
75	20 x 3	4.1	5.7	0.4	170	12.0	B86305L0075S000
100	20 x 3	4.1	3.2	0.3	160	15.0	B86305L0100S000
156	20 x 3	4.2	1.47	0.2	250	21.5	B86305L0156S000
230	20 x 3	4.7	0.9	0.15	340	32.0	B86305L0230S000
390	30 x 5	4.0	0.46	0.075	400	49.2	B86305L0390S000
600	40 x 5	4.1	0.3	0.05	650	65.5	B86305L0600S000
800	50 x 5	4.1	0.2	0.038	880	84.5	B86305L0800S000
900	50 x 5	4.2	0.19	0.034	990	90.5	B86305L0900S000

*) Higher current values on request

1) Typical value at 20 °C

2) at I_R , Tolerance −0%/+20%

3) at I_R , 50 Hz and 20 °C

Dimensional drawings

B86305L0004R000 ... B86305L0021R000 (4 A ... 21 A)

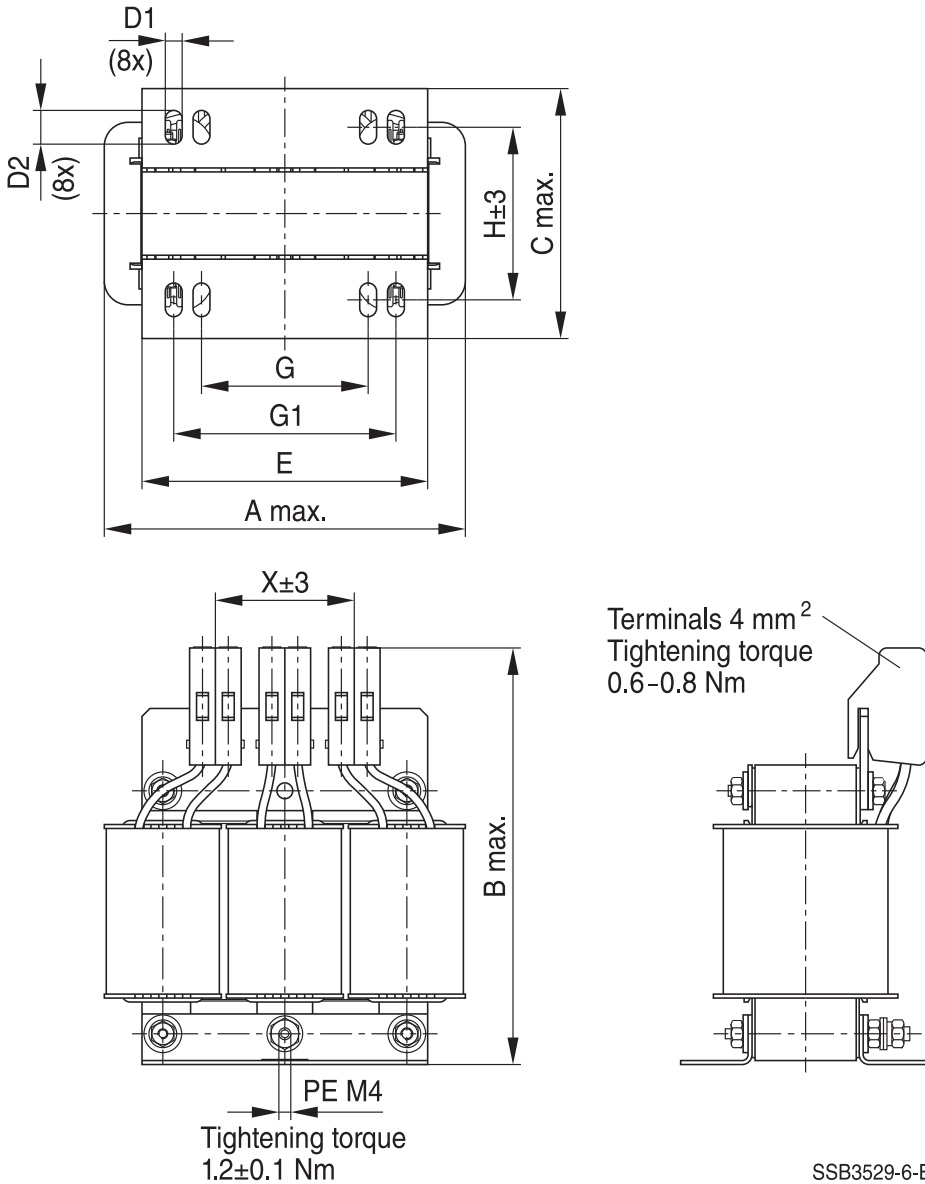

Ordering code	A	B	C	D1 x D2	E	G	G1	H	X
B86305L0004R000	100	135	63	6 x 9	80	40	60	41.5	40
B86305L0007R000	124	123	93	6 x 12	100	60	80.5	60	34
B86305L0010R000	130	150	92	6 x 12	100	60	80.5	60	50
B86305L0011R000	124	123	93	6 x 12	100	60	80.5	60	34
B86305L0016R000	130	150	92	6 x 12	100	60	80.5	60	50
B86305L0021R000	154	149	117	6 x 12	125	75	107	88	50

General tolerances according to ISO 2768-cL
Dimensions in mm

B86305L0035R000, B86305L0046R000 (35 A, 46 A)

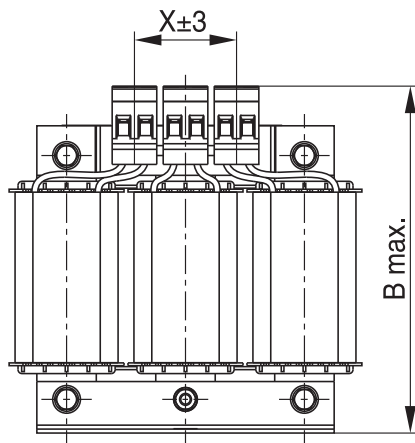
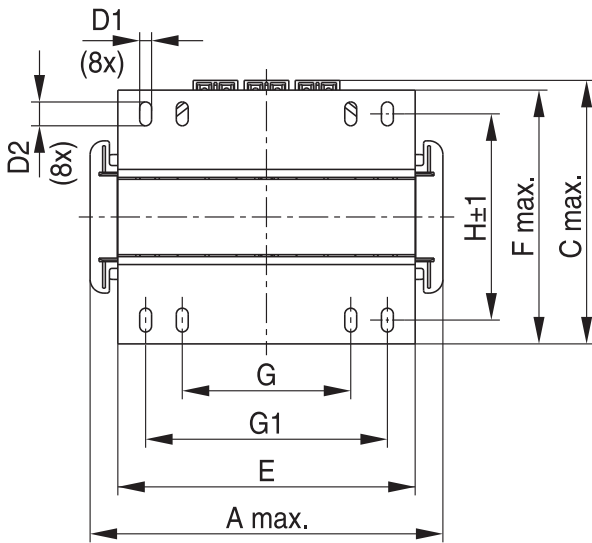

Terminals 10 mm²
Tightening torque 1.2-1.4 Nm

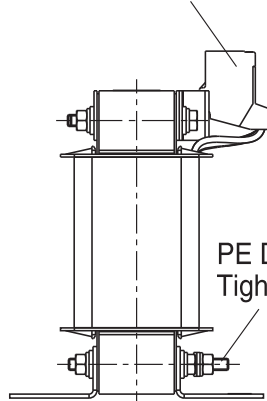

PE D
Tightening torque M Nm

SSB3055-S-E

Ordering code	A	B	C	D1 x D2	E	F	G	G1	H	X	D	M (Nm)
B86305L0035R000	154	153	137	6 x 12	125	127	75	107	98	51.5	M4	1.2 ±0.1
B86305L0046R000	183	180	138	6 x 12	150	133	85	122	104	51.5	M6	3.0 ±0.15

General tolerances according to ISO 2768-cL
Dimensions in mm

3-phase line reactors for converters

B86305L0030R000, B86305L0050R000, B86305L0060R000 (30 A, 50 A, 60 A)

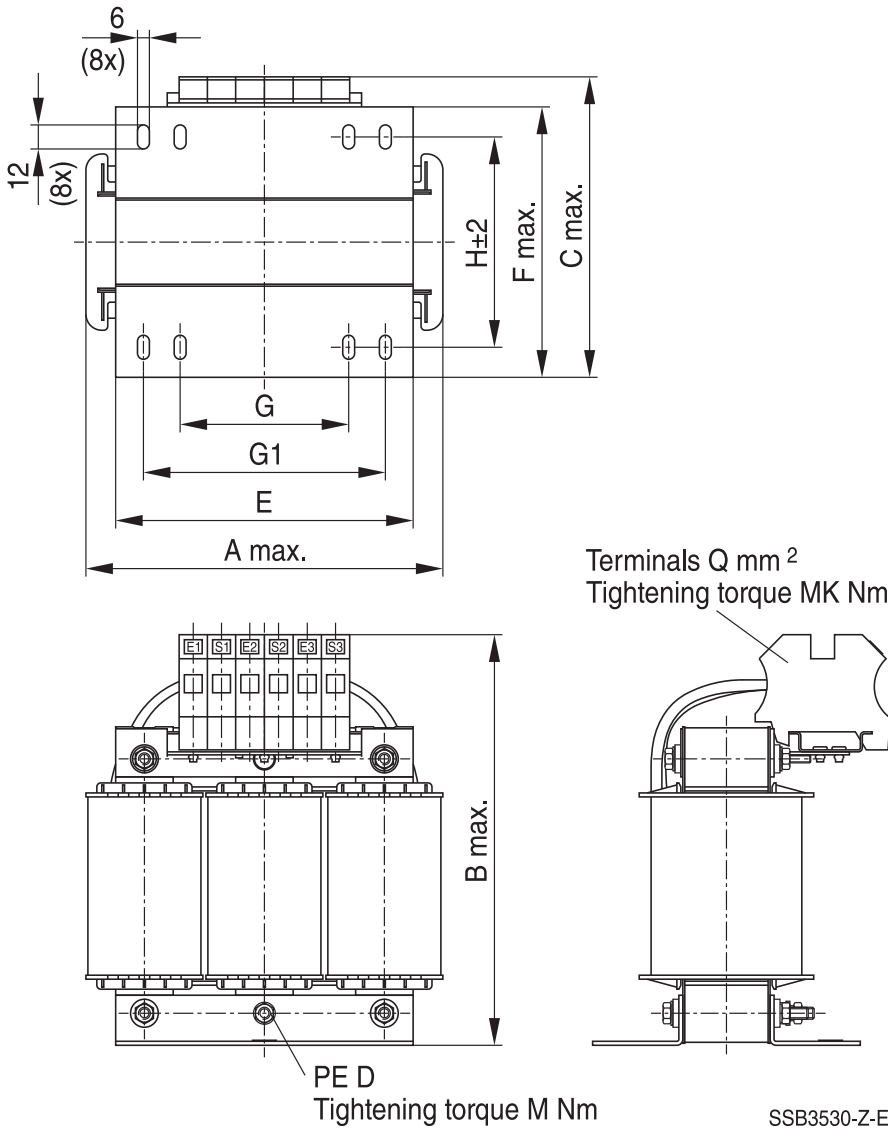

Ordering code	A	B	C	E	F	G	G1	H	Q (mm ²)	MK (Nm)	D	M (Nm)
B86305L0030R000	155	170	135	125	120	75	107	88	16	2.0–2.3	M4	1.2 ±0.1
B86305L0050R000	185	202	150	150	131	85	122	104.5	16	2.0–2.3	M6	3.0 ±0.15
B86305L0060R000	180	205	150	150	135	85	122	104	35	4.0–5.0	M6	3.0 ±0.15

General tolerances according to ISO 2768–cL
Dimensions in mm

3-phase line reactors for converters

B86305L0075S000 (75 A)

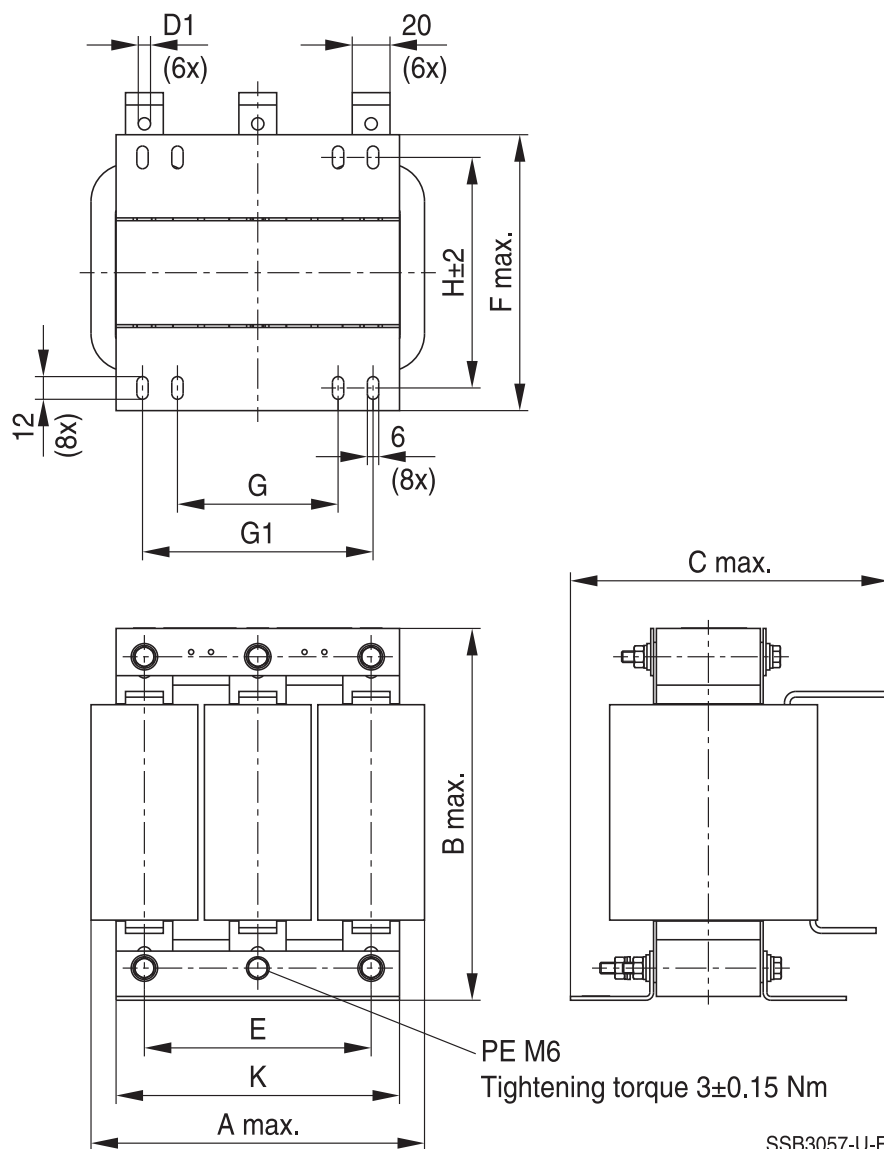

Ordering code	A	B	C	ØD	E	F	G	G1	H	K
B86305L0075S000	185	202	175	6.5	120	148	85	122	122	150

General tolerances according to ISO 2768-cL

Dimensions in mm

Busbar connection see section "Mechanical properties"

B86305L0100S000 ... B86305L0390S000 (100 A ... 390 A)

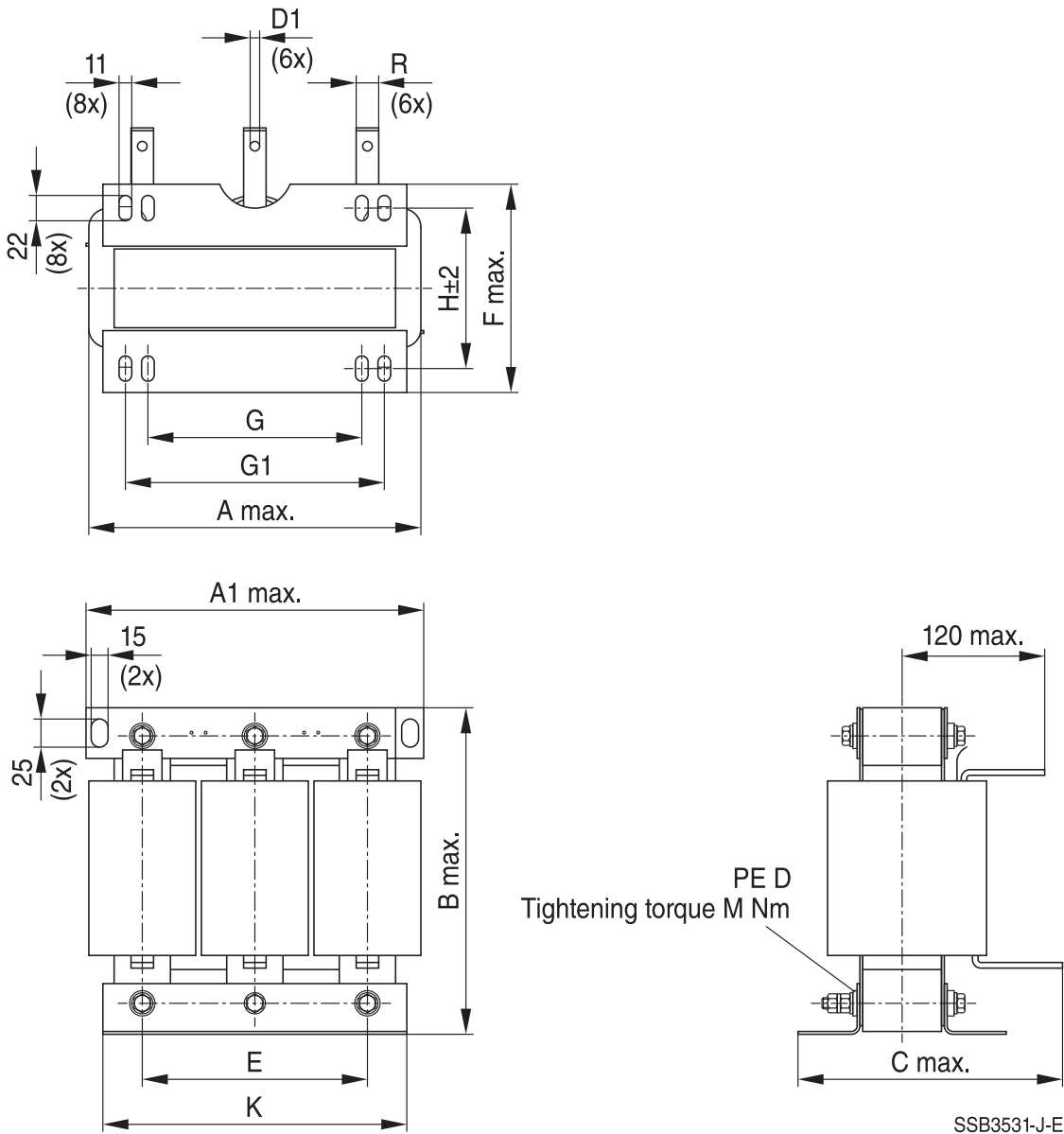

SSB3531-J-E

Ordering code	A	A1	B	C	ØD1	E	F	G	G1	H	K	D	M (Nm)	R
B86305L0100S000	270	270	210	180	6.5	180	145	105	181	100	240	M8	6 ±0.3	20
B86305L0156S000	280	273	215	200	8.5	180	155	105	181	113	240	M8	6 ±0.3	20
B86305L0230S000	320	300	290	235	8.5	200	185	190	230	142	270	M10	10 ±1	20
B86305L0390S000	320	304	300	235	11	200	210	190	230	169	270	M8	6 ±0.3	30

General tolerances according to ISO 2768-cL

Dimensions in mm

Busbar connection see section "Mechanical properties"

B86305L0600S000 ... B86305L0900S000 (600 A ... 900 A)

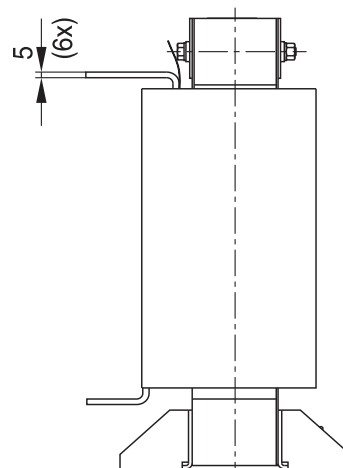
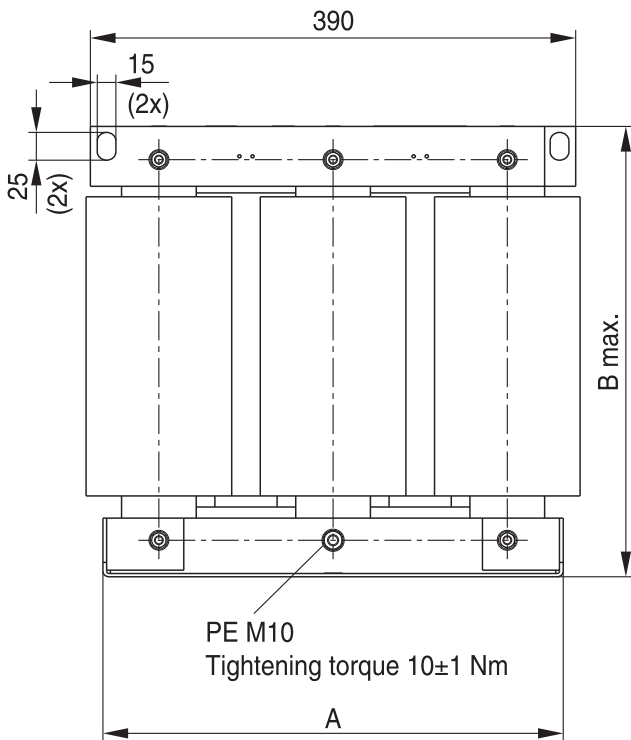
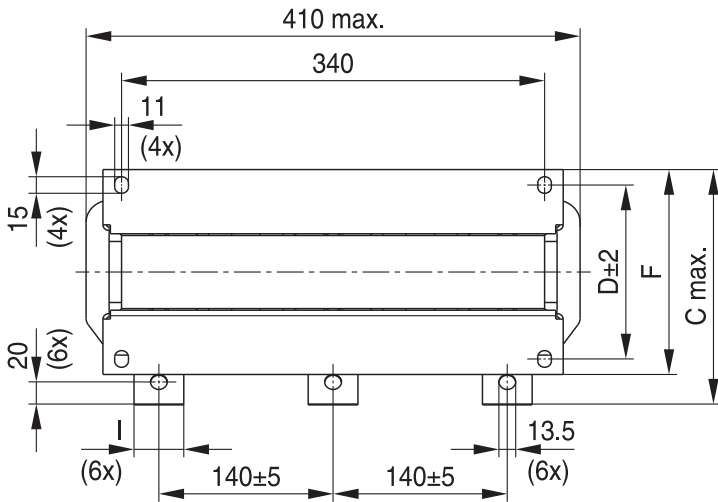

SSB3455-5-E

Ordering code	A	B _{max.}	C _{max.}	D	I	F _{max.}
B86305L0600S000	370	410	230	157	40	190
B86305L0800S000	370	470	250	167	50	200
B86305L0900S000	370	470	260	177	50	210

General tolerances according to ISO 2768–cL

Dimensions in mm

Busbar connection see section “Mechanical properties”

3-phase line reactors for converters
Cautions and warnings

- Please note further advice in our website www.tdk-electronics.tdk.com/pemc_filters_gti
- It shall be ensured that only qualified persons (electricity specialists) are engaged on work such as planning, assembly, installation, operation, repair and maintenance. They must be provided with the corresponding documentation.
- Danger of electric shock: The products contain components that store an electric charge. Dangerous voltages can continue to exist at the product terminals for longer than five minutes even after the power has been switched off.
- The protective earth connections shall be the first to be made when the product is installed and secured against loosening by defined tightening torque. Remove them at last, when uninstalling. Depending on the magnitude of the leakage currents, the particular specifications for making the protective-earth connection must be observed.
- Impermissible overloading of the product, such as with circuits able to cause resonances, impermissible voltages at higher frequencies etc. can lead to bodily injury and death as well as cause substantial material damages (e.g. destruction of the product housing).
- The products must be protected in the application against impermissible exceeding of the rated currents by overcurrent protective devices.
- For leakage currents >10 mA, a fixed connection of the protective earth conductor to the public power grid is required. This means that connection via plug connectors is not permitted. The protective conductor must have a minimum cross-section of 10 mm² Cu or 16 mm² Al over its entire length. Alternatively, two separate protective conductors with the minimum cross-section specified in each case can also be connected.
- For leakage currents 3.5 mA $< I_{LK}^a) \leq 10$ mA, the following solutions are possible:
 - Stationary device with fixed connection
 - Stationary device with type B plug-in connection (industrial plug-in connection according to IEC 60309) and cross-section ≥ 2.5 mm²
 - Stationary device with type A plug-in connection (non-industrial plug-in device) and additional second protective earth connection
 - Movable equipment with type A plug-in connection and additional second protective earth connection in premises with restricted access
- The products must be protected in the application against impermissible exceeding of the specification parameter.
- The converter output frequency must be within the specified range to avoid resonances and uncontrolled warming of the output chokes and output filters.
- The components can become very hot during operation, there is the risk of burns if touched. The product can remain hot for some time after the power is switched off!
- The products are only to be attached to the fixings or mounting holes provided for this purpose in accordance with the data sheet. It is not permitted for the product specified in the data sheet to assume a mechanical function in the final application, in particular any type of tension or pressure on the product must be prevented.
- With surface-treated sheets (e.g. galvanized), edge rust may occur due to the manufacturing process. This does not constitute a quality defect. Alternative materials are available if required.

a) I_{LK} = Leakage current

Display of ordering codes for TDK Electronics products

The ordering code for one and the same product can be represented differently in data sheets, data books, other publications, on the company website, or in order-related documents such as shipping notes, order confirmations and product labels. The varying representations of the ordering codes are due to different processes employed and do not affect the specifications of the respective products.

Detailed information can be found on the Internet under www.tdk-electronics.tdk.com/orderingcodes.

3-phase line reactors for converters
Symbols and terms

Symbol	English	German
α	Insertion loss	Einfügungsdämpfung
C_R	Rated capacitance	Bemessungskapazität
C_X	Capacitance X capacitor	Kapazität X-Kondensator
C_Y	Capacitance Y capacitor	Kapazität Y-Kondensator
ΔV	Voltage drop (input to output)	Spannungsabfall (Eingang zu Ausgang)
dv/dt	Rate of voltage rise	Spannungsanstiegsgeschwindigkeit
f	Frequency	Frequenz
f_M	Converter output frequency	Motorfrequenz
f_P	Pulse frequency	Pulsfrequenz
f_R	Rated frequency	Bemessungsfrequenz
f_{res}	Resonant frequency	Resonanzfrequenz
I_C	Current through capacitor	Strom durch Kondensator
I_{LK}	Filter leakage current	Filter-Ableitstrom
I_{max}	Maximum current	Maximalstrom
I_N	Nominal current	Nennstrom
I_{op}	Operating current (design current)	Betriebsstrom
I_{pk}	Rated peak withstand current	Bemessungsstoßstromfestigkeit
I_q	Capacitive reactive current	Kapazitiver Blindstrom
I_R	Rated current	Bemessungsstrom
I_S	Interference current	Störstrom
L	Inductance	Induktivität
L_R	Rated inductance	Bemessungsinduktivität
L_{stray}	Stray inductance	Streuinduktivität
P_L	Power loss	Verlustleistung
R	Resistance	Widerstand
R_{is}	Insulation resistance	Isolationswiderstand
R_{typ}	DC resistance, typical value	Gleichstromwiderstand typisch
T_A	Ambient temperature	Umgebungstemperatur
T_{max}	Upper category temperature	Obere Kategorietemperatur

3-phase line reactors for converters

Symbol	English	German
T_{\min}	Lower category temperature	Untere Kategorietemperatur
T_R	Rated temperature	Bemessungstemperatur
v_k	Referred voltage drop in %	Bezogener Spannungsabfall in %
V_{eff}	RMS voltage	Effektivspannung
V_K	Voltage drop	Spannungsabfall
V_{LE}	Voltage line to earth; voltage line to ground	Spannung Phase zu Erdpotential
V_N	Nominal voltage	Nennspannung
V_R	Rated voltage	Bemessungsspannung
V_{peak}	Peak voltage	Spitzenspannung
V_{test}	Test voltage	Prüfspannung
V_X	Voltage over X capacitor	Spannung über X-Kondensator
V_Y	Voltage over Y capacitor	Spannung über Y-Kondensator
X_L	Inductive reactance	Induktiver Blindwiderstand
Z	Impedance	Scheinwiderstand
$ Z $	Impedance, absolute value	Scheinwiderstand (Betragswert)

Important notes

The following applies to all products named in this publication:

- 1 Some parts of this publication contain **statements about the suitability of our products for certain areas of application**. These statements are based on our knowledge of typical requirements that are often placed on our products in the areas of application concerned. We nevertheless expressly point out **that such statements cannot be regarded as binding statements about the suitability of our products for a particular customer application**. As a rule we are either unfamiliar with individual customer applications or less familiar with them than the customers themselves. For these reasons, it is always ultimately incumbent on the customer to check and decide whether a product with the properties described in the product specification is suitable for use in a particular customer application.
- 2 We also point out that **in individual cases, a malfunction of electronic components or failure before the end of their usual service life cannot be completely ruled out in the current state of the art, even if they are operated as specified**. In customer applications requiring a very high level of operational safety and especially in customer applications in which the malfunction or failure of an electronic component could endanger human life or health (e.g. in accident prevention or life-saving systems), it must therefore be ensured by means of suitable design of the customer application or other action taken by the customer (e.g. installation of protective circuitry or redundancy) that no injury or damage is sustained by third parties in the event of malfunction or failure of an electronic component.
- 3 **The warnings, cautions and product-specific notes must be observed.**
- 4 In order to satisfy certain technical requirements, **some of the products described in this publication may contain substances subject to restrictions in certain jurisdictions (e.g. because they are classed as hazardous)**. Useful information on this will be found in our Material Data Sheets on the Internet (www.tdk-electronics.tdk.com/material). Should you have any more detailed questions, please contact our sales offices.
- 5 We constantly strive to improve our products. Consequently, **the products described in this publication may change from time to time**. The same is true of the corresponding product specifications. Please check therefore to what extent product descriptions and specifications contained in this publication are still applicable before or when you place an order.
We also **reserve the right to discontinue production and delivery of products**. Consequently, we cannot guarantee that all products named in this publication will always be available. The aforementioned does not apply in the case of individual agreements deviating from the foregoing for customer-specific products.
- 6 Unless otherwise agreed in individual contracts, **all orders are subject to our General Terms and Conditions of Supply**.
- 7 **Our manufacturing sites serving the automotive business apply the IATF 16949 standard**. The IATF certifications confirm our compliance with requirements regarding the quality management system in the automotive industry. Referring to customer requirements and customer specific requirements ("CSR") TDK always has and will continue to have the policy of respecting individual agreements. Even if IATF 16949 may appear to support the acceptance of unilateral requirements, we hereby like to emphasize that **only requirements mutually agreed upon can and will be implemented in our Quality Management System**. For clarification purposes we like to point out that obligations from IATF 16949 shall only become legally binding if individually agreed upon.

Important notes

- 8 The trade names EPCOS, CarXield, CeraCharge, CeraDiode, CeraLink, CeraPad, CeraPlas, CSMP, CTVS, DeltaCap, DigiSiMic, FilterCap, FormFit, InsuGate, LeaXield, MediPlas, MiniBlue, MiniCell, MKD, MKK, ModCap, MotorCap, PCC, PhaseCap, PhaseCube, PhaseMod, PhiCap, PiezoBrush, PlasmaBrush, PowerHap, PQSine, PQvar, SIFERRIT, SIFI, SIKOREL, SilverCap, SIMDAD, SiMic, SIMID, SineFormer, SIOV, SurfIND, ThermoFuse, WindCap, XieldCap are **trademarks registered or pending** in Europe and in other countries. Further information will be found on the Internet at www.tdk-electronics.tdk.com/trademarks.

Release 2024-02