

CC15-24xxSxx-E , CC30-24xxSxx-E Series Instruction Manual

1. Standard Connection Method

The connection method shown in Figure 1.

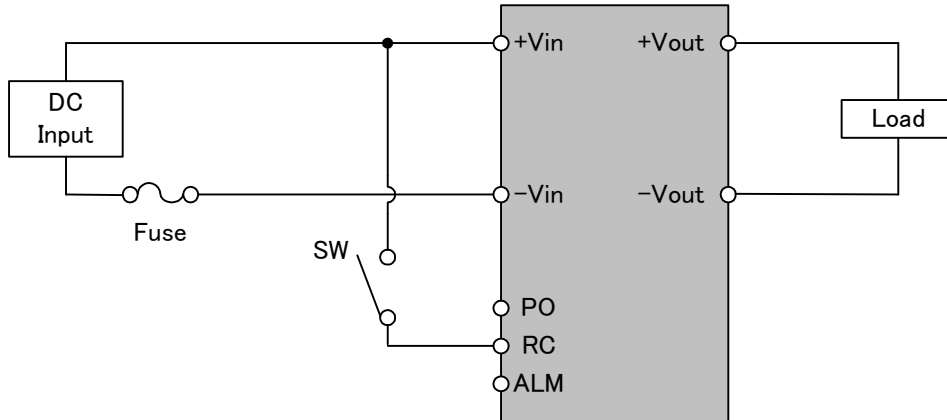

Fig. 1 Connection Method

- When not using the Remote Control function, use it with either the RC terminal open or connected to the -Vin terminal.
- When not using the Alarm function, use it with the ALM terminal in an open condition.
- Use the PO terminal for controlling multiple unit operation (series, parallel operation etc.).  
For single unit operation, use the PO terminal in an open condition.
- The converter is to be operated exclusively on DC input. Use of AC input will cause damage.

2. Block Diagram

The block diagram is shown in Figure 2.

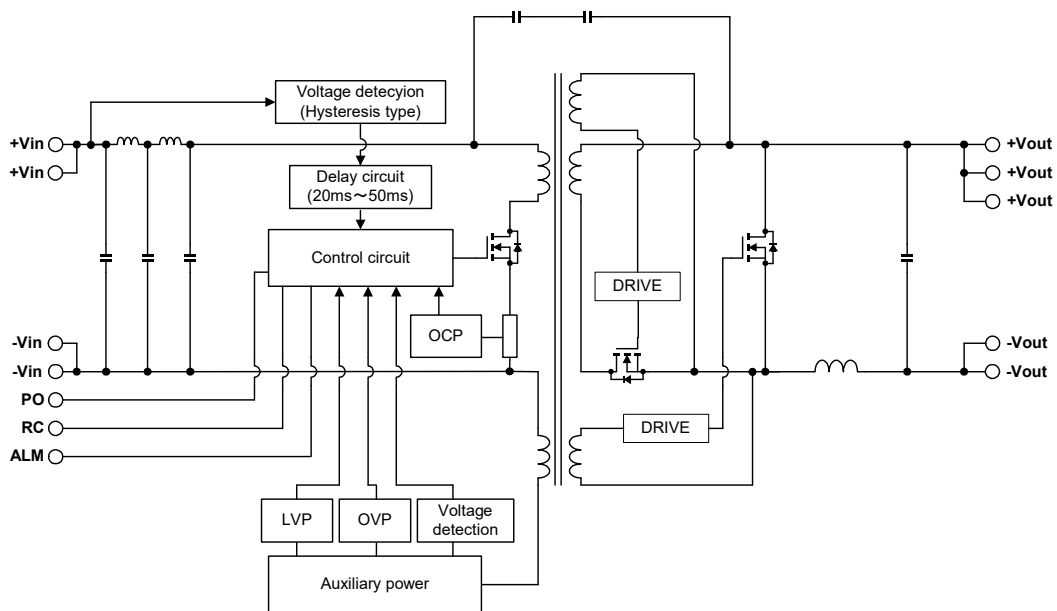

Fig. 2 Block Diagram

※Contact TDK-Lambda concerning items not mentioned or items which are not clear.

### 3. Input / Output Line Connection

#### 3-1 Fuse

Because there is no built-in fuse, use an external fuse in accordance with Table 3-1.

In addition, when supplying input voltage from one DC power supply to multiple DC/DC converters, attach a fast breaking fuse to the input of each converter upon use.

- Put the fuse on the +Vin side when the -Vin side is used for GND, and on the -Vin side when the +Vin side is used for GND.
- When a fuse breaks, the Alarm Signal does not operate.

Table 3-1 Recommended Fuse Capacity

Converter Type	CC15-24xxSxx-E	CC30-24xxSxx-E
Fuse Capacity	2A	4A

#### 3-2 Input Side External Capacitor

This converter is equipped with a capacitor on the input side and does not need an external capacitor to be attached to the input terminal side when the length of the line connection from the DC power source is short (less than 1 meter is estimated).

However, when the line to the input terminal is long, or when the inductance increases, operation may become unstable, therefore insert external capacitor  $C_{in}$  between the +Vin and -Vin terminals.

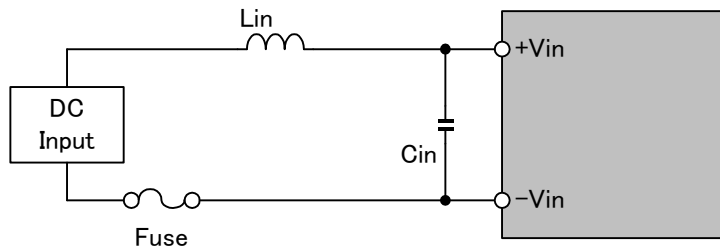

Fig. 3-2-1  $C_{in}$  is necessary when an inductance filter is inserted in the input line.

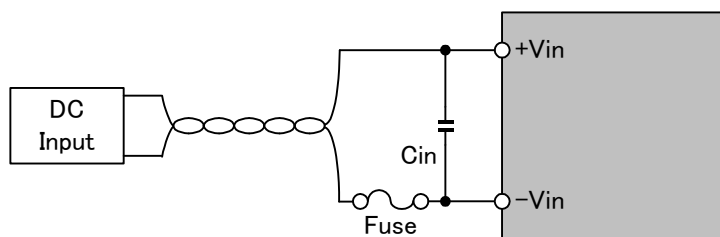

Fig. 3-2-2  $C_{in}$  is necessary when the input line is long.

Table 3-2 Recommended External Capacitor  $C_{in}$  Values

Converter Type	CC15-24xxSxx-E	CC30-24xxSxx-E
Recommended $C_{in}$ Value	33 $\mu$ F	68 $\mu$ F

※Contact TDK-Lambda concerning items not mentioned or items which are not clear.

### 3-3 Input Ripple Noise Voltage Reduction (Noise Terminal Voltage Reduction)

This converter has a built-in input filter circuit, in addition, by connecting an input filter as shown in Figure 3-3, input ripple noise voltage (noise terminal voltage) can be decreased.

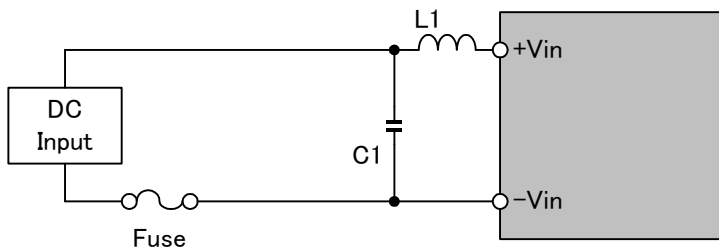

Fig. 3-3 Connection Diagram for Input Ripple Noise Reduction Filter

### 3-4 Prevention of Reverse Connection

This converter does not have a protection circuit to protect against an input voltage reverse polarity connection. Damage may occur if reverse polarity voltage is applied to the input terminal. When the possibility of the application of reverse polarity voltage exists, attach an external protection circuit as shown in Figure 3-4.

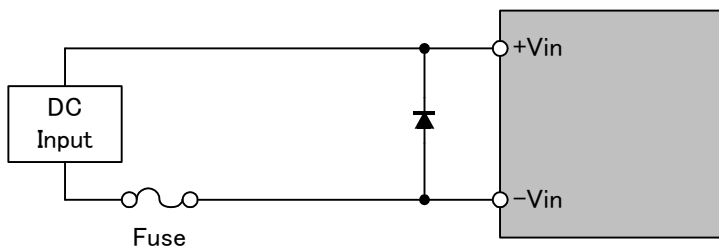

Fig. 3-4 Reverse Connection Prevention Circuit

### 3-5 Output Side External Capacitor

When connecting a pulse load to this converter, connect capacitor Cout between the +Vout and -Vout terminals.

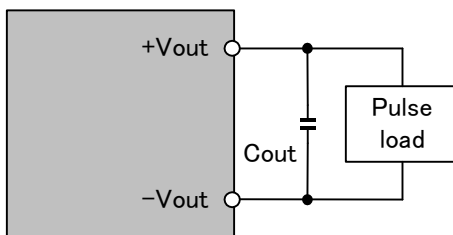

Fig. 3-5 Output Side External Capacitor Connection Method

Table 3-5 Recommended External Capacitor Cout Values

Converter Type	CCxx-2403Sxx-E CCxx-2405Sxx-E (3.3V/5.0V 出力)	CCxx-2412Sxx-E CCxx-2415Sxx-E (12V/15V 出力)
Recommended Cout Value	22 ~ 4700 $\mu$ F	0.1 ~ 2200 $\mu$ F

※Contact TDK-Lambda concerning items not mentioned or items which are not clear.

3-6 Output Ripple Noise Voltage Measurement Method

When measuring the output ripple noise voltage of this converter, the value differs greatly, depending on the measurement method. Measurement is to be made close to the output terminal, do not make a loop when connecting the probe in order to avoid picking up magnetic flux. Also, note that the measured value will vary greatly as a result of the frequency band of the ripple voltmeter or oscilloscope used for measuring. The TDK ripple noise measurement is made according to the method shown in Figure 3-6.

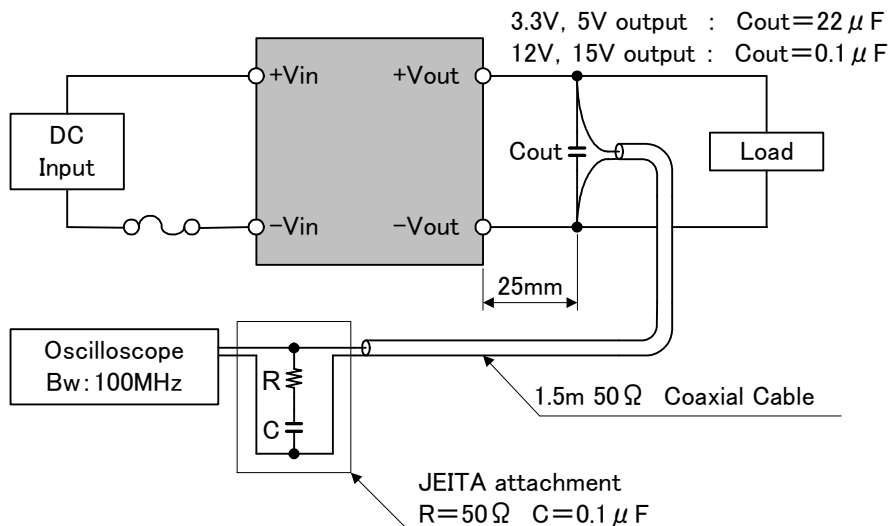

Fig. 3-6 Ripple Noise Voltage Measurement Circuit

【Caution when Adding External Capacitor Cout】

External capacitor Cout may influence the output ripple voltage by the ESR and ESL and inductance of the wiring. In particular, caution is required if low ESR ceramic capacitors, etc. are connected, resonance will occur between the capacitor and the wiring inductance and the ripple component may increase.

※Contact TDK-Lambda concerning items not mentioned or items which are not clear.

#### 4. Terminal Function / Protection Function / Series Connection • Parallel Connection

##### 4-1 Remote Control (RC Terminal)

When the input voltage is in an ON condition, the RC terminal can be used to control output ON/OFF.

When not using the Remote Control function, either open the RC terminal or connect it to the  $-V_{in}$  terminal.

We recommend connection to the  $-V_{in}$  terminal in order to prevent malfunction caused by noise.

Table 4-1-1 RC Terminal Specifications

Logic	RC Terminal Voltage		Output Condition
	Min. [V]	Max. [V]	
L Level	0	1.2	ON
	or Open		
H Level	10	$+V_{in}$	OFF

※ When the  $-V_{in}$  terminal is used for GND.

- If the RC terminal is set at L Level or open condition, the output is ON.
- If the RC terminal is set at H Level, the output is OFF.
- When the converter is in a latch stop condition because of a protection function, after removing the abnormal factor, use the Remote Control to turn the output OFF, then turn ON after the lapse of 1 second minimum for recovery to occur.

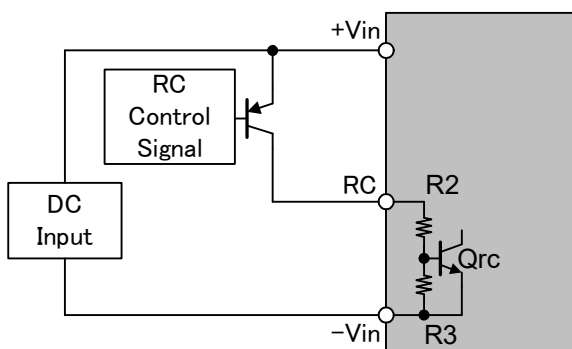

Fig. 4-1-1 RC Terminal Connection Method 1

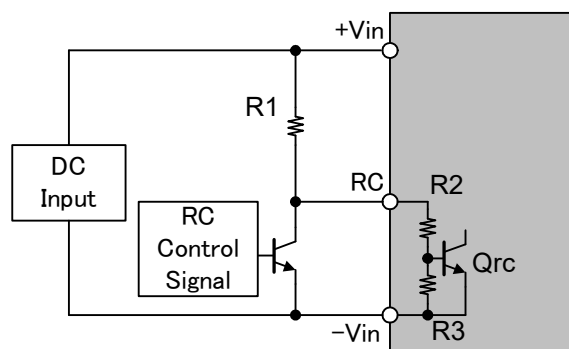

Fig. 4-1-2 RC Terminal Connection Method 2

Table 4-1-2 Recommended Value of External Resistor R1 when using the RC Terminal

Converter Type	CCxx-24xxSxx-E
R1 Recommended Value	22k $\Omega$
R2 (Typical)	91k $\Omega$
R3 (Typical)	15k $\Omega$

When a connection method as shown in Fig. 4-1-1 is used, and if capacitance exists between the  $+V_{in}$  and RC terminals, there is the possibility of the RC terminal voltage becoming unstable because of the capacitance in the case when the input voltage is changed suddenly (it becomes a factor causing malfunction). In that case, we recommend the connection method shown in Fig. 4-1-2. In addition, the rating of the external transistor used is as follows:  $V_{ce}$ : greater than the  $V_{in}$ ,  $I_c$ : minimum 10mA.

※Contact TDK-Lambda concerning items not mentioned or items which are not clear.

#### 4-2 Alarm (ALM Terminal)

By means of the ALM terminal the presence / absence of an abnormal state can be monitored.

When not using the alarm output function, set the ALM terminal in the open condition.

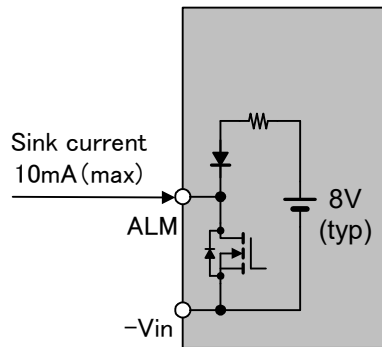

Fig. 4-2 Alarm Terminal Internal Circuit

- When the output turns OFF as a result of over-current protection, low-voltage protection, over-voltage protection, the Alarm Signal will operate. At that time, the ALM terminal voltage is L level (the -Vin terminal is 0.3V or less).
- When multiple units are operated in series or in parallel, etc., and the ALM terminals are connected together, when an abnormality occurs and the alarm signal operates in 1 unit, the other connected units can be stopped.
- Converters having different output voltages can be connected. (This applies only to converters belonging to this series).
- Use the ALM terminal at a maximum sink current of 10mA.
- The maximum number of units to which the ALM terminal can be connected is 20 units.

#### 4-3 Simultaneous Start-Up / Stop (PO Terminal)

By means of the PO terminal, the start-up / stop timing of multiple converter units can be synchronized.

To do so, connect the PO terminals to each other.

When not using the simultaneous start-up / stop function, set the PO terminal in the open position.

- Converters having different output voltages can be connected. (This applies only to converters belonging to this series).
- The maximum number of units to which the PO terminal can be connected is 20 units.

#### 4-4 Over-Current Protection (OCP) & Low-Voltage Protection (LVP)

These converters are equipped with built-in over-current protection and low-voltage protection circuits.

- When the output current exceeds the over-current setting point the over-current protection circuit operates and the output voltage begins to fall. When the output voltage falls below 90% of the rated voltage, the low-voltage protection circuit operates and shuts down the output.
- There is a time lag of approx. 100 ms from the time the LVP circuit detects an abnormality until the output is shut down.
- When the output shuts down, the Alarm signal operates.
- When the output shuts down and operation stops, after the cause of the over-current or low-voltage is removed, recovery can be achieved either by restarting the input power source or by using the remote control function.

#### 4-5 Over-Voltage Protection

These converters are equipped with a built-in over-voltage protection circuit.

- When the output voltage becomes 115%~145% of the rated voltage, the over-voltage protection circuit operates.
- When the output current is less than 50% of the rated current, depending on the failure mode, operation at voltage exceeding the upper limit may occur.
- When the output shuts down, the Alarm signal operates.
- When the output shuts down and operation stops, after the cause of the over-current or low-voltage is removed, recovery can be achieved either by restarting the input power source or by using the remote control function.

#### 4-6 Operation Sequence

The input voltage, output voltage, RC, PO, ALM terminal operation sequence of these converters is shown in Figure 4-6.

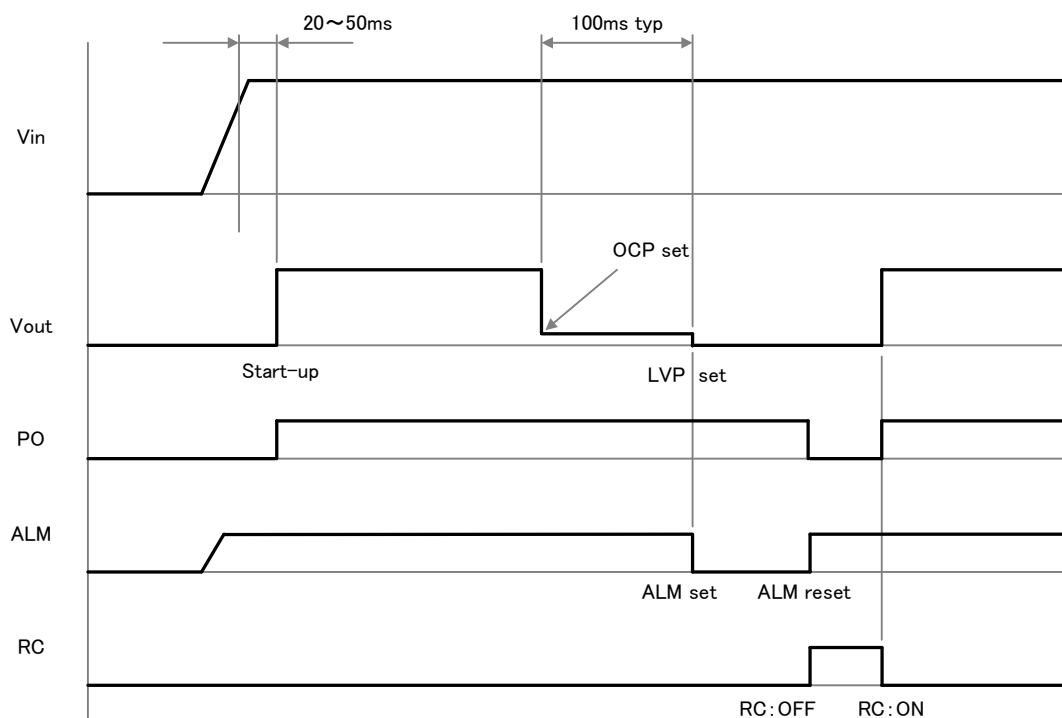

Fig. 4-6 Sequence Chart

※Contact TDK-Lambda concerning items not mentioned or items which are not clear.

### 4-7 Series Operation

For this converter series, it is possible to operate models of the same type in series.

- The maximum number of converters which can be operated in series is 2.
- When using series operation, connect the +Vin terminal, -Vin terminal, PO terminal and ALM terminal of each converter to the same terminal of the other.

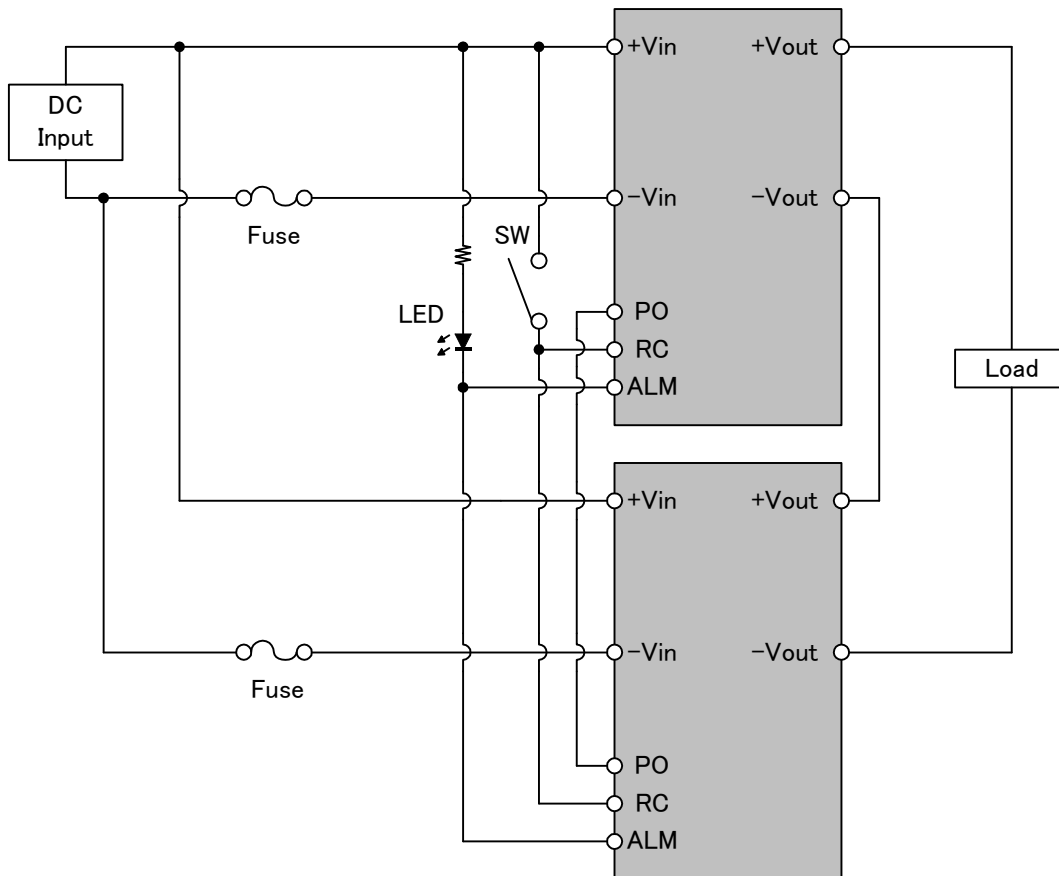

Fig. 4-7 Example Series Operation Connection



### 4-8 Parallel Operation

For this converter series, it is possible to operate models of the same type in parallel.

- The maximum number of converters which can be operated in parallel is 10.
- When using parallel operation, connect the PO terminal and ALM terminal of each converter to the same terminal of the other.
- As much as possible, insure that the width, length and material of the wiring used for connecting each converter to the load are identical. There is the possibility that the current balance will collapse if there is a difference in the wiring from each respective converter to the load.

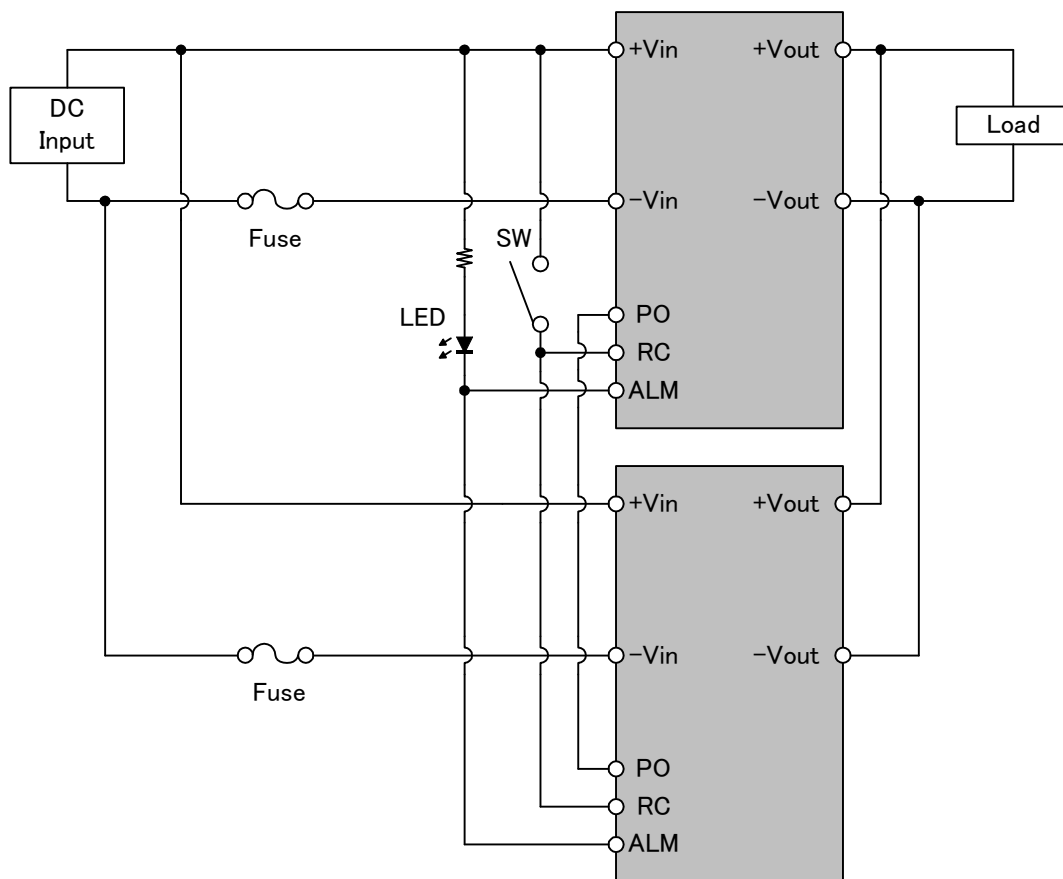

Fig. 4-8 Example Parallel Operation Connection

## 5. Soldering Conditions / Cleaning Conditions / Installation Method

### 5-1 Soldering Conditions

#### 【DIP Model】

Perform soldering of the converter to the board according to the conditions shown in Table 5-1.

- Soldering is to be performed only one time per pin.

Table 5-1 Solder Conditions for DIP Models

Method	Condition
Solder Dip	260°C 10 sec Max.
Solder Iron	380°C 3 sec Max.

#### 【SMD Model】

Lead free solder / high temperature reflow process conditions are shown in Figure 5-1.

- The number of times permitted for reflow is 1 time.

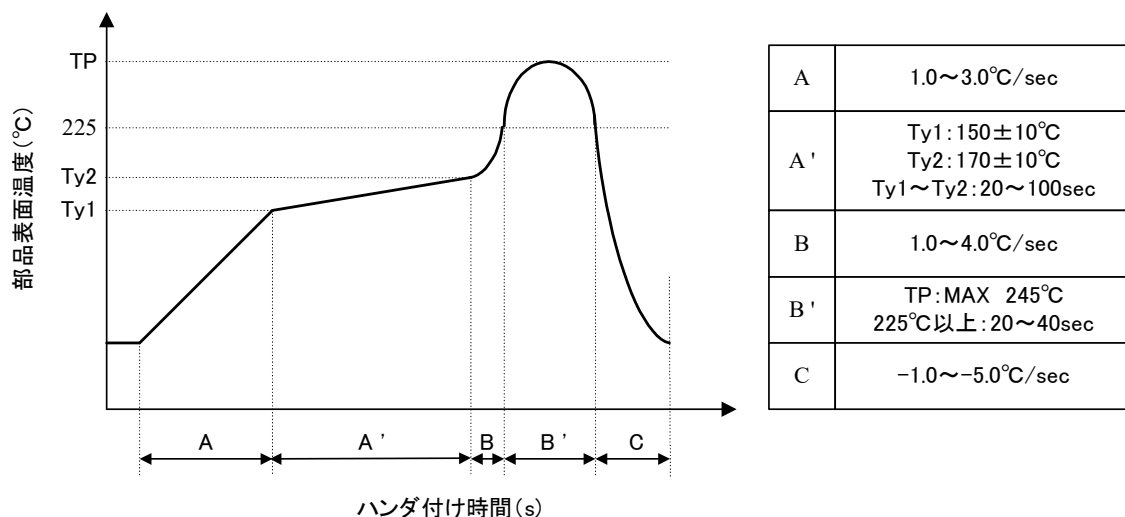

Fig. 5-1 Reflow Process Conditions for SMD Models

### 5-2 Washing Conditions

We do not recommend board cleaning after soldering, we recommend not performing cleaning, but when cleaning becomes necessary, perform it according to the conditions shown in Table 5-2

Table 5-2 Cleaning Fluid and Test Conditions

Cleaning Fluid	Cleaning Method	Time
Isopropyl Alcohol	Ultrasonic Wave 60°C	60 sec.
	Cold Bath Cleaning R.T	60 sec.
	Vapor Cleaning 83°C	60 sec.

※Contact TDK-Lambda concerning items not mentioned or items which are not clear.

5-3 Installation Method

When installing the converter on the board, avoid having trace pattern, etc. in the slanted line area shown in Figure 5-3 because there is the possibility of an insulation defect occurring.

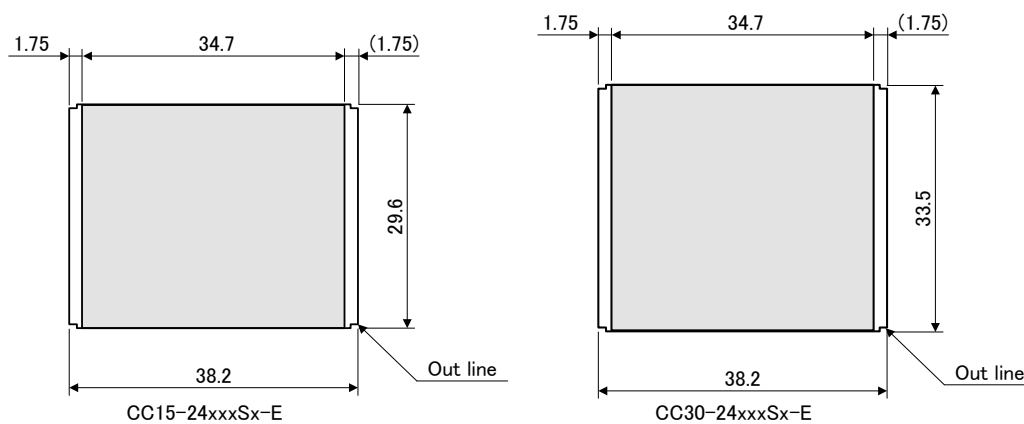

Fig. 5-3 Trace Pattern Prohibited Area