



DLP-PU/EJ

Instruction Manual

BEFORE USING THE POWER SUPPLY UNIT

Pay attention to all warnings and cautions before using the unit. Incorrect usage could lead to an electrical shock, damage to the unit or a fire hazard.



- **Warning Symbols**

CAUTION	
<ul style="list-style-type: none"> • OPERATION TEMP RANGE -10---+60 °C (100% LOAD) +70 °C (60% LOAD) SEE INSTRUCTION MANUAL 	
<ul style="list-style-type: none"> • DO NOT MODIFY, DISASSEMBLE THE POWER SUPPLY. 	
<ul style="list-style-type: none"> • INSTALLATION BY TRAINED PERSONAL ONLY. 	

NOTICE:

(1) Installing/Storage Environment

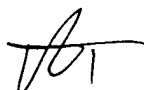
1. Store the product with ambient temperature -30 to +85 °C, and relative humidity 10 to 95% (No Dewdrop).
2. Never operate the unit under over current or shorted conditions for 30 seconds or more and out of Input Voltage Range in specification which could result in damage or insulation failure or smoking or burning.
3. Confirm connections to input/output terminals are correct as indicated in the instruction manual.
4. Use the product where the relative humidity is 30 to 90% (No Dewdrop).
5. Avoid places where the product is subjected to direct sun light.
6. Avoid penetration of metal chips when processing mounting holes.

DWG NO. : CA738-04-01/EJ-A		
APPD	CHK	DWG
 29. Jun. 2004	 25/ Jun / 2004	 23/ Jun / 04

7. Avoid places where the products is subjected to penetration of liquid, foreign substance, or corrosive gas.
8. Avoid places subject to shock or vibration.
 A device such as a contact breaker may be a vibration source. Set the product as far as possible from possible sources of shock or vibration.
9. If the product is used in an area with excessive electronic noise, be sure to separate the unit as far as possible from the noise sources.

Precautions in Using the product:

When the product is used under the circumstance or environment below, ensure adherence to limitations of the ratings and functions.

Also take countermeasures for safety precautions such as fail-safe installations.

1. Under the circumstances or environment which are not described in the instruction manual.
2. For nuclear power control, railway, aircraft, vehicle, incinerator, medical equipment, entertainment equipment, safety device etc...
3. For applications where death or serious property damage is possible and extensive safety precautions are required.
4. Don't recommend using input power source with large inductance, which may cause unit operate unstably.
5. The end equipment manufacturer must provide protection to service personal against inadvertent contact with terminals.
 These terminals must not be user accessible.
6. Ensure power supply with over current protection (less than 24A) function.

1. Terminal Explanation

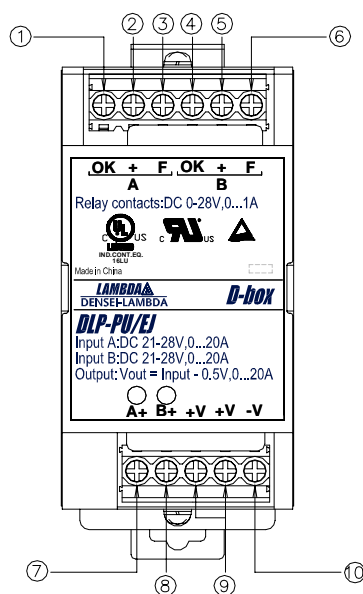

- ① OK: OK signal terminal of relay A
- ② +: + Signal terminal of relay A (relay A common)
- ③ F: F signal terminal of relay A
- ④ OK: OK signal terminal of relay B
- ⑤ +: + Signal terminal of relay B (relay B common)
- ⑥ F: F signal terminal of relay B
- ⑦ A+: DC input + of channel A
- ⑧ B+: DC input + of channel B
- ⑨ +V: Output terminal +
- ⑩ -V: Ground of both input voltage and output voltage

2. Terminal Connecting Method

Pay attention to the input wiring. If it is connected to wrong terminal, the unit may be damaged.

- Input must be off when making connections.
- Connect ground of input channel A, input channel B and output together to -V terminal.

When connecting or removing input and output wire, do not apply stress to PCB.

3. Explanation of Functions and Precautions

3-1. Simplified DLP-PU/EJ connection block

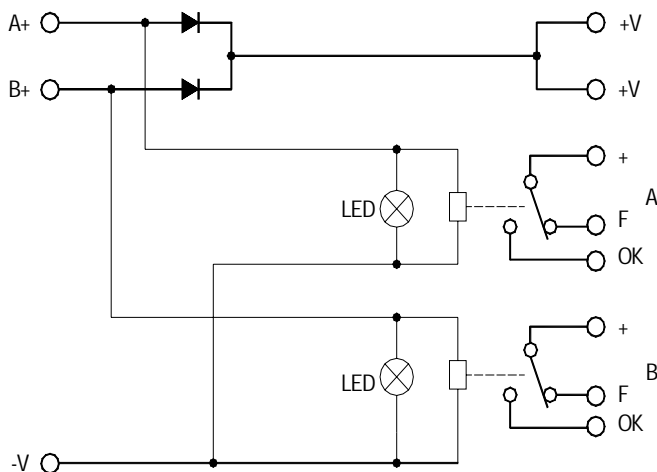

3-2. Input Voltage Range

Nominal input voltage range is 21 ~ 28VDC. Input voltage above 35VDC (continuous), or reverse output voltage more than 35VDC may cause unit damage.

3-3. Output Voltage Range

Output voltage is the higher input voltage of both channels decrease 0.5VDC (output drop voltage).

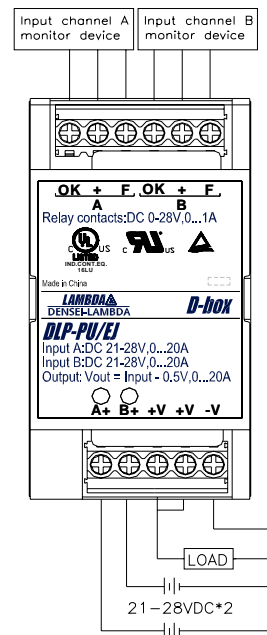

3-4. Nominal Input Current and Maximum Output Current

Nominal input current is 20A (A,B total), maximum output current is 20A.

3-5. Input Voltage Supervision

Each channel is supervised. For voltages above low input voltage alarm level (19.2VDC±1%), a relay is activated closing a galvanically free contact, + to OK (Normally Open, NO). For voltages above high input voltage alarm level (30VDC±5%) a relay is activated closing a galvanically free contact, + to F. The relay also has a Normally Closed, NC contact set, eg. + to F (Fail).

This voting device also is equipped with green Light Emitting Diodes, lighting simultaneously with the respective activated relay. LED lights when input voltage within input voltage range, goes off when input voltage below low input voltage alarm level or above high input voltage alarm level.

3-6. Supervision Built-in Relay Specification

Maximum relay contacts ratings is 28VDC, 1A. Minimum relay contacts ratings is DC 1mA (5mA or more recommended). The relay outputs need maximum 4A over current protection.

3-7. Operation Schematic

Fig. A Dual Input Mode

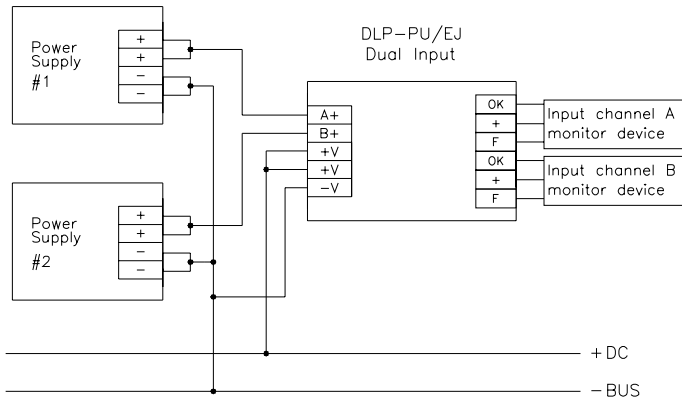

3-9. Withstand Voltage

This model is designed to withstand 500VAC between input, output and FG (Chassis), input, output and relay contact, relay contact and FG each for 1 minute. When testing withstand voltage, set current limit of the withstand voltage test equipment to 100mA. The applied voltage must be gradually increased from zero to the testing value and then gradually decreased for shut down. When timer is used, the

power supply may be damaged by high impulse voltage at timer switch on and off. (Ref. to Fig C)

- ① Input,Output ~ FG(Chassis) -- 500VAC 100mA or more
- ② Input,Output ~ Relay Contact --500VAC 100mA or more
- ③ Relay Contact ~ FG(Chassis) -- 500VAC 100mA or more

Note: please use the same model power supplies (#1 and #2) in conformance with UL508 safety requirement.

Fig. B Single Input Mode

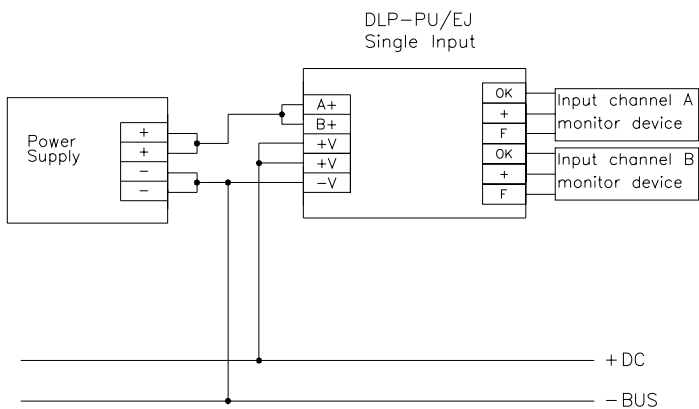

3-8. Isolation Test

Isolation resistance shall be more than 10MΩ at 500VDC for safety operation, voltage setting of DC isolation tester must be done before the test. Ensure that it is fully discharged after the test. (Ref. to Fig C)

- ① Input,Output ~ FG(Chassis) -- 500VDC 10MΩ or more
- ② Input,Output ~ Relay Contact --500VDC 10MΩ or more
- ③ Relay Contact ~ FG(Chassis) -- 500VDC 10MΩ or more

Fig. C Test Method

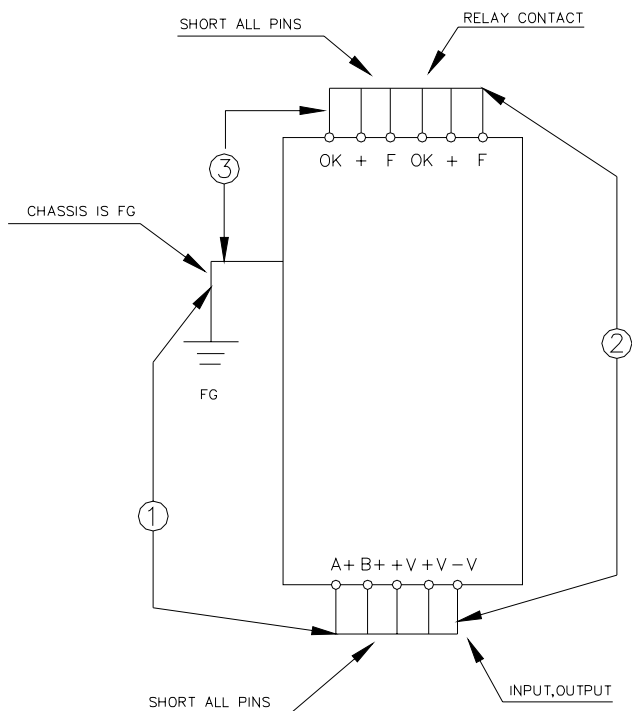

4. Mounting Directions

4-1. Output Derating according to the Mounting Directions

Recommended standard mounting method is (A). Please do not use installation method (B). Refer to the derating below. Do not exceed the load deratings.

Normal mounting (A)

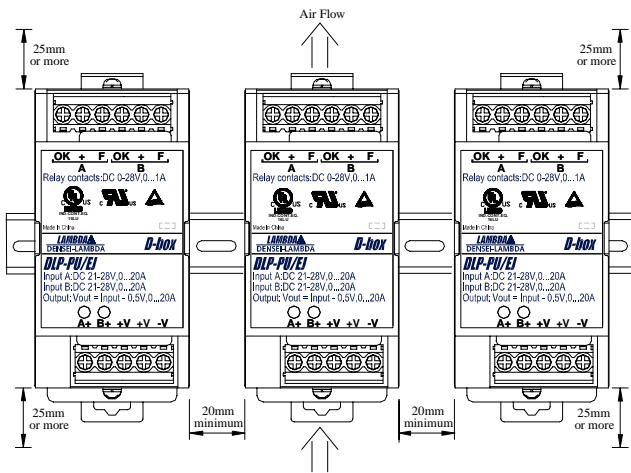

Back Down Mounting (B)

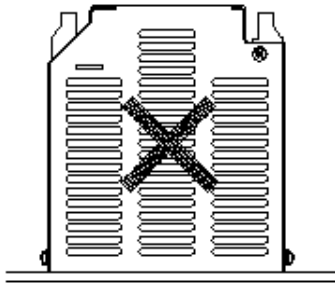

Output Derating (100% load = 20A)

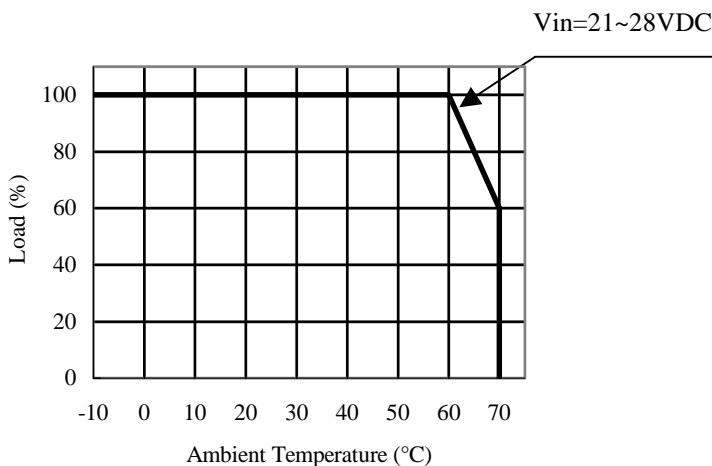

5. Wiring Method

- The output load line and input line shall be separated and twisted to improve noise sensitivity.
- Use all lines as thick and short as possible to make lower impedance.
- Noise can be eliminated by attaching a capacitor to the load terminals.
- Recommended screw torque is 0.49 N.m (5kg.cm).
- Recommended wire type: solid and stranded single wire, AWG 12~20 (wire strip length: 7mm).
- Below appropriate over current protection is required when make connection

Over current protection rating is based on the smallest wire connection to either the input or output		
Wire size (AWG)	Wire size (mm ²)	Maximum over current protection rating (A)
20	0.52	5
18	0.82	7
16	1.3	10
14	2.1	20
12	3.3	25

6-1. Power supply mounting on DIN RAIL (TS35 or equivalent)

- (1) Tilt the unit slightly rearwards, fit the unit over top hat rail.

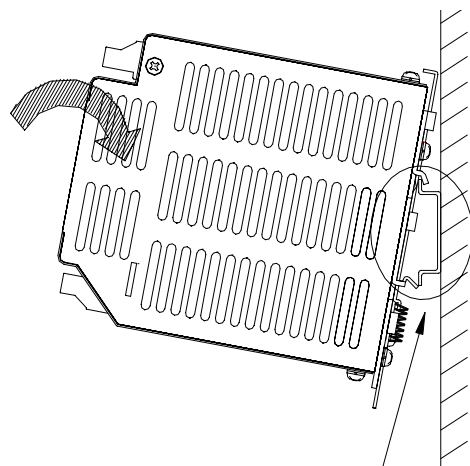

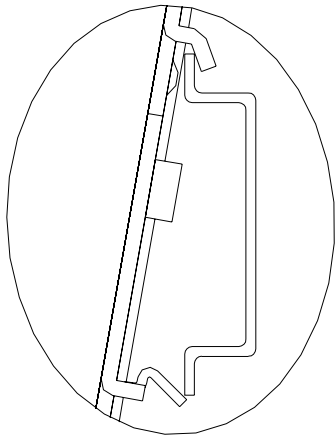

- (4) In order to tighten the unit mounting, the Din rail stopper attached on both sides of the unit is recommended.

6-2. Power supply removal from DIN RAIL

- (1) Switch main power off and disconnect your system from the supply network. Push the button on the rear upper edge of the unit or move the removal hole on the rear down edge downwards by screw driver. Gently lift lower front edge of the unit (tipping) and remove it.

- (2) Slide it downward until it hits the stop.

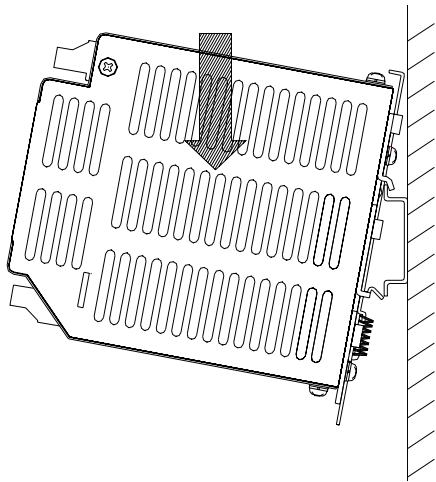

- (3) Press against the bottom front side for locking.
Shake the unit slightly to check the locking action.

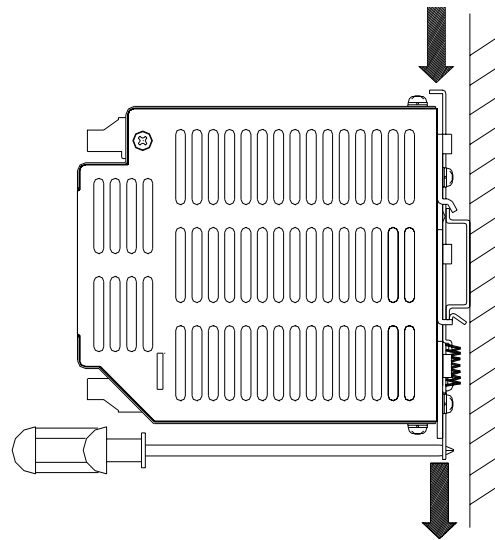
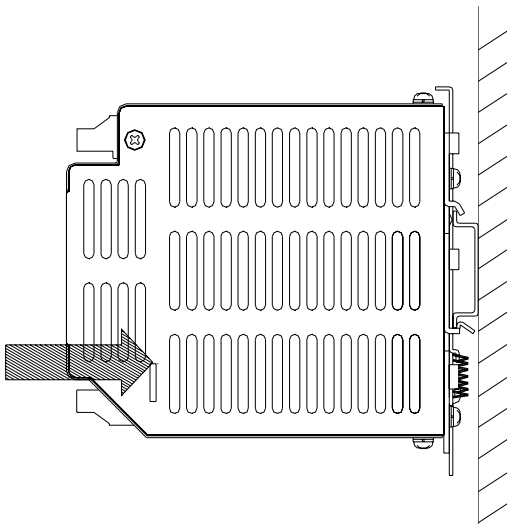

7. Before concluding that the unit is at fault...

Before concluding that the unit is at fault, make the following checks.

- Check if the rated input voltage is connected.
- Check if the wiring of input and output is correct.
- Check if the wire material is not too thin.
- Check if the output current and output wattage do not over specification.

8. Notes

- 1) Meet EN50178 over voltage Category I.
- 2) Radio Interference Suppression Test is not performed.

9. Repair

**In case of damage or repair of this product,
please return to our service center or factory.**