

# *HWS300 · 600 Series*

## *Instruction Manual*

### **BEFORE USING THE POWER SUPPLY UNIT**

Be sure to read the following precautions thoroughly before using this power supply unit.

Pay attention to all warnings and cautions before using the unit. Incorrect usage could lead to an electrical shock, damage or a fire hazard.

#### **⚠ WARNING**

- Do not make unauthorized changes to power supply unit, otherwise you may have electric shock and void warranty.
- Do not touch the internal components, they may have high voltage or high temperature. You may get electrical shock or burned.
- When the unit is operating, keep your hands and face away from it; an accident may injure you.
- Do not use unit under unusual condition such as emission of smoke or abnormal smell and sound etc. It might cause fire and electric shock.

In such case, please contact us; do not repair by yourself, as it is dangerous for the user.

- Do not drop or insert anything into unit. It might cause failure and fire, when using the unit under such condition.
- Do not operate these units at the condition of condensation. It may cause fire and electric shock.
- The outputs of these products must be earthed in the end use equipment to maintain SELV.

If the outputs are not earthed, they must be considered hazardous and must not be made user accessible.

#### **⚠ CAUTION**

- This power supply is primarily designed and manufactured to use and enclose in other equipment.
- This power supply unit has a built-in fan for air-cooling. Do not block air intake and exhaust. It might cause fire.
- Input voltage, Output current, Output power, ambient temperature and ambient humidity should be within specifications, otherwise the unit will be damaged.
- The unit might be broken down by accident or unexpected situation. For application equipment, which requires very high reliability (nuclear related equipment, traffic control equipment, medical equipment, etc.), please provide fail safety function in the equipment.
- Do not make an improper wiring to input and output terminals. It may cause damage.
- Do not use in environment such as strong electromagnetic field, erosive gas etc, or any environment where conductive foreign substance may enter.
- Do not operate and store this unit at the condition of condensation. In such case, waterproof treatment is necessary.
- Do not operate this unit after it falls down.
- The output voltage of this power supply is considered to be a hazardous energy level, and must not be accessible to an operator.

## 1. Model name identification method

**HWS 300 – 5 / □**

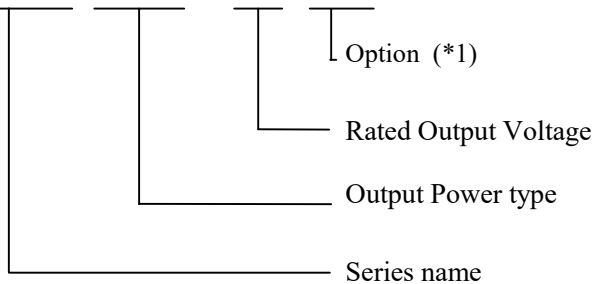

(\*1)

/ “No assigned” : Standard type

/PV : Output voltage can be controlled by external voltage.

(Only 12 – 48V output model)

## 2. Terminal Explanation

Please pay extra attention to the wiring. Incorrect connection will damage the power supply.

### 2-1. Front Panel Explanation

#### HWS300

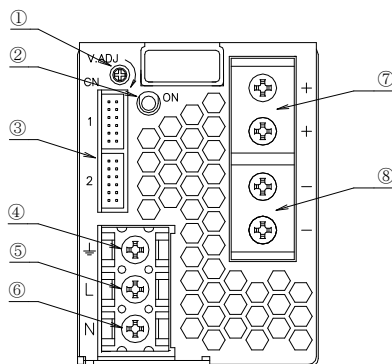

#### HWS600

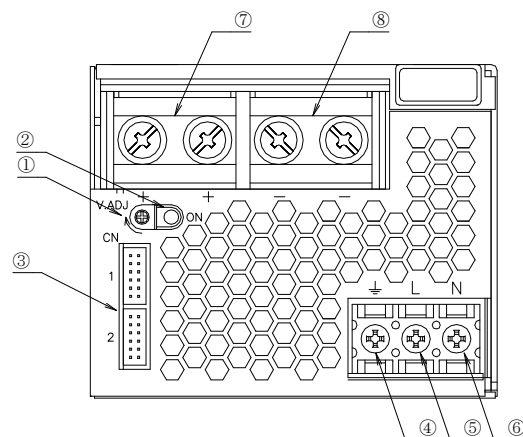

- ① V.ADJ : Output voltage adjustment trimmer.  
(The output voltage rises when a trimmer is turned clockwise.)
- ② ON : Output (Power On) indication LED  
(The indicator turns on when the power supply output is in normal operating condition.)
- ③ CN1, CN2 : Remote sensing, ON/OFF control signal, Current balance signal, Power fail signal,  
Output voltage external control signal. (Refer to 2-2.)
- ④  $\perp$  : Protective Earth (Frame ground), M4 screw.
- ⑤ AC input terminal L : Live Line (Fuse in line), M4 screw.
- ⑥ AC input terminal N : Neutral line, M4 screw.
- ⑦ + : + Output terminal  
(HWS300: M4 screw x 2 / HWS600: M5 screw x 2)
- ⑧ - : - Output terminal  
(HWS300: M4 screw x 2 / HWS600: M5 screw x 2)

## 2-2. CN1, CN2 Connector pin Configuration and Function

CN1 and CN2 are same pin configuration and function.

They are connected to each other in this power supply unit.

When the pin of CN1 side is shorted, the same function pins of CN2 side are also shorted.

Please note that the function cannot be separately set with CN1 and CN2.

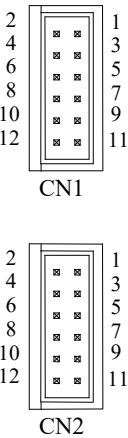
	Pin No.	Configuration	Function
	1	+Vm	+Output monitor terminal. Connected to +Output terminal in this Power supply unit. ( +Vm terminal cannot supply load current. )
	2	+S	Remote sensing terminal for +output. (For remote sensing function, which compensates for line drop between power supply terminals and load terminals. Connect to +Vm terminal when remote sensing function unnecessary. )
	3	-Vm	-Output monitor terminal. Connected to -Output terminal in this Power supply unit. ( -Vm terminal cannot supply load current. )
	4	-S	Remote sensing terminal for -output. (For remote sensing function, which compensates for line drop between power supply terminals and load terminals. Connect to -Vm terminal when remote sensing function unnecessary. )
	5	PC	Current balance terminal. ( For output current balancing in parallel operation. )
	6	COM	GND for PC and PV signals.
	7	PV ( Optional )	Output voltage external control terminal. ( For power supply output voltage control with an external voltage. Standard Model don't have this function and indicate NC mark at panel.
	8	NC	No connect
	9	CNT	Remote ON/OFF control terminal. ( Power supply ON/OFF control with an external signal. )
	10	TOG	GND for CNT and PF signals. ( Same as Pin No.12 )
	11	PF	Power fail signal (PF signal) output terminal. ( As the output voltage drops, or FAN stops and AC input voltage down, "Power Fail" terminal will output "High".
	12	TOG	GND for CNT and PF signals. ( Same as Pin No.10 )

### CN1, CN2 Connector & Housing & Terminal Pin

PART DESCRIPTION	PART NAME	MANUFACT
PIN HEADER	S12B-PHDSS	JST
SOCKET HOUSING	PHDR-12VS	JST
TERMINAL PINS	SPHD-002T-P0.5(AWG28~24) SPHD-001T-P0.5(AWG26~22)	JST
HAND CRIMPING TOOL	YRS-620(SPHD-002T-P0.5) YC-610R(SPHD-001T-P0.5)	JST

### 3. Terminal Connection Method

Please pay extra attention to the wiring. Incorrect connection will damage the power supply.

- When connecting input and output wiring, and CN1, CN2, input AC-Line should be off.
- Input wiring and output wiring shall be separated to improve noise sensibility.
- The protective earth (PE) must be connected to the  $\perp$  terminal or chassis.
- Remote sensing lines shall be twisted or used shielded wires.
- Remote ON/OFF control lines shall be twisted or used shielded wires. Separate from load line.
- Output current of each terminal screw shall be less than 40A for HWS300. And shall be less than 60A for HWS600.

#### HWS300 Panel Side (Common HWS600)

##### • Basic connection (Local sensing)

Connect “+S” terminal to “+Vm” terminal and “-S” terminal to “-Vm” terminal. Connect “CNT” terminal to “TOG” terminal with the attached connector.

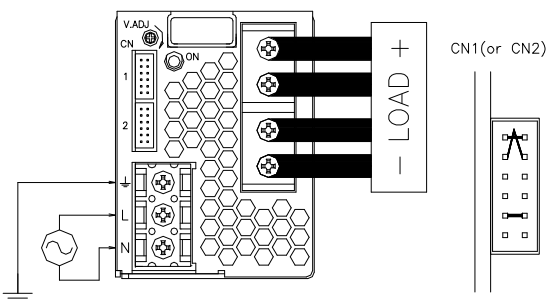

##### • Remote sensing required

Connect “+S” terminal to “+” terminal of load and “-S” terminal to “-” output terminal of load with wires.

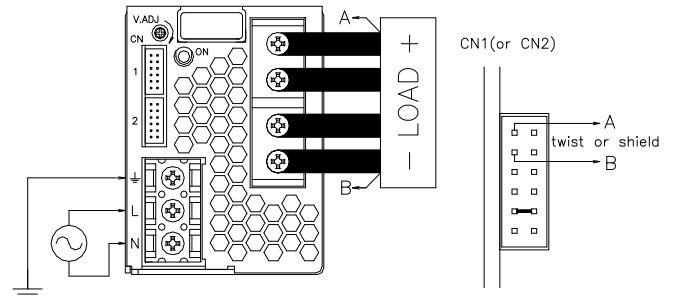

##### • ON/OFF control required

“TOG” terminal is ground for “CNT” terminal.

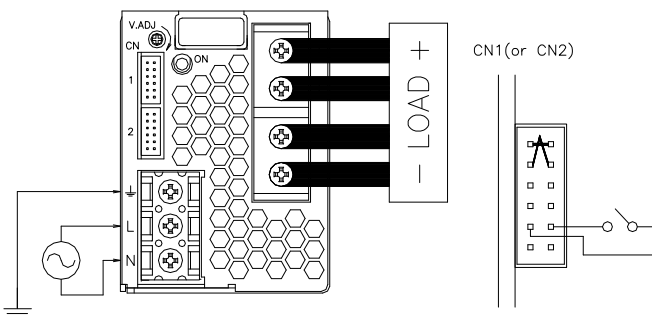

##### • PF signal output required

Open collector method shown below shall be used. “TOG” terminal is ground for “PF” terminal.

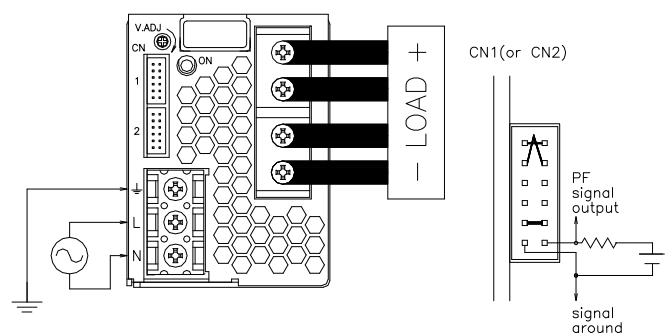

## 4. Functions and Precautions

### 4-1. Input Voltage Range

Input voltage range is single phase 85 ~ 265VAC (47 ~ 63Hz) or 120 ~ 330VDC. Input voltage, which is out of specification, may cause unit damage. Rated input voltage for safety standard application is 100AC-240VAC(50/60Hz).

### 4-2. Output Voltage Range

Output voltage is set to the rated value at shipment. V.ADJ trimmer on the front panel side is may be used to adjust the output voltage within the range specified.

Output voltage range is within  $\pm 20\%$  of rated output voltage (48V Output Model :  $-20\% \sim +10\%$ ).

To turn the trimmer clockwise, the output voltage will be increased. Take note when the output voltage is increased excessively, over voltage protection (OVP) function may trigger and output voltage will be shut down.

### 4-3. Over Voltage Protection (OVP)

The OVP function (Inverter shutdown method, manual reset type) is provided. OVP function operates within 125-145% of the rated output voltage value (48V type: 115-135%), and the output will be shut down when OVP function triggers.

To reset OVP, remove the input of power supply for a few minutes, and then re-input. Or, use CNT reset ( remote ON/OFF : OFF to ON). OVP value is fixed and not to be adjusted externally.

Never apply more than rated output voltage to output terminal, which may leads damage. In the case of inductive load, use decoupling diode at output line.

### 4-4. Over Current Protection (OCP)

The OCP function is provided. OCP characteristic is constant current limiting, (less than 5V output model: with Hiccup operation) automatic recovery. OCP function operates when the output current exceeds 105%(24V output model: 119%) of maximum DC output current specification. The output will be automatically recovered when the overload condition is canceled. Never operate the unit under over current or shorted conditions for more than 30 seconds, which may leads damage. OCP setting is fixed and not to be adjusted externally.

### 4-5. Over Temperature Protection (OTP)

The OTP function (manual reset type) is provided. When ambient or internal temperature rises abnormally, OTP function operates and output will be shut down. After shut down, remove the input and cool it down to reset OTP. Then re-input.

### 4-6. Low Output Detection Circuit (PF)

Low output voltage detection circuit is provided. Power Fail (PF) signal will turn "High" level to indicate the abnormal status when the output voltage becomes within 65 ~ 80% of rated value caused by either the drop or brownout of the input voltage or OCP, OVP and OTP function operation. When the built-in FAN motor of this power supply unit stops, PF signal will turn to "H". The PF signal is isolated from input and output by a photo-coupler. It uses the open collector method shown in below.

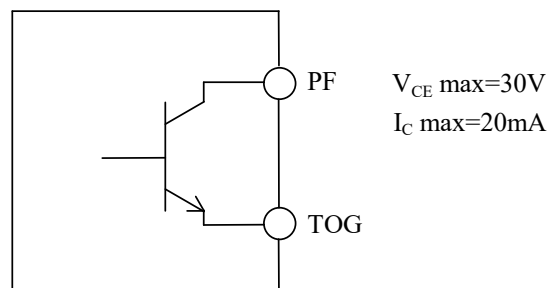

#### 4-7. Remote Sensing (+S, -S terminal)

This function compensates voltage drop of wiring from output terminals to load terminals. Connect “+S” terminal to “+” terminal of load and “-S” terminal to “-” terminal of load with sensing wires. The total line voltage drop (+ side line and - side line) shall be less than 0.3V. In case that sensing lines are too long, it is necessary to put an electrolytic capacitor in following 3 places;

- 1) across the load terminal,
- 2) between “+S” terminal and “+” terminal,
- 3) between “-S” terminal and “-” terminal.

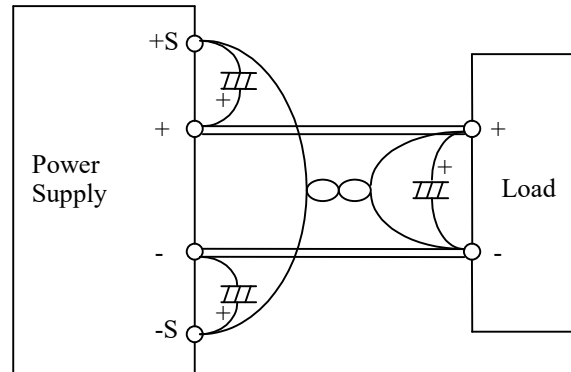

When the function of remote sensing is not in used, connect +S terminal to +Vm terminal, and -S terminal to -Vm terminal by the attachment connector.

If remote sensing terminals are opened, the stability and the accuracy of the output deteriorated. Therefore, terminal +S, -S must be connected.

#### 4-8. Remote ON/OFF Control

Remote ON/OFF control is provided.

Using this function, output on/off is allowed to control without input voltage on/off. The output is turned to ON when TOG and CNT terminals are shorted, and the output is turned to OFF when these terminals are opened. When the function is not used, connect TOG and CNT terminals. The standards for this function are as follows. “TOG” terminal is return for “CNT” terminal.

- (1) TTL compatible. The maximum input voltage to CNT terminal is 12V, and the maximum allowable reverse voltage is -1V. The sink current for CNT terminal is 3.5mA.
- (2) A switch and relay or a transistor can be used as ON/OFF switch.
- (3) Remote ON/OFF control circuit is isolated from the input and output by a photo-coupler and can be controlled regardless of the output potential (+ or -). Connect TOG terminal to ground of control signal.

#### The mode of control

CNT Level for TOG Terminal	Output	Built-in Fan
Short or L (0V - 0.8V)	ON	Rotate
Open or H (2.4V - 12V)	OFF	Stop

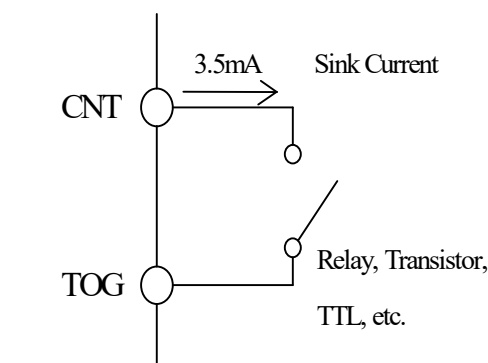

#### 4-9. Output Ripple & Noise

The standard specification for maximum ripple value is measured specified measurement circuit (JEITA-RC9131A). When load lines are longer, ripple becomes larger. In this case, electrolytic capacitor, film capacitor, etc. might be necessary to use across the load terminal. The output ripple cannot be measure accurately if the probe ground lead of oscilloscope is too long.

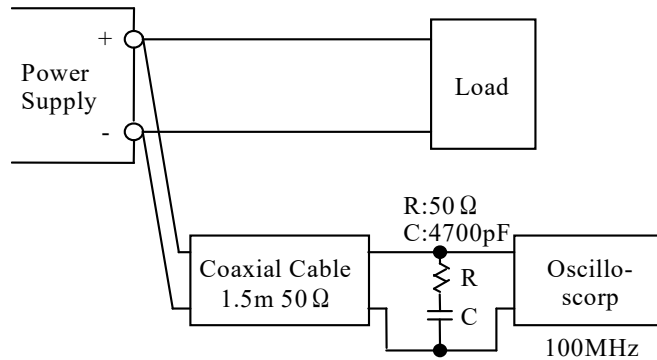

#### 4-10. Series Operation

For series operation, both method (A) and (B) are possible. There might be a step in the output rise waveform during series operation.

Method (A)

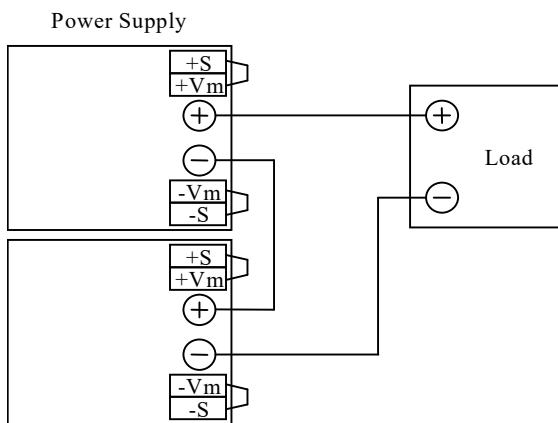

Method (B)

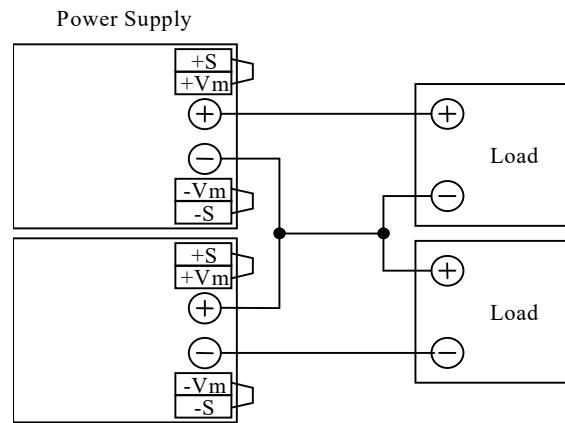

#### 4-11. Parallel Operation

Current balancing function is provided. Both operations mode (A) and (B) are possible.

##### (A) To Increase the Output Current

Connecting PC to PC terminal and COM to COM terminal, the current balancing function activates and output current of each power supply is equivalently supplied to load. Wires to PC terminals, COM terminals shall be as short as possible and same length and twisted.

There is a possibility that output could be unstable caused by external noise. For this case, disconnect COM terminal and connect -S terminal from parallel power supply to a single point on the load. Please refer connection Method (A)-2.

1. Adjust the output voltage of each power supply to be same value within 1% or 100mV whichever is smaller.
2. Use same length and type of wires for all load lines.
3. Use the power supply within the rated output current for all paralleled models.
4. Parallel operation is possible up to 5 units.

##### (B) To Use as a Backup Power Supply

1. Adjust the output voltage of each power supply to be same value.
2. Set power supply output voltage higher by the forward voltage drop of diode.
3. Use within the specifications for output voltage and output current.

Method (A)

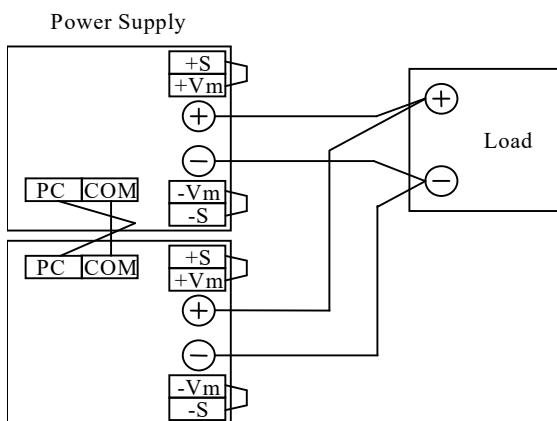

Method (A)-2

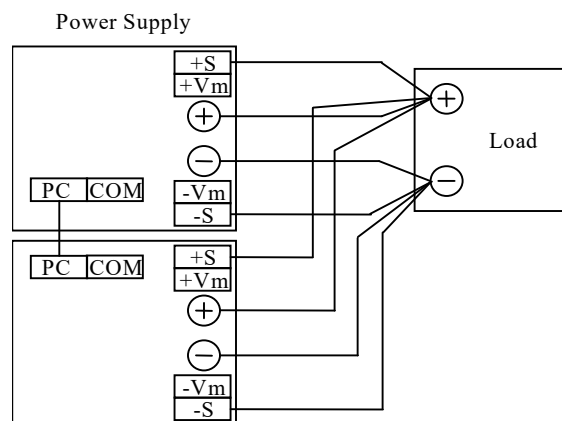

Method (B)

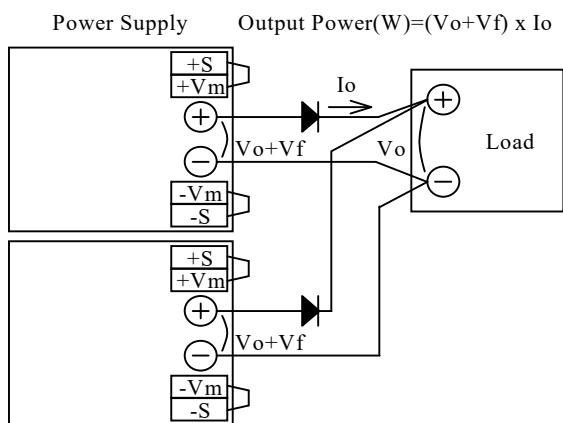



**4-12. Isolation Test**

Isolation resistance between output and  $\perp$  (chassis) shall be more than 100M $\Omega$  at 500VDC and between output and CNT·PF shall be more than 10M $\Omega$  at 100VDC. For safety operation, voltage setting of DC isolation tester must be done before the test. Ensure that it is fully discharged after the test.

Output ~ FG (chassis) : 500VDC 100M $\Omega$  or more

Output ~ CNT · PF : 100VDC 10M $\Omega$  or more

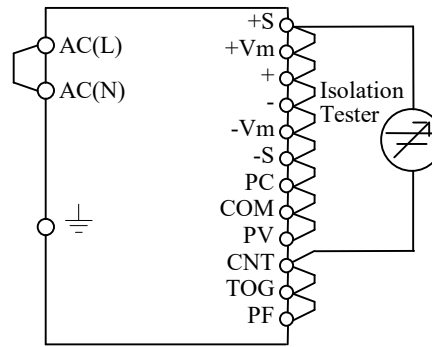
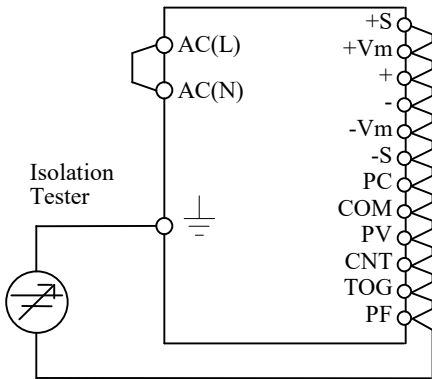

**4-13. Withstand Voltage**

This series is designed to withstand 3.0kVAC between input and output, 2.5kVAC between input and  $\perp$  (chassis), 500VAC between output and  $\perp$  (chassis), and 100VAC between output and CNT·PF terminal each for 1 minute. When testing withstand voltage, set current limit of withstand voltage test equipment at 20mA.

(Output- $\perp$  (chassis) and Output-Control: 100mA).

The applied voltage must be gradually increased from zero to testing value and then gradually decreased for shut down. When timer is used, the power supply may be damaged by high impulse voltage at timer switch on and off. Connect input and output as follows.

Input ~ Output (dotted line) : 3.0kVAC 1min. (20mA)

Input ~  $\perp$  (chassis) (solid line) : 2.5kVAC 1min. (20mA)

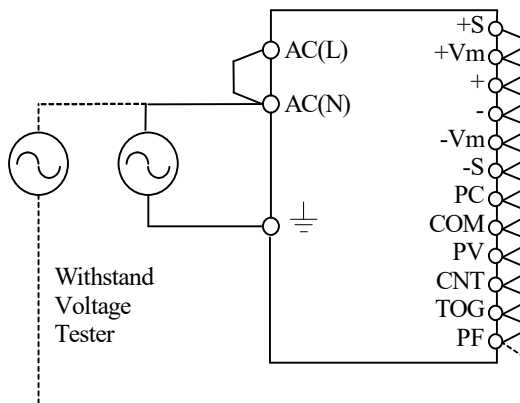

Output ~  $\perp$  (chassis) : 500VAC 1min. (100mA)

Output ~ CNT·PF : 100VAC 1min. (100mA)

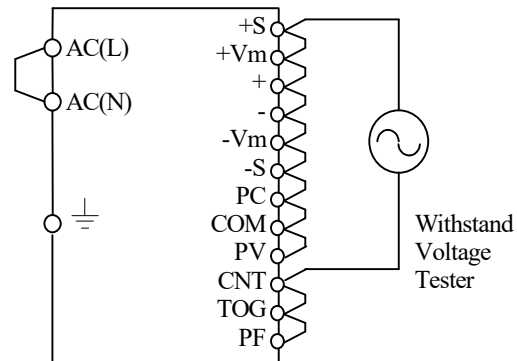
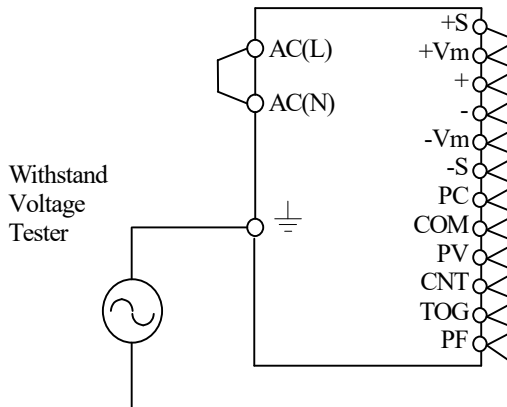

\*This product have monolithic ceramic capacitor in secondary circuit to frame ground.

Some of the withstand voltage tester may generate high voltage at the matching with monolithic ceramic capacitor and may cause the unit damage.

So, please check the waveform of test voltage.

#### 4-14. Output Voltage External Control (PV)

Output voltage external control function is available as option with model name followed by “/PV”. Output voltage can be varied by applying an external voltage (1 – 6v) to “PV” terminal and “COM” terminal. Note if an external voltage is not applied, there will be no output. Please consider the following characteristics.

Connection method

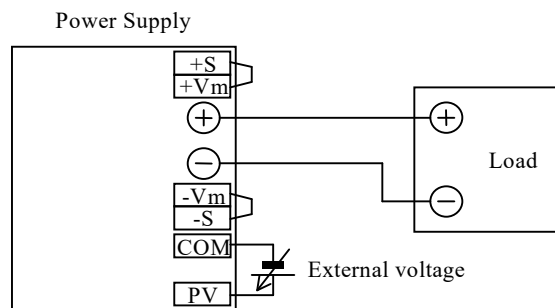

#### Output Voltage Linearity

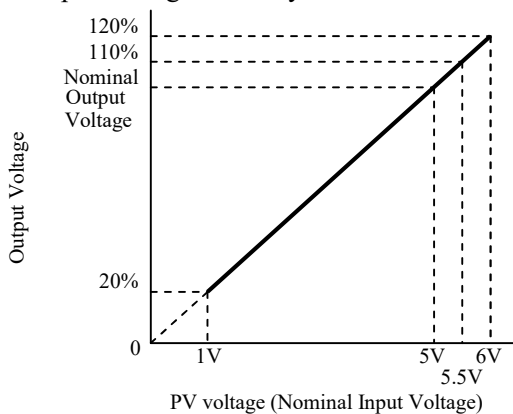

#### Output Voltage Derating

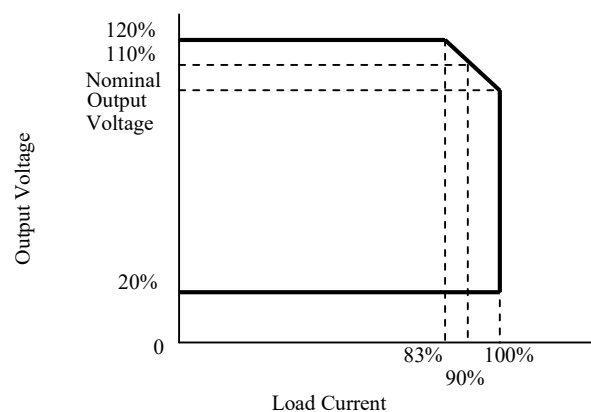

Note 1. Regarding output voltage adjustment below 20%, please consult our sales.

Note 2. For 48V output model only, spaces below must be followed. Limit output voltage variation range at 20% ~ 110%.  
 At PV voltage variation 1V ~ 5.5V.

#### 4-15. Output Peak Current

For 24V output model, please meet the following condition. Reduce peak current value according to output derating as section 5-1.

- Input Voltage range : AC180V~265V
- Continuous Peak output time (  $\tau$  ) : Within 10 seconds
- Peak output current (  $I_p$  ) : Within the rated peak output current
- Average DC output current (  $I_m$  ) : Within the rated output current

$$I_m = \frac{(I_p - a) \times \tau}{T} + a \leq I_{av}$$

Duty : up to 35(%)

$$\text{Duty} = \frac{\tau}{T} \times 100 (\%)$$

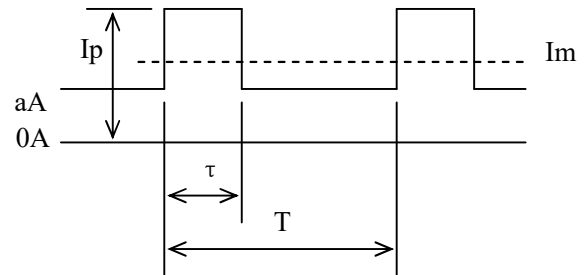

- $I_p$  : Peak output current (A)
- $I_{av}$  : Rated output current (A)
- $I_m$  : Average output current (A)
- $\tau$  : Peak current pulse width (sec)
- $T$  : Period (sec)

### 5. Mounting Directions

#### 5-1. Output Derating according to the Mounting Directions.

Recommended standard mounting method is (A). Method (B) is also possible. Refer to the derating below.

HWS300

(A) Standard Mounting

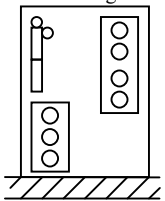

(B)

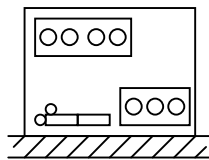

(C) Inhibit

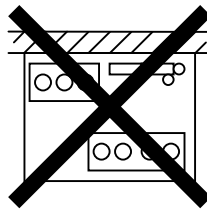

(D) Inhibit

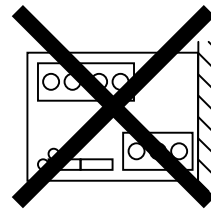

HWS600

(A) Standard Mounting

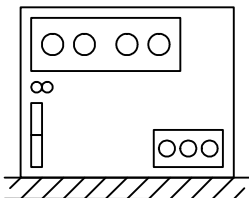

(B)

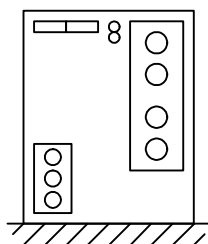

(C) Inhibit

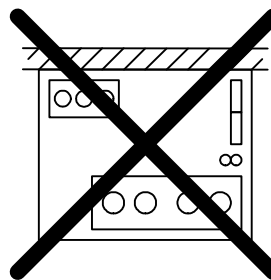

(D) Inhibit

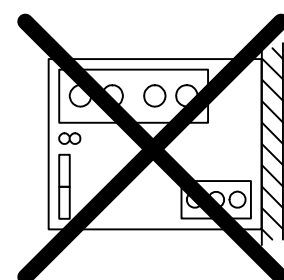

## 5-2. Output Derating

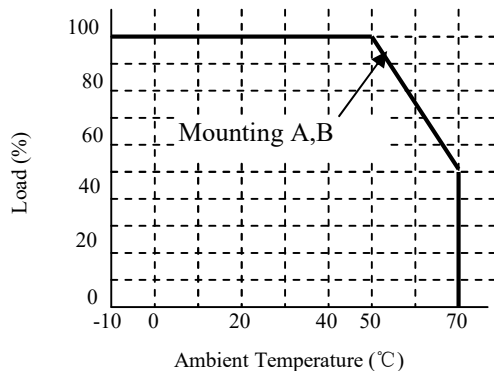

Ta(°C)	Load (%)	
	Mounting(A)	Mounting(B)
-10 ~ +50	100	
+70	50	

## 5-3. Mounting Method

- Forced cooling type power supply.  
 This power supply has ventilating holes on the front and back side panels. Keep these two areas freely as much as possible.
- The maximum allowable penetration is 6mm.  
 Incomplete thread of mounting screw should not be penetrated.
- Recommended torque for mounting screw :  
 M4 screw : 1.27 N · m ( 13.0kgf · cm )

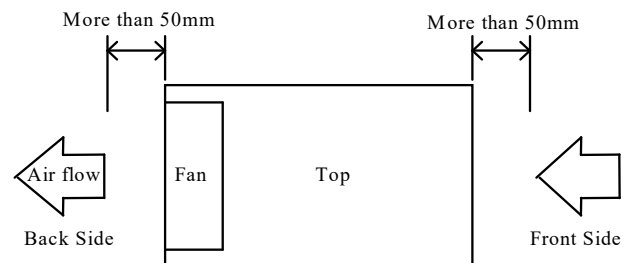

## 6. Wiring Method

- The output load line and input line shall be separated to improve noise sensitivity.
- The sensing lines shall be twisted and separated from the output lines for remote sensing.
- Use all lines as thick and short as possible to make lower impedance.
- Attaching a capacitor to the load terminals can eliminate noise.
- For safety and EMI considerations, connect  $\perp$  terminal to the mounting set ground terminal.
- Recommended torque for the terminal ;  
 HWS600 Output terminal (M5 screw) : 2.50 N · m (25.5kgf · cm )  
 HWS300 Input, Output terminal & HWS600 Input terminal (M4 screw) : 1.27 N · m (13.0kgf · cm )

### [ The PHD connector manufacture method ]

This product is using SPHD-001T-P0.5 or SPHD-002T-0.5 connector made from JAPAN SOLDERLESS TERMINAL MFG CO LTD.

Regarding to manufacture of a connector, it becomes the regulation as following.

#### a). Applicable Wire and Crimping tool

Wire size is AWG#26 ~ AWG#22 and insulation outer dia is  $\phi$  1.0 ~  $\phi$  1.5 mm.  
 Appreciable wire per barrel size is UL1007 (standard wire ) and its equivalent standard wire can be used.  
 Regarding the AWG#22, use UL1061 or its equivalent standard wire, because wire insulation outer diameter of UL1061 is samll.  
 Crimping tool is as below.

Crimping tool	Crimping applicator	Dies
AP-K2 or AP-KS	MKS-LS-10 or MKS-L-10	SPHD-001-05/SPHD-002-05

**b). Crimping Operation**

The reference value of wire strip is 2.3mm. As wire strip length differs depending on type of wire and crimping method, decide the best wire strip length considering processing condition. When wire is stripped, do not damage or cut off wire conductores.

Table of crimp height  
 SPHD-001T-P0.5

Wire		Insulation O.D (mm)	Crimp height (mm)	
Type	Size		Conductor part	Insulation part
UL1007	AWG #26	1.3	0.60 ~ 0.70	1.7
UL1007	AWG #24	1.5	0.65 ~ 0.75	1.8
UL1061	AWG #22	1.4	0.70 ~ 0.80	1.8

SPHD-002T-P0.5

Wire		Insulation O.D (mm)	Crimp height (mm)	
Type	Size		Conductor part	Insulation part
UL1007	AWG #28	1.2	0.55 ~ 0.60	1.6
UL1007	AWG #26	1.3	0.60 ~ 0.65	1.7
UL1007	AWG #24	1.5	0.62 ~ 0.67	1.8

Note 1. Crimp height at wire barrel should be set to pre-determined dimensions.

Note 2. Adjust crimp height at wire insulation barrel to the extent that wire insulation is slightly pressed, and set it so that crimping is not excessivery.

Note 3. Crimping condition at wire insulation barrel is as below Fig.1.

Note 4. For AWG#28,#26,#24, use UL1007 type. For AWG#22, use UL1061 type.

Fig.1



Good

Fig.2: Examples of defective crimping

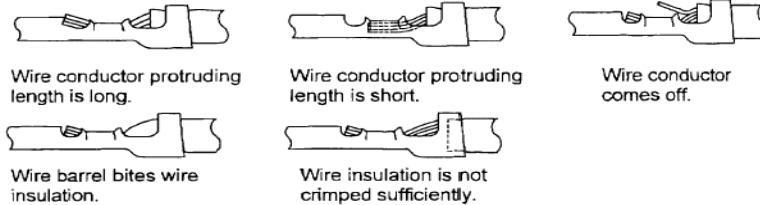

Check of crimping appearance visually for correct crimping as referring to above Fig.2  
 Check the tensile strength at crimped part when operation finishes.

Table of tensile strength at crimped part.

SPHD-001T-P0.5

Wire size	Requirement N min.	Actual value N
UL1007 AWG#26	20	39.2 ~ 45.1
UL1007 AWG#24	30	68.6 ~ 74.5
UL1007 AWG#22	40	92.1 ~ 96.0

SPHD-002T-P0.5

Wire size	Requirement N min.	Actual value N
UL1007 AWG#28	15	27.0 ~ 34.3
UL1007 AWG#26	20	44.1 ~ 48.0
UL1007 AWG#24	30	66.6 ~ 71.5

**c). Inserting contact into housing**

Inserting crimped contact into housing

- (1) Do not apply any pulling force to crimped part, and insert contact parallel to housing
- (2) Insert contact into housing without stopping to innermost
- (3) Check secure locking per each insertion by pulling wire softly in order to check that contact does not come off housing. Besides, check whether there is the backlash in the direction of insertion axis.

Defect example of slation insertion

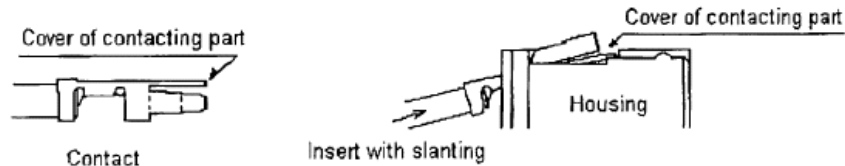

**d). Mating and Unmating Connector**

- (1) Inserting connector

Hold receptacle housing securely and insert into header straight against to header post until click sounds.

- (2) Unmating connector

Hold all wires securely and fix receptacle housing by fingers so as to pry, and then, withdraw it on the mating axis.

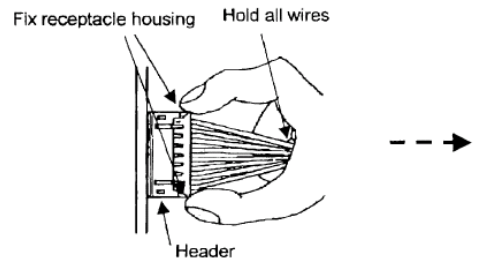

**e). Routing of Wire**

Routing wire so as not to apply external force to connector except force to such an extent that wire slightly buckles, considering an enough length to route and fixing of wire.

**7. The life expectancy**

The life of the power supply depends on the life of the built-in aluminum electrolytic capacitor being used and fan mounted products will depend on fan life. Each life is described in reliability data. The life of the aluminum electrolytic capacitor varies depending on the method of mounting the power supply, the load current, and the ambient temperature. Please refer to “Electrolytic Capacitor Lifetime”. The life of the fan depends on the fan intake or exhaust temperature. Please refer to “Fan Life Expectancy. Please do not use the product which passed over the life expectancy. There is a risk of unexpected output shutdown and specifications may not be satisfied. Please contact us for maintenance or exchange the product which passed over the life expectancy.

**8. External Fuse Rating**

Refer to the following fuse rating when selecting the external fuses that are to be used on input line. Surge current flows when line turns on. Use slow-blow or time-lag type fuse, not fast-blow fuse. Fuse rating is specified by in-rush current value at line turn-on. Do not select the fuse according to input current (RMS.) values under the actual load condition.

HWS300 : 10A  
HWS600 : 15A

## 9. Fan life expectancy

The Fan-life has limitation. Therefore, periodic maintenance by exchanging the life-expired fan is required for the power supply. The following figure shows the life of fan.

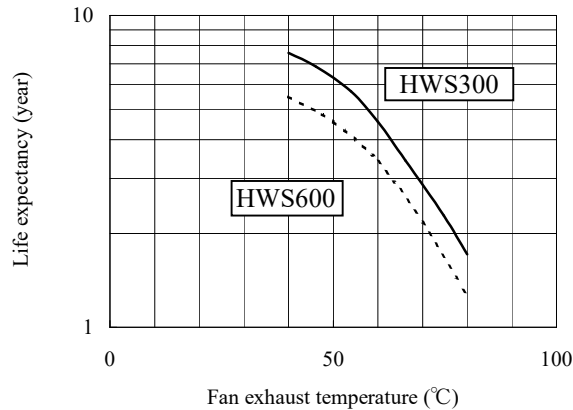

Measurement point of fan exhaust temperature

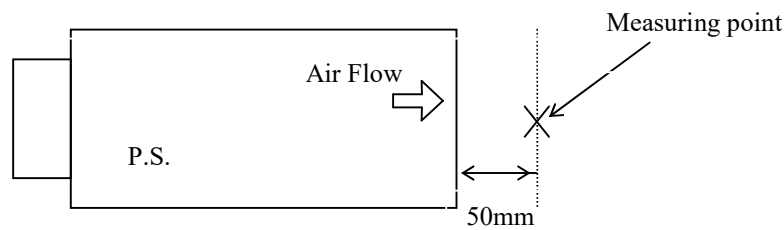

The difference between the intake temperature and the exhaust temperature of the Power supply at  $I_o=100\%$  :

HWS300 : 4°C

HWS600 : 8°C

## 10. Before concluding that the unit is at fault...

Before concluding that the unit is at fault, make the following checks.

- (1) Check if the rated input voltage is connected.
- (2) Check if the wiring of input and output is correct.
- (3) Check if the I/O terminal connection is properly tighten by regulated torque.
- (4) Check if the wire thickness is enough.
- (5) Check if the output voltage control (V.adj) is properly adjusted. OVP might be triggered and output is shut down.
- (6) If use function of the Remote ON/OFF control, check if the Remote ON/OFF control connector is not opened. If in open condition, power supply will not output.
- (7) Check if the built-in FAN is not stopped. Is FAN stopped by something irregulars or etc? If FAN stops, the PF signal turn "High" level and OTP might be activated.
- (8) Power supply has ventilating holes on the front and back panels. Check if there is any irregulars or dust, etc.
- (9) Is the chassis of power supply hot abnormally? The output is shut down by OTP operation. Please re-input after the unit to cool down sufficiently.
- (10) Check if the output current and output wattage does not over specification.
- (11) Audible noise can be heard when input voltage waveform is not sinusoidal.
- (12) Audible noise can be heard during dynamic load operation.

## 11. Warranty Period

This product is warranted for a period of 5 years from the date of shipment. For damages occurring at normal operation within this warranty period, repair is free of charge. Please read the General Safety Instruction before using the products.