

PF/PF-A Series

Application Notes

Before Using The Power Supply

Pay attention to all warnings and cautions before using the unit. Incorrect usage could lead to an electrical shock, damage to unit, or a fire hazard. Be sure read below **warning** and **caution** before using the power module.

Warning

- Do not touch heatsink and case which may be hot.
- Do not open the case and touch the internal components. They may have high temperature or high voltage which may get you in electrical shock or burned.
- When the unit is operating, keep your hands and face away from the unit. You may get injured by an accidents.

Caution

- Confirm that connections to input/output terminals and signal terminals are correct as indicated in the instruction manual.
- Attach a fast blow type external fuse to each module to ensure safety operation and to acquire each safety approval.
- This power supply is designed for professional installation within an end user equipment.
- The output of this power module is 360VDC and is considered a primary power supply. Safe design and Safety Standard requirement should be considered in application design.
- The application circuits and their parameters are for reference only. Be sure to verify effectiveness of application circuits and their parameters before finalizing circuit design.
- The information on this document is subject to change without notice. For actual design-in, please refer to the latest publications of data sheet, etc., for the most up-to-date specifications of this unit.
- No part of this document may be copied or reproduced in any form or by any means without prior written consent of TDK-Lambda.

CE MARKING :

CE Marking, when applied to a product covered by this handbook, indicates compliance with the low voltage directive.

■ Basic Connection

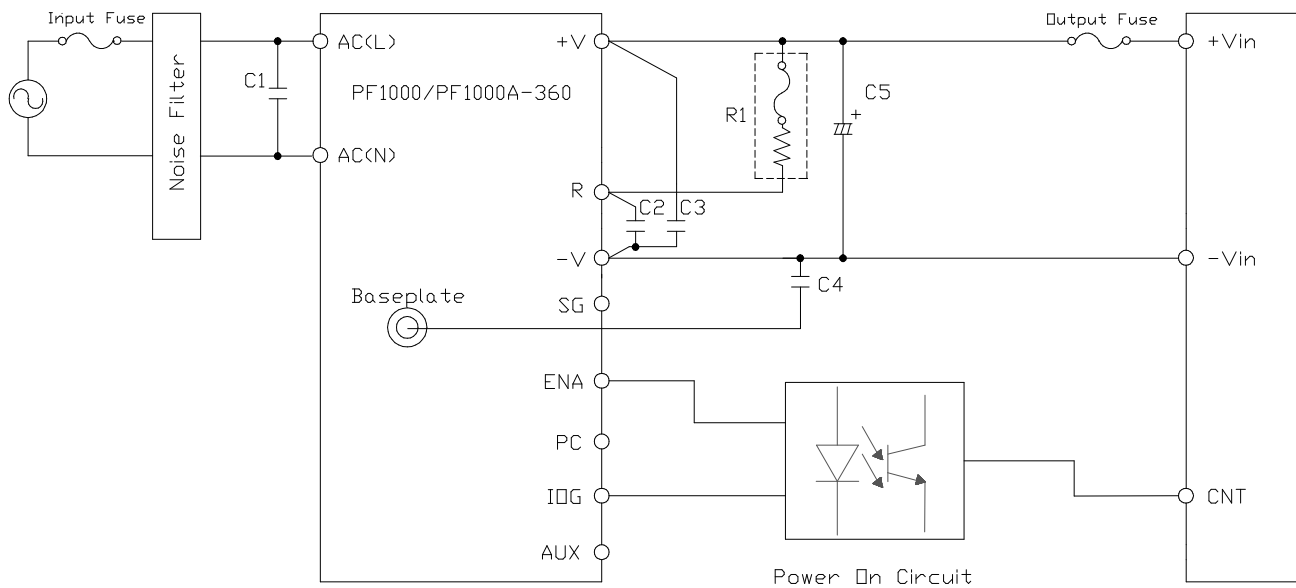

1. External Components

- a) **C1: AC250V 1 μ F**
 PF500/PF500A-360: 1pcs
 PF1000/PF1000A-360: 2pcs

Note: Input capacitor C1 should be provided to filter high frequency noise at the input of the module. AC ripple current rating must be rated for more than 3A (RMS) per capacitor. Locate C1 as closely to the terminals as possible. This will reduce unwanted oscillations formed from wiring inductance and parasitic capacitance.

- b) **C2: 630V 0.82 μ F**
 PF500/PF500A-360: 1pcs
 PF1000/PF1000A-360: 2pcs

Note: Capacitor C2 is used to snub spike noise emanating from the boost inverter particularly when the main switch turns off. AC ripple current rating must be

rated for more than 3A (RMS) per capacitor. Locate C2 as closely to the terminals as possible.

- c) **C3: 630V 0.47 μ F**
 PF500/PF500A-360: 1pcs
 PF1000/PF1000A-360: 2pcs

Note: Same as C2.

- d) **C4: AC400V 1000~4700pF**

Note: This capacitor is provided to reduce common mode circulating current. This capacitor is determined by the Overall common mode circulating current in the system and by the leakage current requirement of the system.

- e) **C5:**
 Please refer to “●Selection of External Output Capacitor” below. The possible external nominal capacitance is as follows.
 PF500/PF500A-360: 120~1200 μ F
 PF1000/PF1000A-360: 240~2000 μ F

If a value above these values is used, damage to the module could occur.

f) R1:

Please refer to “11. Input Surge Current”.

g) Power On Circuit:

Please refer to “16. Power On Signal”.

h) Input Fuse:

Please refer to “11. Input Surge Current”.

i) Output Fuse:

In order to protect the load from damage, please use an external fuse (Fast Blow Type).

Recommended Output Fuse Nominal Current.

PF500/PF500A-360: 3A

PF1000/PF1000A-360: 6A

● **Selection of External Output Capacitor**

The external output capacitor value is determined by the following factors:

- Peak to Peak Output Ripple Voltage
- Required Holdup Time
- Peak to Peak Ripple Current
- Expected Lifetime of the Capacitor

A. Peak to Peak Output Ripple Voltage

The peak to peak output ripple voltage should be minimized to less than 15Vpk-pk. This will ensure that the DC voltage bus is fairly constant for line and load changes. The following formula determines the required output capacitance needed for a peak to peak ripple voltage of less than 15Vpk-pk.

Equation 1

$$C_o \geq \frac{P_{out}}{(2\pi f \times V_{pk-pk} \times V_o \times \eta)} [F]$$

Co = Output Smoothing Capacitance

Pout = Pin of PH module

(Pin = Po(of PH module)/ η)

f = Input frequency

Vpk-pk = Output ripple voltage

(less than 15Vpk-pk)

Vo = PF/PF-A rated output voltage

(worst case = 98% of rated output voltage)

η = Efficiency of PF/PF-A module

Example

- using two PH modules (PH300F280-5 at full load current)
- Input frequency 60Hz
- Input voltage is 360VDC

Total Pout of PF/PF-A module required

$$P_o = \frac{600W}{0.83} = 723W$$

$$V_o = 0.98 \times 360 = 353V$$

The PF1000/PF1000A-360 would be required to support the total system input power of 723 Watts.

$$C_o \geq \frac{728 \times 10^{-6}}{(2\pi)(60)(15)(353)(0.94)} [F]$$

$$C_o \geq 388 \mu F$$

B. Capacitance Selection for Desired Holdup Time

The total output capacitance must also be calculated based on the required holdup time of the AC/DC power supply. The following equation relates the output capacitance to the required holdup time.

Equation 2

$$C_o \geq \frac{2 \times (P_o / \eta) \times Th}{(V_o - V_{pk-pk} / 2)^2 - (V_{min})^2} [F]$$

Co = Output Smoothing Capacitance

Po = Pin of PH module

(Pin = Po(of PH module)/ η)

η = Efficiency of PH module

Th = Required holdup time of AC/DC power supply

Vo = PF/PF-A rated output voltage
(worst case = 98% of rated output voltage)

Vpk-pk = Output ripple voltage
(less than 15Vpk-pk)

Vmin = Minimum Input Voltage of PH Module

Example

- using two PH modules (PH300F280-5) at full load current
- desired holdup: 1 line cycle at 60Hz
- η of PH module = 83%
- Vmin = 180VDC
- Vpk-pk = 15V
- Vo = 360 × 0.98 = 353VDC

$$P_o = \frac{600W}{0.83} = 723W$$

The capacitance is calculated as follows:

$$C_o \geq \frac{2 \times (723)(16.6mS) \times 10^{-6}}{\left[(353 - 15/2)^2 - (200)^2 \right]} [F]$$

$$C_o \geq 302 \mu F$$

Determine the capacitance from the results of Equations 1 and 2. The larger value should be used to obtain the desired holdup and peak to peak ripple voltage requirements.

Note: Electrolytic capacitors of low ESR type should be used.

C. Peak to Peak Capacitor Ripple Current

The peak to peak ripple current is comprised of both line frequency and switching frequency components. In a power factor corrected system, the AC peak to peak capacitor current is greatly reduced. This is due to the regulated DC bus of 360VDC that the capacitor sees even over wide input variations. This allows for a smaller capacitor that can consistently store more energy than in the conventional system at low line.

All of this results in a charging current waveform that has a peak to peak value of only twice the DC input current. That means that the RMS capacitor current is equal to $0.707 \times IDC$. This increases the reliability of the overall front end which extends itself to a better system design.

The maximum allowable ripple current of the capacitor must be greater than the actual ripple current value. The figure below shows actual ripple current versus output power. This can be used as an estimation for actual peak to peak ripple current. However, measurement of the actual current should be made to confirm system reliability.

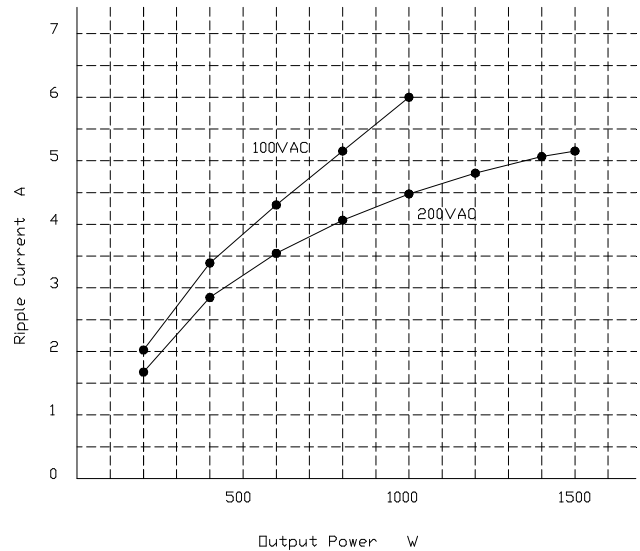

● PH Series Connection

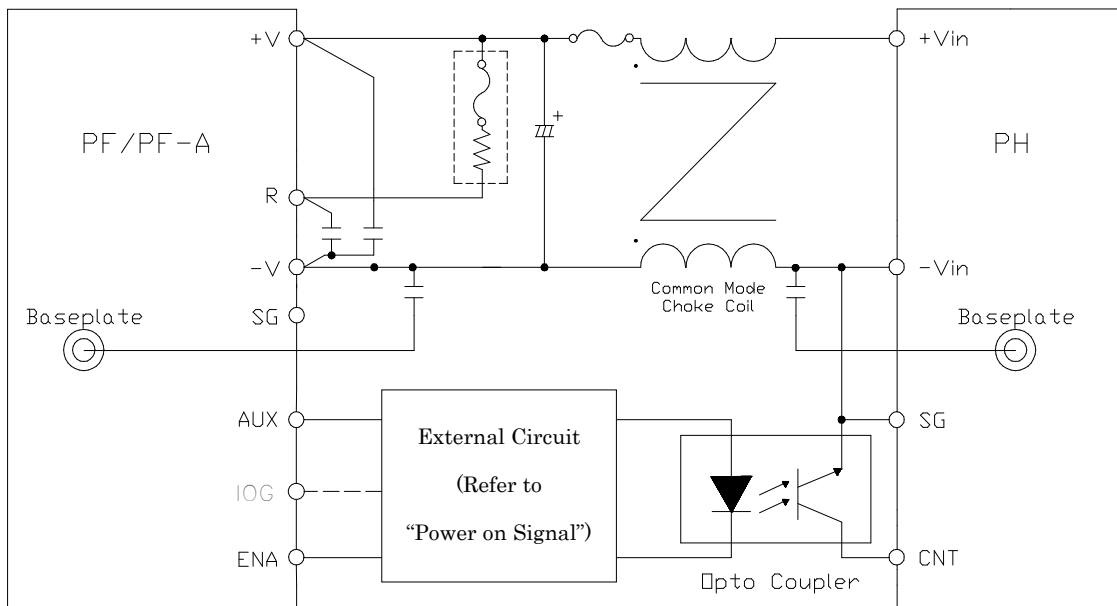

Value: 2mH

- Place a common mode choke coil across the input section of the PH series (for each module).

Common Mode Choke Coil Inductance

- Place a 4700pF capacitor on the input side of the PH series between the $-V$ terminal and baseplate (FG).

(attach to each module)

- Place a 4700pF capacitor on the output side of the PF/PF-A series between the $-V$ terminal and baseplate (FG).

(attach to each module)

- Please use (for each PH module) an opto-coupler for the ON/OFF control circuit between the PF/PF-A series and the PH series. Further, please use a opto-coupler with the transistor output having no base terminal. Also place the transistor as close to the PH series CNT and SG (or $-V$) terminals as possible.
- Short the SG terminal to the $-V_{in}$ on the PH series and to the $-V_{out}$ on the PF/PF-A series. Do not connect them directly together.
- Attach the PH series input fuse to the $+V$ side, do not place it on the $-V$ side.

2. Input Voltage Range

Input Voltage that takes into consideration each country's standard input voltage and tolerance range.

In order to meet each safety standard, the standard input voltage must be provided. The PF/PF-A modules input voltage rating is from 85~265VAC, at a frequency range of 47~63Hz. The input current is comprised of both low frequency (60Hz) and high frequency components (PF: 190kHz, PF/A: 140kHz).

3. PFHC Operation Input Voltage Range

PFHC operation will not occur with input voltage above 255VAC. The output voltage will be the full rectification of the input voltage.

4 Input Current

This is the effective value of the current supplied to the module. The value in the specifications is the value under standard input and output.

5. Nominal Output Voltage

The nominal output of the PF/PF-A360 series is 360VDC. However, this is the value when the input is under 255VAC.

6. Maximum Output Current

This is the maximum output current the module can supply to the load continuously.

7. Maximum Output Power

This is the maximum output power the module can supply to the load continuously.

The PF1000/PF1000A-360 has the capability of supplying 1000W in the 100VAC input mode and 1500W in the 200VAC input mode. The PF500/PF500A-360 can supply 500W in the 100VAC input mode and 750W in the 200VAC input mode.

The increased wattage capability at 200VAC input is primarily due to the higher efficiency (94%) achieved as compared to (90%) when operating in the 100VAC mode.

PF&PF-A Series derating must be taken as follows.

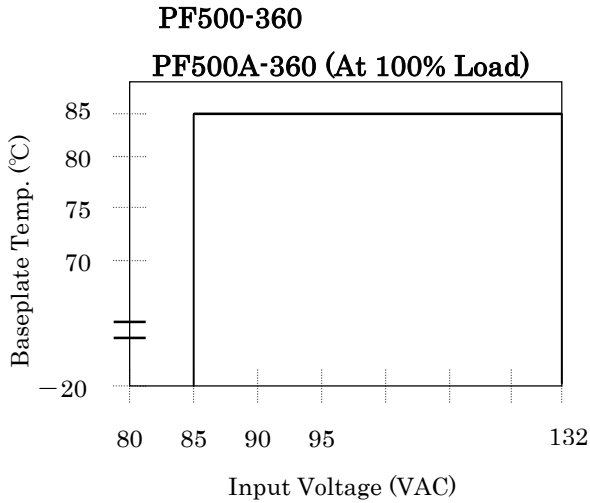

PF1000-360
PF1000A-360 (At 85°C Baseplate Temp.)

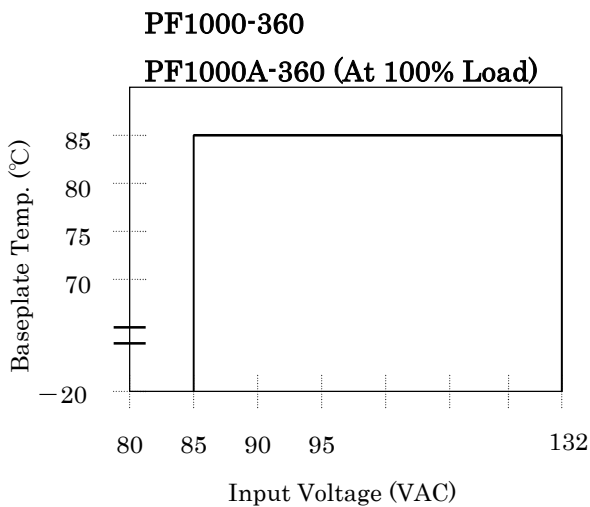
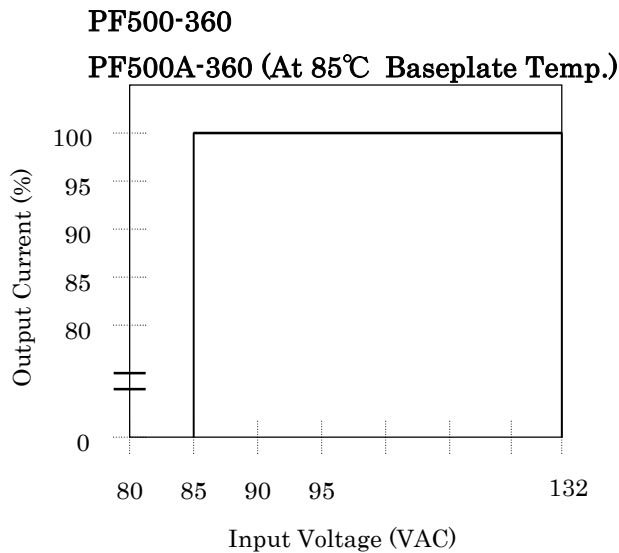
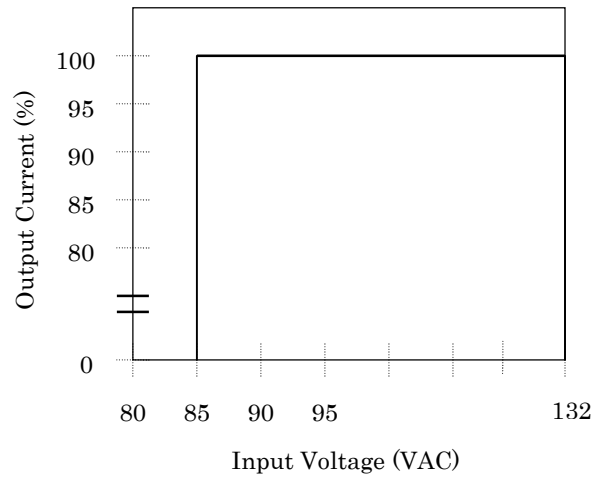

8. Efficiency

This is the ratio of the output power to the effective input power. The value in the specifications is the efficiency under standard input and output. Due to the fact that the efficiency will change with input voltage and output power, please take caution when constructing thermal design.

9. Power Factor

The percentage of effective input power vs. the apparent input power is called power factor.

10. Output Voltage Accuracy

Within the PFHC operating input voltage range, the output voltage accuracy is 360VDC ± 2%.

11. Inrush Current

Inrush current is defined as the initial peak input current drawn by the input capacitors during turn-on. This current can be very large depending on the source impedance, and can cause such problems as external fuse brown-out, melting of the contacts of a relay or tripping of a circuit breaker.

The inrush current at turn-on can be limited by connecting an external resistor between the R and +V terminals on the PF/PF-A module. This allows flexibility for the user to reduce the inrush current to meet his or her design conditions.

Note: The PF/PF-A module must be operated with an external inrush limiting resistor.

● Selection of an External Inrush Limiting Resistor

A. Determine Resistor Value

Equation 4

$$R = \frac{V_{inpk}}{I_{(inrush)}} [\Omega]$$

R = External Resistor Value (Ω)

Vin = AC RMS Input Voltage (VAC)

Vinpk = $Vin \times \sqrt{2}$

I(inrush) = Inrush Current (Apk)

B. I²t Rating of Inrush Limiting Resistor

When selecting an inrush limiting resistor

value, its I²t rating must be limited to less than the manufacturers rating. The I²t value can be computed as follows:

Equation 5

$$I^2t = \frac{C_o \times (V_{inpk})^2}{2 \times R} [A^2s]$$

I²t = Product of the current squared and time

Co = Output Smoothing Capacitance

Vinpk = $Vin \times \sqrt{2}$

R = External Inrush Limiting Resistor

It is recommended to use a thermally fused inrush limiting resistor or a resistor with a thermal fuse in series for safety protection.

● Selection of an External Input Fuse

The power module does not provide an input fuse. For safety precautions and to meet each safety approval standard, an external fuse should be connected (to each module).

A. Voltage Rating of the External Fuse

Rating	Input Voltage
125VAC	100VAC Input
250VAC	200VAC Input

B. Current Rating of the External Fuse

The standard current is determined from the maximum input current with the following formula shown below.

Equation 6

$$I_{in(max)} = \frac{P_{out}}{V_{in(min)} \times \eta \times PF} [A_{rms}]$$

$I_{in(max)}$ = Maximum Input Current

P_{out} = Maximum Output Power of PF/PF-A Module

η = Efficiency $\frac{\text{actual power}}{\text{apparent power}}$

PF = Power Factor

$V_{in(min)}$ = Minimum AC Input Voltage

External fuse input current ratings for the PF/PF-A modules are the following.

PF500/PF500A-360: 10A

PF1000/PF1000A-360: 20A

The power factor varies depending on line impedance, effective input capacitance, and output power.

C. Calculating the Required Surge Energy

The surge energy when the inrush current protection circuit does not function must be considered. If the output is above 180V when the input has been shut down, the inrush current protection circuit will not function. Please refer to Sequence Timing Chart. At this time the inrush current limiter is only the line impedance. The surge energy at this time can be calculated as follows.

Equation 7

$$I^2t = \frac{C_o \times (V_{inpk} - 180)^2}{2 \times r} [A^2s]$$

I^2t = Product of the current squared and time

C_o = Output Smoothing Capacitance

$V_{inpk} = \max V_{in} \times \sqrt{2}$

r = Input Line Impedance

Line impedance will vary depending on conditions of use. However, when using calculations, please make this value 0.5 Ω .

The I^2t value of the manufacturers rating must be greater than the calculated value from Equation 7. The fuse must also be able to support the AC RMS input current as well as the AC RMS input voltage.

12. Overvoltage Protection

The PF/PF-A series is equipped with an overvoltage protection circuit. During an overvoltage condition, the power factor correction function is disabled. The DC bus, however, is still maintained as a rectified AC input voltage. Power factor correction is restored once the AC input voltage has been manually recycled and reapplied to the PF/PF-A module. The overvoltage protection trip point is factory set and cannot be changed. When the OVP triggers, please shut down load as follows :

- a.) For PF-module : through IOG and ENA
- b.) For PF-A module : through IOG or ENA

Note: When recycling the AC input line voltage, enough time should be allowed to pass so that the DC output falls below 20VDC before the AC is reapplied.

13. Thermal Protection

The PF/PF-A modules are thermally protected in the event that their base plate temperature should rise above the trip point (85 °C ~115 °C). Once an overtemperature condition is detected, power factor correction is inhibited and only a rectified AC input voltage is provided as an output from the PF/PF-A module. Power factor correction is restored once the baseplate temperature has fallen to within operating limits and AC line voltage is reapplied. When the thermal protection triggers, please shut down the load through the IOG and ENA.

14. Parallel Operation

The PF/PF-A modules can be configured for current sharing N+1 parallel redundancy. N+1 parallel redundancy enhances system design reliability and provides the user with an option of achieving increased output power.

The PF/PF-A modules can be paralleled by connecting the “PC” pin from one module to another. This will allow equal current sharing of up to a maximum of five units in parallel (same power level). By connecting the PC terminals together, each module will sense and monitor its own output current via an analog voltage signal that is in proportion to the output current. The internal circuits of both modules

will mutually monitor and compare the voltage of one another, so that balancing is achieved for both modules.

When operating in parallel, the maximum load current drawn from each unit is up to 90% of the maximum output current that appears on the modules specification sheet.

Example

- using two PF1000/PF1000A-360 in parallel at $V_{in} = 200VAC$
- The total output current is 8.4A
- The maximum load current capability per module is given by:

$$I_{load} = 0.9 \times 8.4$$

$$I_{load} = 7.56A$$

● Application Note on Parallel Operation

Parallel operation is possible within the PFHC operation range (85~255VAC). When operating in parallel, connect the PC pins together and there will be current sharing between the models.

There are two methods of parallel operation.

- (1) Parallel Operation
- (2) N+1 parallel redundant operation.

A. Basic Connection

Parallel operation is used when there is not enough current to supply the load being used with one model, or when improving the reliability of the power supply by reducing the output power. However, if one model goes down, the output will be shut down. The basic connection is shown below.

■ Basic Parallel Operation

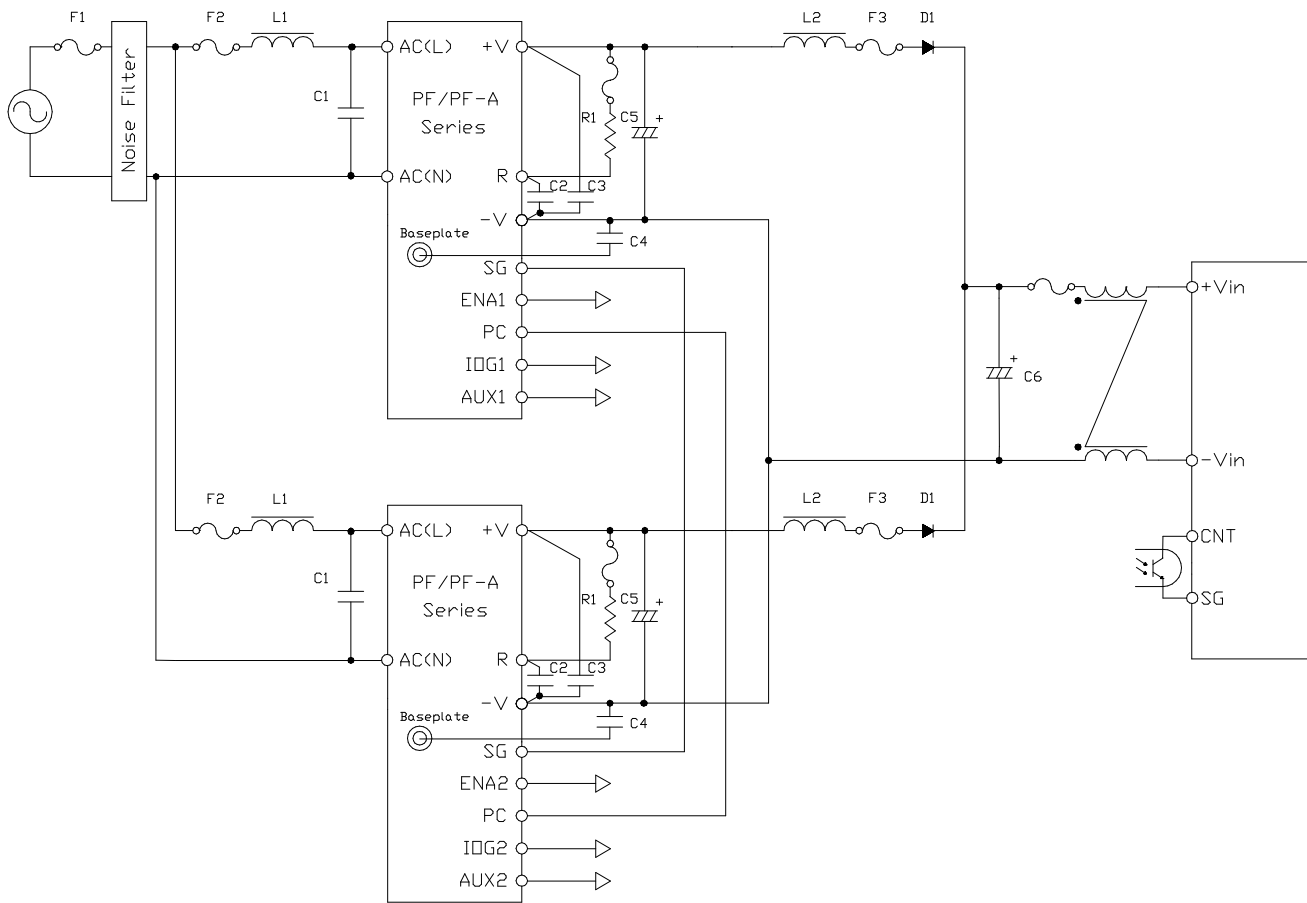

B. Parallel Redundant Operation

In power supply systems demanding high reliability, N+1 modules can be used for the N module power supply, increasing the reliability of the system. In normal operation, the output power of each module will be lower, also raising the reliability of the system.

If one module goes down within the N+1

modules, the remaining N modules can still supply the load current and protection from the system going down is accomplished. However, a bridge diode and input fuse (standard DC) is required. When selecting the bridge diode as well as input fuse, please consider not only the time in standard operation, but also the inrush withstand current. The basic connection is shown below.

■ N+1 Parallel Redundant Operation

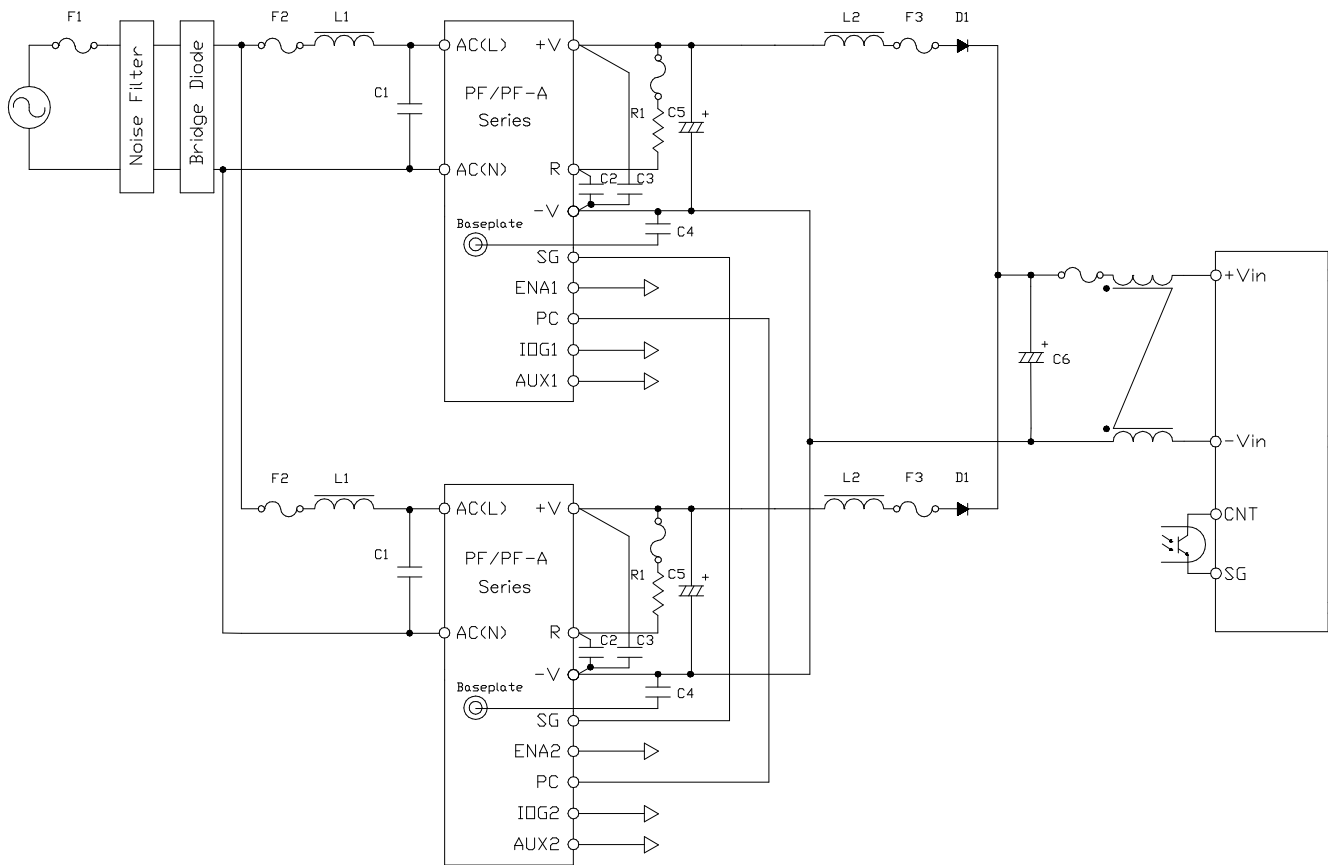

C. In Order to Operate in Parallel

In order to operate in parallel, the following basic caution points should be considered.

- Input Voltage Range: 85~255VAC

If this range is exceeded, there will be no current sharing and damage to the module could occur.

- Maximum Possible Modules in Parallel:
5 units Models must be of similar type.
PF500/PF500A and PF1000/PF1000A cannot be operated in parallel.

-Connection for Each Signal:

Make sure that the power on signal (ENA) and IOG signal (IOG) are used. Only when both of these signals are LOW, the operation is normal, and possible output is displayed. If one of the signals is abnormal (HIGH), the module is thought to be abnormal. Please make the output in "OFF" condition.

- SG Terminal Connection

The SG terminal is connected inside the module to the -V terminal. However, to make the module's operation more steady, discriminate from the output line (power line). To make the ground level even between each SG

terminal, short each $-V$ terminal to the SG terminal.

- Output Derating: Under 90%

When operating in parallel, derating is needed to achieve the current sharing accuracy. Please use at 90% or below of each module's maximum power rating. Further, take note that depending on the input voltage, the standard output will change.

- Output Smoothing Capacitor:

When operating in parallel, a situation will be produced where the output capacitance exceeds each PF/PF-A series upper limit. The inrush current due to the output capacitor can damage the module. Therefore, in order to fulfill each module's maximum external output capacitance (inrush current capacitance), be sure to attach an output diode.

- Insertion of Normal Mode Choke Coil

To avoid malfunction due to noise from the input and output lines, please insert an input and output normal mode choke coil.

- Parallel Redundant Operation

When operating in parallel redundant mode, please be sure to full wave rectify by place a bridge diode on the input. If a bridge diode is not inserted, when one module fails there is the possibility of all of the input fuses blowing and the system's output dropping out. Further, when operating in redundant mode as a power supply system, there is a redundant operation method for each

system (PH, or PT etc. used as the secondary).

- Input Fuse

For safety reasons, please place a input fuse on the input of each module.

Further, we recommend placing an apparatus input fuse on the input section.

- Wiring

The standard is to wire short and thick. Especially, wire the output $-V$ terminals short and thick.

● **Determining the Recommended External Component Values**

a) **F1: AC Input Fuse**

Please select a component that meets the following recommended conditions.

○ **Standard Voltage**

100VAC Input Series: 125VAC

200VAC Input Series: 250VAC

○ **Standard Current**

Please choose a component above N (paralleled units) \times the calculated input current of each PF/PF-A module.

Further, for the standard current, please select the components so that $F1 > F2$.

○ **Withstand Surge Current**

Please calculate the withstand surge current with the following formula.

Equation 8

$$I^2t = N^2 \times A \left[A^2s \right]$$

I²t: Withstand Surge Current needed for F1

N: Parallel Operation Units

A: Withstand Surge Current needed for F2 (refer to Equation 9)

Further, when calculating with the above conditions, the value will be on the large side compared to the actual measured value. Therefore, base your selection on the measured value for the withstand surge current.

b) F2: PF/PF-A Input Fuse

When the line from the PF/PF-A series output to the PH/PT series is long, an input electrolytic capacitor is needed to stabilize the PH/PT series input voltage. Therefore, when inserting an input electrolytic capacitor, a surge current will be added to F2. Please consider the sum of the PF/PF-A series output smoothing capacitors C5 and C6 with the following equation.

Further, C6 must be considered with all PF/PF-A series modules in parallel operation.

Equation 9

$$A = \frac{(C5 + C6) \times V_a^2}{2 \times r} \left[A^2s \right]$$

A: Withstand Surge Current needed for F2

C5: Output Smoothing Capacitor

C6: Secondary Input Electrolytic Capacitor (consider the tolerance)

V_a: Input 200V Series V_{in} – 180

Input 100V Series V_{in}

However, V_{in} is the maximum input voltage DC conversion value.

r: Input Line Impedance

c) R1: Input Surge Current Protective Resistor

For the input surge current protective resistor, the output smoothing capacitance must be considered in the same way as for the PF/PF-A input fuse.

d) L1: Normal Mode Choke Coil

Please select an input interference protective normal mode choke coil that meets the following conditions.

○ Recommended Inductance Value

10μH: 5~30 μH

Please select a similar component for the output interference protective normal mode choke coil L2.

e) D1: Output Diode

Please select an output diode that meets the following conditions.

○ Reverse Withstand Voltage

600V or above.

○ Standard Current

Allow a good margin vs. the output current of the PF/PF-A that is being used and select the appropriate standard current output diode.

○ **Withstand Inrush Surge Current**

The C6 charging current will flow to the output diode. On this occasion the withstand current will be as shown in the following equation.

Equation 10

$$I^2 t = \frac{C6^2 \times Va^2}{2 \times r(C5 + C6)} [A^2 s]$$

I²t: Withstand Surge Current needed for D1

C5: Output Smoothing Capacitor

C6: Secondary Input Electrolytic Capacitor
 (please consider the tolerance)

Va: Input 200V Series Vin – 180

Input 100V Series Vin

However, Vin is the maximum input voltage DC conversion value.

r: Input Line Impedance

f) F3: Output Fuse

F3 is the abbreviation in the case that an input fuse is connected to all the DC-DC converters.

g) C6: PH/PT Input Electrolytic Capacitor

When the wiring from the PF/PF-A series to the PH/PT series is long and there is a large voltage drop and regulation, please place this capacitor to the input section of the PH/PT series.

Please select the capacitor so that the sum of C5 and C6 does not exceed the PF/PF-A series maximum external output capacitance.

Further, ripple current will flow through this capacitor. Please check and select a component that satisfies the ripple current.

○ **Standard Voltage**

400WV or above

h) Bridge Diode

Please select a bridge diode that satisfies the conditions below.

○ **Withstand Voltage**

100VAC Input Series: 400VAC

200VAC Input Series: 600VAC

○ **Standard Current**

Please choose a component above N (paralleled units) × the calculated input current of each PF/PF-A module.

○ **Withstand Inrush Surge Current**

Select a value similar to the F1 withstand inrush surge current.

Further, when attaching a bridge diode to each module unlike in the redundant operation basic connection, please select a standard current and withstand inrush surge current similar to F2.

Also, please take note of the heat generated by the bridge diode.

● **Signal Connection for Parallel Operation.**

The parallel and redundant operation signal connection for the PF/PF-A series to the secondary PH/PT series is recommended as follows.

Parallel Operation Signal Connection.

(PF Connection)

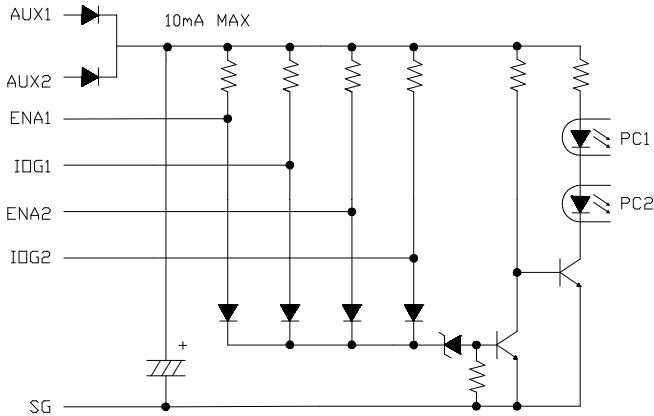

(PF-A Connection)

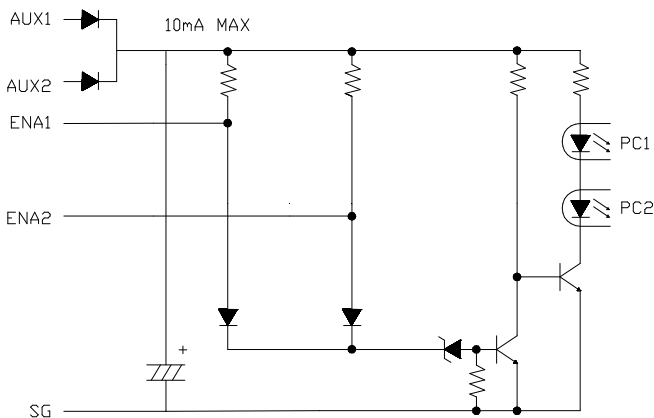

N+1 Parallel Redundant Operation Signal Connection

(PF Connection)

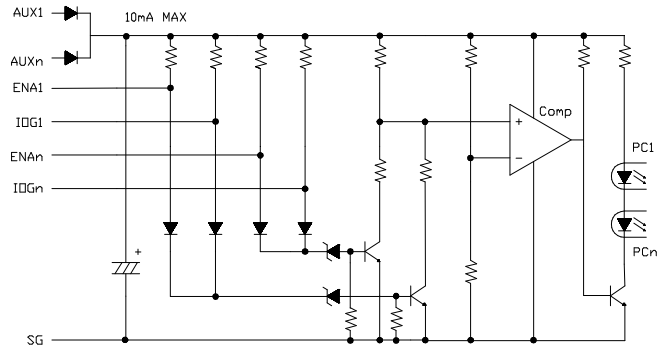

(PF-A Connection)

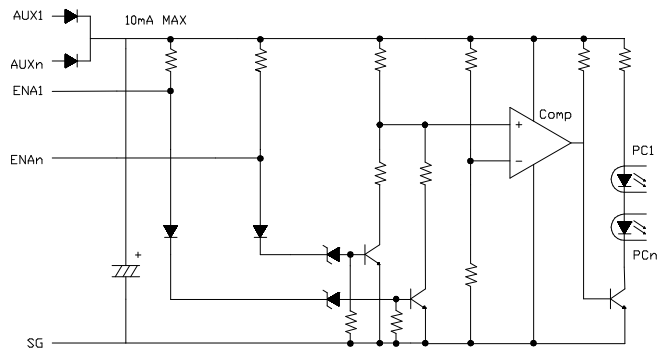

Please select a electrolytic capacitor or 100 μ F or below for the capacitor connected to the AUX terminal.

Further, 0.1 μ F capacitors have a good effect in removing noise between the ENA, IOG terminals and SG terminal.

Upon module power supply development, depending on the PCB to be loaded on and the construction, applications not mentioned above may be needed. Please confirm with the actual equipment being used.

15. Inverter Output Good Signal (IOG Terminal)

In a system that is using N+1 redundancy, hot plugability must be an option to the user. By allowing a module to be replaced (such as a defective or damaged module), without shutting down the AC input power, system reliability can be increased and “down time” minimized. The PF/PF-A module has an IOG pin that allows the user access to monitor each module’s operation status. The IOG pin monitors the module’s inverter operation by providing an open collector output signal.

Normal operation is indicated as a low (maximum sink current: 5mA, maximum applied voltage: 35V). When monitoring the IOG terminal, the return should be connected to the SG terminal as in the following diagram (SG is connected internally to the -V terminal).

Please take note that the time from when the PFHC goes off until the time the IOG goes high is 500~700mS.

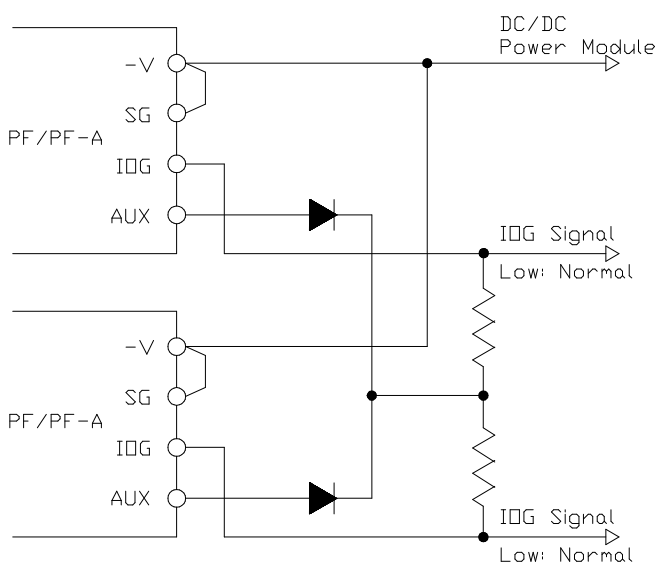

16. Power ON Signal (ENA Terminal)

The PF/PF-A series is furnished with a power ON monitoring signal (ENA terminal) that is supplied as an open collector type. This signal monitors the output voltage of the PF/PF-A module and indicates when it is at a high enough voltage to support proper operation. When the output voltage is at its proper level (greater than 350VDC), the power ON signal is in its low state (maximum sink current : 5mA, maximum applied voltage: 35V). Please refer to the Timing Sequence Chart.

The power ON signal functions to ensure that the load of the PF/PF-A module (ie: PH module) remains in the off state until the module reaches its appropriate output voltage. At initial turn on of a power supply, there exists a high peak inrush current that charges up the input capacitors. If a load is drawn from the bulk storage capacitors before the PF/PF-A module reaches its normal operating voltage, the DC bus voltage can drop, causing a possible undervoltage lockout condition. This can prohibit the PF/PF-A module from operating properly. To prevent this from happening, the following circuitry should be added when combining PF/PF-A and PH modules.

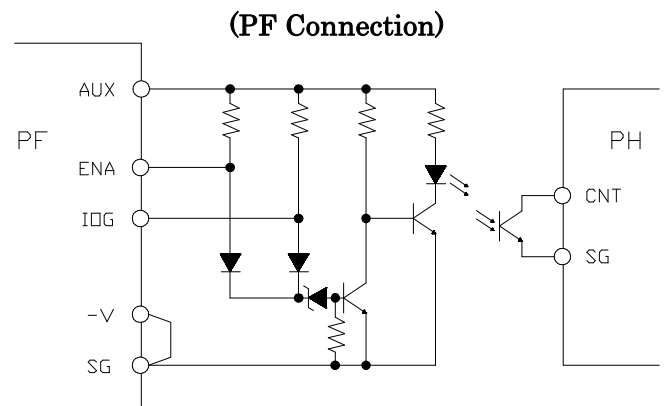

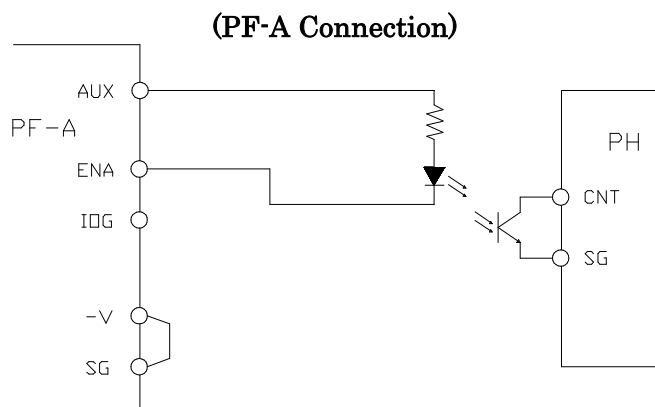

The optically isolated circuit shown above uses the auxiliary bias supply of the PF/PF-A module to “hold off” the PF/PF-A module until sufficient voltage at the output of the PF/PF-A module is reached.

Note : This circuit can also be controlled via an external 0~5VTTL signal in place of the auxiliary supply. The return of the ENA pin is the SG terminal.

17. Auxiliary Power Supply for External Signal (AUX Terminal)

PF/PF-A modules are equipped with an auxiliary power supply (AUX terminal) to provide power for external system or “housekeeping” circuitry. The output voltage range is from 12~20VDC at an maximum output current of 10mA. When using parallel operation, the AUX terminals should be diode isolated as shown in the diagram for the IOG signal. In this case as well, the maximum output current is 10mA. The return for the AUX signal is the signal ground terminal (SG).

18. Operating Temperature

The baseplate temperature must be limited to less than 85°C. For details on the thermal design, please refer to the Application Note “Thermal Design”.

19. Operating Humidity

Avoid the buildup of condensation on or in the power module.

20. Storage Temperature

Sudden temperature changes can cause condensation buildup and possible power module failure.

21. Storage Humidity

High temperature and humidity can cause the terminals on the module to oxidize.

22. Cooling Method

The operating temperature is specified by the baseplate temperature (limited to 85 °C). Various heatsink designs are possible. for detailed heatsink design, refer to the Application Note “Thermal Design”.

23. Withstand Voltage

The power module is designed to withstand 3kVAC between the input and baseplate, and

between the input and output for 1 minute. In the case that the withstand voltage is tested in the incoming goods test, etc., please set the limit of the withstand voltage test equipment to 20mA. The applied voltage must be increased gradually from zero to the testing value, and then decreased gradually at shut down. Especially stay away from use of a timer, where a pulse of several times the applied voltage can be generated. This could cause damage to the module. Be sure to short the output side as shown below.

Further, the Withstand Voltage Test is basically a breakdown test. Please limit the number of tests to as few as possible.

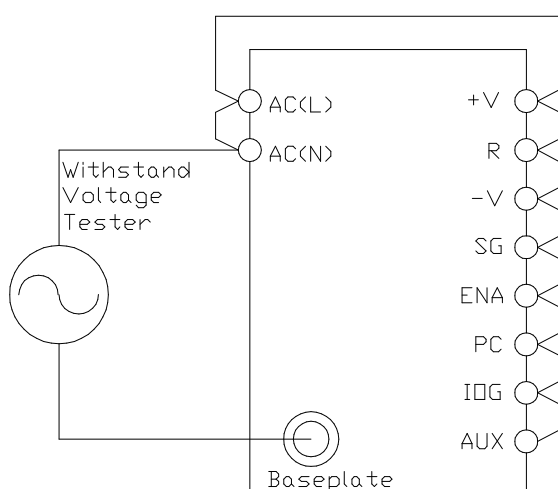

24. Isolation Resistance

The isolation resistance is more than 100M Ω at 500VDC when tested with a DC isolation tester between output and baseplate and input and baseplate. Note when testing, some isolation testers can produce a high pulse when

the applied voltage is changed over. Ensure to discharge the module with a resistor after the test.

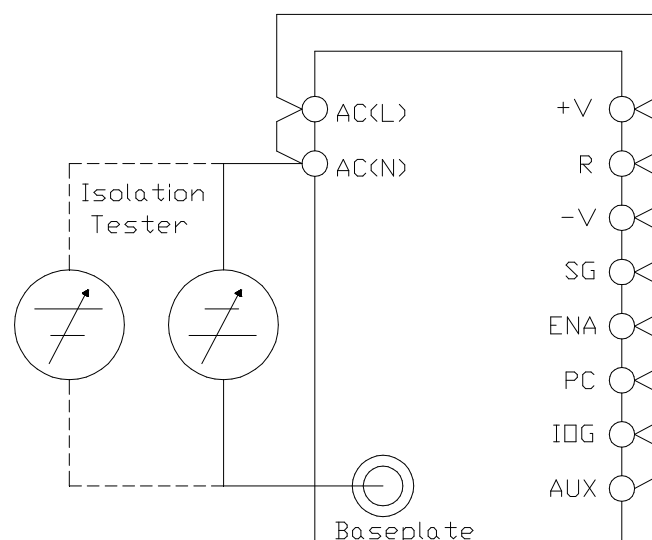

25. Vibration

Please refer to the “Installation” application note.

26. Shock

Value for the conditions of our shipping and packaging.

27. Block Diagram • Sequence Chart

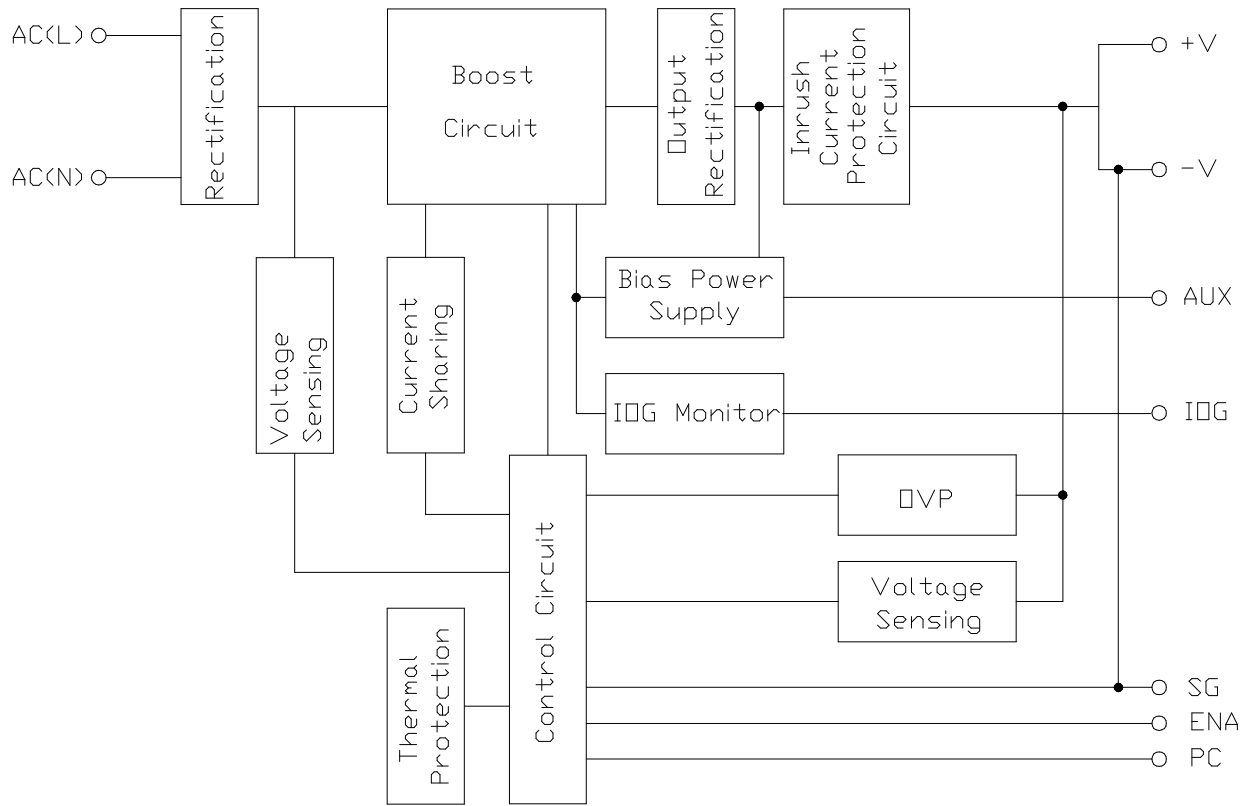

PF Sequence Chart

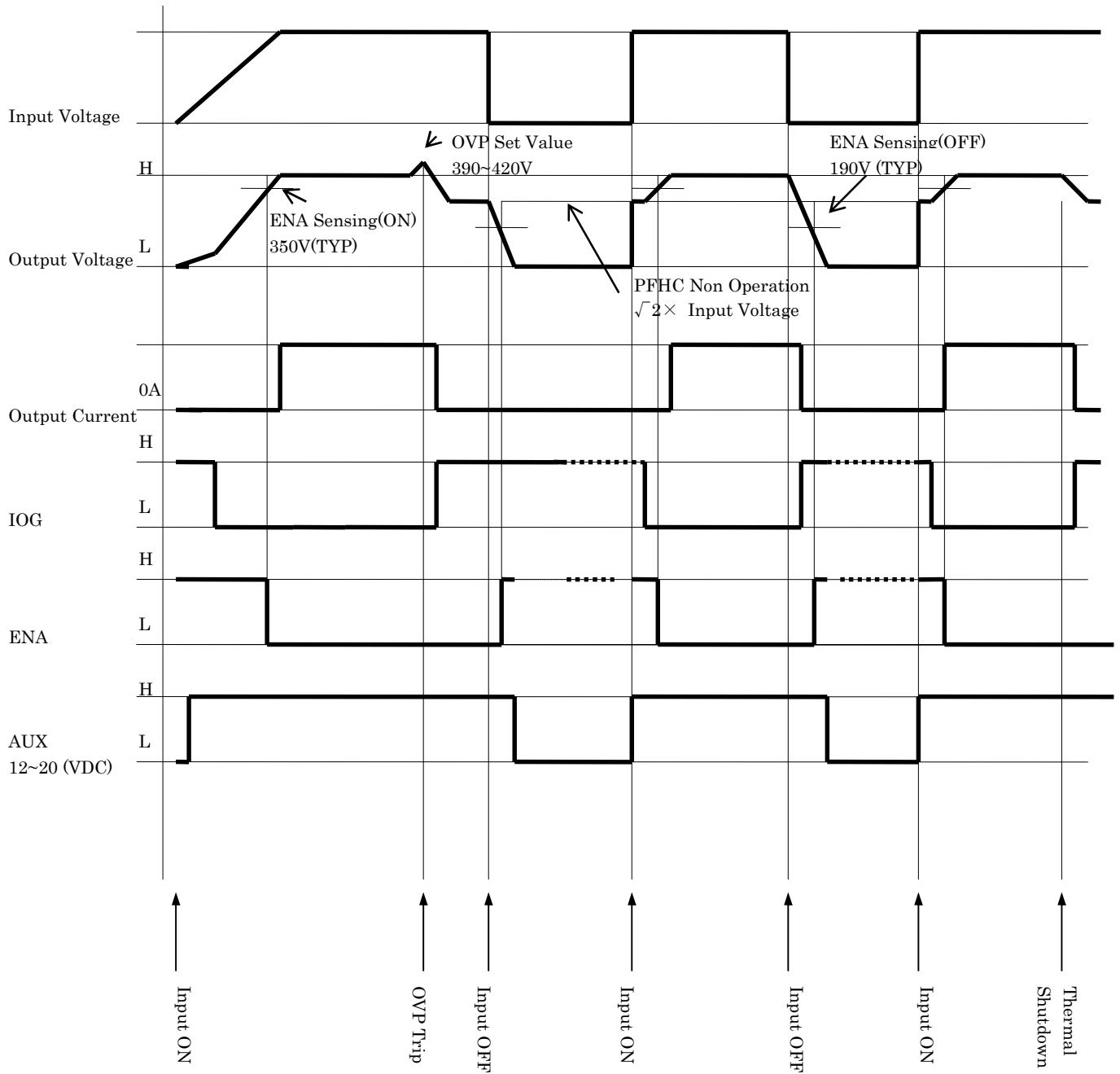

PF-A Sequence Chart

