

RP-60-20

Instruction Manual

BEFORE USING THE PRODUCT

Be sure to read this instruction manual thoroughly before using this product. Pay attention to all cautions and warnings before using this product. Incorrect usage could lead to an electrical shock, damage to the unit or a fire hazard.

DANGER

- Never use this product in locations where flammable gas or ignitable substances are present.

INSTALLATION WARNING

- When installing, ensure that work is done in accordance with the instruction manual. When installation is improper, there is risk of electric shock and fire.
- Installation shall be done by Service personnel with necessary and appropriate technical training and experience. There is a risk of electric shock and fire.
- Do not cover the product with cloth or paper etc. Do not place anything flammable around. This might cause damage, electric shock or fire.

WARNING on USE

- Do not touch this product or its internal components while circuit in operation, or shortly after shutdown. You may receive a burn.
- While this product is operating, keep your hands and face away from it as you may be injured by an unexpected situation.
- There are cases where high voltage charge remains inside the product. Therefore, do not touch even if they are not in operation as you might get injured due to high voltage and high temperature. You might also get electric shock or burn.
- Do not make unauthorized changes to this product nor remove the cover as you might get an electric shock or might damage the product. We will not be held responsible after the product has been modified, changed or dis-assembled.
- Do not use this product under unusual condition such as emission of smoke or abnormal smell and sound etc. Please stop using it immediately and shut off the product. It might lead to fire and electric shock. In such cases, please contact us. Do not attempt repair by yourself, as it is dangerous for the user.
- Do not operate and store these products in environments where condensation occurs due to moisture and humidity. It might lead fire and electric shock.
- Do not drop or apply shock to this product. It might cause failure. Do not operate these products mechanical stress is applied.

CAUTION on MOUNTING

- Confirm connections to input/output terminals are correct as indicated in the instruction manual before switching on.
- Input voltage, input current, ambient temperature and ambient humidity should be kept within specifications, otherwise the product will be damaged.
- Input/output line, please use the wires as short and thick as possible.
- Do not use this product in special environment with strong electromagnetic field, corrosive gas or conductive substances and direct sunlight, or places where product is exposed to water or rain.
- Mount this product properly in accordance with the instruction manual, mounting direction and shall be properly be ventilated.
- Please shut down the input when connecting input and output of the product.
- When mounted in environments where there is conductive foreign matter, dust or liquid, there is possibility of product failure or malfunction. Such as install filter, please consider that a conductive foreign matter, dust and liquid do not invade inside the product.

CAUTION on USE

- Before using this product, be sure to read the catalog and instruction manual. There is risk of electric shock or damage to the product or fire due to improper use.
- Input voltage, Input current, ambient temperature and ambient humidity should be kept within specifications, otherwise the product will be damaged, or cause electric shock or fire.
- Apply over current protection device such as external fuse, breaker, etc., because this product dose not have built-in protection circuit.
- For externally mounted fuse do not use other fuses aside from our specified and recommended fuse.

- As our product is standard industrial use product that was manufactured by purpose that is used to an general electronics equipment etc., it is not products that to designed for High Safety uses (Uses extremely high reliability and safety are required, if reliability and safety has not been secured, with significant dangerousness for directly life or body) is expected. Please consider a fail safe (Systems that were provided with protection circuit protective devices or systems that redundant circuit were mounted so that was not unstable in single failure) design enough.
- When used in environments with strong electromagnetic field, there is possibility of product damage due to malfunction.
- When used in environment with corrosive gas (hydrogen sulfide, sulfur dioxide, etc.) , there is possibility that they might penetrate the product and lead to failure.
- When used in environments where there is conductive foreign matter or dust, there is possibility of product failure or malfunction.
- Connect together the earth mounting hole of the product and the ground terminal of the equipment for safety and noise reduction. If these ground is not connected together, there is risk of electric shock.
- Take care not to apply external abnormal voltage to the output. Especially, applying reverse voltage or overvoltage more than the rated voltage to the output might cause failure, electric shock or fire.
- Do not use this product in special environment with strong electromagnetic field, corrosive gas or conductive substances and direct sunlight, or places where product is exposed to water or rain.
- PCB stress such as bending, twisting etc. could cause damage. Therefore, please handle with care.
- When handling this product, hold the board edge and take care not to touch the component side. When installing this product in apparatus or equipment, mount it on spacers.
- The output power is considered to be a hazardous energy level (The voltage is 2V or more and the power is 240VA or more). It must not be made accessible to users. Protection must be provided for Service Engineers against indirect contact with the output terminals and/or to prevent tools being dropped across them. While working on this product, the input power must be switched off and the input and output voltage should be zero.

 **Note**

- Consider storage of the product at normal temperature and humidity avoiding direct exposure to sunlight at environment with minimal temperature and humidity changes. Storage of product at high temperature, high humidity and environments with severe changes in temperature and humidity might cause deterioration, and occurrence of condensation in the product.
- When disposing product, follow disposal laws of each municipality.
- If products are exported, please register the export license application etc. By the Government of Japan according to Foreign Exchange and Foreign Trade Control Law.
- The Information in the catalog or the instruction manual is subject to change without prior notice. Please refer to the latest version of the catalog or the instruction manual.
- No part of this document may be copied or reproduced in any form without prior written consent of TDK-Lambda.

Note : CE MARKING

CE Marking, when applied to a product covered by this handbook, indicates compliance with the low voltage directive.

1. Product Explanation

1-1. Outline

This product is an ideal diode module using the N channel MOS-FET with low on-resistance.

This product can be used as a substitute module of the diode module for ORing of redundant operation or high current diode application.

This product monitors the input voltage and the output voltage in the inside of product. The internal MOS-FET is controlled so that the MOS-FET is on when the input voltage is higher than the output voltage and the MOS-FET is off when the input voltage is lower than the output voltage.

1-2. Features

- Ideal Diode Module as replacement of Diode Module
- Lower loss than the Diode Module
- Terminal Block design
- Safety standard certification (UL60950-1, CSA60950-1, EN60950-1)

1-3. Applications

Applications

- Computer System, Server
- Solar Power Generation System
- Telecommunication, Infrastructure

Usage

- Battery Charger
- Redundant Operation of Power Supply

1-4. System Configuration Example

Show below an example of the application using this product.

• Battery Charger

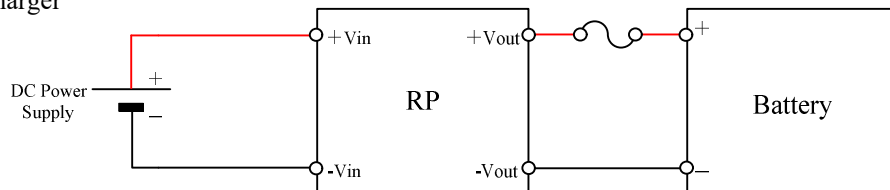

• Redundant Operation of Power Supply

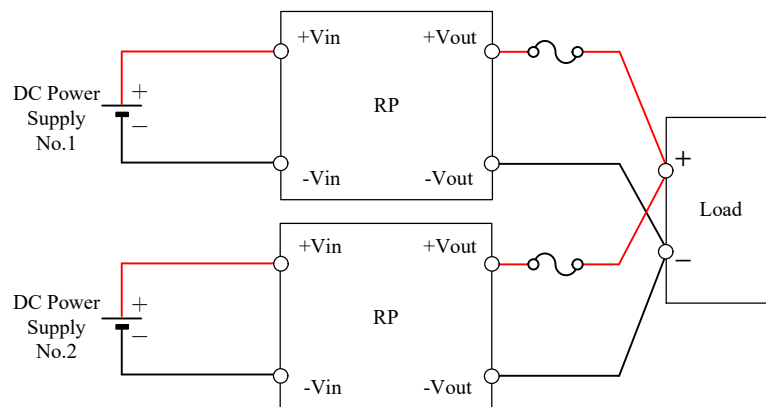

1-5. Block Diagram

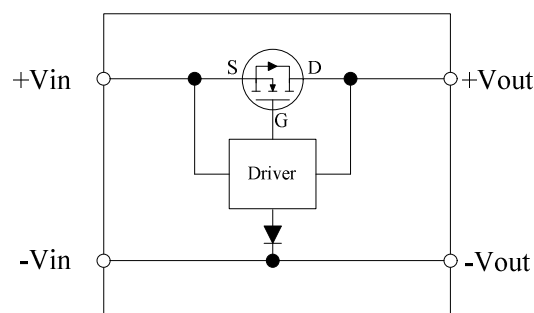

1-6. Operation for load

When current flows from power supply to the load, MOS-FET will be ON. The loss and voltage drop is lower compares to general purpose diode.

If the input terminal voltage is less that the output terminal voltage, MOS-FET will be OFF and will prevent the current from flowing from the load to power supply.

The reverse current is less than 50uA.

※CAUTION:

Please be careful about wiring to the battery load. The short current from battery might be caused in case of mistaking the wiring method with this product and battery or in case of short circuit failure of this product.

Please apply over current protection device such as fuse or breaker etc. to every product between this product and battery.

2. Model Name Identification Method

RP - 60 - 20 / □

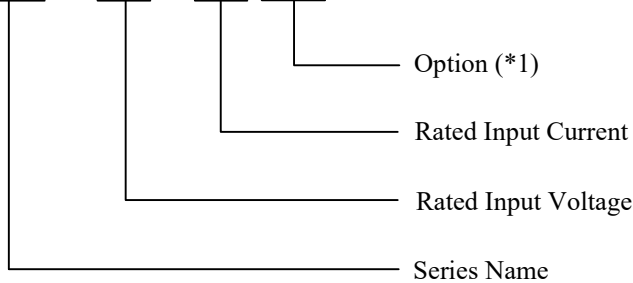

(*1) Blank : Standard
/L : With chassis model.

3. Terminal Explanation

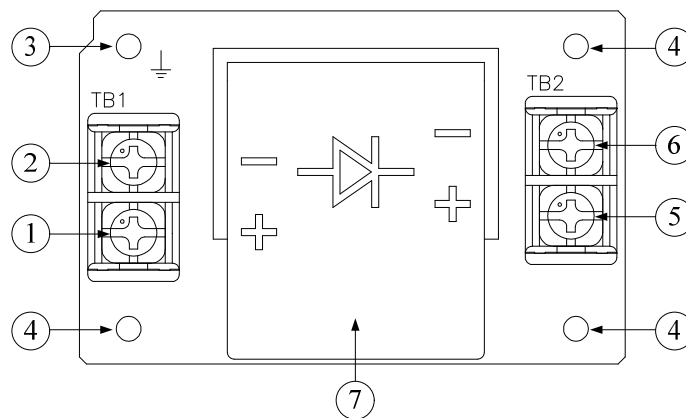

- ① +Vin : +Input terminal(M4 screw)
- ② -Vin : -Input terminal(M4 screw)
- ③ Earth mounting hole \perp (hole diameter : ϕ 3.5mm)
Must be connected to Chassis(Conductor) of the equipment by metal spacer.
The mounting surface of the spacer should be within ϕ 8mm.
- ④ Mounting hole (hole diameter : ϕ 3.5mm)
- ⑤ +Vout : +Output terminal(M4 screw)
- ⑥ -Vout : -Output terminal(M4 screw)
- ⑦ Heat Sink
Conducted to Earth mounting hole.
The mechanical stress to the Heat Sink could cause damage. Therefore, please handle with care.

Recommended torque : M4 screw 1.2N·m (12.3kgf·cm) ~ 1.6N·m(16.3kgf·cm)

4. Terminal Connecting Method

4-1. Connecting Method

Pay attention to the output wiring. If it is connected to wrong terminal, the product will be damaged.

- (1) Input must be off when making connections.
- (2) Earth mounting hole should be connected to the protective earth terminal of the equipment.
- (3) Do not apply stress to PCB and Heat Sink, when making connections.

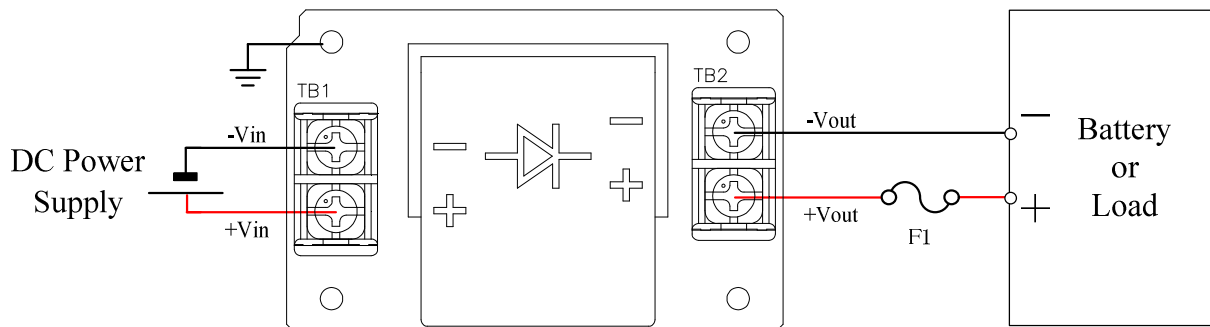

4-2. External Fuse Rating & Caution when Connecting with Battery

The product has no built-in fuse. If it is necessary, please add fuse or breaker.

When the product is connected to a battery with wrong terminal, there is risk to flow the short circuit current from the battery to the product. Please put the fuse or breaker between the battery and the product. Please take care not to exceed rated current for other application than the battery. If there is any risk to exceed rated current, please put fuse etc.. Please put medium time-lag fuse to each product. The fuse should be attached to +V line when -V is grounded or vice versa.

Recommended fuse rating is 30A or less.

4-3. Caution on Short of Output Terminal

When the output of the product has been short-circuited, there is a possibility that the power supply voltage on input side drops and the current increasing.

In this case, the MOS-FET of product will be OFF and the current flows through the body-diode of the MOS-FET. If such a status continues, the product might be damaged by the heat generation of the body-diode in the MOS-FET.

You must stop to use the product immediately when you find this situation.

4-4. Caution when using switch and breaker

In the case of voltage drops by more than 200mV, MOS-FET will be OFF and it might be a risk that the current flows through the body-diode of the MOS-FET.

Therefore, please stop immediately as the product may be damaged or may not be function in the correct usage condition.

5. Explanation of Functions and Precautions

5-1. Input Voltage

Input voltage range is 7-60VDC.

Input voltage, which is out of specified range, and reverse voltage might lead this product damage.

※Notes for low input voltage applied :

If the input voltage is lower than the 7V continuously by current limit of input power supply, the MOS-FET of the product will be OFF. In this case, the current flows through the body-diode of the product and the product might be damaged by the heat generation of the body-diode in the MOS-FET. You must use with input voltage range of 7-60VDC.

5-2. Output Voltage

The output voltage will be up to 200mV (at 20A) lower than the input voltage.

In the case of voltage drops by more than 200mV, the MOS-FET of product will be OFF and may be at risk the current flows through the body-diode of the MOS-FET.

The product may be damaged or may not be the correct use condition, please stop using it immediately.

Do not apply the voltage over 60V and reverse voltage on the output terminal, because the voltage will damage the product.

5-3. Input Current

Maximum input current is 20A.

Input current and output current shall be the same value.

5-4. Reverse Current

Maximum reverse current is 50uA. Reverse current is the constantly flowing current to the product from the battery side, when MOS-FET in the product is in the OFF state.

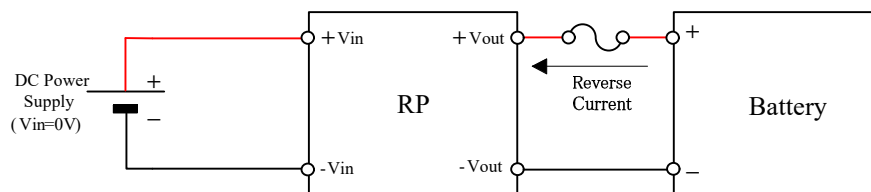

5-5. Redundant Operation

The product can be used for redundant operation as an alternative to the diode. In redundant operation, it is possible to continue supplying the power by another power supply when one power supply fails.

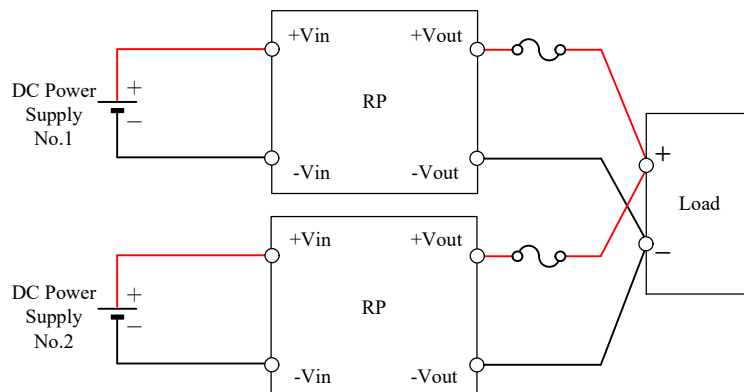

5-6. Parallel Operation

The example of the parallel operation is shown below.

Connection “ (a) ” is recommended for parallel operation.

- (a) Parallel connection to obtain the total output current more than 40A when the number of Input Source (DC Power Supply) is 2pieces or more
- (b) Parallel connection to obtain the total output current from 0A to 40A when the Input Source (DC Power Supply) is the just 1piece

- (a) Parallel connection to obtain the total output current more than 40A when the number of Input Source (DC Power Supply) is 2pieces or more
 - (1) Use the products of up to 2 units for each power supply one unit.
 - (2) When one of power supply fails, the output current of other power supplies are increased. If there are not enough margin of output current of the power supplies, shut down the power supplies as soon as possible. Or, Please put the fuse between the product and the load. In case of continuing to use the power supplies damaged, the product might be damaged.
 - (3) Please put the fuse between the product and the battery for the safety, when the product is used for the battery charging.

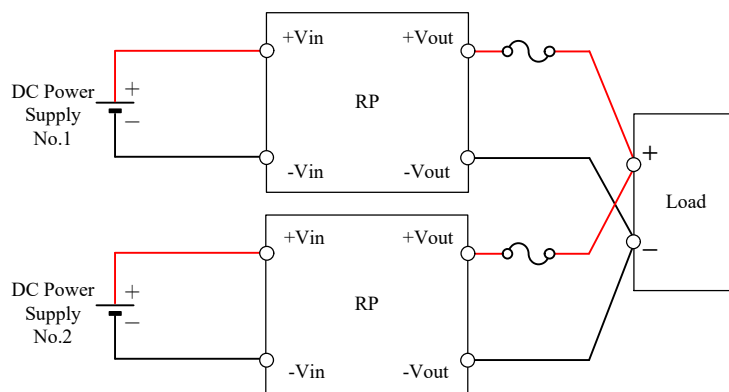

- (b) Parallel connection to obtain the total output current from 0A to 40A when the Input Source (DC Power Supply) is the just 1piece

Be careful of the following, because this product has not the balancing function of output current.

- (1) Parallel connection of the product is acceptable up to 2 units maximum.
- (2) Confirm that the output current of the product is less than 20A in each product.
- (3) Connection wires between the product and load should be same type and same length in order to achieving same wiring impedance. And the ambient temperature in each product should be kept same temperature.

In the following cases, please use the external fuse for the safety.

- (1) Connect the product to capacitive load such as battery, etc.
- (2) When there is the possibility of the output current over 20A.

Please contact our support or sales office with detail conditions, if you have any questions for parallel operation.

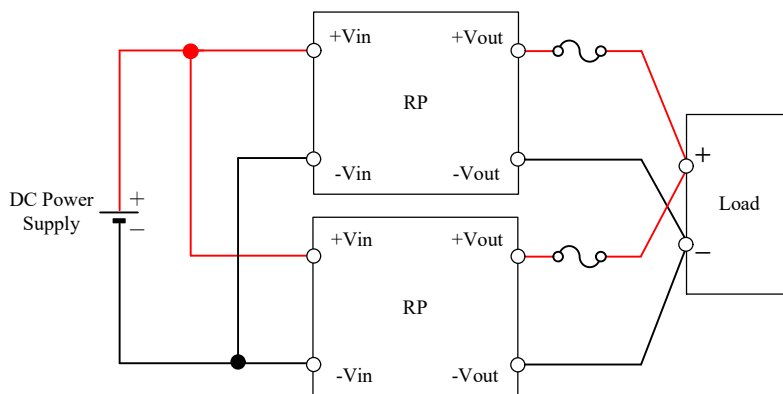

5-7 Isolation Test

Isolation resistance between Input/Output terminal - \perp mounting hole is more than 100M Ω at 500VDC.

For safety operation, voltage setting of DC isolation tester must be done before the test. Ensure that the unit is fully discharged after the test.

- Input/Output terminal - \perp mounting hole : 500VDC more than 100M Ω

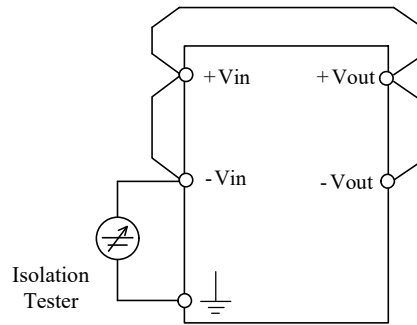

5-8. Withstand Voltage

This product is designed to withstand 500VAC between Input/Output terminal - \perp mounting hole for 1minute.

When testing withstand voltage, set current limit of withstand voltage test equipment at 20mA.

The applied voltage must be gradually increased from zero to testing value and then gradually decreased for shut down. When timer is used, the product may be damaged by high impulse voltage at switch on and off timing.

Connect input and output as follows.

- Input/Output terminal - \perp mounting hole : 500VAC, 1 min (20mA).

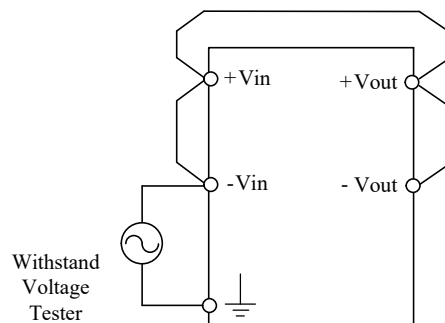

5-9. Caution on motor application use

When the back electromotive force by motors occurs, there is the risk that to output terminal apply more than 60V, the product will be damaged.

6. Mounting Method

6-1. Mounting Method

The standard mounting is direction (A). Direction (B), (C), (D) and (E) are also possible.

Do not mount the product in any other directions.

Please use output (Input and Output Current) derating within the range specified.

Refer to "6-2. Output Derating" for more information.

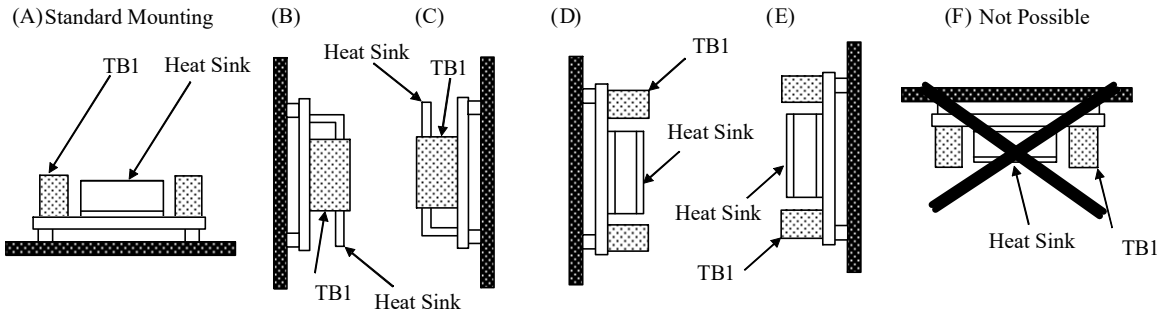

6-2. Output (Input and Output Current) Derating (Option "/L" included)

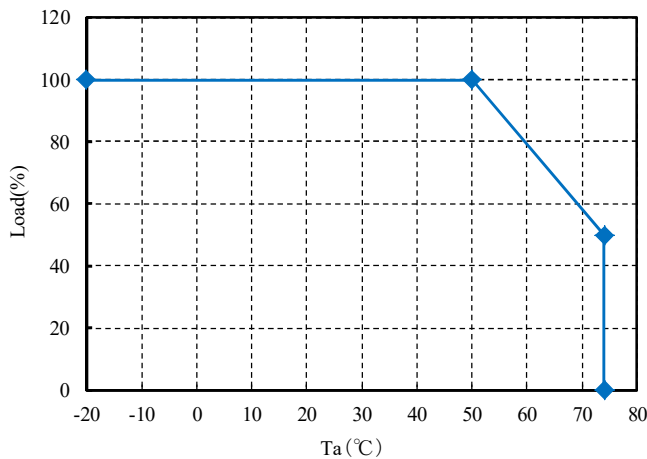

◆ Mounting (A) - (E)

Ta (°C)	Load
	Mounting (A) - (E)
-20 - 50	100% (20A)
74	50% (10A)

(2) Forced Air Cooling (Wind velocity $\geq 1.4\text{m/s}$)

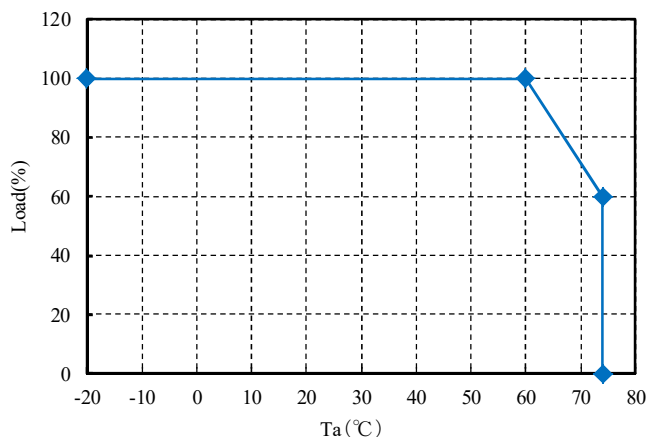

◆ Mounting (A) - (E)

Cooling : Wind velocity $\geq 1.4\text{m/s}$

Ta (°C)	Load
	Mounting (A) - (E)
-20 - 60	100% (20A)
74	60% (12A)

Please use Output (Input and Output Current) within the derating range.

When using the Forced Air Cooling, the entire component must be cooled.

For this product, the derating range for convection cooling is different from that for forced air cooling.

Please confirm specifications, and be careful.

6-3. Mounting Method

Insert the spacer (Max ϕ 6) of height more than 6mm to lift the unit. And use all 4 mounting holes for the product installation. The vibration spec is specified under this mounting condition.

- (1) Mounting Holes size
- 4 holes ϕ 3.5mm

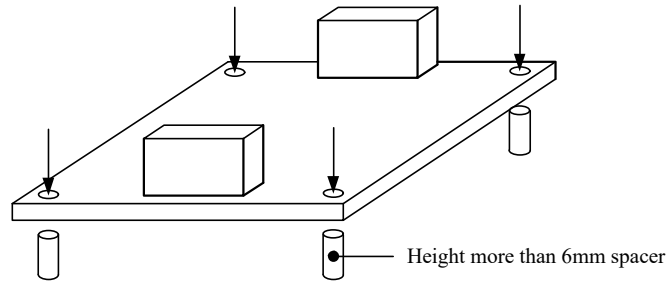

Allowable mounting area by metal spacer is figure below.

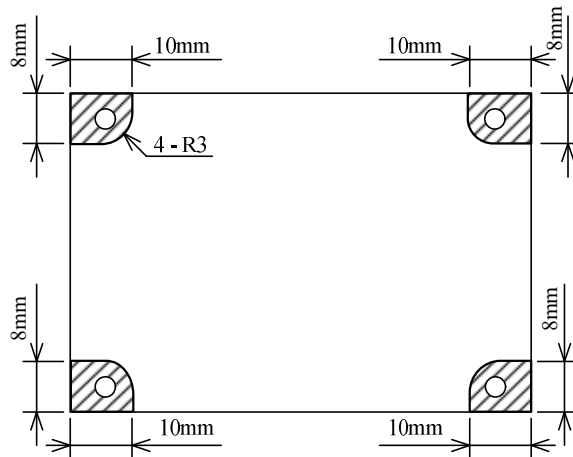

If the space is not enough, the specification of isolation and withstand will not be satisfied. Take the space in this product surroundings and the upper area of components to keep enough for convection cooling.

- (2) Condition to meet Isolation & Withstand Voltage standard
- Keep 4mm space from the surfaces and sides of PCB.
- Especially, 6mm space is necessary from the solder surface.

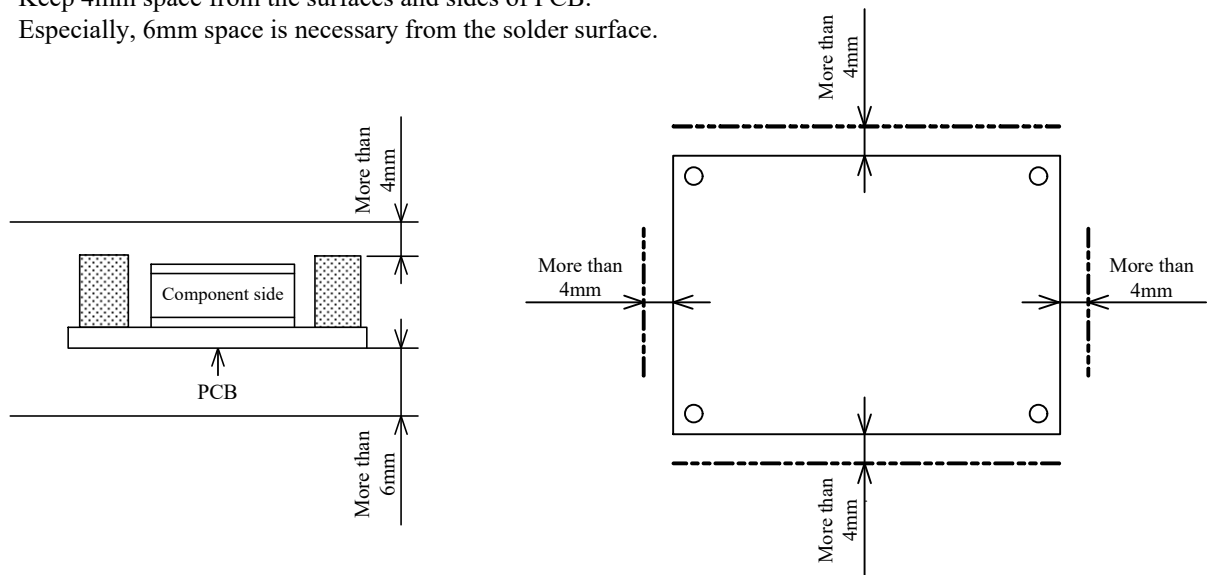

(3)Earth mounting hole \perp

The Earth mounting hole \perp to the Protective earth terminal of the equipment. The Earth mounting hole \perp must be connected to the Chassis (Conductor) by Metal spacer. If not, noise susceptibility will decrease.

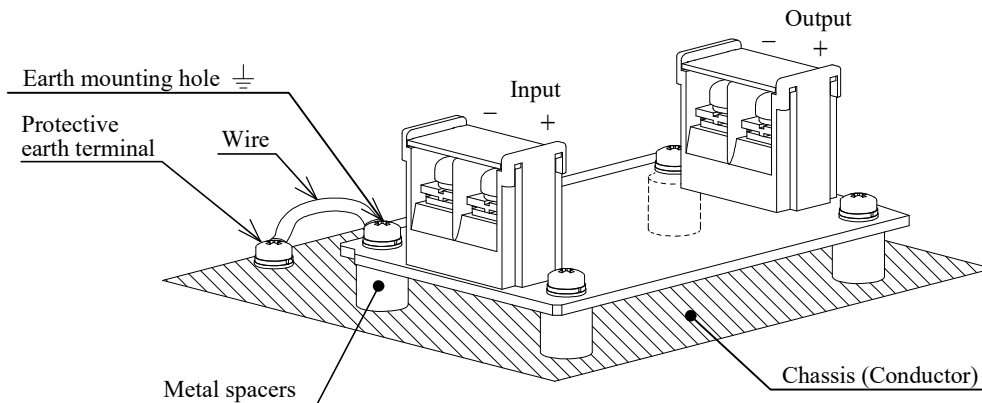

7. Wiring Method

- (1)The input line and output load line shall be separated each other and twisted individually to improve noise.
- (2)Use all lines as thick and short as possible to made lower impedance.
- (3)The recommended wire type :

Wire Size		Allowable Current (A)
(AWG)	(mm ²)	
20	0.52	5
18	0.82	7
16	1.3	10
14	2.1	20
12	3.3	25

8. Before concluding that the unit is at fault...

- (1)Check if the rated input voltage is connected.
- (2)Check if the wiring of input and output is correct.
- (3)Check if the wire size is not too thin.
- (4)Check if the input current and output power dose not over specification.
- (5)Check if the contact resistance value of the terminal is not high.

9. Warranty Period

This product is warranted for a period of 5 years from the date of shipment.
 For damages occurring at normal operation within this warranty period, repair is free of charge.
 Please read the General Safety Instruction before using the products.