



TDK FLASH STORAGE CATALOGUE 2018



Awarded "Excellent Supplier 2017H1 (Storage Cards)" and "2017 Outstanding Quality" by Huawei Technologies Co., Ltd.

TDK Corporation
Flash Memory Applied Device Business Div.
<https://product.tdk.com/en/>



※本カタログは環境に配慮した資材と工場で製造されています。
印刷には、水なし印刷、森林認証紙 (FSC) を採用しています。



MEDICAL

ENERGY

LIFE &
ENTERTAINMENT

INFRASTRUCTURE

FA

ICT

SMART INFRA : STORAGE

TDK-powered SSD solutions. Excelling anytime, anyplace, at any jobsite.
Manufacturing, transport, IT, financial, medical...
TDK flash storage devices help get the job right, in all domains.
On the land, across the seas, in the skies—24/7. SSD solutions from TDK,
securing your jobsite again, today.

SMART STORAGE, SMART FUTURE

TDK has developed the NAND-type flash memory controllers “GBDriver” series realizing high speed access while securing data reliability. TDK has also developed Solid State Drives (SSDs) combining GBDriver series inside, ideal solution for embedded systems.

CONTENTS

03

GBDriver

07

Product Features

11





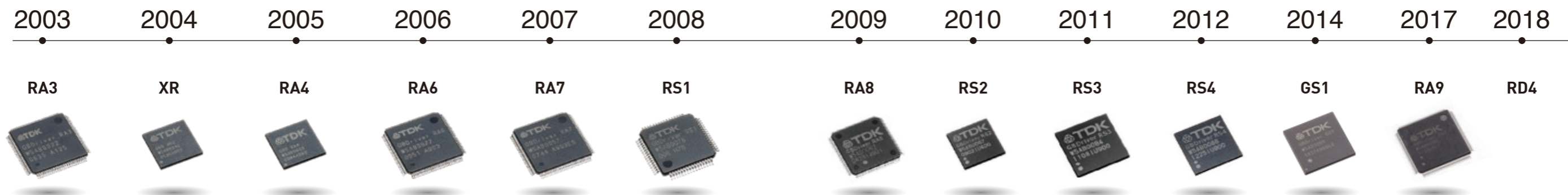

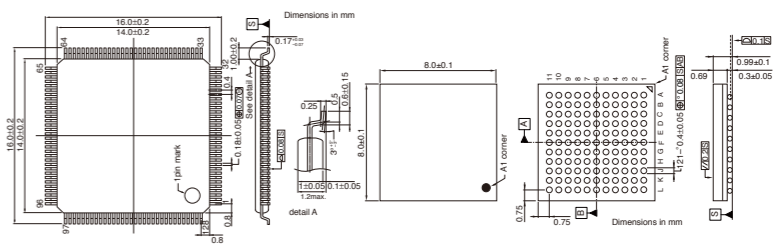

Product Lineup

GBDriver

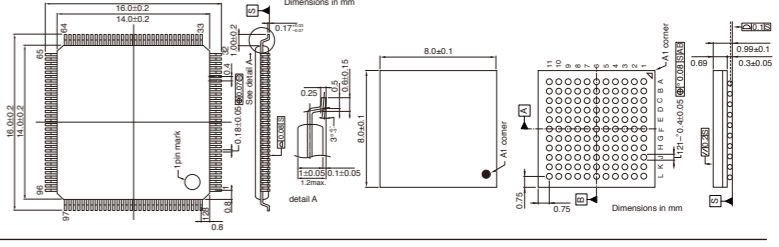

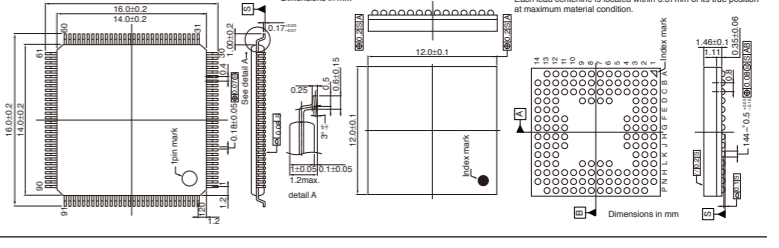
Flash Memory Controller IC GBDriver series

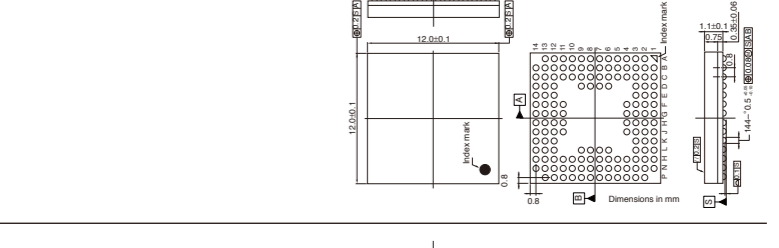
Over 50million shipments

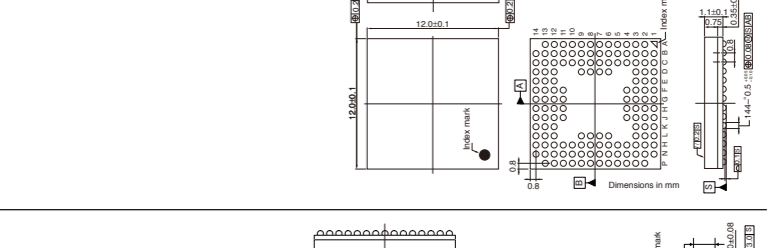
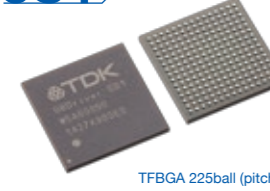
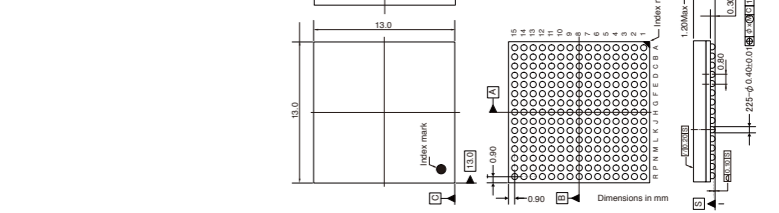
Product NAME	HOST INTERFACE					FLASH MEMORY INTERFACE										Clock Freq. MHz	Power Spec	Operating Temperature	Package, Shapes & Dimensions
	PCMCIA ATA	Compact Flash	IDE	Direct Bus Connect	Inter-face	Access Cycle	2K Page SLC	4K Page SLC	8K Page SLC	16K Page pSLC	8K Page MLC	16K Page MLC	Smallest Capacity	Largest Capacity	-CS				
RA8  TQFP 128pin (pitch 0.40mm) VFBGA 121ball (pitch 0.65mm)		4.1	PIO6 — MDMA4 — UDMA6	○	133 MByte/sec	30ns	○	○				1Gb	32Gb	8	80pF	33	I/O 3.3V Core 1.5V	-40 to +85°C	
RA9  TQFP 128pin (pitch 0.40mm) VFBGA 121ball (pitch 0.65mm)		4.1	PIO6 — MDMA4 — UDMA6	○	133 MByte/sec	30ns	○	○	○			1Gb	32Gb	8	80pF	33	I/O 3.3V Core 1.2V	-40 to +85°C	
RS2  TQFP 120pin (pitch 0.40mm) VFBGA 144ball (pitch 0.80mm)		SATA 1.5Gbps/3.0Gbps			30ns	○	○					1Gb	32Gb	16	100pF	30	I/O 3.3V Core 1.0V	-40 to +85°C	
RS3  VFBGA 144ball (pitch 0.80mm)		SATA 1.5Gbps/3.0Gbps			30ns	○	○	○				2Gb	128Gb	16	100pF	30	I/O 3.3V Core 1.0V	-40 to +85°C	
RS4  VFBGA 144ball (pitch 0.80mm)		SATA 1.5Gbps/3.0Gbps			30ns		○	○	○	○		4Gb	512Gb	16	100pF	30	I/O 3.3V Core 1.2V	-40 to +85°C	
GS1  TFBGA 225ball (pitch 0.90mm)		SATA 1.5Gbps/3.0Gbps/6.0Gbps			30ns		○	○	○	○		8Gb	512Gb	16	100pF	25	I/O 3.3V Core 1.2V	-40 to +85°C	

Download compatibility list of Flash Memories. <http://tdk.jp/fs-compatibility>

Power fault tolerance

If power fail occurs in writing a new data, SSDs will lose not only the new data itself but also other data when coping preceding and succeeding data .

TDK SSDs have 2 countermeasures.

Countermeasures No.1

First by GBDriver algorithm. GBDriver keeps the original data until coping is completed and will not employ any data of incomplete copy.

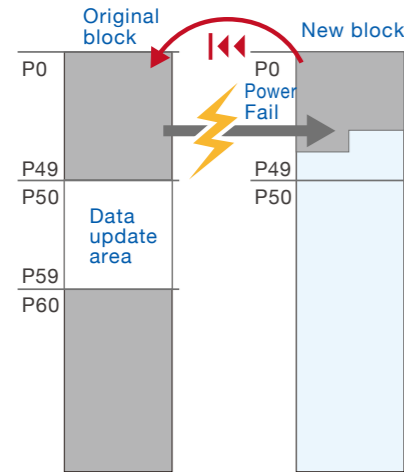

Power shutdown test

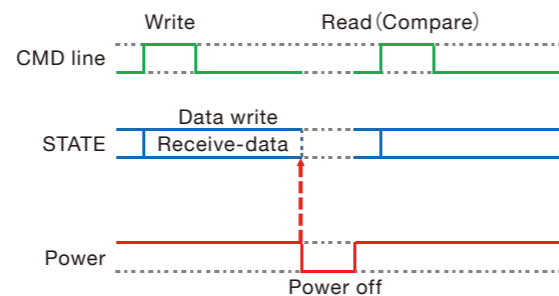

①SD Memory Cards, Power shutdown test result

	TDK	A	B
Writing data sectors	166,049,542	27,296,954	5,791,942
Power off cycles	15,989	7,155	753
Data errors	0 (0.00%)	2 (0.03%)	1 (0.13%)

②SSDs, Power shutdown test result

	TDK	A	B
Writing data sectors	2837558584	3966531026	2015419396
Power off cycles	677	946	481
Data errors	0 (0.00%)	859 (91%)	68 (14%)

TDK SSDs secure data reliability in sudden power fail.

Countermeasures No.2

Second, TDK SSDs (except for SD memory cards/microSD memory cards/eSSDs) employ power back up circuit inside, they are free from ECC errors.

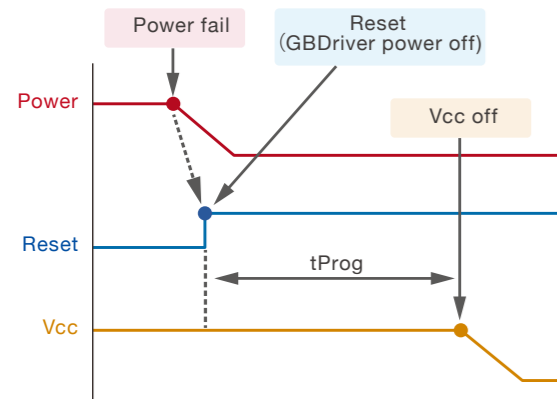

SSDs optimized for customers

Customers can choose flash types from SLC, MLC and pSLC.

		SLC	pSLC	MLC
Endurance [P/E per block]		100k	20k	3k
Performance (Read/Write) *CAE1B [MB/s]		305/105 (16GB)	340/105 (32GB~)	265/75 (32GB/64GB)
Cost [MLC=1]		x10	x2	x1

Endurance by Flash Type: 768 blocks (24block×32chips[lots])

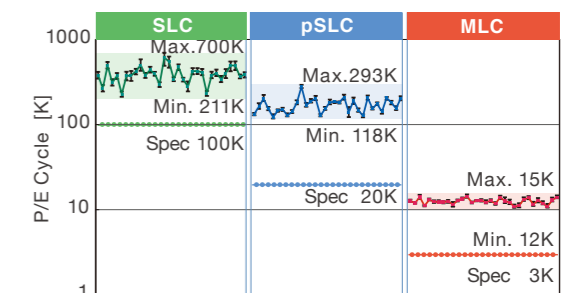

Data retention

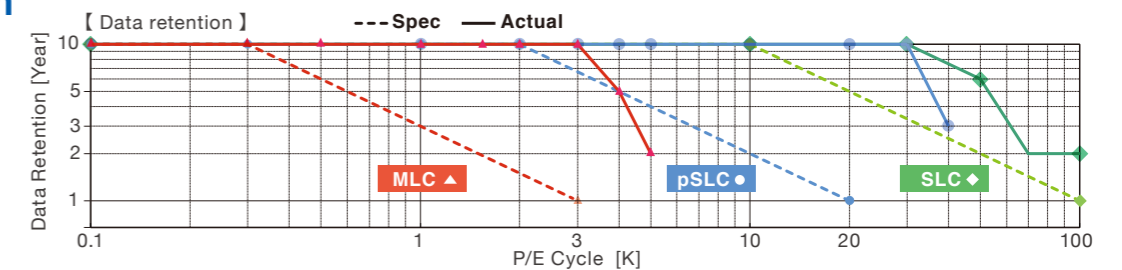

Cyclic auto refresh function secures data retention.

TDK SSDs are equipped with a cyclic auto refresh function which automatically checks data and recovers errors by ECC. "Refresh" are executed on every booting and 24hours.

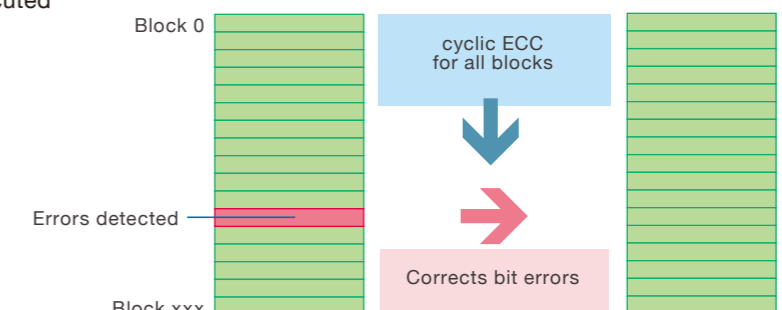

TDK SMART SWAP

Longevity and ECO Friendly

In order to extend the longevity, our products execute “TDK global static wear leveling (TDK SMART SWAP)” and level P/E count of NAND flash cells(blocks) efficiently. Storages replacement is Low frequency and it is Lower TCO (Total Cost of Ownership).

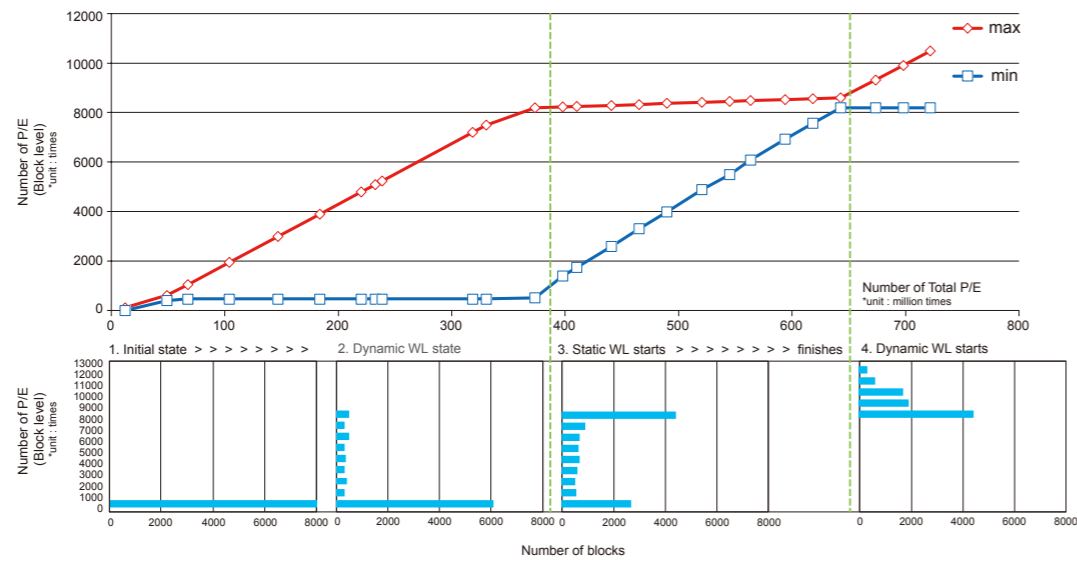

TDK global static wear leveling function (TDK SMART SWAP)

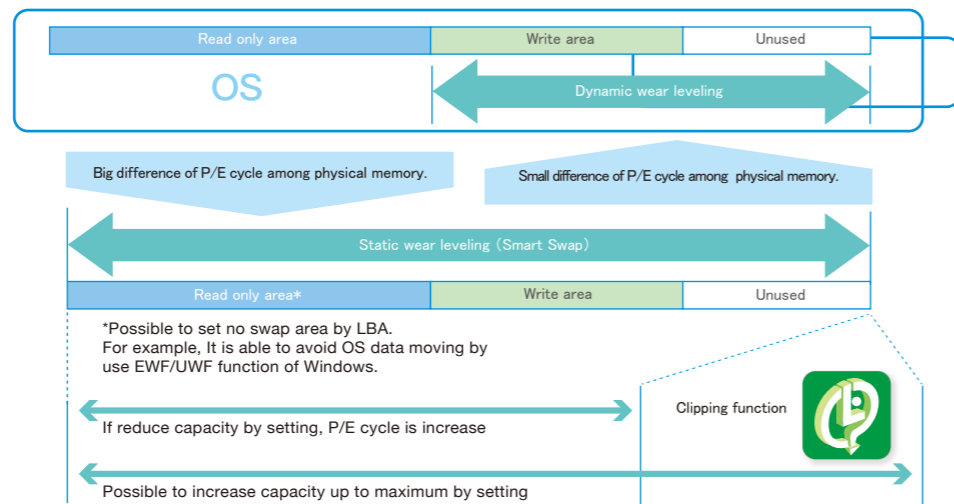

Clipping function (Number of sector setting)

Possible to adjust number of sector for user data area in unit of a sector.

TDK SMART (Flash storage life monitor – Endurance analysis program)

TDK SMART provides various information(following) and could predict storages life.

- Number of flash memory chips, number of blocks
- Number of total P/E cycles,Number of highest/lowest P/E cycles among blocks
- Total P/E cycles for all blocks(in a 10-level histogram)
- Memory usage[%], Life indicator[%]

Tools for Windows OS are Available for download on TDK web site. <https://product.tdk.com/info/en/products/flash-storage/flash-storage/tdksmart.html>
*If you need command operation, please contact us.

Main Window

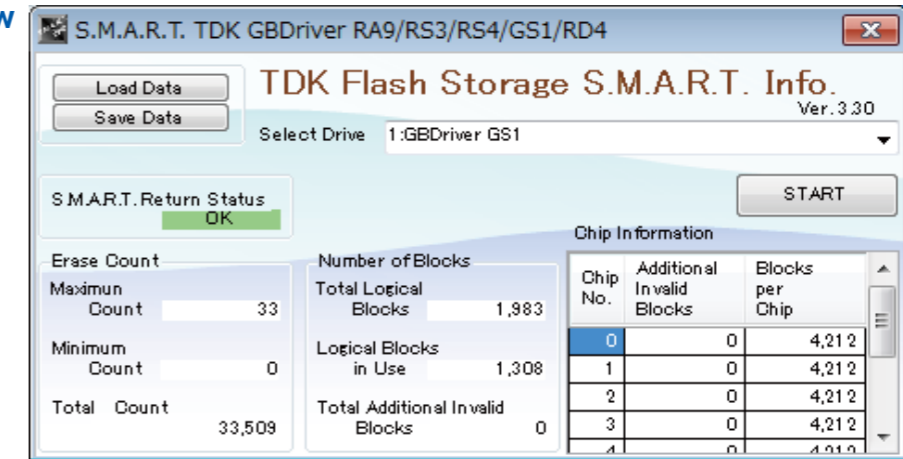

Erase Count Histogram

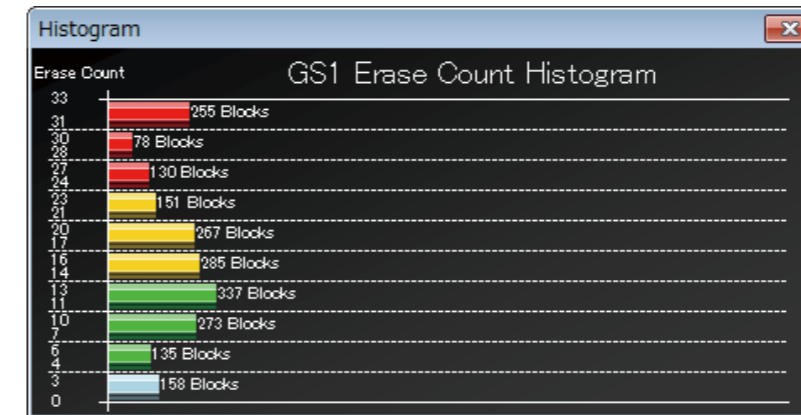

Memory Usage

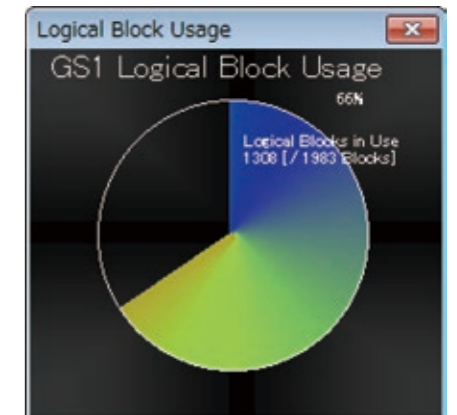

Memory Usage [%]

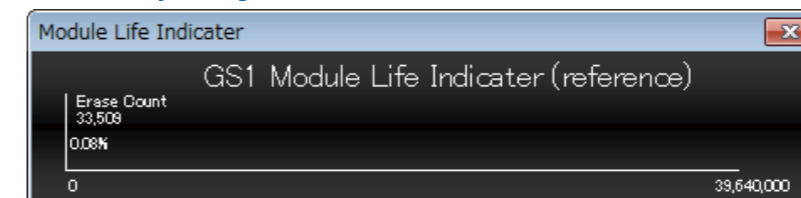

Compact Flash™ / 2.5" PATA SSD

CFE9D



SDE9D



GENERAL INFORMATION

TYPE	CompactFlash™	2.5 inch PATA SSD
INTERFACE	PCMCIA/IDE	IDE
DATA TRANSFER MODE	UDMA0-6, MDMA0-4 & PIO0-6	UDMA0-6, MDMA0-4 & PIO0-6
CONNECTOR	CFC Type I	44PIN
OUTLINE DIMENSIONS	36.4 x 42.8 x 3.3 mm	100 x 69.85 x 9.5 mm
SERIES	CFE9D	SDE9D
CONTROLLER TYPE	TDK GBDriver RA9	
FLASH TYPE	SLC	SLC
DENSITY RANGE	128 MB - 32 GB	1 GB - 64 GB
DATA RETENTION	10 years @ life begin-10% 1 year @ life end	
ENDURANCE ENTERPRISE WL	128 MB ~ 4 GB: 50,000 P/E Cycles 8 GB ~ 32 GB: 100,000 P/E Cycles *Flash Block Level	1 GB ~ 4 GB: 50,000 P/E Cycles 8 GB ~ 32 GB: 100,000 P/E Cycles *Flash Block Level

TEMPERATURE

OPERATING TEMPERATURE	Commercial: 0°C to +70°C Industrial: -40°C to +85°C
STORAGE TEMPERATURE	Commercial: -25°C to +85°C Industrial: -40°C to +85°C

PERFORMANCE

Read (max.)	50 MByte/sec
Write (max.)	35 MByte/sec

ROBUSTNESS

MTBF	≥ 2,500,000 hours	≥ 2,000,000 hours
SHOCK	1000G, 0.5ms	1500G, 1.0ms
VIBRATION	15G, 10-500Hz	20G, 10-2000Hz
HUMIDITY	0 to 90 % RH (No condensation)	

ELECTRICAL DATA

VOLTAGE	3.3 V ± 5 % / 5 V ± 10 %	5 V ± 10 %
POWER CONSUMPTION	- Single mode UDMA Read Write: 145mA @ 3.3V / 85mA @ 5.0V - 2ch mode UDMA Read Write: 220mA @ 3.3V / 130mA @ 5.0V - Stand-by: 10mA @ 3.3V / 10mA @ 5.0V	- Single mode UDMA Read Write: 80mA - 2ch mode UDMA Read Write: 135mA - Stand-by: 5mA

FEATURE LIST

FEATURES & TOOLS	- In-House Designed Controller (HW/FW) - Power Fail Data Safety - Power Back-up Circuit - Global static wear leveling - SMART - TRIM	- In-House Designed Controller (HW/FW) - Power Fail Data Safety - Power Back-up Circuit - Global static wear leveling - SMART - TRIM
PART NUMBER	CFE9DxxxxTxxxB00EAA0	SDE9DxxxxTxxxB00ESA0

CFast™

CAE3B



CAE1B



GENERAL INFORMATION

TYPE	CFast™		
INTERFACE	Serial ATA Revision 2.6	Serial ATA Revision 3.1	
DATA TRANSFER MODE	SATA 1.5Gbps, 3.0Gbps	SATA 1.5Gbps, 3.0Gbps, 6.0Gbps	
CONNECTOR	CFast™ Type I		
OUTLINE DIMENSIONS	36.4 x 42.8 x 3.6 mm		
SERIES	CAE3B	CAE1B	
CONTROLLER TYPE	TDK GBDriver RS3	TDK GBDriver GS1	
FLASH TYPE	SLC	SLC	pSLC/MLC
DENSITY RANGE	512 MB - 8 GB	16 GB - 64 GB	pSLC: 16 GB - 128 GB MLC: 32 GB - 256 GB
DATA RETENTION	10 years @ life begin-10% 1 year @ life end		
ENDURANCE ENTERPRISE WL	512 MB ~ 8 GB: 50,000 P/E Cycles *Flash Block Level	100,000 P/E Cycles *Flash Block Level	pSLC: 20,000 P/E Cycles MLC: 3,000 P/E Cycles *Flash Block Level

TEMPERATURE

OPERATING TEMPERATURE	Commercial: 0°C to +70°C Industrial: -40°C to +85°C
STORAGE TEMPERATURE	Commercial: -25°C to +85°C Industrial: -40°C to +85°C

PERFORMANCE

Read (max.)	105 MByte/sec	340 MByte/sec	pSLC: 345 MByte/sec MLC: 295 MByte/sec
Write (max.)	60 MByte/sec	105 MByte/sec	pSLC: 145 MByte/sec MLC: 75 MByte/sec

ROBUSTNESS

MTBF	≥ 2,000,000 hours	≥ 2,000,000 hours
SHOCK	1500G, 0.5ms	
VIBRATION	20G, 10-2000Hz	
HUMIDITY	0 to 90 % RH (No condensation)	

ELECTRICAL DATA

VOLTAGE	3.3 V ± 5 %	
POWER CONSUMPTION	- Single mode Read Write: 125mA max. - 2ch mode Read Write: 215mA max. - 4ch mode Read Write: 365mA max. - Slumber: less than 50mA	- Read: 385mA max. - Write: 370mA max. - Slumber: less than 100mA

FEATURE LIST

FEATURES & TOOLS	- In-House Designed Controller (HW/FW) - Power Fail Data Safety - Power Back-up Circuit - Global static wear leveling - SMART - NCQ, TRIM - AES 128bit encryption	- In-House Designed Controller (HW/FW) - Power Fail Data Safety - Power Back-up Circuit - Global static wear leveling - SMART - NCQ, TRIM - AES 128/256bit encryption	
PART NUMBER	CAE3BxxxxTxxxB00EAA0	CAE1BxxxxTXDxB00EAA0	CAE1BxxxxTxDb00EAA0

2.5" SATA SSD



GENERAL INFORMATION

TYPE	2.5 inch SATA SSD (9mm)		2.5 inch SATA SSD (7mm)	
INTERFACE	Serial ATA Revision 3.1			
DATA TRANSFER MODE	SATA 1.5Gbps, 3.0Gbps, 6.0Gbps			
CONNECTOR	15 + 7 pin Serial ATA			
OUTLINE DIMENSIONS	100.0 x 69.84 x 9.5 mm		100.0 x 69.85 x 7.0 mm	
SERIES	SDE1B			
CONTROLLER TYPE	 TDK GBDriver GS1			
FLASH TYPE	SLC	pSLC/MLC	SLC	pSLC/MLC
DENSITY RANGE	16 GB - 128 GB	pSLC:16GB-256GB MLC:32GB-512GB	16 GB - 128 GB	pSLC:16GB-256GB MLC:32GB-512GB
DATA RETENTION	10 years @ life begin-10% 1 year @ life end			
ENDURANCE ENTERPRISE WL	100,000 P/E Cycles *Flash Block Level	pSLC:20,000P/E Cycles MLC:3,000P/E Cycles *Flash Block Level	100,000 P/E Cycles *Flash Block Level	pSLC:20,000P/E Cycles MLC:3,000P/E Cycles *Flash Block Level

TEMPERATURE

OPERATING TEMPERATURE	Commercial: 0°C to +70°C Industrial: -40°C to +85°C			
STORAGE TEMPERATURE	Commercial: -25°C to +85°C Industrial: -40°C to +85°C			

PERFORMANCE

Read (max.)	420 MByte/sec	pSLC:430MByte/sec MLC:365MByte/sec	420 MByte/sec	pSLC:430MByte/sec MLC:365MByte/sec
Write (max.)	305 MByte/sec	pSLC:325MByte/sec MLC:235MByte/sec	305 MByte/sec	pSLC:325MByte/sec MLC:235MByte/sec

ROBUSTNESS

MTBF	≥ 2,000,000 hours
SHOCK	1,000G,1.0ms
VIBRATION	20G,10-2000Hz
HUMIDITY	0 to 90 % RH (No condensation)

ELECTRICAL DATA

VOLTAGE	5 V ± 10 %
POWER CONSUMPTION	- Read: 320mA max. - Write: 600mA max. - Slumber: less than 100mA

FEATURE LIST

FEATURES & TOOLS	- In-House Designed Controller (HW/FW) - Power Fail Data Safety - Power Back-up Circuit - Global static wear leveling - SMART - NCQ, TRIM - AES 128/256bit encryption
PART NUMBER	SDE1BxxxxTXxxB00ESA0 SDE1BxxxxTxxxB00ESA0 SDE1BxxxxTXxxBA0ESA0 SDE1BxxxxTxxxBA0ESA0

Half Slim



GENERAL INFORMATION

TYPE	Half Slim	
INTERFACE	Serial ATA Revision 3.1	
DATA TRANSFER MODE	SATA 1.5Gbps, 3.0Gbps, 6.0Gbps	
CONNECTOR	15 + 7 pin Serial ATA	
OUTLINE DIMENSIONS	54 x 39 mm	
SERIES	SHE1B	
CONTROLLER TYPE	 TDK GBDriver GS1	
FLASH TYPE	SLC	pSLC/MLC
DENSITY RANGE	16 GB - 128 GB	pSLC:16GB-256GB MLC:32GB-512GB
DATA RETENTION	10 years @ life begin-10% 1 year @ life end	
ENDURANCE ENTERPRISE WL	100,000 P/E Cycles *Flash Block Level	pSLC:20,000P/E Cycles MLC:3,000P/E Cycles *Flash Block Level

TEMPERATURE

OPERATING TEMPERATURE	Commercial: 0°C to +70°C Industrial: -40°C to +85°C	
STORAGE TEMPERATURE	Commercial: -25°C to +85°C Industrial: -40°C to +85°C	

PERFORMANCE

Read (max.)	340 MByte/sec	pSLC:400 MByte/sec MLC:320 MByte/sec
Write (max.)	115 MByte/sec	pSLC:165 MByte/sec MLC:75 MByte/sec

ROBUSTNESS

MTBF	≥ 2,000,000 hours
SHOCK	1500G,0.5ms
VIBRATION	20G,10-2000Hz
HUMIDITY	0 to 90 % RH (No condensation)

ELECTRICAL DATA

VOLTAGE	5 V ± 10 %
POWER CONSUMPTION	- Read: 250mA max. - Write: 270mA max. - Slumber: less than 100mA

FEATURE LIST

FEATURES & TOOLS	- In-House Designed Controller (HW/FW) - Power Fail Data Safety - Power Back-up Circuit - Global static wear leveling - SMART - NCQ, TRIM - AES 128/256bit encryption
PART NUMBER	SHE1BxxxxTXDxB00SSA0 SHE1BxxxxTxDxB00SSA0

mSATA

SME3B



SME1B



GENERAL INFORMATION

TYPE	mSATA		
INTERFACE	Serial ATA Revision 2.6	Serial ATA Revision 3.1	
DATA TRANSFER MODE	SATA 1.5Gbps, 3.0Gbps	SATA 1.5Gbps, 3.0Gbps, 6.0Gbps	
CONNECTOR	52 pin. Edge		
OUTLINE DIMENSIONS	50.8 x 29.85 mm		
SERIES	SME3B	SME1B	
CONTROLLER TYPE	TDK GBDriver RS3	TDK GBDriver GS1	
FLASH TYPE	SLC	SLC	pSLC/MLC
DENSITY RANGE	512 MB - 8 GB	16 GB - 64 GB	pSLC:16 GB - 128 GB MLC:32 GB - 256 GB
DATA RETENTION	10 years @ life begin-10% 1 year @ life end		
ENDURANCE ENTERPRISE WL	512 MB ~ 8 GB:50,000 P/E Cycles *Flash Block Level	100,000 P/E Cycles *Flash Block Level	pSLC:20,000 P/E Cycles MLC:3,000 P/E Cycles *Flash Block Level

TEMPERATURE

OPERATING TEMPERATURE	Commercial:0°C to +70°C Industrial:-40°C to +85°C
STORAGE TEMPERATURE	Commercial:-25°C to +85°C Industrial:-40°C to +85°C

PERFORMANCE

Read (max.)	105 MByte/sec	340 MByte/sec	pSLC:345 MByte/sec MLC:295 MByte/sec
Write (max.)	60 MByte/sec	105 MByte/sec	pSLC:145 MByte/sec MLC:75 MByte/sec

ROBUSTNESS

MTBF	≥ 2,000,000 hours	≥ 2,000,000 hours
SHOCK	1500G,0.5ms	
VIBRATION	20G,10-2000Hz	
HUMIDITY	0 to 90 % RH (No condensation)	

ELECTRICAL DATA

VOLTAGE	3.3 V ± 5 %	
POWER CONSUMPTION	<ul style="list-style-type: none"> - Single mode Read Write: 125mA max. - 2ch mode Read Write: 215mA max. - 4ch mode Read Write: 365mA max. - Slumber: less than 50mA 	<ul style="list-style-type: none"> - Read:385mA max. - Write:370mA max. - Slumber:less than 100mA

FEATURE LIST

FEATURES & TOOLS	<ul style="list-style-type: none"> - In-House Designed Controller (HW/FW) - Power Fail Data Safety - Global static wear levelin - SMART - NCQ, TRIM - AES 128bit encryption 	<ul style="list-style-type: none"> - In-House Designed Controller (HW/FW) - Power Fail Data Safety - Power Back-up Circuit - Global static wear leveling - SMART - NCQ, TRIM - AES 128/256bit encryption 	
PART NUMBER	SME3BxxxxTxxxB00SAA0	SME1BxxxxTXDxB00SAA0	SME1BxxxxTxDxB00SAA0

M.2

SNE1B:2242



SNE1B:2280



GENERAL INFORMATION

TYPE	M.2 2242		M.2 2280	
INTERFACE	Serial ATA Revision 3.1			
DATA TRANSFER MODE	SATA 1.5Gbps, 3.0Gbps, 6.0Gbps			
CONNECTOR	75 pin. Edge B & M key			
OUTLINE DIMENSIONS	22 x 42 mm		22 x 80 mm	
SERIES	SNE1B			
CONTROLLER TYPE	TDK GBDriver GS1			
FLASH TYPE	SLC	pSLC/MLC	SLC	pSLC/MLC
DENSITY RANGE	16 GB - 64 GB	pSLC:16 GB - 128 GB MLC:32 GB - 256 GB	16 GB - 128 GB	pSLC:16 GB - 256 GB MLC:32 GB - 512 GB
DATA RETENTION	10 years @ life begin-10% 1 year @ life end			
ENDURANCE ENTERPRISE WL	100,000 P/E Cycles *Flash Block Level	pSLC:20,000P/ECycles MLC:3,000P/ECycles *Flash Block Level	100,000 P/E Cycles *Flash Block Level	pSLC:20,000P/ECycles MLC:3,000P/ECycles *Flash Block Level

TEMPERATURE

OPERATING TEMPERATURE	Commercial: 0°C to +70°C Industrial: -40°C to +85°C
STORAGE TEMPERATURE	Commercial: -25°C to +85°C Industrial: -40°C to +85°C

PERFORMANCE

Read (max.)	340 MByte/sec	pSLC:345 MByte/sec MLC:295 MByte/sec	340 MByte/sec	pSLC:345 MByte/sec MLC:295 MByte/sec
Write (max.)	105 MByte/sec	pSLC:145 MByte/sec MLC:75 MByte/sec	105 MByte/sec	pSLC:145 MByte/sec MLC:75 MByte/sec

ROBUSTNESS

MTBF	≥ 2,500,000 hours			
SHOCK	1500G,0.5ms			
VIBRATION	20G,10-2000Hz			
HUMIDITY	0 to 90 % RH (No condensation)			

ELECTRICAL DATA

VOLTAGE	3.3 V ± 5 %			
POWER CONSUMPTION	<ul style="list-style-type: none"> - Read: 385mA max. - Write: 370mA max. - Slumber: less than 100mA 			

FEATURE LIST

FEATURES & TOOLS	<ul style="list-style-type: none"> - In-House Designed Controller (HW/FW) - Power Fail Data Safety - Power Back-up Circuit - Global static wear leveling - SMART - NCQ, TRIM - AES 128/256bit encryption 			
PART NUMBER	SNE1BxxxxTXDxB00SAA0	SNE1BxxxxTxDxB00SAA0	SNE1BxxxxTXDxBA0SAA0	SNE1BxxxxTXDxBA0SAA0

SD Card / Micro SD Card

MMRD4



MURD4



GENERAL INFORMATION

TYPE	SD MEMORY CARD (SD / SDHC)		microSD MEMORY CARD (SD / SDHC)	
INTERFACE	SD 3.0, UHS-I/Class 10 (SDHC) , Class 6 (SD)			
DATA TRANSFER MODE				
CONNECTOR	SD		microSD	
OUTLINE DIMENSIONS	32 x 24 x 2.1 mm		15 x 11 x 0.7 / 1 mm	
SERIES	MMRD4		MURD4	
CONTROLLER TYPE	TDK GBDriver RD4			
FLASH TYPE	SLC	pSLC	SLC	pSLC
DENSITY RANGE	512 MB - 32 GB	4 GB - 32 GB	512 MB - 2 GB	4 GB - 32 GB
DATA RETENTION	10 years @ life begin-10% 1 year @ life end			
ENDURANCE ENTERPRISE WL	512 MB - 2 GB:50,000 P/E Cycles 4 GB - 32 GB:100,000 P/E Cycles *Flash Block Level	20,000 P/E Cycles *Flash Block Level	50,000 P/E Cycles *Flash Block Level	20,000 P/E Cycles *Flash Block Level

TEMPERATURE

OPERATING TEMPERATURE	Commercial: -25°C to +85°C Industrial: -40°C to +85°C			
STORAGE TEMPERATURE	-40°C to +85°C			

PERFORMANCE

Read (max.)	75 MByte/sec	70 MByte/sec	75 MByte/sec	70 MByte/sec
Write (max.)	50 MByte/sec	67 MByte/sec	50 MByte/sec	67 MByte/sec

ROBUSTNESS

MTBF	≥ 3,000,000 hours		≥ 3,000,000 hours	
SHOCK	1000G,0.5ms			
VIBRATION	15G,10-2000Hz			
HUMIDITY	0 to 90 % RH (No condensation)			

ELECTRICAL DATA

VOLTAGE	2.7 ~ 3.6 V			
POWER CONSUMPTION	- Read: 100mA max. - Write: 100mA max. - Stand-by: 0.4mA			

FEATURE LIST

FEATURES & TOOLS	- In-House Designed Controller - Power Fail Data Safety - Global static wear leveling - SMART			
PART NUMBER	MMRD4xxxxVxxxA00AAA0		MURD4xxxxVxxxA00AAA0	

	CF CARD	SLC	CFE9D128MTPACB00EAA0 CFE9D256MTPACB00EAA0 CFE9D512MTNACB00EAA0 CFE9D001GTNACB00EAA0 CFE9D002GTNACB00EAA0 CFE9D004GTNACB00EAA0 CFE9D008GTNACB00EAA0 CFE9D008GTNACB00EAA0 CFE9D008GTNACB00EAA0 CFE9D016GTNACB00EAA0 CFE9D032GTNACB00EAA0	1) C:0~70°C >>> W:-40~85°C	
	PATA SSD	SLC	SDE9D001GTNACB00ESA0 SDE9D002GTNACB00ESA0 SDE9D004GTNACB00ESA0 SDE9D008GTNACB00ESA0 SDE9D016GTNACB00ESA0 SDE9D032GTNACB00ESA0 SDE9D064GTNACB00ESA0	1) C:0~70°C >>> W:-40~85°C	
	CFast	SLC	CAE3B512MTNACB00EAA0 CAE3B001GTNACB00EAA0 CAE3B002GTNACB00EAA0 CAE3B004GTNACB00EAA0 CAE3B008GTNACB00EAA0	1) C:0~70°C >>> W:-40~85°C	
		SLC	CAE1B016GTXDCB00EAA0 CAE1B032GTXDCB00EAA0 CAE1B064GTXDCB00EAA0	1) C:0~70°C >>> W:-40~85°C	
	CFast	pSLC	CAE1B016GTKDCB00EAA0 CAE1B032GTKDCB00EAA0 CAE1B064GTKDCB00EAA0 CAE1B128GTKDCB00EAA0	1) C:0~70°C >>> W:-40~85°C	
		MLC	CAE1B032GTFDCB00EAA0 CAE1B064GTFDCB00EAA0 CAE1B128GTFDCB00EAA0 CAE1B256GTFDCB00EAA0	1) C:0~70°C >>> W:-40~85°C 2) B,E:SATA Gen3(6Gbps) >>> D,F:SATA Gen2(3Gbps)	
	SATA SSD	SLC	SDE1B016GTXDCB00ESA0 SDE1B032GTXDCB00ESA0 SDE1B064GTXDCB00ESA0 SDE1B128GTXDCB00ESA0	1) C:0~70°C >>> W:-40~85°C 2) B,E:SATA Gen3(6Gbps) >>> D,F:SATA Gen2(3Gbps)	
		pSLC	SDE1B016GTKDCB00ESA0 SDE1B032GTKDCB00ESA0 SDE1B064GTKDCB00ESA0 SDE1B128GTKDCB00ESA0 SDE1B256GTKDCB00ESA0	1) C:0~70°C >>> W:-40~85°C 2) B,E:SATA Gen3(6Gbps) >>> D,F:SATA Gen2(3Gbps) 3) O:Case9.5mm >>> A:Case7mm	
	SATA SSD	MLC	SDE1B032GTFDCB00ESA0 SDE1B064GTFDCB00ESA0 SDE1B128GTFDCB00ESA0 SDE1B256GTFDCB00ESA0 SDE1B512GTFDCB00ESA0	1) C:0~70°C >>> W:-40~85°C 2) B,E:SATA Gen3(6Gbps) >>> D,F:SATA Gen2(3Gbps) 3) O:Type2242 >>> A:Type2280	

	Half Slim	SLC	SHE1B016GTXDCB00SSA0 SHE1B032GTXDCB00SSA0 SHE1B064GTXDCB00SSA0 SHE1B128GTXDCB00SSA0	1) C:0~70°C >>> W:-40~85°C	
		pSLC	SHE1B016GTKDCB00SSA0 SHE1B032GTKDCB00SSA0 SHE1B064GTKDCB00SSA0 SHE1B128GTKDCB00SSA0 SHE1B256GTKDCB00SSA0	1) C:0~70°C >>> W:-40~85°C	
	mSATA	SLC	SME3B512MTNACB00SSA0 SME3B001GTNACB00SSA0 SME3B002GTNACB00SSA0 SME3B004GTNACB00SSA0 SME3B008GTNACB00SSA0	1) C:0~70°C >>> W:-40~85°C	
		SLC	SME1B016GTXDCB00SSA0 SME1B032GTXDCB00SSA0 SME1B064GTXDCB00SSA0	1) C:0~70°C >>> W:-40~85°C	
	mSATA	pSLC	SME1B016GTKDCB00SSA0 SME1B032GTKDCB00SSA0 SME1B064GTKDCB00SSA0 SME1B128GTKDCB00SSA0	1) C:0~70°C >>> W:-40~85°C	
		MLC	SME1B032GTFDCB00SSA0 SME1B064GTFDCB00SSA0 SME1B128GTFDCB00SSA0 SME1B256GTFDCB00SSA0	1) C:0~70°C >>> W:-40~85°C 2) B,S:SATA Gen3(6Gbps) >>> D,R:SATA Gen2(3Gbps)	
	M.2	SLC	SNE1B016GTXDCB00SSA0 SNE1B032GTXDCB00SSA0 SNE1B064GTXDCB00SSA0 SNE1B128GTXDCB00SSA0	1) C:0~70°C >>> W:-40~85°C	
		pSLC	SNE1B016GTKDCB00SSA0 SNE1B032GTKDCB00SSA0 SNE1B064GTKDCB00SSA0 SNE1B128GTKDCB00SSA0 SNE1B256GTKDCB00SSA0	1) C:0~70°C >>> W:-40~85°C	
	M.2	MLC	SNE1B032GTFDCB00SSA0 SNE1B064GTFDCB00SSA0 SNE1B128GTFDCB00SSA0 SNE1B256GTFDCB00SSA0 SNE1B512GTFDCB00SSA0	1) C:0~70°C >>> W:-40~85°C 2) B,S:SATA Gen3(6Gbps) >>> D,R:SATA Gen2(3Gbps) 3) O:Type2242 >>> A:Type2280	

	SD	SLC	MMRD4512MVNACA00AAA0 MMRD4001GVNBACA00AAA0 MMRD4002GVNBACA00AAA0 MMRD4004GVYBACA00AAA0 MMRD4008GVYBACA00AAA0 MMRD4016GVYBACA00AAA0 MMRD4032GVYBACA00AAA0	1) C:-25~85°C >>> W:-40~85°C	
		pSLC	MMRD4004GVHACA00AAA0 MMRD4008GVJACA00AAA0 MMRD4016GVJACA00AAA0 MMRD4032GVJACA00AAA0	1) C:-25~85°C >>> W:-40~85°C	
	micro SD	SLC	MURD4512MVNACA00AAA0 MURD4001GVNBACA00AAA0 MURD4002GVNBACA00AAA0	1) C:-25~85°C >>> W:-40~85°C	
		pSLC	MURD4004GVHACA00AAA0 MURD4008GVHACA00AAA0 MURD4016GVHACA00AAA0 MURD4032GVHACA00AAA0	1) C:-25~85°C >>> W:-40~85°C	