

# CGA2B2NP02A121J050BA

TDK Item Description : CGA2B2NP02A121T\*\*\*\*



Equivalent C1005NP02A121J for Automotive

## Application & Main Feature

Automotive Grade ( High Temperature Application )

## Series

CGA2(1005) [EIA CC0402]

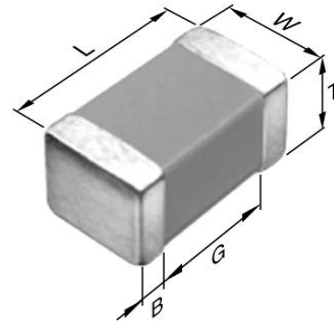

## Dimensions

L	1.00mm +/-0.05mm
W	0.50mm +/-0.05mm
T	0.50mm +/-0.05mm
B	0.10mm Min.
G	0.3mm Min.

## Temperature Characteristic

NP0 (-55 to 150 degC 0+/-30ppm/degC)

## Rated Voltage

2A (100Vdc)

## Capacitance

120pF

## Capacitance Tolerance

J (+/-5%)

## Q Factor

1000 Min.

## Insulation Resistance

10Gohm Min

## AEC-Q200

Yes

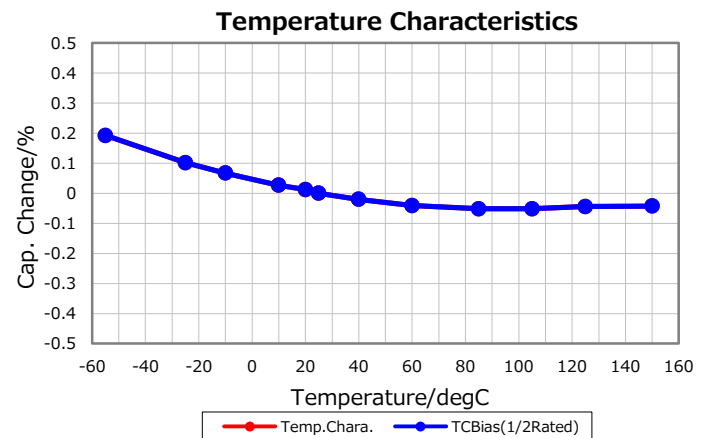
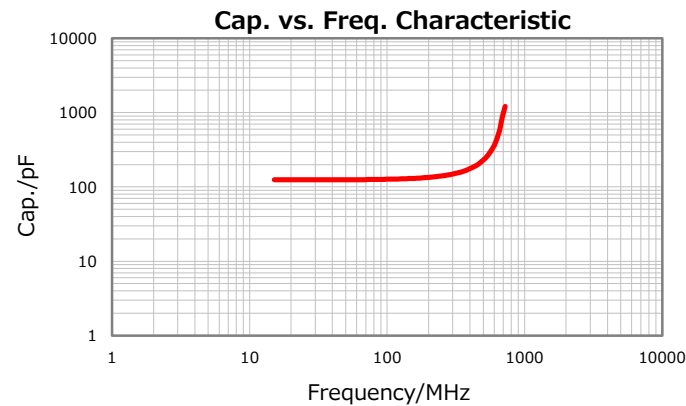
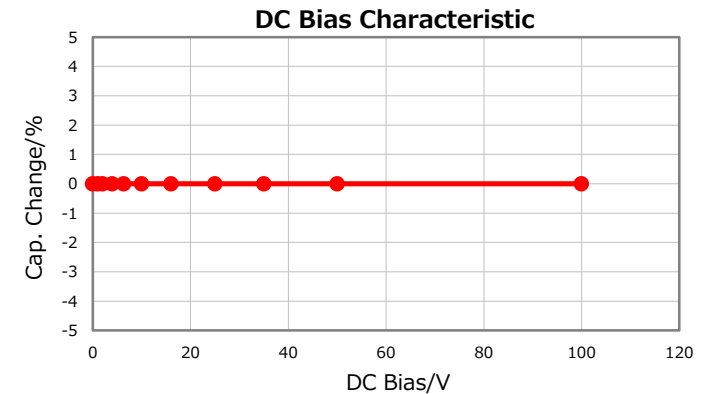
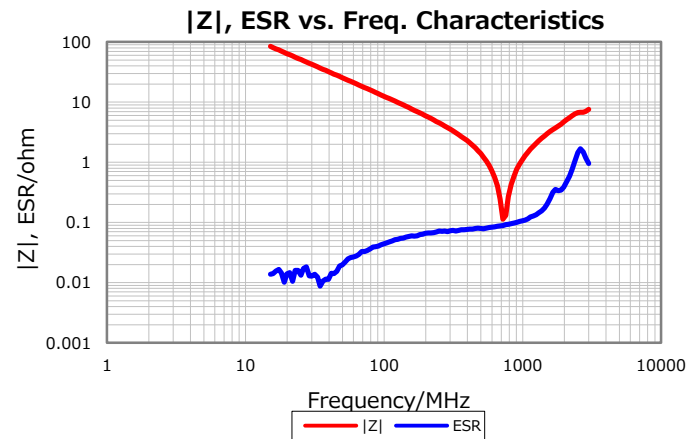

Characterization Sheet ( Multilayer Ceramic Chip Capacitors )



All specifications are subject to change without notice.