

CGA4J1X8L1H474K125AE

TDK item description : CGA4J1X8L1H474KT***S



Equivalent C2012X8L1H474K for Automotive

Application & Main Feature

Automotive grade (Soft termination)

Series

CGA4(2012) [EIA 0805]

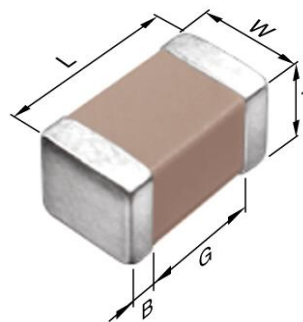

Dimensions

L	2.00+0.45/-0.20 mm
W	1.25+0.25/-0.20 mm
T	1.25+0.25/-0.20 mm
B	0.20 mm min.
G	0.50 mm min.

Temperature Characteristic

X8L (-55 to +150 degC, +15/-40%)

Rated Voltage

1H (50Vdc)

Capacitance

470nF

Capacitance Tolerance

K (±10%)

DF

5 % max.

Insulation Resistance

1063 Mohm min.

AEC-Q200

Yes

|Z|, ESR vs. Freq. Characteristics (Simulation data)

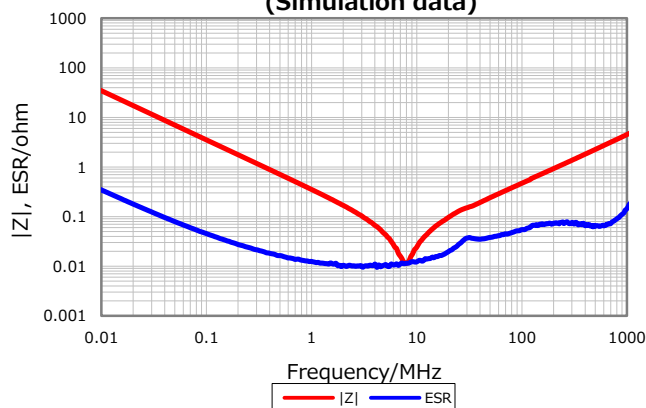

Cap. vs. Freq. Characteristic

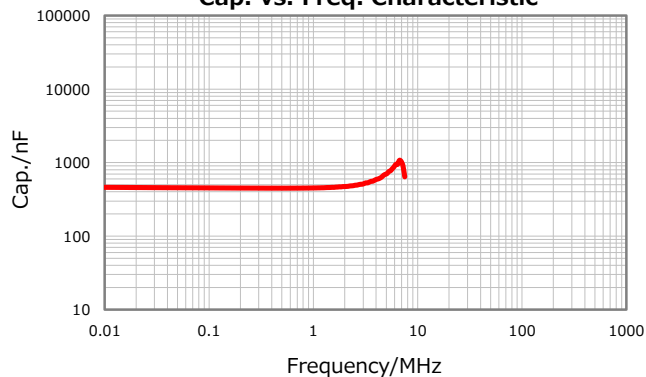

DC Bias Characteristic

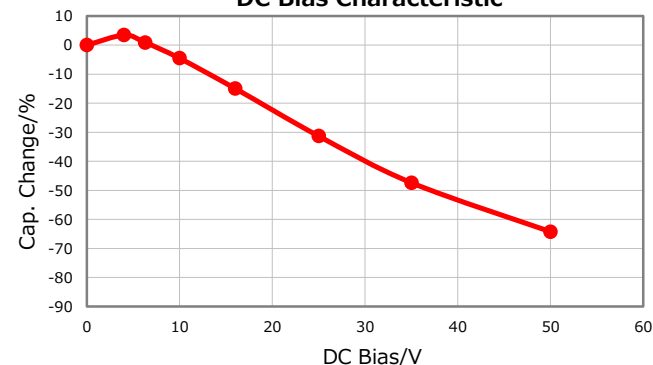

Temperature Characteristics

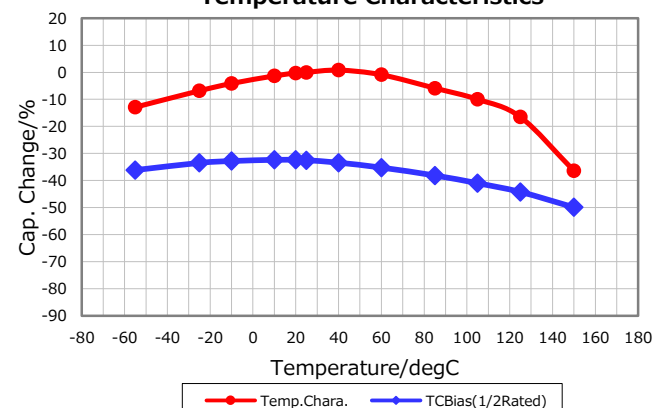

Ripple Temperature Rise Characteristics

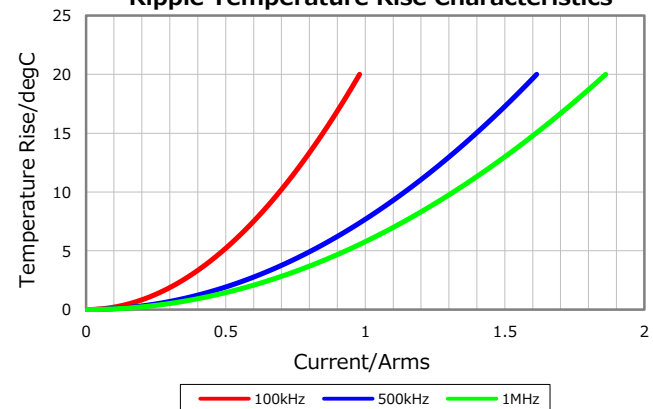

Characterization Sheet (Multilayer Ceramic Chip Capacitors)



All specifications are subject to change without notice.

June 28, 2020