

# CGA4J3X8R1E474M125AE

TDK Item Description : CGA4J3X8R1E474MT\*\*\*S



Equivalent C2012X8R1E474M for Automotive

## Application & Main Feature

Automotive Grade ( Soft Termination )

## Series

CGA4(2012) [EIA CC0805]

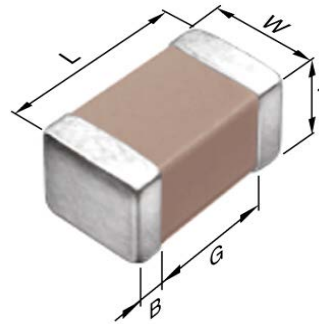

## Dimensions

L	2.00mm +0.45,-0.2mm
W	1.25mm +0.25,-0.2mm
T	1.25mm +0.25,-0.2mm
B	0.20mm Min.
G	0.50mm Min.

## Temperature Characteristic

X8R (-55 to 150 degC +/-15%)

## Rated Voltage

1E (25Vdc)

## Capacitance

470nF

## Capacitance Tolerance

M (+/-20%)

## Dissipation Factor

3% Max.

## Insulation Resistance

1.063Gohm Min

## AEC-Q200

Yes

**|Z|, ESR vs. Freq. Characteristics (Simulation Data)**

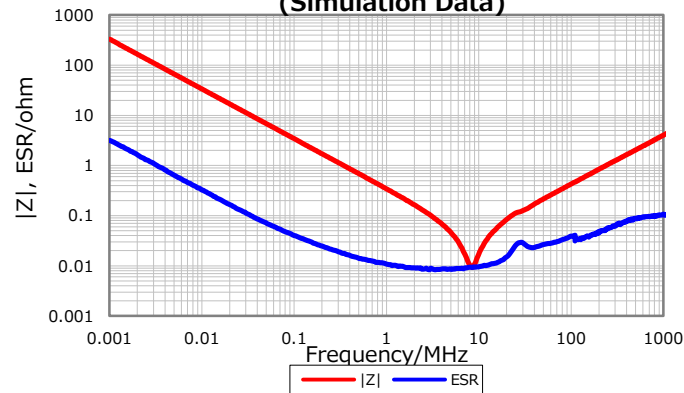

**Cap. vs. Freq. Characteristic**

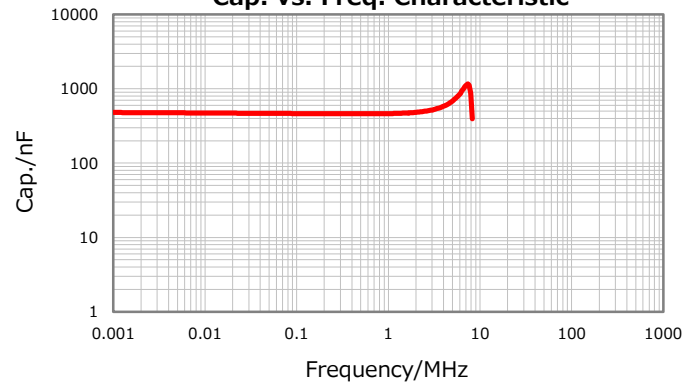

**DC Bias Characteristic**

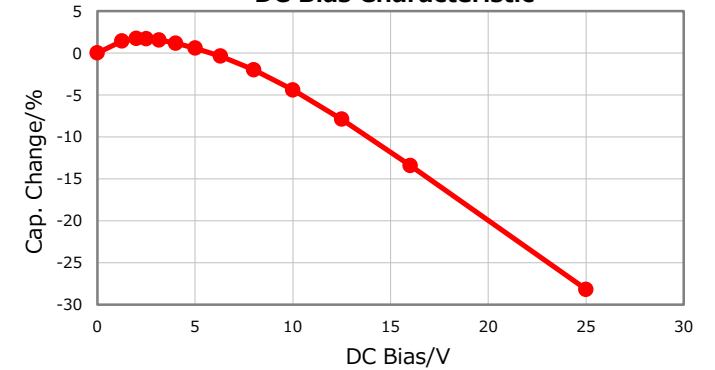

**Temperature Characteristics**

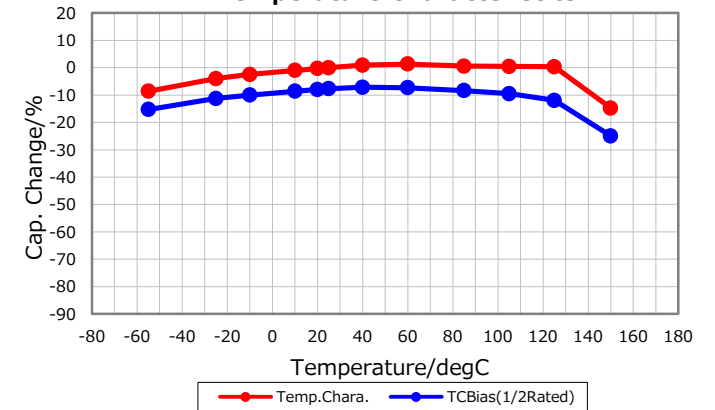

**Ripple Temperature Rise Characteristics**

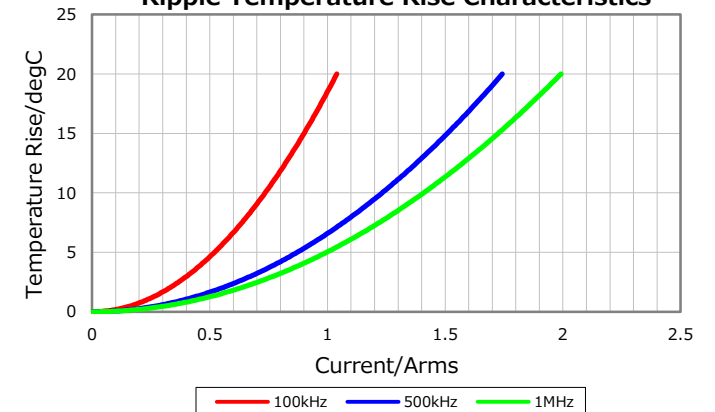

Characterization Sheet ( Multilayer Ceramic Chip Capacitors )



All specifications are subject to change without notice.

March 17, 2017