

# CGA6M1X7T2J154M200AE

TDK Item Description : CGA6M1X7T2J154MT\*\*\*S



Equivalent C3225X7T2J154M for Automotive

## Application & Main Feature

Automotive Grade ( Soft Termination )

## Series

CGA6(3225) [EIA CC1210]

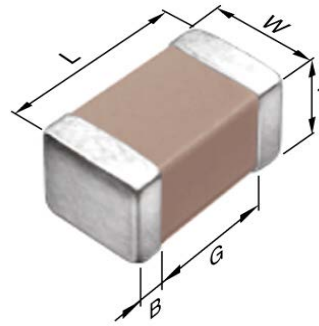

## Dimensions

L	3.20mm +0.5,-0.4mm
W	2.50mm +/-0.3mm
T	2.00mm +0.3,-0.2mm
B	0.20mm Min.
G	

## Temperature Characteristic

X7T (-55 to 125 degC +22,-33%)

## Rated Voltage

2J (630Vdc)

## Capacitance

150nF

## Capacitance Tolerance

M (+/-20%)

## Dissipation Factor

2.5% Max.

## Insulation Resistance

3.333Gohm Min

## AEC-Q200

Yes

**|Z|, ESR vs. Freq. Characteristics (Simulation Data)**

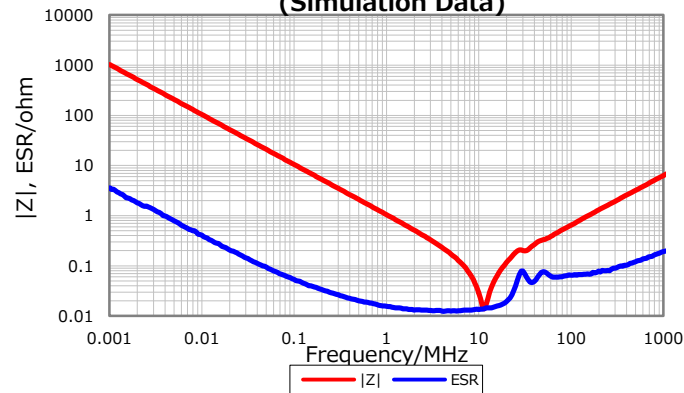

**Cap. vs. Freq. Characteristic**

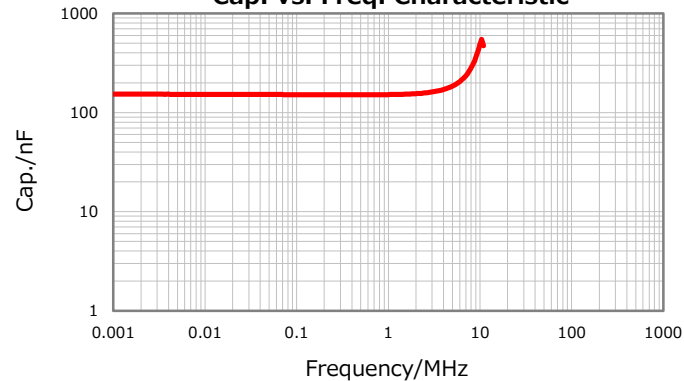

**DC Bias Characteristic**

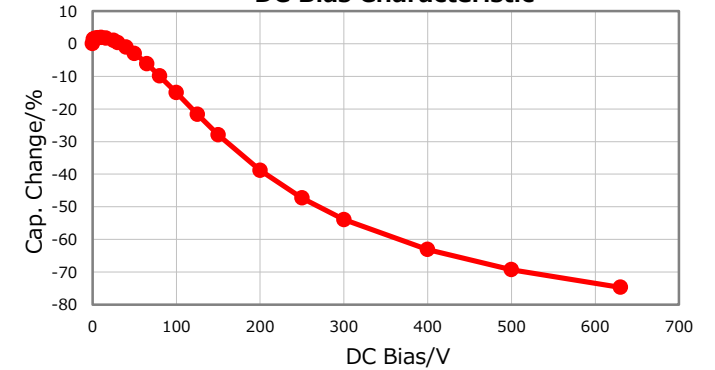

**Temperature Characteristics**

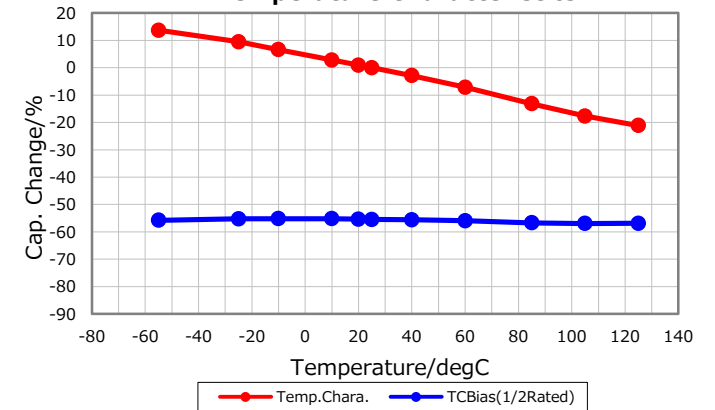

**Ripple Temperature Rise Characteristics**

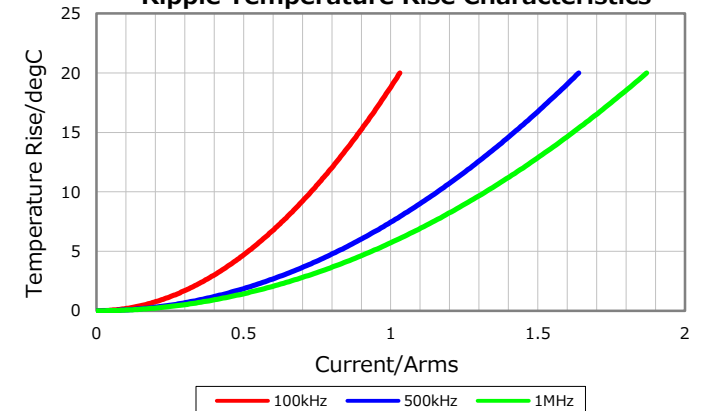

Characterization Sheet ( Multilayer Ceramic Chip Capacitors )



All specifications are subject to change without notice.

March 17, 2017