



Film Capacitors - Power Electronic Capacitors

PEC MKP DC

Series/Type: MKP DC High Frequency 2T & 4T (Resin top)
Ordering code: B25696H, B25697H
Date: April 2026
Version: 1

Rated capacitance: 47 μ F ... 1280 μ F
Rated DC Voltage: 900 V DC ... 2000 V DC



Construction

- Metallized polypropylene film
- Aluminum case and resin top
- Filling material: Non-PCB hard polyurethane resin (dry type)
- Diameter: 85 mm, 100 mm

Features

- Operating temperature range up to +85 °C
- Self-healing properties
- Ultra-low ESR and ESL
- High frequency performance, fully compatible with SiC semiconductors
- Low dissipation factor
- Naturally air cooled (or forced air cooling)
- IP00 Protection Degree (Indoor Mounting)
- Over-voltage capability
- RoHS compatible

Application

- DC link for renewable energy converters (solar, wind)
- DC link for traction applications (train, subway, tramway, light train inverters)
- DC link for industrial motor drive

Terminals

- Screw female (M6) terminals

Mounting

- Threaded bolt at the bottom of aluminum case (M12)

Packing

- 85 mm Diameter: 12 capacitors per box
- 100 mm Diameter: 4 capacitors per box
- Each carton box may contain carton plates to fill the empty space.

Technical data

Rated capacitance C_R	Up to 1280 μF
Standard capacitance tolerance	K: $\pm 10\%$
Rated DC voltage $V_{R,DC}$	900 ... 2000 V DC
Lifetime expectancy $t_{LD(\infty)}$ ¹⁾ (refer to section 4)	100 000 h at $T_{HS} +75\text{ }^\circ\text{C}$ and $V_{R,DC}$ up to 200 000 h (Considering deratings in voltage and/or temperature upon request)
Expected failure rate $\alpha_{FQ,(\infty)}$ ¹⁾	50 FIT at $V_{R,DC}$ and $+70\text{ }^\circ\text{C}$ (refer to section 5)
Maximum altitude	2000 m above sea level. Derating curves for altitudes higher than 2000 m available upon request
Smoke and fire compliant with EN 45545 (external materials: black resin, plastic ring, plastic deck)	For B25696H: HL1 (R22), HL2 (R23) HL2 (R22) and HL3 (R23) Hazard Level Classification are available upon request, but require investment in new tooling For B25697H: HL2 (R22), HL3 (R23)
Reference standards	IEC 61071-2017, GB/T 17702-2021, RoHS
Maximum ratings	
Maximum permissible voltage (V_{max})	$V_{R,DC} + 10\%$ (30 % of on-load daily duration) $V_{R,DC} + 15\%$ (up to 30 min daily) $V_{R,DC} + 20\%$ (up to 5 min daily) $V_{R,DC} + 30\%$ (up to 1 min daily)
Test data	
Voltage test between terminals V_{TT}	$1.5 V_{R,DC}$, 10 s
Voltage test between terminals and case V_{TC}	4000 V AC / 10 s
Climatic data	
Climatic category	40/85/56
Lower category T_{min}	$-40\text{ }^\circ\text{C}$
Upper category T_{max}	$+85\text{ }^\circ\text{C}$
Damp heat test	56 days 93 % RH @ $40\text{ }^\circ\text{C}$
Maximum hotspot temperature T_{HS} (see Terms)	$+85\text{ }^\circ\text{C}$
Mechanical data	
Max. torque terminal	5 Nm for female M6
Max. torque (M12) case stud	10 Nm

¹⁾ co: Continuous operation

1.1 Electrical characteristics
 $V_{R,DC} = 900 \text{ V DC} / V_{TT} = 1350 \text{ V DC}, 10 \text{ s} / V_{TC} = 4000 \text{ V AC}, 10 \text{ s}$

C_R μF	$I_{\max}^{2)}$ A, 60°C	$I_{\max}^{3)}$ A, 70°C	I_s kA	I_f kA	ESR ⁴⁾ mΩ	$L_{\text{self}}^{5)}$ nH	$R_{th}^{6)}$ K/W	ØD mm	$H_c^{7)}$ mm	H_t mm	Weight ⁸⁾ Kg	Fig. ⁹⁾	Ordering code
HF 2T design													
265	77	59	13.8	4.6	0.88	24	4.6	85	96	102	0.6	1	B25696H0267K901
400	77	59	13.8	4.6	1	25	4.0	85	126	132	0.8	1	B25696H0407K901
400	91	71	20.7	6.9	0.8	24	3.6	100	96	102	0.9	2	B25696H0407K911
525	77	59	13.7	4.6	1.11	26	3.6	85	154	160	0.9	1	B25696H0527K901
605	91	71	20.7	6.9	0.9	25	3.2	100	126	132	1.1	2	B25696H0607K901
625	75	58	13.7	4.6	1.23	27	3.4	85	176	182	1.1	1	B25696H0627K901
795	91	71	20.7	6.9	0.99	26	2.9	100	154	160	1.35	2	B25696H0797K901
850	74	57	13.7	4.6	1.45	29	3.0	85	226	232	1.4	1	B25696H0857K901
940	90	70	20.7	6.9	1.08	27	2.7	100	176	182	1.5	2	B25696H0947K901
1280	89	69	20.7	6.9	1.26	29	2.4	100	226	232	1.9	2	B25696H0128K901
HF 4T design													
410	114	88	19.3	6.4	0.46	8	3.8	100	96	102	0.95	3	B25697H0417K901*
605	114	88	19.4	6.5	0.53	9	3.3	100	126	132	1.2	3	B25697H0617K901*
735	113	87	19.4	6.5	0.59	10.5	3.1	100	146	152	1.4	3	B25697H0747K901
790	114	88	19.4	6.5	0.6	10.5	3.0	100	154	160	1.45	3	B25697H0797K901
930	111	85	19.4	6.5	0.67	11	2.8	100	176	182	1.55	3	B25697H0937K901
1130	106	82	19.5	6.5	0.75	11.5	2.7	100	206	212	1.8	3	B25697H0118K901
1260	102	79	19.4	6.5	0.8	12	2.8	100	226	232	2	3	B25697H0138K901

^{2/3)} I_{\max} is the typical value calculated for nominal value at 10 kHz, assuming:

- Ambient temperature at +70 °C for $T_{HS} \leq +85 \text{ °C}$, $\Delta T_{\max} \leq 15 \text{ K}$.
- Ambient temperature at +60 °C for $T_{HS} \leq +85 \text{ °C}$, $\Delta T_{\max} \leq 25 \text{ K}$.
- Natural convection (10 W/m²K) Thermal resistance ambient to HS, considering natural convection (10 W/(m²K)), terminals without temperature fixation and bottom screw connected to a piece with big thermal inertia.

For the details, please refer to section 3 (**current derating**).

^{4/5)} ESR is a typical value at 10 kHz. L_{self} is a typical value at 1 MHz.

⁶⁾ R_{th} ambient to HS, considering natural convection (10 W/m²K), terminals without temperature fixation and bottom screw connected to a piece with big thermal inertia.

^{7/8)} H_c is a typical value. Weight is a typical value.

⁹⁾ Refer to dimensional drawings on page 16 and 17.

Other configurations and capacitance tolerances are available upon request.

*** This ordering code is affected by "Dual Use" regulations according to Export Control law. Dual-use number is 3A201A1 or 3A201A2. Deliveries of such products are subject to prior approval by Export Control authorities based on customer declarations. The delivery to certain countries might be restricted.**

$V_{R, DC} = 1000 \text{ V DC} / V_{TT} = 1500 \text{ V DC}, 10 \text{ s} / V_{TC} = 4000 \text{ V AC}, 10 \text{ s}$

C_R μF	$I_{\text{max}}^{(2)}$ A, 60°C	$I_{\text{max}}^{(3)}$ A, 70°C	I_s kA	I kA	ESR ⁽⁴⁾ mΩ	$L_{\text{self}}^{(5)}$ nH	$R_{\text{th}}^{(6)}$ K/W	ØD mm	$H_c^{(7)}$ mm	H_t mm	Weight ⁽⁸⁾ Kg	Fig. ⁽⁹⁾	Ordering code
HF 2T design													
208	75	58	12.1	4.0	0.93	24	4.6	85	96	102	0.6	1	B25696H1207K001
313	75	58	12.0	4.0	1.06	25	4.0	85	126	132	0.8	1	B25696H1317K001
313	89	69	18.2	6.1	0.83	24	3.6	100	96	102	0.9	2	B25696H1317K011
410	74	57	12.0	4.0	1.18	26	3.6	85	154	160	0.9	1	B25696H1417K001
470	89	69	18.1	6.0	0.94	25	3.2	100	126	132	1.1	2	B25696H1477K001
490	73	56	12.0	4.0	1.3	27	3.4	85	176	182	1.1	1	B25696H1497K001
620	89	69	18.1	6.0	1.04	26	2.9	100	154	160	1.35	2	B25696H1627K001
665	72	55	12.0	4.0	1.54	29	3.0	85	226	232	1.4	1	B25696H1667K001
735	88	68	18.1	6.0	1.13	27	2.7	100	176	182	1.5	2	B25696H1737K001
1000	87	67	18.0	6.0	1.33	29	2.4	100	226	232	1.9	2	B25696H1108K001
HF 4T design													
325	111	86	17.5	5.8	0.49	8	3.8	100	96	102	0.95	3	B25697H1337K001*
485	111	86	17.5	5.8	0.57	9	3.3	100	126	132	1.2	3	B25697H1497K001*
590	110	85	17.5	5.8	0.62	10.5	3.1	100	146	152	1.4	3	B25697H1597K001
635	111	85	17.6	5.9	0.63	10.5	3.0	100	154	160	1.45	3	B25697H1647K001
750	107	83	17.5	5.8	0.71	11	2.8	100	176	182	1.55	3	B25697H1757K001
910	103	80	17.5	5.8	0.8	11.5	2.7	100	206	212	1.8	3	B25697H1917K001
1020	99	77	17.6	5.9	0.85	12	2.8	100	226	232	2	3	B25697H1108K001

^{2/3)} I_{max} is the typical value calculated for nominal value at 10 kHz, assuming:

- Ambient temperature at +70 °C for $T_{\text{HS}} \leq +85 \text{ °C}$, $\Delta T_{\text{max}} \leq 15 \text{ K}$.
- Ambient temperature at +60 °C for $T_{\text{HS}} \leq +85 \text{ °C}$, $\Delta T_{\text{max}} \leq 25 \text{ K}$.
- Natural convection (10 W/m²K) Thermal resistance ambient to HS, considering natural convection (10 W/(m²K)), terminals without temperature fixation and bottom screw connected to a piece with big thermal inertia.

 For the details, please refer to section 3 (**current derating**).

^{4/5)} ESR is a typical value at 10 kHz. L_{self} is a typical value at 1 MHz.

⁶⁾ R_{th} ambient to HS, considering natural convection (10 W/m²K), terminals without temperature fixation and bottom screw connected to a piece with big thermal inertia.

^{7/8)} H_c is a typical value. Weight is a typical value.

⁹⁾ Refer to dimensional drawings on page 16 and 17.

Other configurations and capacitance tolerances are available upon request.

*** This ordering code is affected by "Dual Use" regulations according to Export Control law. Dual-use number is 3A201A1 or 3A201A2. Deliveries of such products are subject to prior approval by Export Control authorities based on customer declarations. The delivery to certain countries might be restricted.**

$V_{R, DC} = 1100 \text{ V DC} / V_{TT} = 1650 \text{ V DC}, 10 \text{ s} / V_{TC} = 4000 \text{ V AC}, 10 \text{ s}$

C_R μF	$I_{\max}^{2)}$ A, 60°C	$I_{\max}^{3)}$ A, 70°C	I_s kA	I kA	ESR ⁴⁾ mΩ	$L_{\text{self}}^{5)}$ nH	$R_{th}^{6)}$ K/W	ØD mm	$H_c^{7)}$ mm	H_t mm	Weight ⁸⁾ Kg	Fig. ⁹⁾	Ordering code
HF 2T design													
170	73	56	14.5	4.8	0.98	24	4.6	85	96	102	0.6	1	B25696H1177K101
255	73	56	14.4	4.8	1.12	25	4.0	85	126	132	0.8	1	B25696H1257K101
256	88	68	21.9	7.3	0.86	24	3.6	100	96	102	0.9	2	B25696H1257K111
335	72	56	14.3	4.8	1.24	26	3.6	85	154	160	0.9	1	B25696H1337K101
385	88	68	21.7	7.2	0.97	25	3.2	100	126	132	1.1	2	B25696H1387K101
400	71	55	14.4	4.8	1.37	27	3.4	85	176	182	1.1	1	B25696H1407K101
508	88	68	21.8	7.3	1.08	26	2.9	100	154	160	1.35	2	B25696H1507K101
542	70	54	14.3	4.8	1.64	29	3.0	85	226	232	1.4	1	B25696H1547K101
603	87	67	21.7	7.2	1.18	27	2.7	100	176	182	1.5	2	B25696H1607K101
820	85	66	21.7	7.2	1.39	29	2.4	100	226	232	1.9	2	B25696H1827K101
HF 4T design													
270	108	83	21.3	7.1	0.52	8	3.8	100	96	102	0.95	3	B25697H1277K101*
400	108	83	21.2	7.1	0.6	9	3.3	100	126	132	1.2	3	B25697H1407K101*
490	107	82	21.3	7.1	0.66	10.5	3.1	100	146	152	1.4	3	B25697H1497K101
525	107	83	21.3	7.1	0.67	10.5	3.0	100	154	160	1.45	3	B25697H1537K101
620	104	80	21.2	7.1	0.75	11	2.8	100	176	182	1.55	3	B25697H1627K101
755	100	77	21.3	7.1	0.84	11.5	2.7	100	206	212	1.8	3	B25697H1767K101
840	96	74	21.2	7.1	0.91	12	2.8	100	226	232	2	3	B25697H1847K101

^{2/3)} I_{\max} is the typical value calculated for nominal value at 10 kHz, assuming:

- Ambient temperature at +70 °C for $T_{HS} \leq +85 \text{ °C}$, $\Delta T_{\max} \leq 15 \text{ K}$.
- Ambient temperature at +60 °C for $T_{HS} \leq +85 \text{ °C}$, $\Delta T_{\max} \leq 25 \text{ K}$.
- Natural convection (10 W/m²K) Thermal resistance ambient to HS, considering natural convection (10 W/(m²K)), terminals without temperature fixation and bottom screw connected to a piece with big thermal inertia.

 For the details, please refer to section 3 (**current derating**).

^{4/5)} ESR is a typical value at 10 kHz. L_{self} is a typical value at 1 MHz.

⁶⁾ R_{th} ambient to HS, considering natural convection (10 W/m²K), terminals without temperature fixation and bottom screw connected to a piece with big thermal inertia.

^{7/8)} H_c is a typical value. Weight is a typical value.

⁹⁾ Refer to dimensional drawings on page 16 and 17.

Other configurations and capacitance tolerances are available upon request.

*** This ordering code is affected by "Dual Use" regulations according to Export Control law. Dual-use number is 3A201A1 or 3A201A2. Deliveries of such products are subject to prior approval by Export Control authorities based on customer declarations. The delivery to certain countries might be restricted.**

$V_{R, DC} = 1200 \text{ V DC} / V_{TT} = 1800 \text{ V DC}, 10 \text{ s} / V_{TC} = 4000 \text{ V AC}, 10 \text{ s}$

C_R μF	$I_{\max}^{2)}$ A, 60°C	$I_{\max}^{3)}$ A, 70°C	I_s kA	I kA	ESR ⁴⁾ mΩ	$L_{\text{self}}^{5)}$ nH	$R_{th}^{6)}$ K/W	ØD mm	$H_c^{7)}$ mm	H_t mm	Weight ⁸⁾ Kg	Fig. ⁹⁾	Ordering code
HF 2T design													
128	70	54	12.7	4.2	1.06	24	4.6	85	96	102	0.6	1	B25696H1127K201
193	70	54	12.6	4.2	1.21	25	4.0	85	126	132	0.8	1	B25696H1197K201
194	85	66	19.2	6.4	0.91	24	3.6	100	96	102	0.9	2	B25696H1197K211
254	70	54	12.6	4.2	1.34	27	3.6	85	154	160	0.9	1	B25696H1257K201
292	85	66	19.1	6.4	1.03	25	3.2	100	126	132	1.1	2	B25696H1297K201
302	68	53	12.6	4.2	1.49	27	3.4	85	176	182	1.1	1	B25696H1307K201
384	85	66	19.1	6.4	1.14	26	2.9	100	154	160	1.35	2	B25696H1387K201
410	67	52	12.6	4.2	1.77	30	3.0	85	226	232	1.4	1	B25696H1417K201
455	84	65	19.0	6.3	1.26	27	2.7	100	176	182	1.5	2	B25696H1457K201
620	83	64	19.0	6.3	1.48	29	2.4	100	226	232	1.9	2	B25696H1627K201
HF 4T design													
220	104	80	19.2	6.4	0.56	8	3.8	100	96	102	0.95	3	B25697H1227K201*
330	104	80	19.3	6.4	0.64	9	3.3	100	126	132	1.2	3	B25697H1337K201*
400	103	80	19.2	6.4	0.71	10.5	3.1	100	146	152	1.4	3	B25697H1407K201
430	104	80	19.3	6.4	0.71	10.5	3.0	100	154	160	1.45	3	B25697H1437K201
510	101	78	19.3	6.4	0.8	11	2.8	100	176	182	1.55	3	B25697H1517K201
615	97	75	19.2	6.4	0.91	11.5	2.7	100	206	212	1.8	3	B25697H1627K201
690	93	72	19.3	6.4	0.97	12	2.8	100	226	232	2	3	B25697H1697K201

^{2/3)} I_{\max} is the typical value calculated for nominal value at 10 kHz, assuming:

- Ambient temperature at +70 °C for $T_{HS} \leq +85 \text{ °C}$, $\Delta T_{\max} \leq 15 \text{ K}$.
- Ambient temperature at +60 °C for $T_{HS} \leq +85 \text{ °C}$, $\Delta T_{\max} \leq 25 \text{ K}$.
- Natural convection (10 W/m²K) Thermal resistance ambient to HS, considering natural convection (10 W/(m²K)), terminals without temperature fixation and bottom screw connected to a piece with big thermal inertia.

 For the details, please refer to section 3 (**current derating**).

^{4/5)} ESR is a typical value at 10 kHz. L_{self} is a typical value at 1 MHz.

⁶⁾ R_{th} ambient to HS, considering natural convection (10 W/m²K), terminals without temperature fixation and bottom screw connected to a piece with big thermal inertia.

^{7/8)} H_c is a typical value. Weight is a typical value.

⁹⁾ Refer to dimensional drawings on page 16 and 17.

Other configurations and capacitance tolerances are available upon request.

*** This ordering code is affected by "Dual Use" regulations according to Export Control law. Dual-use number is 3A201A1 or 3A201A2. Deliveries of such products are subject to prior approval by Export Control authorities based on customer declarations. The delivery to certain countries might be restricted.**

$V_{R,DC} = 1300 \text{ V DC} / V_{TT} = 1950 \text{ V DC}, 10 \text{ s} / V_{TC} = 4000 \text{ V AC}, 10 \text{ s}$

C_R μF	$I_{\max}^{(2)}$ A, 60°C	$I_{\max}^{(3)}$ A, 70°C	I_s kA	I kA	ESR ⁽⁴⁾ mΩ	$L_{\text{self}}^{(5)}$ nH	$R_{th}^{(6)}$ K/W	ØD mm	$H_c^{(7)}$ mm	H_t mm	Weight ⁽⁸⁾ Kg	Fig. ⁽⁹⁾	Ordering code
HF 2T design													
106	69	54	12.1	4.0	1.08	24	4.6	85	96	102	0.6	1	B25696H1107K301
160	84	65	18.3	6.1	0.93	24	3.6	100	96	102	0.9	2	B25696H1167K311
166	69	54	12.1	4.0	1.23	25	4.0	85	126	132	0.8	1	B25696H1167K301
222	69	53	12.1	4.0	1.36	26	3.6	85	154	160	0.9	1	B25696H1227K301
250	84	65	18.2	6.1	1.05	25	3.2	100	126	132	1.1	2	B25696H1257K301
265	68	52	12.0	4.0	1.52	27	3.4	85	176	182	1.1	1	B25696H1267K301
334	84	65	18.2	6.1	1.16	26	2.9	100	154	160	1.35	2	B25696H1337K301
365	66	51	12.0	4.0	1.82	29	3.0	85	226	232	1.4	1	B25696H1367K301
400	83	64	18.1	6.0	1.27	27	2.7	100	176	182	1.5	2	B25696H1407K301
550	82	63	18.1	6.0	1.5	29	2.4	100	226	232	1.9	2	B25696H1557K301
HF 4T design													
185	101	78	17.6	5.9	0.59	8	3.8	100	96	102	0.95	3	B25697H1197K301*
275	101	78	17.5	5.8	0.68	9	3.3	100	126	132	1.2	3	B25697H1287K301*
335	100	77	17.5	5.8	0.75	10.5	3.1	100	146	152	1.4	3	B25697H1347K301
360	101	78	17.6	5.9	0.76	10.5	3.0	100	154	160	1.45	3	B25697H1367K301
430	98	76	17.7	5.9	0.85	11	2.8	100	176	182	1.55	3	B25697H1437K301
520	94	72	17.7	5.9	0.96	11.5	2.7	100	206	212	1.8	3	B25697H1527K301
580	90	70	17.6	5.9	1.03	12	2.8	100	226	232	2	3	B25697H1587K301

^{2/3)} I_{\max} is the typical value calculated for nominal value at 10 kHz, assuming:

- Ambient temperature at +70 °C for $T_{HS} \leq +85 \text{ °C}$, $\Delta T_{\max} \leq 15 \text{ K}$.
- Ambient temperature at +60 °C for $T_{HS} \leq +85 \text{ °C}$, $\Delta T_{\max} \leq 25 \text{ K}$.
- Natural convection (10 W/m²K) Thermal resistance ambient to HS, considering natural convection (10 W/(m²K)), terminals without temperature fixation and bottom screw connected to a piece with big thermal inertia.

 For the details, please refer to section 3 (**current derating**).

^{4/5)} ESR is a typical value at 10 kHz. L_{self} is a typical value at 1 MHz.

⁶⁾ R_{th} ambient to HS, considering natural convection (10 W/m²K), terminals without temperature fixation and bottom screw connected to a piece with big thermal inertia.

^{7/8)} H_c is a typical value. Weight is a typical value.

⁹⁾ Refer to dimensional drawings on page 16 and 17.

Other configurations and capacitance tolerances are available upon request.

*** This ordering code is affected by "Dual Use" regulations according to Export Control law. Dual-use number is 3A201A1 or 3A201A2. Deliveries of such products are subject to prior approval by Export Control authorities based on customer declarations. The delivery to certain countries might be restricted.**

$V_{R, DC} = 1500 \text{ V DC} / V_{TT} = 2250 \text{ V DC}, 10 \text{ s} / V_{TC} = 4000 \text{ V AC}, 10 \text{ s}$

C_R μF	$I_{\text{max}}^{(2)}$ A, 60°C	$I_{\text{max}}^{(3)}$ A, 70°C	I_s kA	I kA	ESR ⁽⁴⁾ mΩ	$L_{\text{self}}^{(5)}$ nH	$R_{\text{th}}^{(6)}$ K/W	ØD mm	$H_c^{(7)}$ mm	H_t mm	Weight ⁽⁸⁾ Kg	Fig. ⁽⁹⁾	Ordering code
HF 2T design													
92	68	52	11.4	3.8	1.13	24	4.6	85	96	102	0.6	1	B25696H1926K501*
137	83	64	17.0	5.7	0.97	24	3.6	100	96	102	0.9	2	B25696H1137K501*
142	68	52	11.2	3.7	1.29	25	4.0	85	126	132	0.8	1	B25696H1147K501*
190	68	52	11.2	3.7	1.43	26	3.6	85	154	160	0.9	1	B25696H1197K501*
214	83	64	16.8	5.6	1.09	25	3.2	100	126	132	1.1	2	B25696H1217K501*
228	66	51	11.2	3.7	1.58	27	3.4	85	176	182	1.1	1	B25696H1227K501*
286	83	64	16.8	5.6	1.2	26	2.9	100	154	160	1.35	2	B25696H1287K501*
313	64	50	11.1	3.7	1.91	30	3.0	85	226	232	1.4	1	B25696H1317K501*
343	82	63	16.8	5.6	1.32	27	2.7	100	176	182	1.5	2	B25696H1347K501*
472	80	62	16.8	5.6	1.56	29	2.4	100	226	232	1.9	2	B25696H1477K501*
HF 4T design													
154	99	76	16.3	5.4	0.62	8	3.8	100	96	102	0.95	3	B25697H1157K501*
230	98	76	16.2	5.4	0.72	9	3.3	100	126	132	1.2	3	B25697H1237K501*
285	98	76	16.4	5.5	0.78	10.5	3.1	100	146	152	1.4	3	B25697H1297K501*
305	98	76	16.4	5.5	0.8	10.5	3.0	100	154	160	1.45	3	B25697H1317K501*
360	95	73	16.3	5.4	0.9	11	2.8	100	176	182	1.55	3	B25697H1367K501*
440	91	71	16.3	5.4	1.01	11.5	2.7	100	206	212	1.8	3	B25697H1447K501*
494	88	68	16.4	5.5	1.08	12	2.8	100	226	232	2	3	B25697H1497K501*

^{2/3)} I_{max} is the typical value calculated for nominal value at 10 kHz, assuming:

- Ambient temperature at +70 °C for $T_{\text{HS}} \leq +85 \text{ °C}$, $\Delta T_{\text{max}} \leq 15 \text{ K}$.
- Ambient temperature at +60 °C for $T_{\text{HS}} \leq +85 \text{ °C}$, $\Delta T_{\text{max}} \leq 25 \text{ K}$.
- Natural convection (10 W/m²K) Thermal resistance ambient to HS, considering natural convection (10 W/(m²K)), terminals without temperature fixation and bottom screw connected to a piece with big thermal inertia.

 For the details, please refer to section 3 (**current derating**).

^{4/5)} ESR is a typical value at 10 kHz. L_{self} is a typical value at 1 MHz.

⁶⁾ R_{th} ambient to HS, considering natural convection (10 W/m²K), terminals without temperature fixation and bottom screw connected to a piece with big thermal inertia.

^{7/8)} H_c is a typical value. Weight is a typical value.

⁹⁾ Refer to dimensional drawings on page 16 and 17.

Other configurations and capacitance tolerances are available upon request.

*** This ordering code is affected by "Dual Use" regulations according to Export Control law. Dual-use number is 3A201A1 or 3A201A2. Deliveries of such products are subject to prior approval by Export Control authorities based on customer declarations. The delivery to certain countries might be restricted.**

$V_{R, DC} = 1600 \text{ V DC} / V_{TT} = 2400 \text{ V DC}, 10 \text{ s} / V_{TC} = 4000 \text{ V AC}, 10 \text{ s}$

C_R μF	$I_{\max}^{(2)}$ A, 60°C	$I_{\max}^{(3)}$ A, 70°C	I_s kA	I kA	ESR ⁽⁴⁾ mΩ	$L_{\text{self}}^{(5)}$ nH	$R_{th}^{(6)}$ K/W	ØD mm	$H_c^{(7)}$ mm	H_t mm	Weight ⁽⁸⁾ Kg	Fig. ⁽⁹⁾	Ordering code
HF 2T design													
80	66	51	10.7	3.6	1.18	24	4.6	85	96	102	0.6	1	B25696H1806K601*
120	82	63	16.0	5.3	1	24	3.6	100	96	102	0.9	2	B25696H1127K611*
124	66	51	10.6	3.5	1.35	25	4.0	85	126	132	0.8	1	B25696H1127K601*
166	66	51	10.6	3.5	1.49	26	3.6	85	154	160	0.9	1	B25696H1167K601*
188	82	63	16.0	5.3	1.12	25	3.2	100	126	132	1.1	2	B25696H1187K601*
200	65	50	10.7	3.6	1.65	27	3.4	85	176	182	1.1	1	B25696H1207K601*
251	82	63	15.9	5.3	1.24	26	2.9	100	154	160	1.35	2	B25696H1257K601*
275	63	49	10.7	3.6	1.98	30	3.0	85	226	232	1.4	1	B25696H1277K601*
301	81	62	15.9	5.3	1.36	27	2.7	100	176	182	1.5	2	B25696H1307K601*
414	79	61	15.9	5.3	1.61	29	2.4	100	226	232	1.9	2	B25696H1417K601*
HF 4T design													
129	96	74	14.9	5.0	0.66	8	3.8	100	96	102	0.95	3	B25697H1137K601*
195	96	74	15.0	5.0	0.76	9	3.3	100	126	132	1.2	3	B25697H1207K601*
239	95	73	15.0	5.0	0.83	10.5	3.1	100	146	152	1.4	3	B25697H1247K601*
255	95	74	14.9	5.0	0.85	10.5	3.0	100	154	160	1.45	3	B25697H1267K601*
305	93	71	15.0	5.0	0.95	11	2.8	100	176	182	1.55	3	B25697H1317K601*
370	89	68	15.0	5.0	1.08	11.5	2.7	100	206	212	1.8	3	B25697H1377K601*
414	85	66	15.0	5.0	1.16	12	2.8	100	226	232	2	3	B25697H1417K601*

^{2/3)} I_{\max} is the typical value calculated for nominal value at 10 kHz, assuming:

- Ambient temperature at +70 °C for $T_{HS} \leq +85 \text{ °C}$, $\Delta T_{\max} \leq 15 \text{ K}$.
- Ambient temperature at +60 °C for $T_{HS} \leq +85 \text{ °C}$, $\Delta T_{\max} \leq 25 \text{ K}$.
- Natural convection (10 W/m²K) Thermal resistance ambient to HS, considering natural convection (10 W/(m²K)), terminals without temperature fixation and bottom screw connected to a piece with big thermal inertia.

 For the details, please refer to section 3 (**current derating**).

^{4/5)} ESR is a typical value at 10 kHz. L_{self} is a typical value at 1 MHz.

⁶⁾ R_{th} ambient to HS, considering natural convection (10 W/m²K), terminals without temperature fixation and bottom screw connected to a piece with big thermal inertia.

^{7/8)} H_c is a typical value. Weight is a typical value.

⁹⁾ Refer to dimensional drawings on page 16 and 17.

Other configurations and capacitance tolerances are available upon request.

*** This ordering code is affected by "Dual Use" regulations according to Export Control law. Dual-use number is 3A201A1 or 3A201A2. Deliveries of such products are subject to prior approval by Export Control authorities based on customer declarations. The delivery to certain countries might be restricted.**

$V_{R, DC} = 1700 \text{ V DC} / V_{TT} = 2550 \text{ V DC}, 10 \text{ s} / V_{TC} = 4000 \text{ V AC}, 10 \text{ s}$

C_R μF	$I_{\max}^{(2)}$ A, 60°C	$I_{\max}^{(3)}$ A, 70°C	I_s kA	I kA	ESR ⁽⁴⁾ mΩ	$L_{\text{self}}^{(5)}$ nH	$R_{th}^{(6)}$ K/W	ØD mm	$H_c^{(7)}$ mm	H_t mm	Weight ⁽⁸⁾ Kg	Fig. ⁽⁹⁾	Ordering code
HF 2T design													
67	64	50	9.7	3.2	1.25	24	4.6	85	96	102	0.6	1	B25696H1676K701*
101	80	62	14.6	4.9	1.04	24	3.6	100	96	102	0.9	2	B25696H1107K711*
105	65	50	9.7	3.2	1.42	25	4.0	85	126	132	0.8	1	B25696H1107K701*
140	64	50	9.6	3.2	1.57	26	3.6	85	154	160	0.9	1	B25696H1147K701*
159	80	62	14.6	4.9	1.17	25	3.2	100	126	132	1.1	2	B25696H1157K701*
168	63	49	9.6	3.2	1.75	28	3.4	85	176	182	1.1	1	B25696H1167K701*
212	80	62	14.6	4.9	1.29	26	2.9	100	154	160	1.35	2	B25696H1217K701*
232	61	47	9.7	3.2	2.1	30	3.0	85	226	232	1.4	1	B25696H1237K701*
254	79	61	14.6	4.9	1.43	27	2.7	100	176	182	1.5	2	B25696H1257K701*
350	77	60	14.6	4.9	1.69	29	2.4	100	226	232	1.9	2	B25696H1357K701*
HF 4T design													
109	93	72	14.0	4.7	0.7	8	3.8	100	96	102	0.95	3	B25697H1117K701*
165	93	72	13.9	4.6	0.8	9	3.3	100	126	132	1.2	3	B25697H1177K701*
204	93	71	14.0	4.7	0.88	10.5	3.1	100	146	152	1.4	3	B25697H1207K701*
219	93	72	14.0	4.7	0.89	10.5	3.0	100	154	160	1.45	3	B25697H1227K701*
260	90	70	13.9	4.6	1	11	2.8	100	176	182	1.55	3	B25697H1267K701*
315	86	67	13.9	4.6	1.14	11.5	2.7	100	206	212	1.8	3	B25697H1327K701*
355	83	64	14.0	4.7	1.22	12	2.8	100	226	232	2	3	B25697H1367K701*

^{2/3)} I_{\max} is the typical value calculated for nominal value at 10 kHz, assuming:

- Ambient temperature at +70 °C for $T_{HS} \leq +85 \text{ °C}$, $\Delta T_{\max} \leq 15 \text{ K}$.
- Ambient temperature at +60 °C for $T_{HS} \leq +85 \text{ °C}$, $\Delta T_{\max} \leq 25 \text{ K}$.
- Natural convection (10 W/m²K) Thermal resistance ambient to HS, considering natural convection (10 W/(m²K)), terminals without temperature fixation and bottom screw connected to a piece with big thermal inertia.

 For the details, please refer to section 3 (**current derating**).

^{4/5)} ESR is a typical value at 10 kHz. L_{self} is a typical value at 1 MHz.

⁶⁾ R_{th} ambient to HS, considering natural convection (10 W/m²K), terminals without temperature fixation and bottom screw connected to a piece with big thermal inertia.

^{7/8)} H_c is a typical value. Weight is a typical value.

⁹⁾ Refer to dimensional drawings on page 16 and 17.

Other configurations and capacitance tolerances are available upon request.

*** This ordering code is affected by "Dual Use" regulations according to Export Control law. Dual-use number is 3A201A1 or 3A201A2. Deliveries of such products are subject to prior approval by Export Control authorities based on customer declarations. The delivery to certain countries might be restricted.**

$V_{R, DC} = 1800 \text{ V DC} / V_{TT} = 2700 \text{ V DC}, 10 \text{ s} / V_{TC} = 4000 \text{ V AC}, 10 \text{ s}$

C_R μF	$I_{\text{max}}^{(2)}$ A, 60°C	$I_{\text{max}}^{(3)}$ A, 70°C	I_s kA	I kA	ESR ⁽⁴⁾ mΩ	$L_{\text{self}}^{(5)}$ nH	$R_{\text{th}}^{(6)}$ K/W	ØD mm	$H_c^{(7)}$ mm	H_t mm	Weight ⁽⁸⁾ Kg	Fig. ⁽⁹⁾	Ordering code
HF 2T design													
60	63	49	9.2	3.1	1.3	25	4.6	85	96	102	0.6	1	B25696H1606K801*
91	79	61	13.9	4.6	1.07	23	3.6	100	96	102	0.9	2	B25696H1916K801*
94	63	49	9.1	3.0	1.47	25	4.0	85	126	132	0.8	1	B25696H1946K801*
126	63	49	9.1	3.0	1.62	26	3.6	85	154	160	0.9	1	B25696H1127K801*
143	79	61	13.9	4.6	1.2	25	3.2	100	126	132	1.1	2	B25696H1147K801*
151	62	48	9.1	3.0	1.81	28	3.4	85	176	182	1.1	1	B25696H1157K801*
190	79	61	13.8	4.6	1.33	26	2.9	100	154	160	1.35	2	B25696H1197K801*
208	60	47	9.1	3.0	2.18	30	3.0	85	226	232	1.4	1	B25696H1207K801*
228	78	60	13.8	4.6	1.47	27	2.7	100	176	182	1.5	2	B25696H1227K801*
314	76	59	13.8	4.6	1.74	29	2.4	100	226	232	1.9	2	B25696H1317K801*
HF 4T design													
98	91	71	13.3	4.4	0.72	8	3.8	100	96	102	0.95	3	B25697H1986K801*
149	91	71	13.3	4.4	0.83	9	3.3	100	126	132	1.2	3	B25697H1157K801*
183	91	70	13.2	4.4	0.91	10.5	3.1	100	146	152	1.4	3	B25697H1187K801*
197	91	70	13.3	4.4	0.93	10.5	3.0	100	154	160	1.45	3	B25697H1207K801*
235	88	68	13.3	4.4	1.04	11	2.8	100	176	182	1.55	3	B25697H1247K801*
285	85	65	13.2	4.4	1.18	11.5	2.7	100	206	212	1.8	3	B25697H1297K801*
320	81	63	13.3	4.4	1.27	12	2.8	100	226	232	2	3	B25697H1327K801*

^{2/3)} I_{max} is the typical value calculated for nominal value at 10 kHz, assuming:

- Ambient temperature at +70 °C for $T_{\text{HS}} \leq +85 \text{ °C}$, $\Delta T_{\text{max}} \leq 15 \text{ K}$.
- Ambient temperature at +60 °C for $T_{\text{HS}} \leq +85 \text{ °C}$, $\Delta T_{\text{max}} \leq 25 \text{ K}$.
- Natural convection (10 W/m²K) Thermal resistance ambient to HS, considering natural convection (10 W/(m²K)), terminals without temperature fixation and bottom screw connected to a piece with big thermal inertia.

 For the details, please refer to section 3 (**current derating**).

^{4/5)} ESR is a typical value at 10 kHz. L_{self} is a typical value at 1 MHz.

⁶⁾ R_{th} ambient to HS, considering natural convection (10 W/m²K), terminals without temperature fixation and bottom screw connected to a piece with big thermal inertia.

^{7/8)} H_c is a typical value. Weight is a typical value.

⁹⁾ Refer to dimensional drawings on page 16 and 17.

Other configurations and capacitance tolerances are available upon request.

*** This ordering code is affected by "Dual Use" regulations according to Export Control law. Dual-use number is 3A201A1 or 3A201A2. Deliveries of such products are subject to prior approval by Export Control authorities based on customer declarations. The delivery to certain countries might be restricted.**

$V_{R, DC} = 2000 \text{ V DC} / V_{TT} = 3000 \text{ V DC}, 10 \text{ s} / V_{TC} = 4000 \text{ V AC}, 10 \text{ s}$

C_R μF	$I_{\max}^{2)}$ A, 60°C	$I_{\max}^{3)}$ A, 70°C	\hat{I}_s kA	\hat{I} kA	ESR ⁴⁾ mΩ	$L_{\text{self}}^{5)}$ nH	$R_{th}^{6)}$ K/W	ØD mm	$H_c^{7)}$ mm	H_t mm	Weight ⁸⁾ Kg	Fig. ⁹⁾	Ordering code
HF 2T design													
47	61	47	8.1	2.7	1.41	25	4.6	85	96	102	0.6	1	B25696H2476K001*
71	76	59	12.2	4.1	1.15	23	3.6	100	96	102	0.9	2	B25696H2716K001*
74	61	47	8.1	2.7	1.59	25	4.0	85	126	132	0.8	1	B25696H2746K001*
100	61	47	8.1	2.7	1.75	26	3.6	85	154	160	0.9	1	B25696H2107K001*
112	76	59	12.2	4.1	1.28	25	3.2	100	126	132	1.1	2	B25696H2117K011*
119	59	46	8.1	2.7	1.96	27	3.4	85	176	182	1.1	1	B25696H2117K001*
150	76	59	12.2	4.1	1.42	26	2.9	100	154	160	1.35	2	B25696H2157K001*
163	58	45	8.0	2.7	2.37	30	3.0	85	226	232	1.4	1	B25696H2167K001*
180	75	58	12.2	4.1	1.57	27	2.7	100	176	182	1.5	2	B25696H2187K001*
247	73	57	12.2	4.1	1.86	29	2.4	100	226	232	1.9	2	B25696H2247K001*
HF 4T design													
77	87	67	11.7	3.9	0.8	8	3.8	100	96	102	0.95	3	B25697H2776K001*
118	87	67	11.8	3.9	0.91	9	3.3	100	126	132	1.2	3	B25697H2127K001*
145	87	67	11.8	3.9	1	10.5	3.1	100	146	152	1.4	3	B25697H2157K001*
156	87	67	11.8	3.9	1.01	10.5	3.0	100	154	160	1.45	3	B25697H2167K001*
185	84	65	11.7	3.9	1.14	11	2.8	100	176	182	1.55	3	B25697H2197K001*
227	81	63	11.8	3.9	1.28	11.5	2.7	100	206	212	1.8	3	B25697H2237K001*
254	78	60	11.8	3.9	1.39	12	2.8	100	226	232	2	3	B25697H2257K001*

^{2/3)} I_{\max} is the typical value calculated for nominal value at 10 kHz, assuming:

- Ambient temperature at +70 °C for $T_{HS} \leq +85 \text{ °C}$, $\Delta T_{\max} \leq 15 \text{ K}$.
- Ambient temperature at +60 °C for $T_{HS} \leq +85 \text{ °C}$, $\Delta T_{\max} \leq 25 \text{ K}$.
- Natural convection (10 W/m²K) Thermal resistance ambient to HS, considering natural convection (10 W/(m²K)), terminals without temperature fixation and bottom screw connected to a piece with big thermal inertia.

For the details, please refer to section 3 (**current derating**).

^{4/5)} ESR is a typical value at 10 kHz. L_{self} is a typical value at 1 MHz.

⁶⁾ R_{th} ambient to HS, considering natural convection (10 W/m²K), terminals without temperature fixation and bottom screw connected to a piece with big thermal inertia.

^{7/8)} H_c is a typical value. Weight is a typical value.

⁹⁾ Refer to dimensional drawings on page 16 and 17.

Other configurations and capacitance tolerances are available upon request.

*** This ordering code is affected by "Dual Use" regulations according to Export Control law. Dual-use number is 3A201A1 or 3A201A2. Deliveries of such products are subject to prior approval by Export Control authorities based on customer declarations. The delivery to certain countries might be restricted.**

1.2 Performance comparison

Compared to the standard series of the same size and rating, the HF 4T series has more than twice the self-resonance frequency and at least 70% lower self-inductance (as low as 8~12nH), thanks to its excellent internal wiring design. High-frequency performance is critical for SiC semiconductors.

Compared type: $V_{R,DC} = 900VDC$, dimensions $\varnothing 100 \times 226 \times 232$

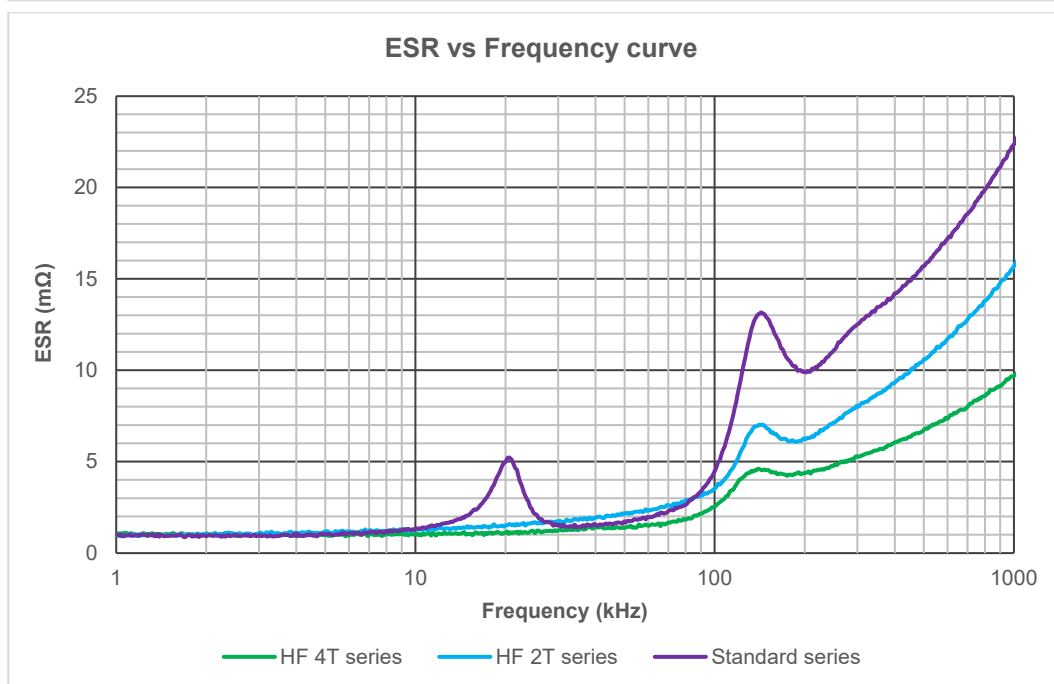
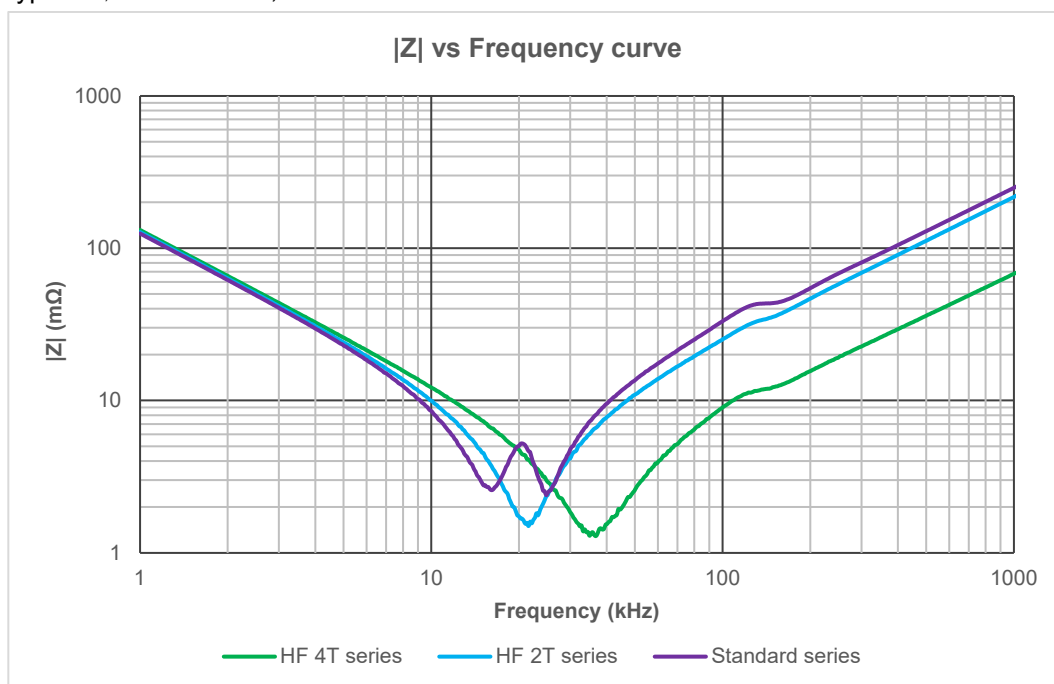

1.3 Structure of ordering code

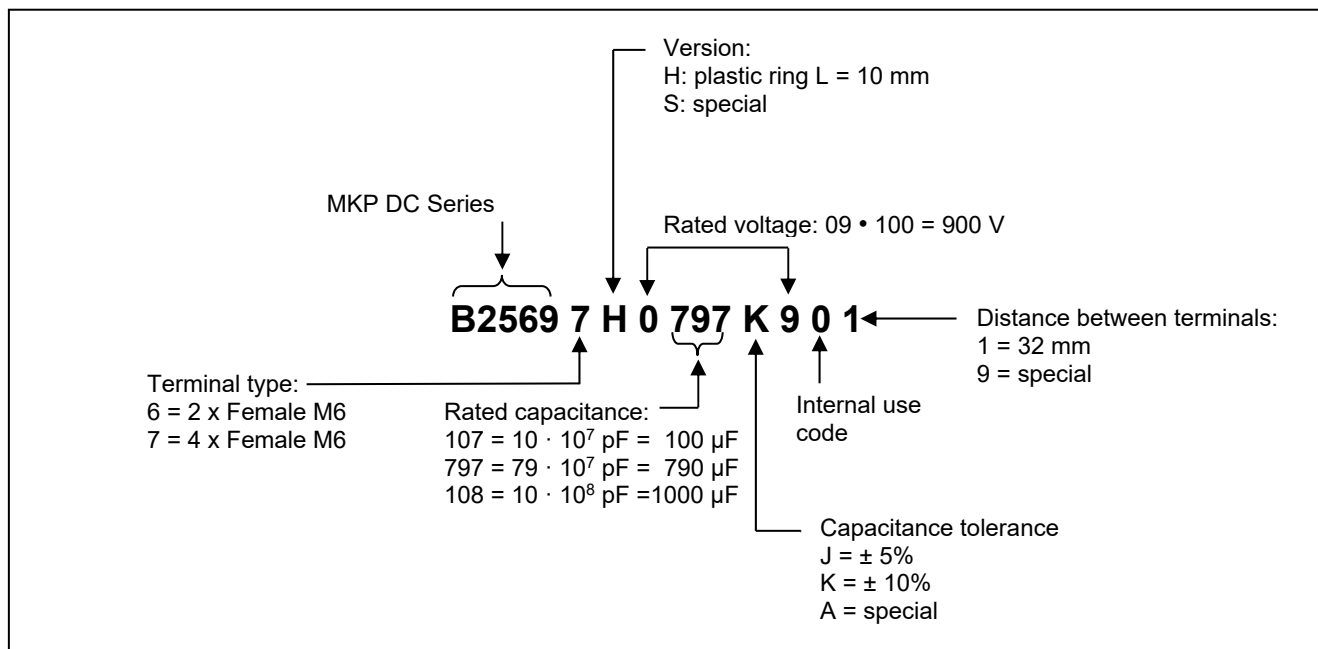

Display of ordering codes for TDK Electronics products

The ordering code for one and the same product can be represented differently in data sheets, data books, other publications, on the company website, or in order-related documents such as shipping notes, order confirmations and product labels. **The varying representations of the ordering codes are due to different processes employed and do not affect the specifications of the respective products.** Detailed information can be found on the Internet under www.tdk-electronics.tdk.com/orderingcodes.

1.4 Label Information

TDK

B25697H0797K901

790 μ F	=	$\pm 10\%$
V_{RDC}	=	900V
V_{TC}	=	4kV
-40...+85°C		IEC 61071
SH-No PCB		Dry Type
Max. torque of terminals: 5Nm		
Discharge before handling		
Made by TDK		46 Z 2025

Barcode: 123456789001

Date code explanation (46 Z 2025)

CW Z YYYY: production week (e.g.: CW46)
CW Z YYYY: produced in Zhuhai (China)
CW Z YYYY: production year (e.g.: 2025)

Bar code explanation

Bar code consists of batch number and serial number.
 Batch number: 9 digits (e.g.: 123456789)
 Serial number: 3 digits (e.g.: 001)

1.5 Dimensional drawings
Figure 1: - B25696H – ØD = 85 mm

- Female terminals (M6)
- Between terminals 32 ± 0.5 mm

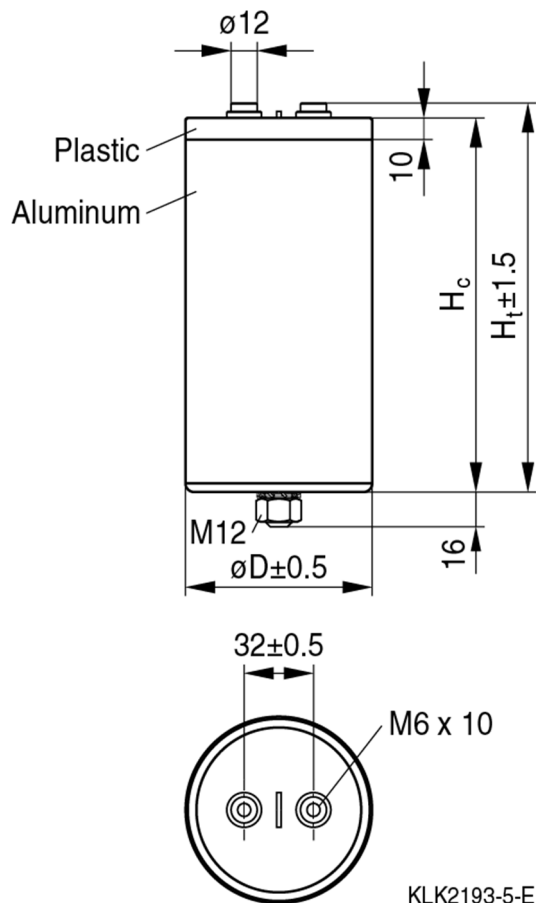
Figure 2: - B25696H – ØD = 100 mm

- Female terminals (M6)
- Between terminals 32 ± 0.5 mm

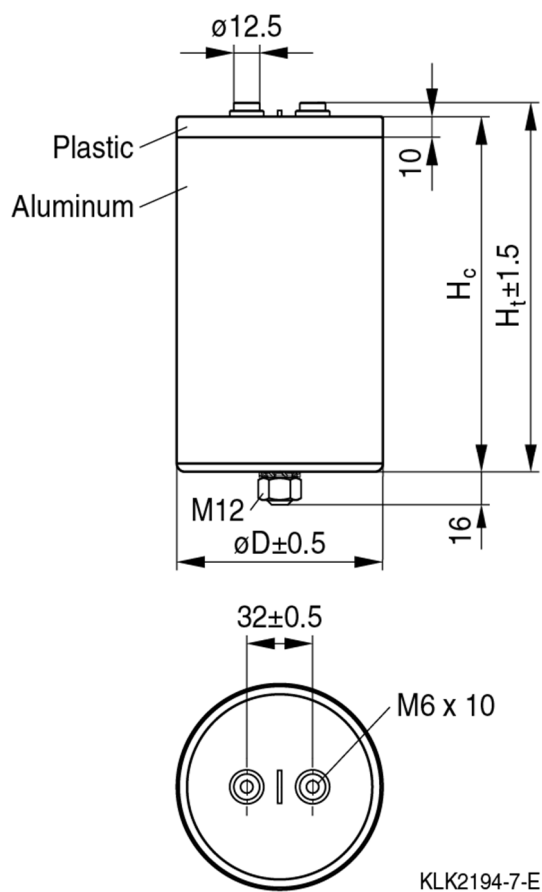

M12 stud on bottom of the aluminum case, nut (DIN 934) and toothed lock washer (DIN 6797) for fixing are standard for all types.

ØD is the diameter which close to the aluminum case bottom side about 10 mm.

Figure 3: - B25697H – ØD = 100 mm

- Female terminals (M6)

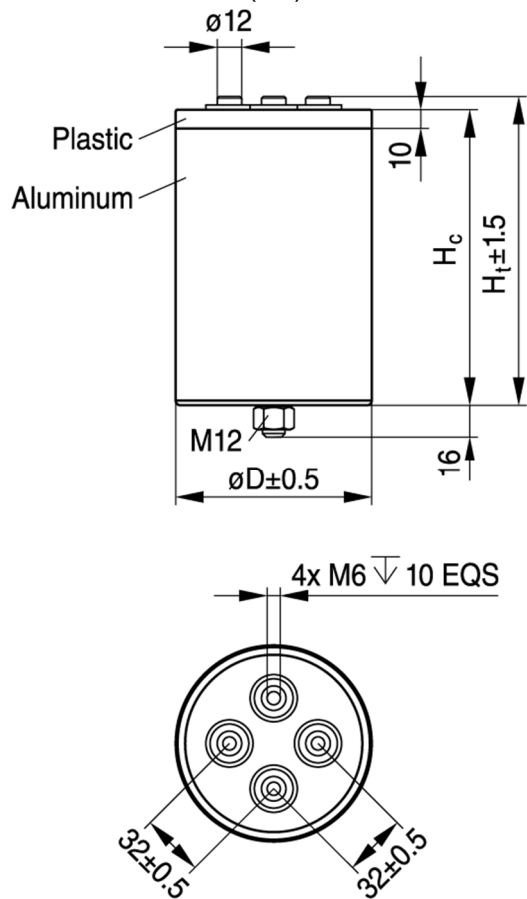

KLK2294-7-E

M12 stud on bottom of the aluminum case, nut (DIN 934) and toothed lock washer (DIN 6797) for fixing are standard for all types.

ϕD is the diameter which close to the aluminum case bottom side about 10 mm.

1.6 Clearance and Creepage distances (Typical value, Pollution degree 2)

Design	Diameter (ϕ)	Plastic ring (L)	Terminal to Terminal (mm)		Terminal to Case (mm)	
	(mm)		Clearance	Creepage	Clearance	Creepage
HF 2T	85	10	20	27.5	30.5	32
	100	10	19.5	27	37.5	39
HF 4T	100	10	19.5	32	30	36

1.7 Electrical connection diagram

The customer busbar should connect the terminals to the appropriate polarity according to the electrical connection diagram below:

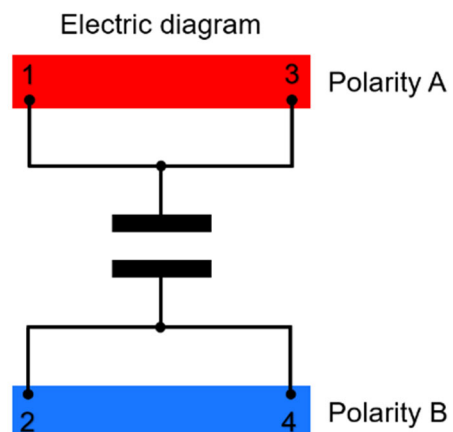
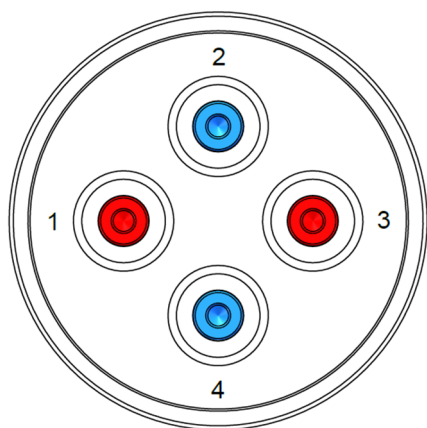

2. ESR vs Frequency

ESR at T_{amb} from 100Hz to 1MHz, ESR vs Frequency curves are based on simulation test data

ESR vs Frequency curves for capacitors $V_{R, DC} = 900$ VDC

B25696H0267K901

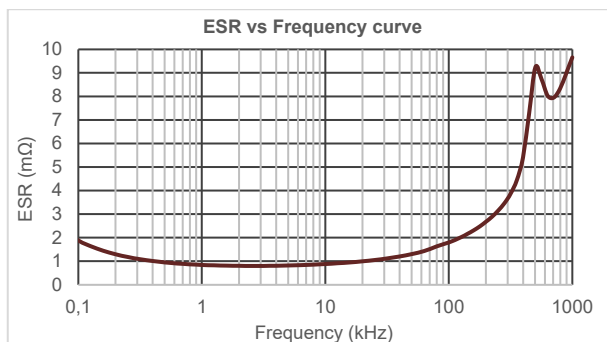

B25696H0407K901

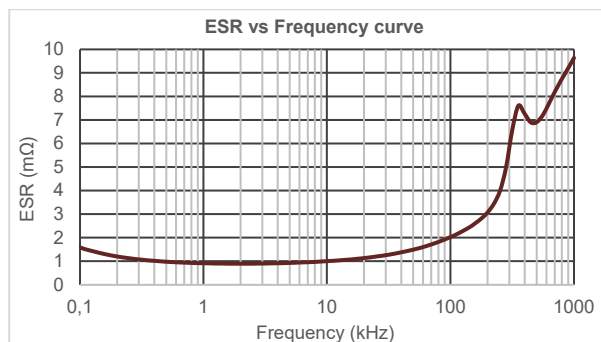

B25696H0407K911

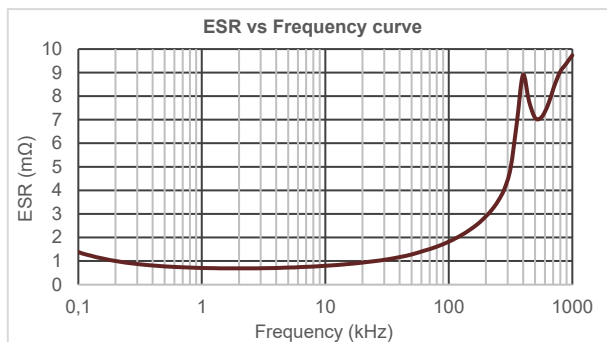

B25696H0527K901

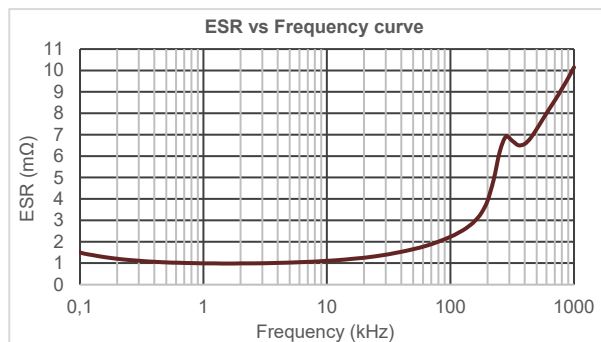

B25696H0607K901

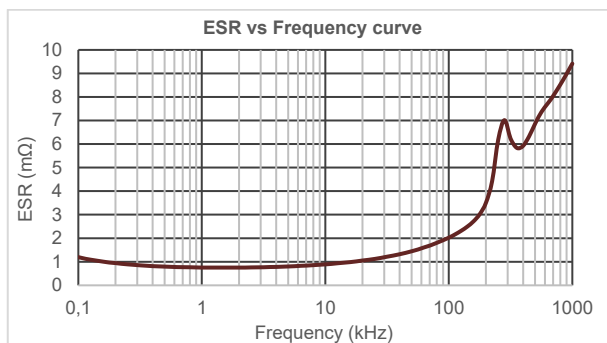

B25696H0627K901

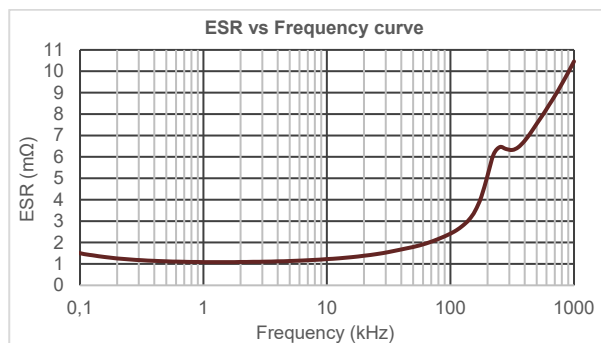

B25696H0797K901

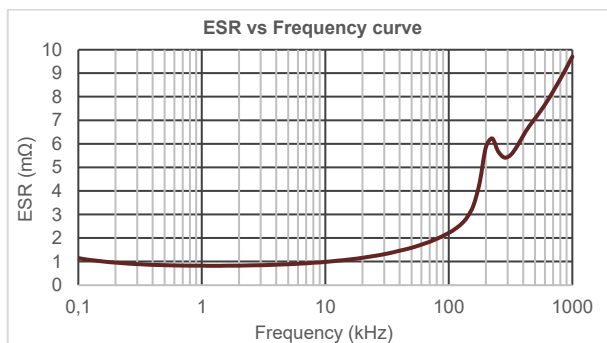

B25696H0857K901

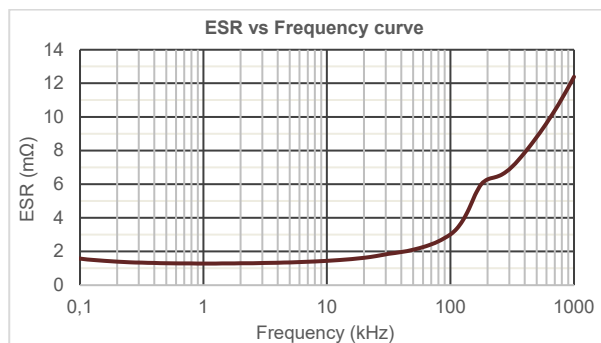

B25696H0947K901

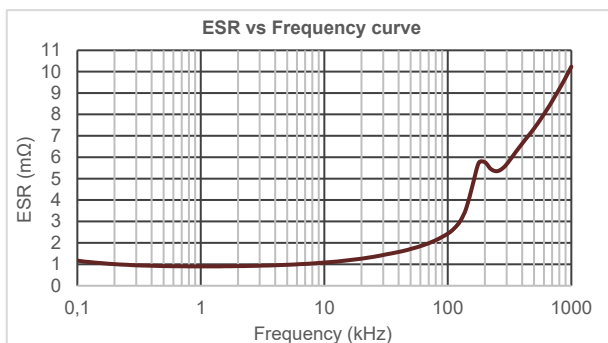

B25696H0128K901

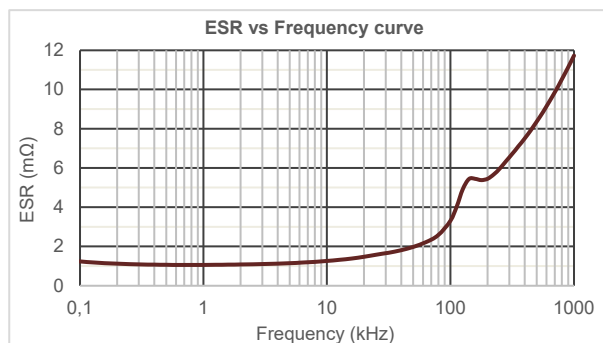

B25697H0417K901

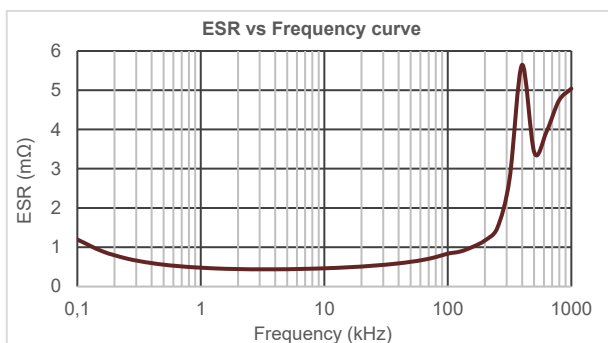

B25697H0617K901

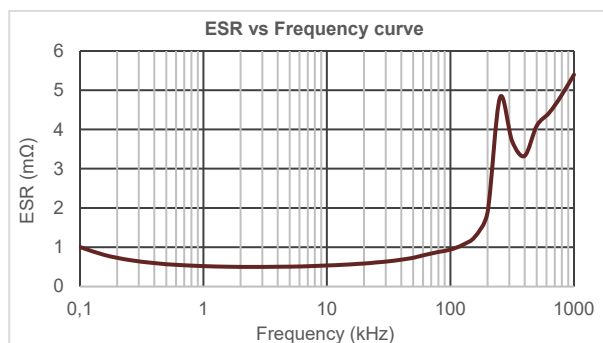

B25697H0747K901

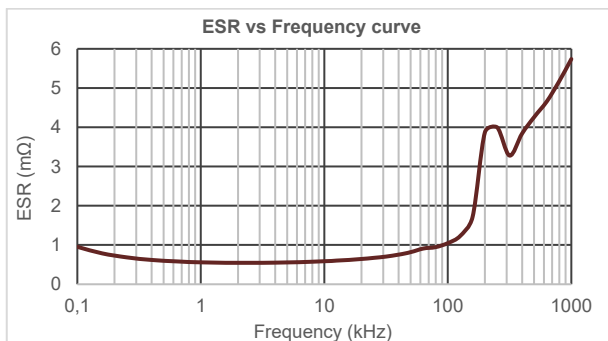

B25697H0797K901

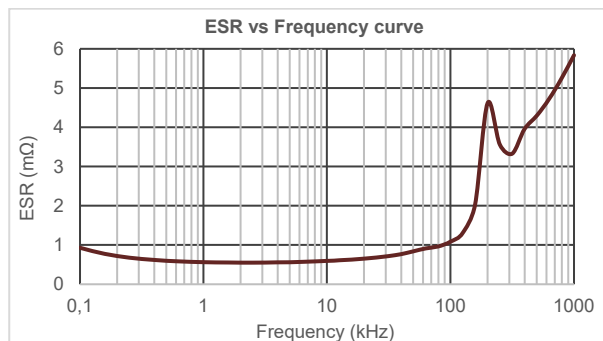

B25697H0937K901

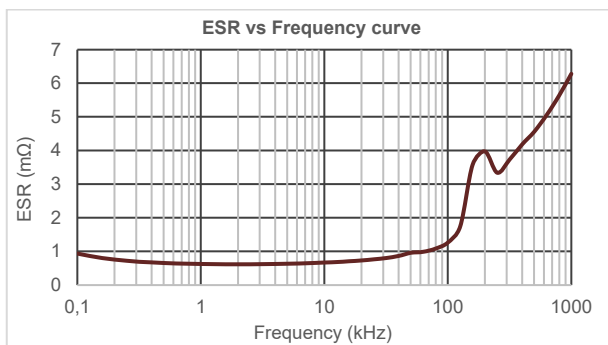

B25697H0118K901

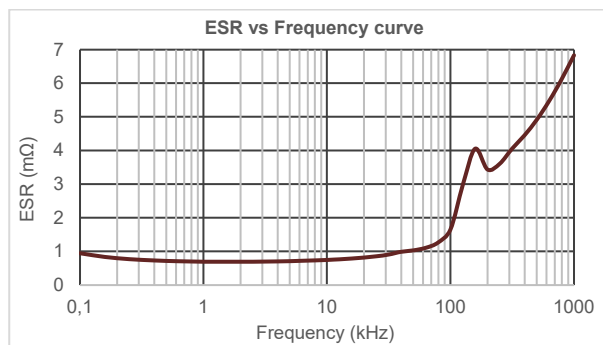

B25697H0138K901

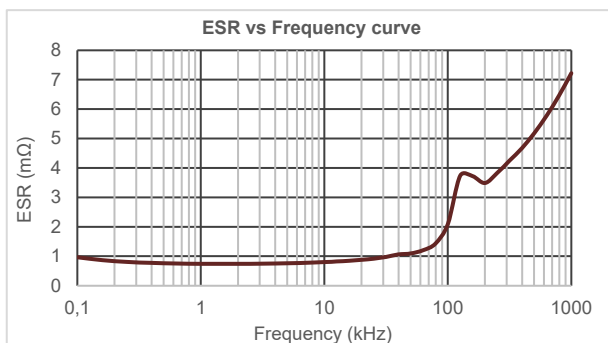

ESR vs Frequency curves for capacitors $V_{R, DC} = 1,000$ VDC

B25696H1207K001

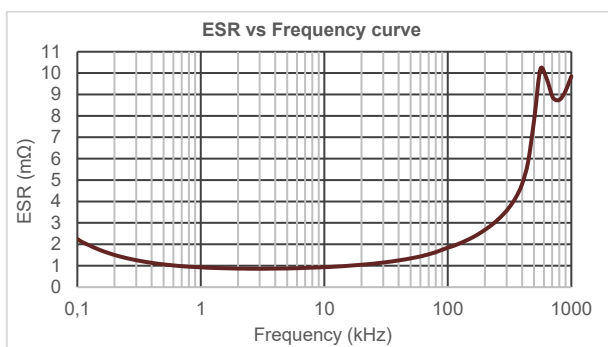

B25696H1317K001

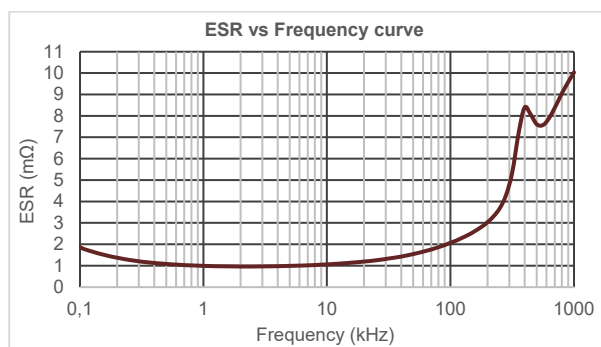

B25696H1317K011

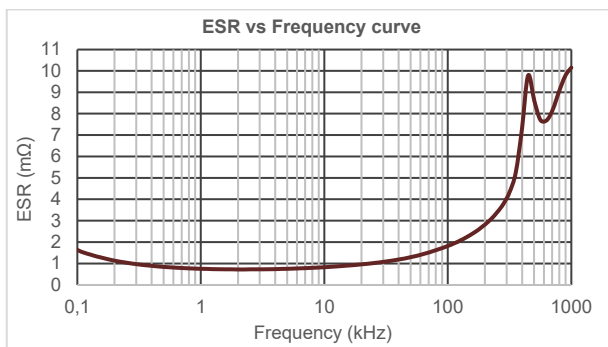

B25696H1417K001

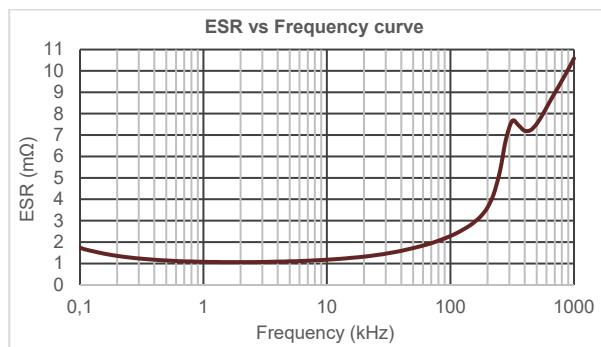

B25696H1477K001

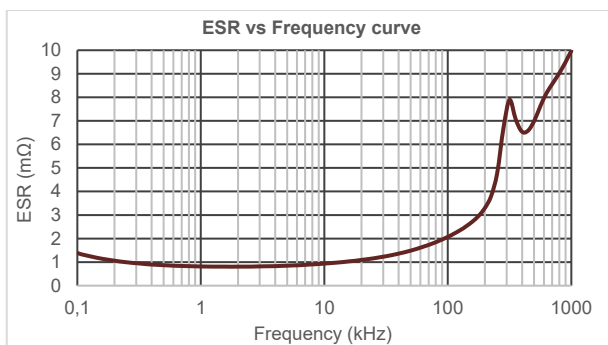

B25696H1497K001

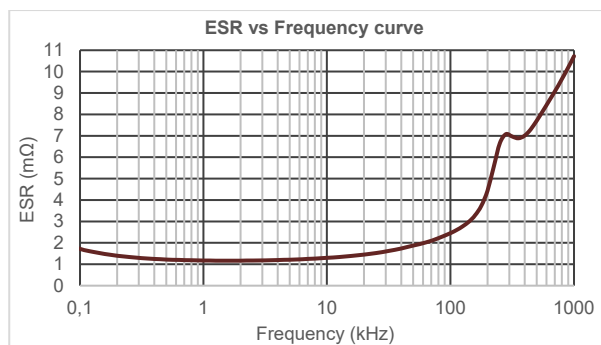

B25696H1627K001

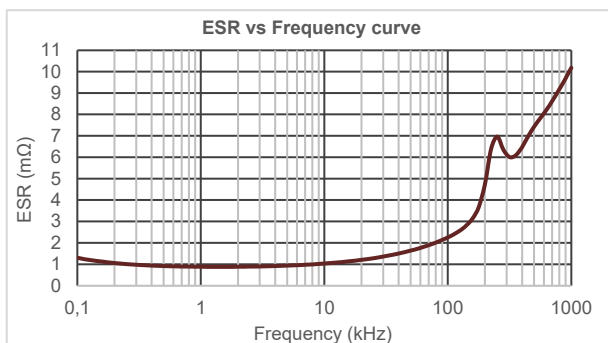

B25696H1667K001

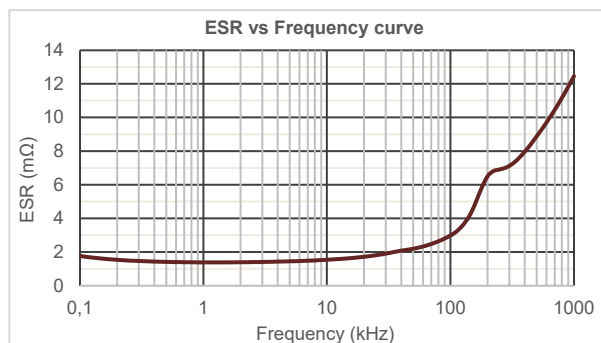

B25696H1737K001

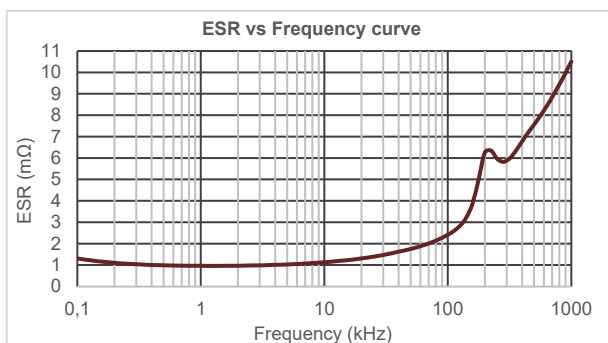

B25696H1108K001

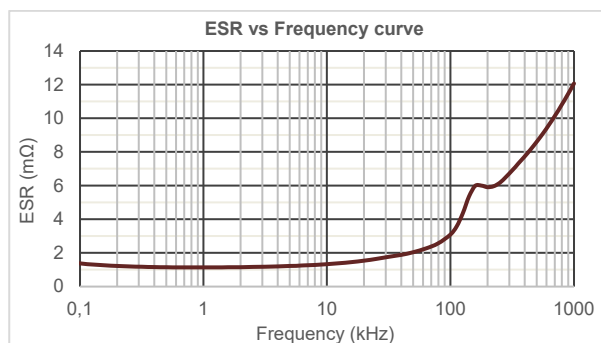

B25697H1337K001

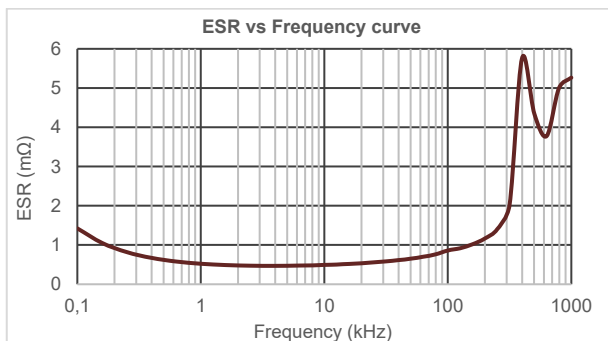

B25697H1497K001

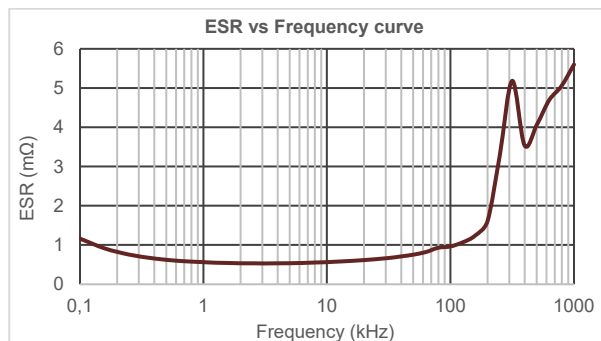

B25697H1597K001

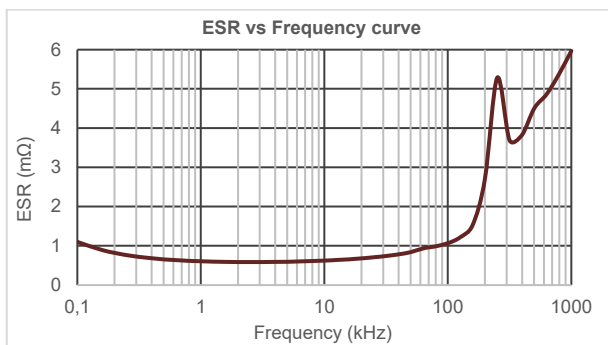

B25697H1647K001

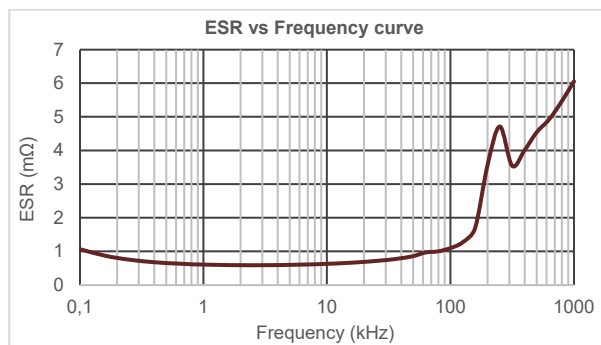

B25697H1757K001

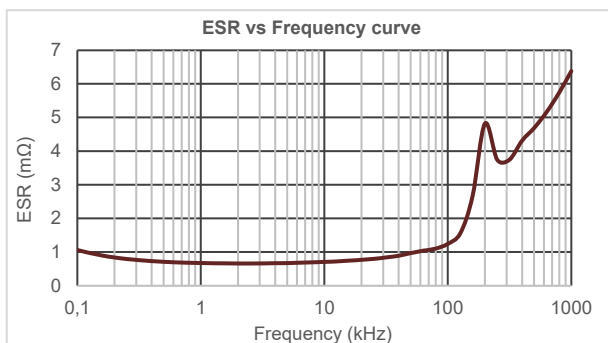

B25697H1917K001

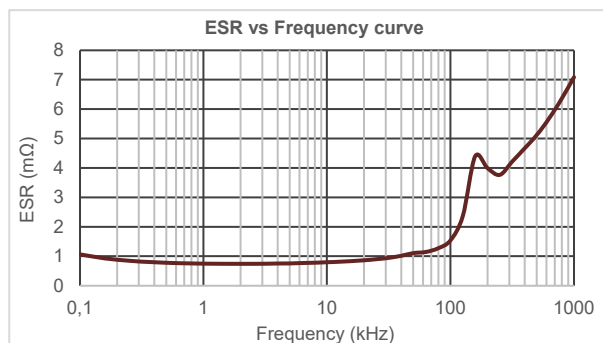

B25697H1108K001

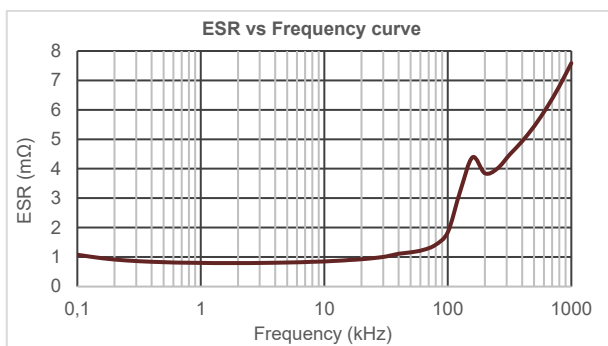

ESR vs Frequency curves for capacitors $V_{R, DC} = 1,100$ VDC

B25696H1177K101

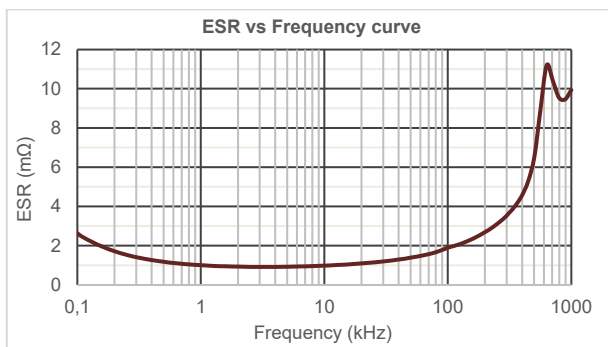

B25696H1257K101

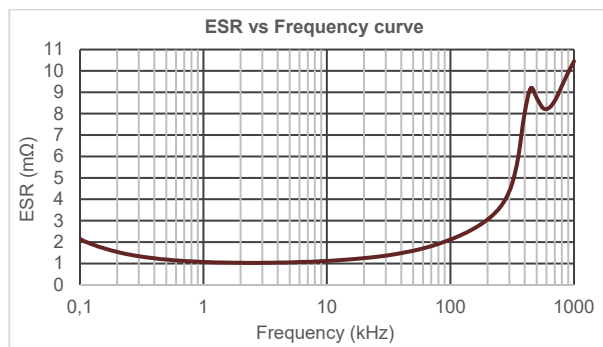

B25696H1257K111

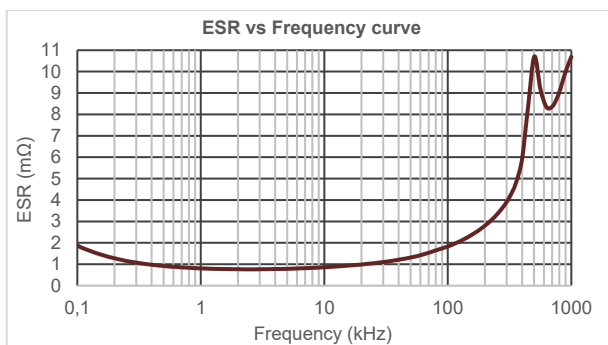

B25696H1337K101

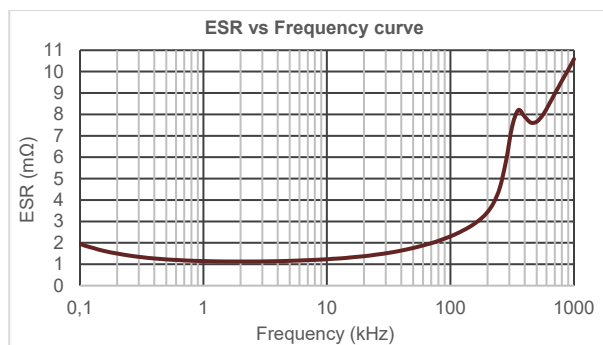

B25696H1387K101

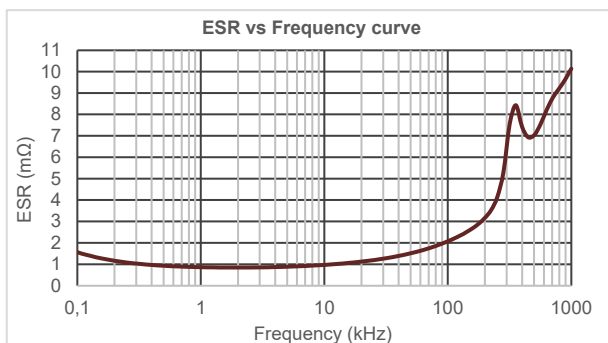

B25696H1407K101

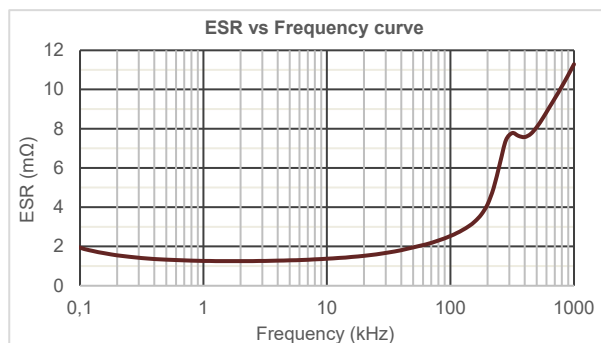

B25696H1507K101

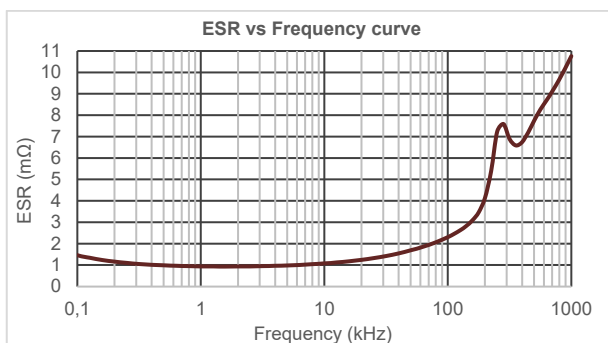

B25696H1547K101

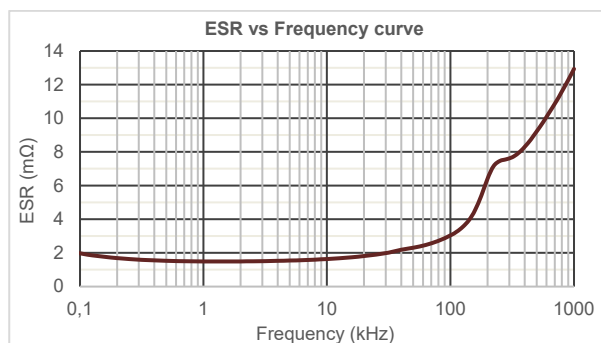

B25696H1607K101

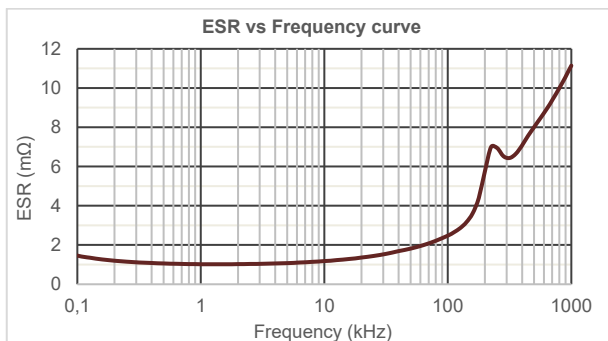

B25696H1827K101

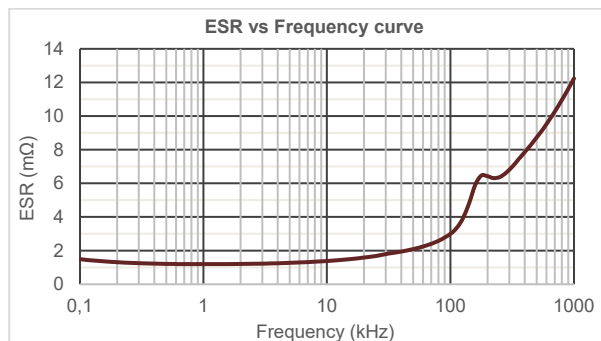

B25697H1277K101

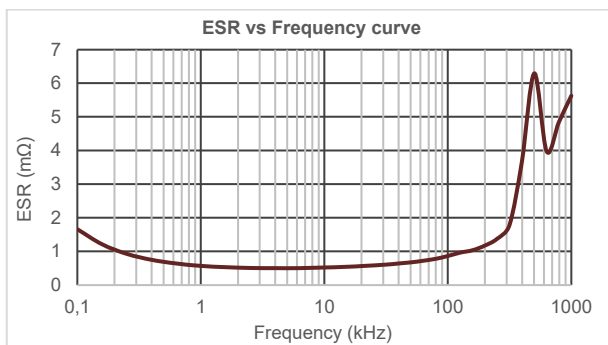

B25697H1407K101

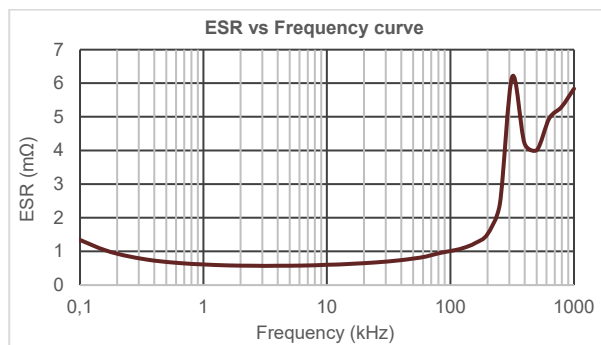

B25697H1497K101

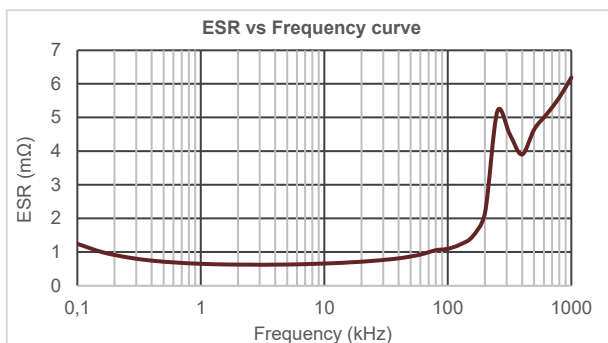

B25697H1537K101

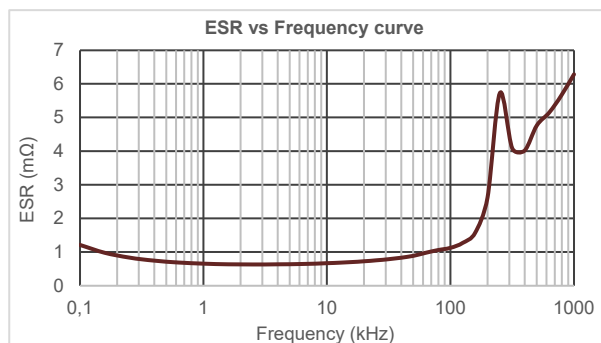

B25697H1627K101

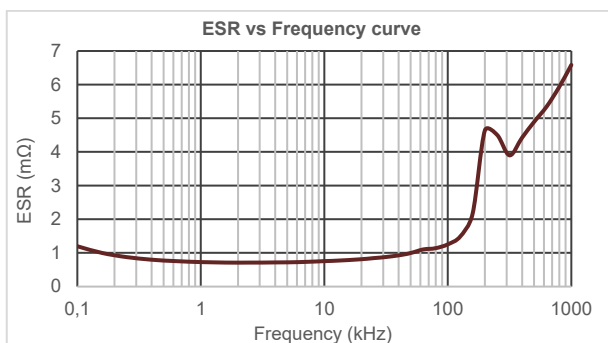

B25697H1767K101

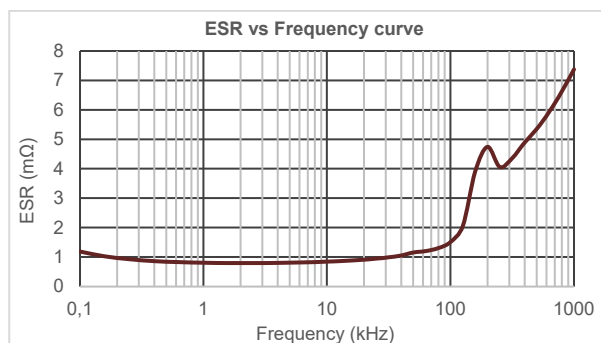

B25697H1847K101

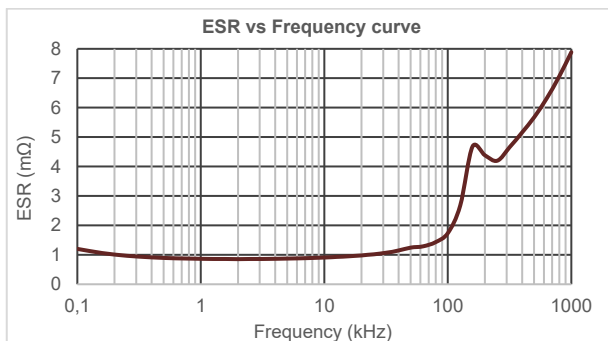

ESR vs Frequency curves for capacitors $V_{R, DC} = 1,200$ VDC

B25696H1127K201

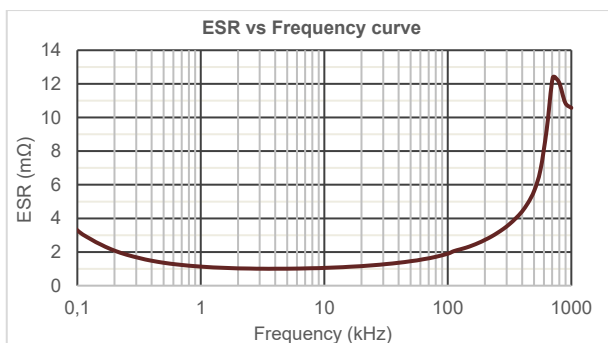

B25696H1197K201

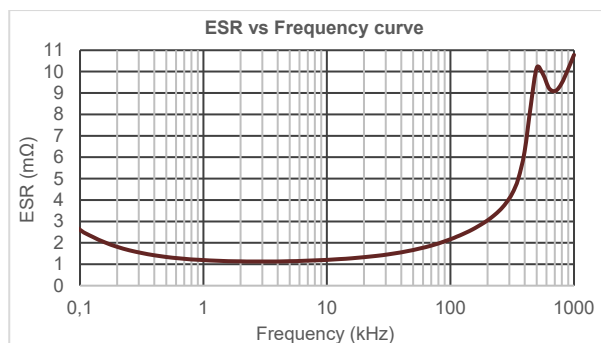

B25696H1197K211

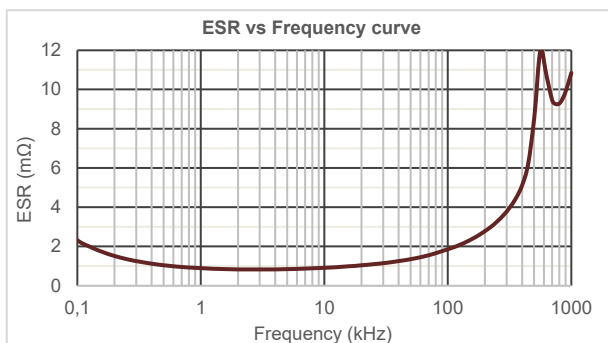

B25696H1257K201

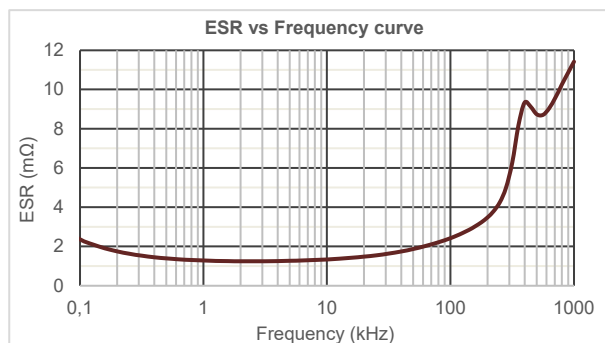

B25696H1297K201

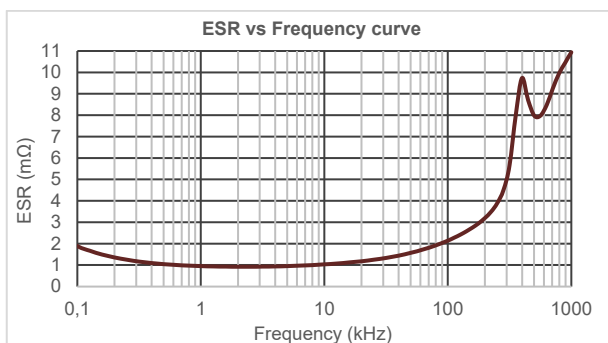

B25696H1307K201

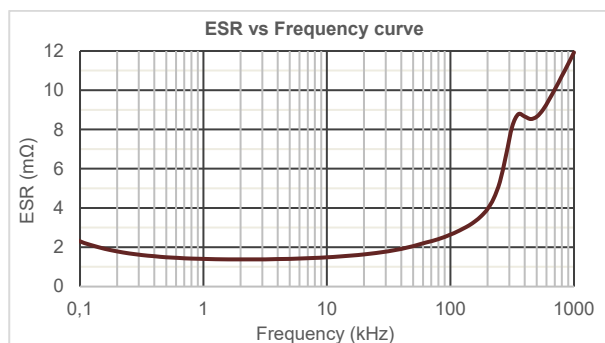

B25696H1387K201

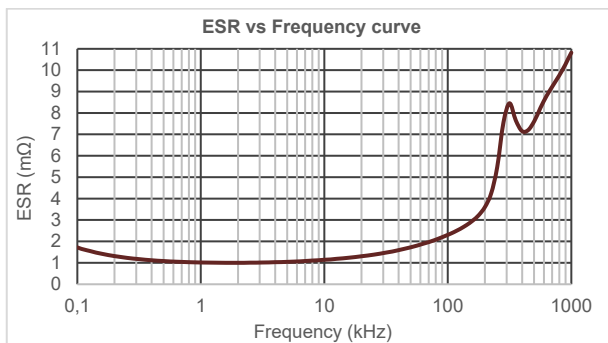

B25696H1417K201

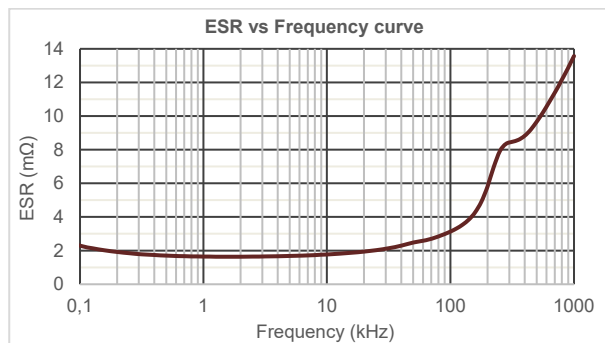

B25696H1457K201

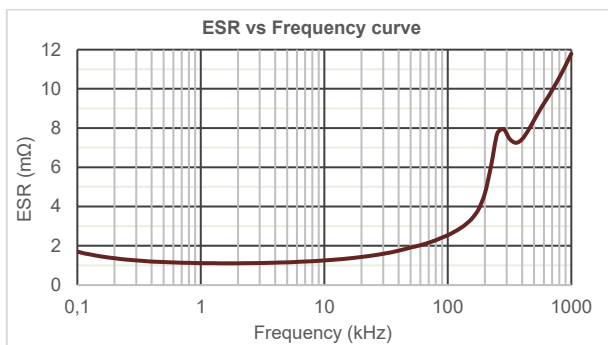

B25696H1627K201

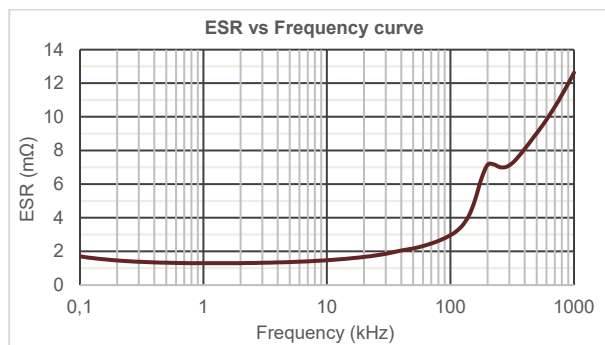

B25697H1227K201

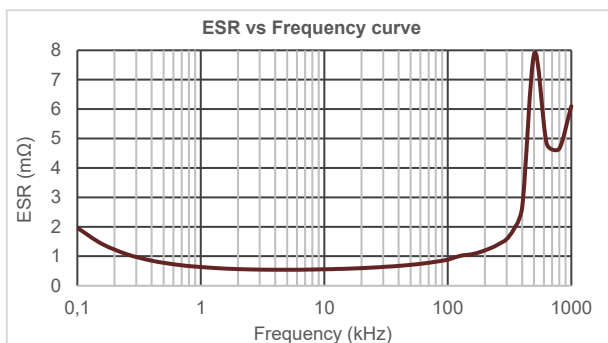

B25697H1337K201

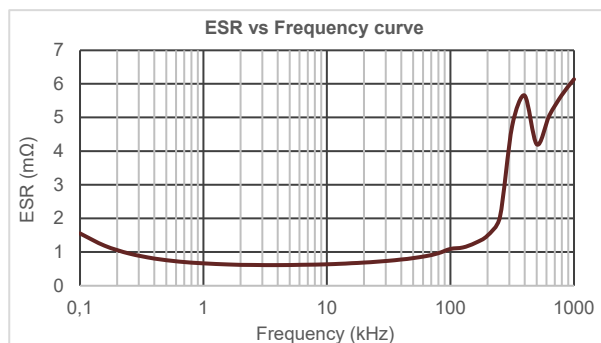

B25697H1407K201

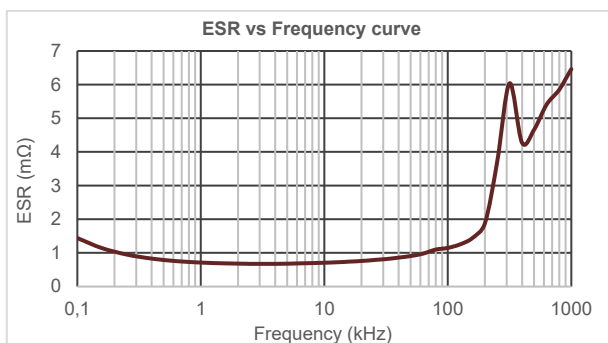

B25697H1437K201

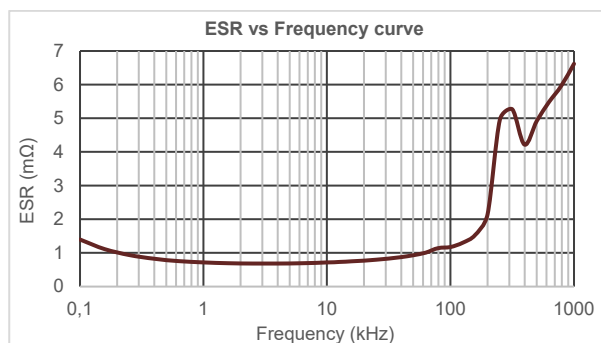

B25697H1517K201

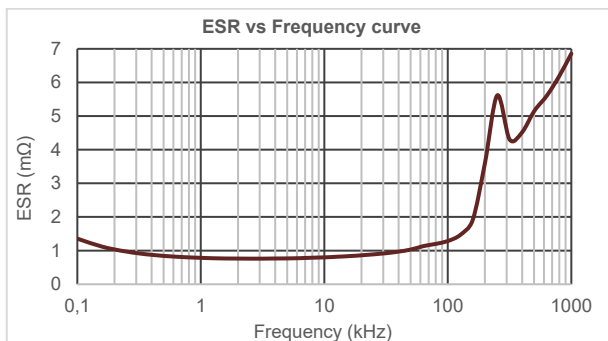

B25697H1627K201

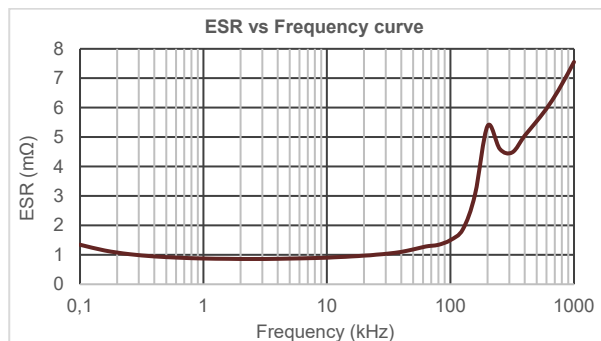

B25697H1697K201

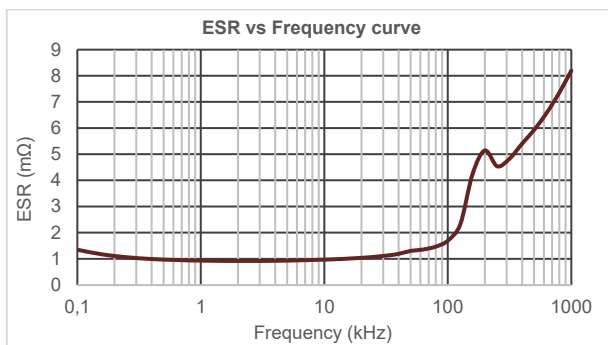

ESR vs Frequency curves for capacitors $V_{R, DC} = 1,300$ VDC

B25696H1107K301

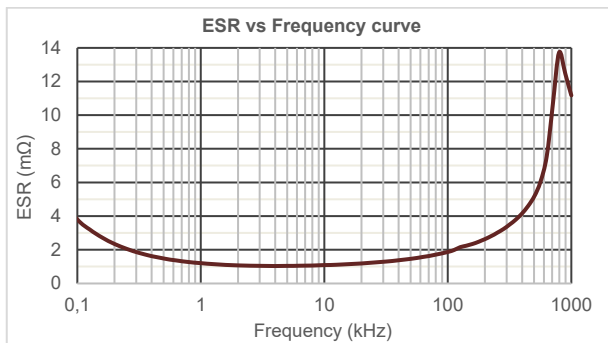

B25696H1167K311

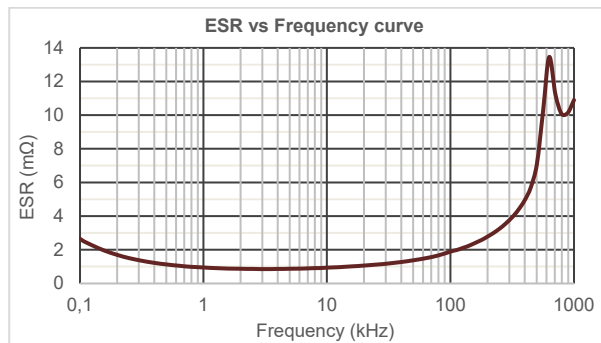

B25696H1167K301

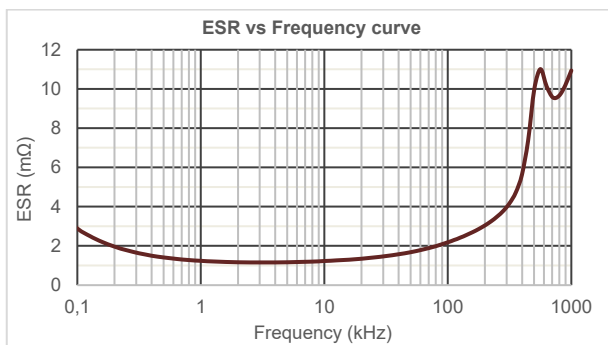

B25696H1227K301

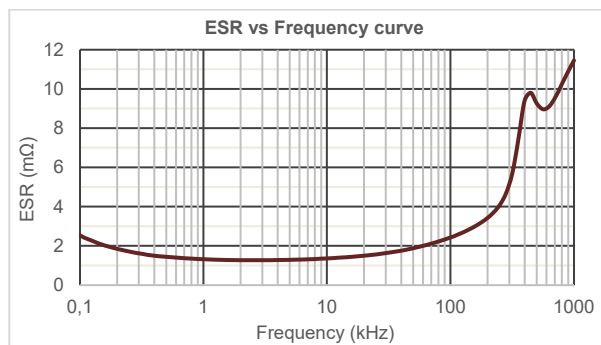

B25696H1257K301

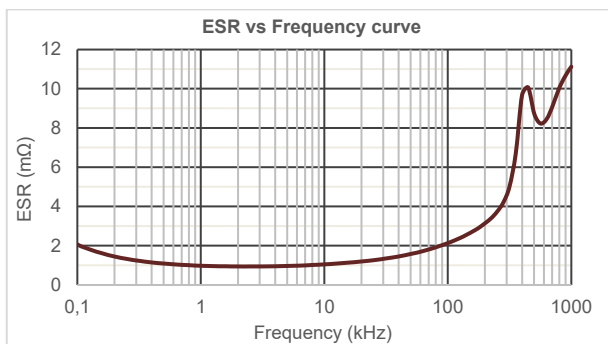

B25696H1267K301

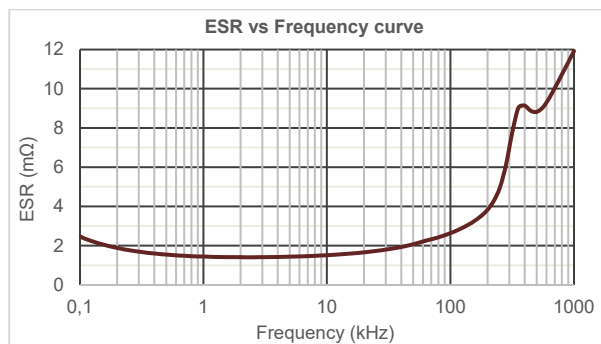

B25696H1337K301

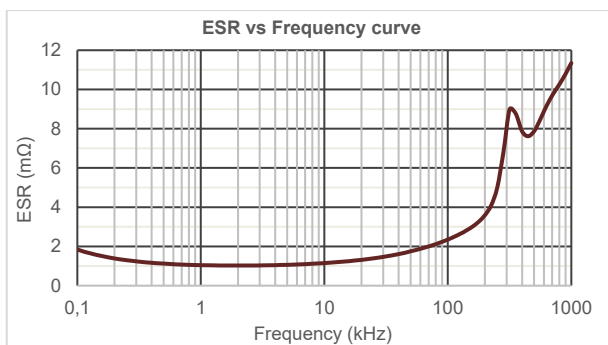

B25696H1367K301

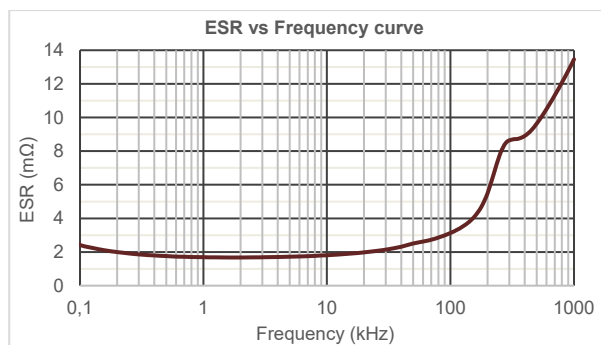

B25696H1407K301

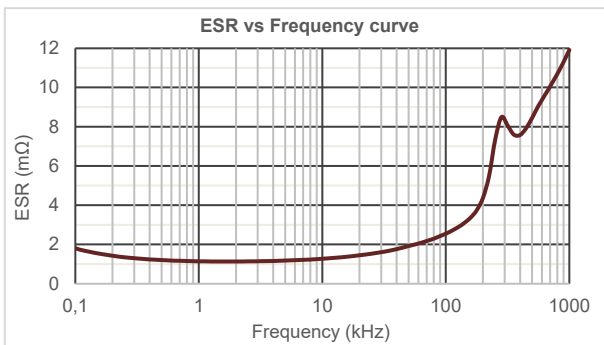

B25696H1557K301

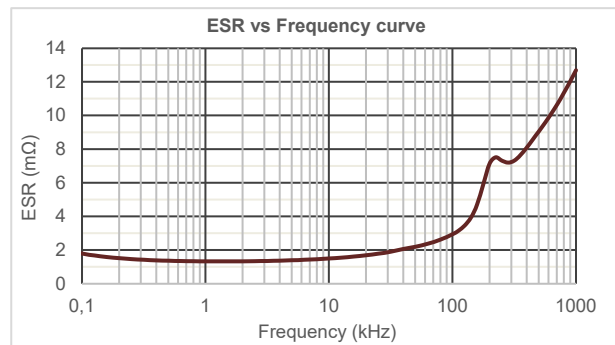

B25697H1197K301

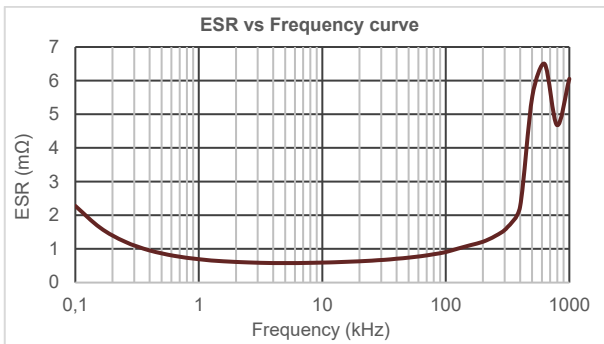

B25697H1287K301

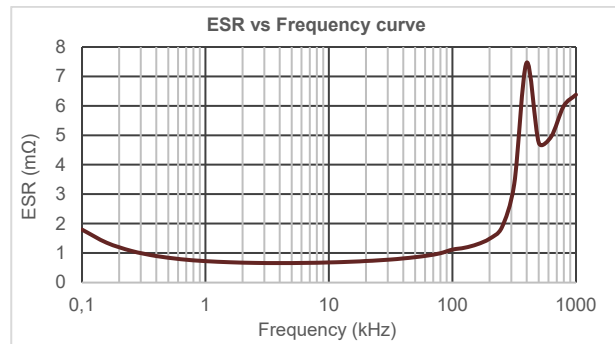

B25697H1347K301

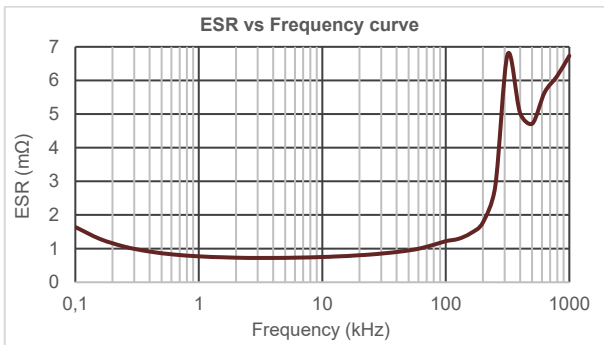

B25697H1367K301

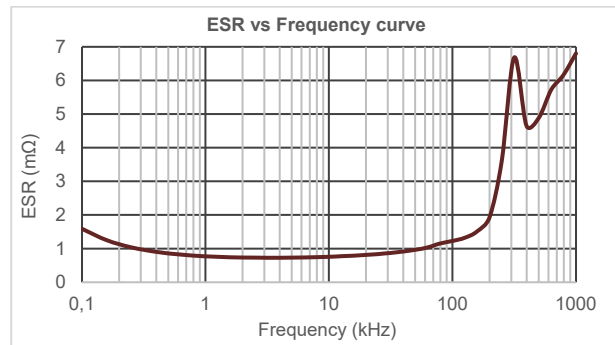

B25697H1437K301

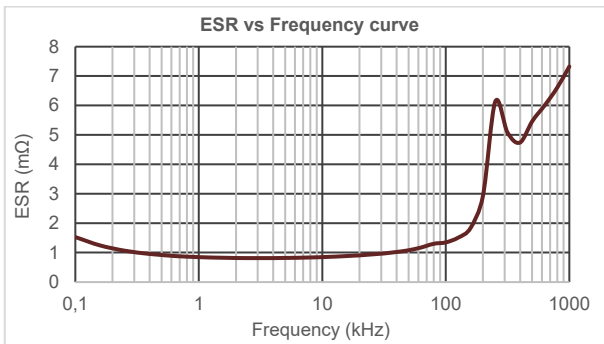

B25697H1527K301

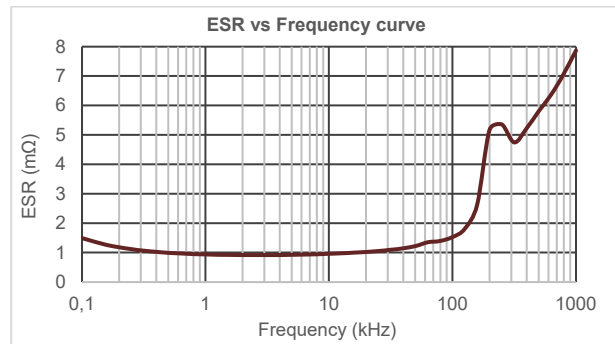

B25697H1587K301

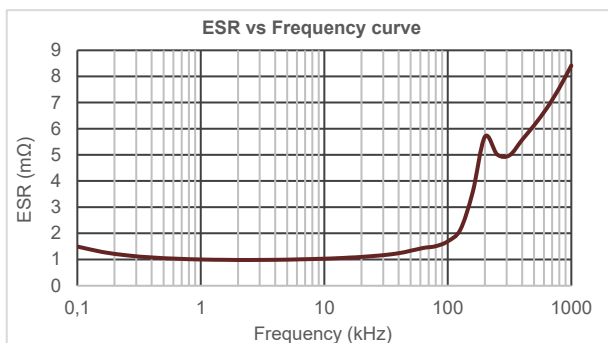

ESR vs Frequency curves for capacitors $V_{R, DC} = 1,500 \text{ VDC}$

B25696H1926K501

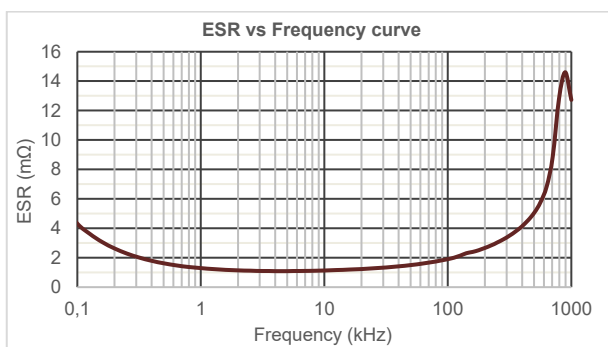

B25696H1137K501

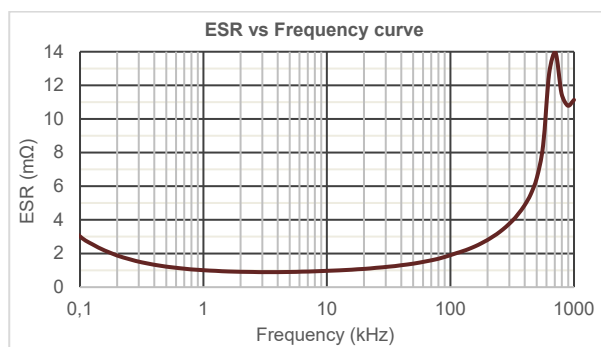

B25696H1147K501

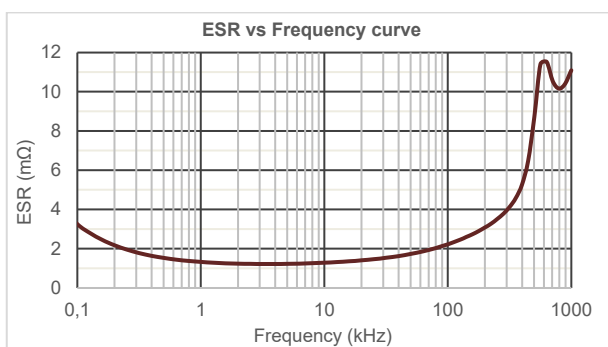

B25696H1197K501

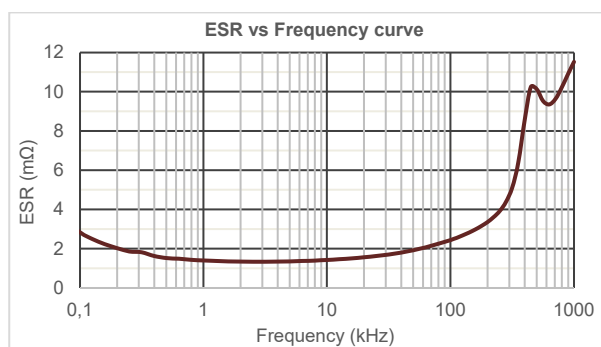

B25696H1217K501

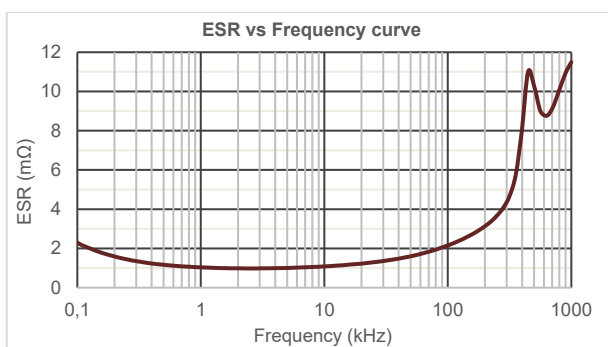

B25696H1227K501

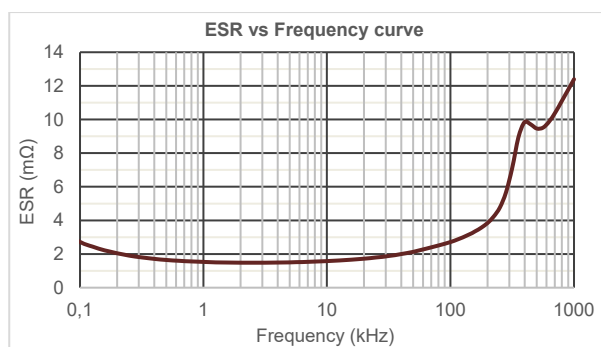

B25696H1287K501

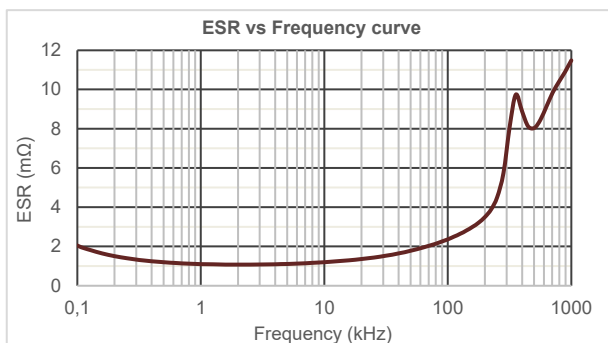

B25696H1317K501

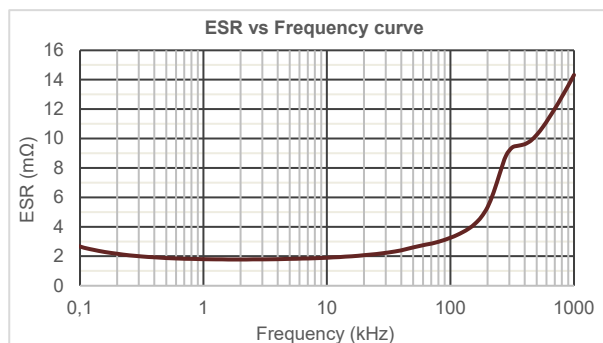

B25696H1347K501

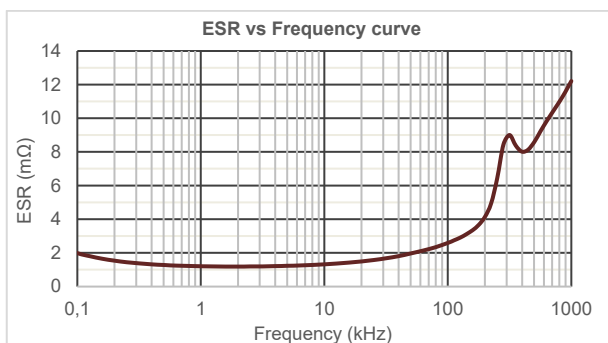

B25696H1477K501

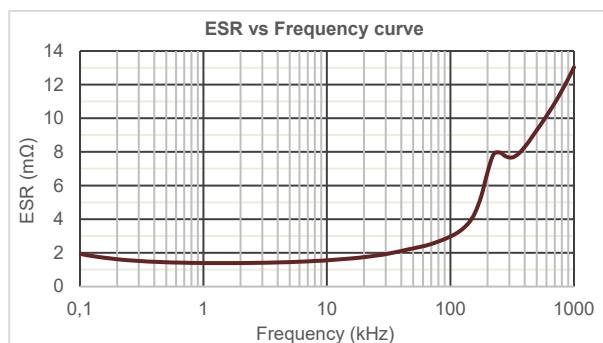

B25697H1157K501

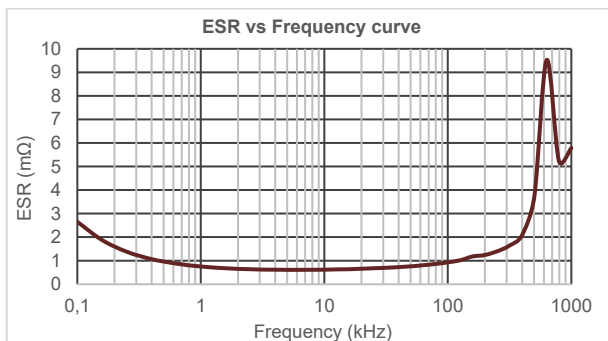

B25697H1237K501

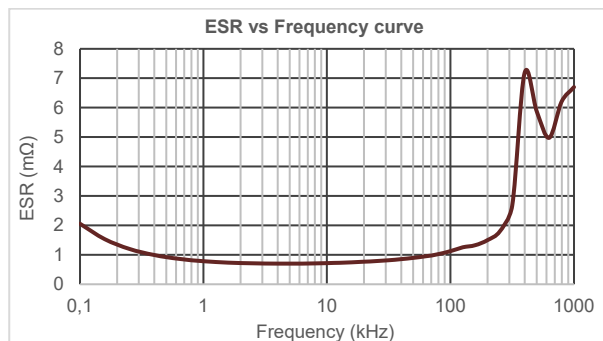

B25697H1297K501

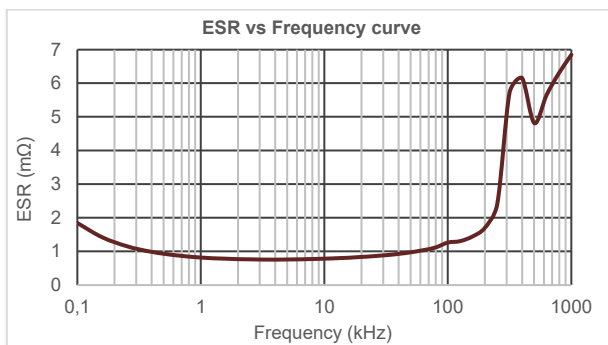

B25697H1317K501

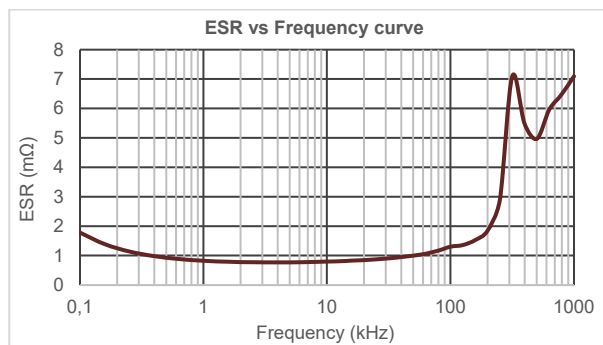

B25697H1367K501

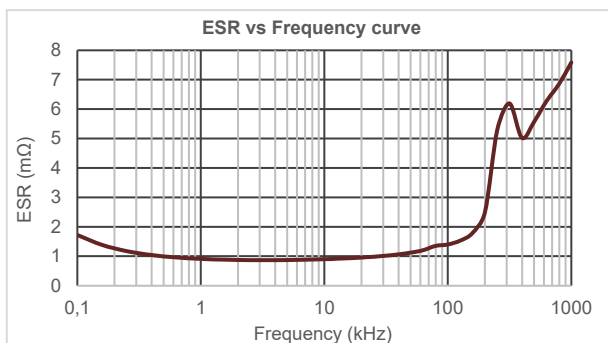

B25697H1447K501

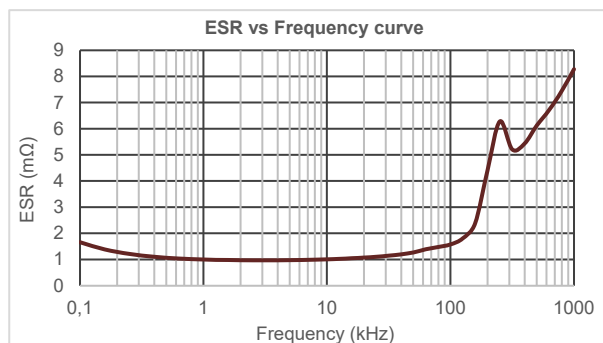

B25697H1497K501

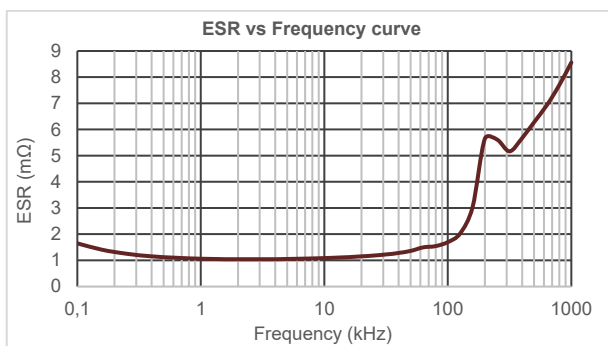

ESR vs Frequency curves for capacitors $V_{R, DC} = 1,600$ VDC

B25696H1806K601

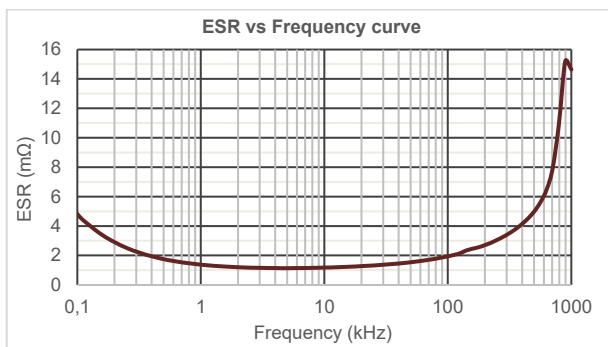

B25696H1127K611

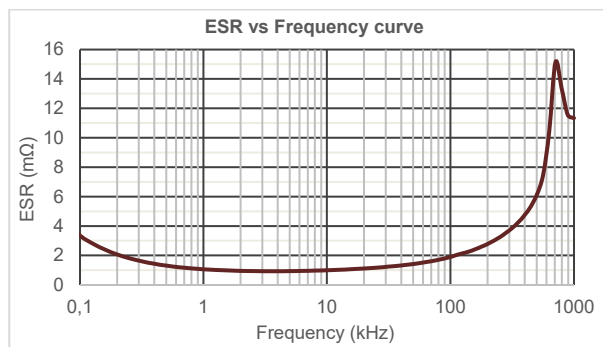

B25696H1127K601

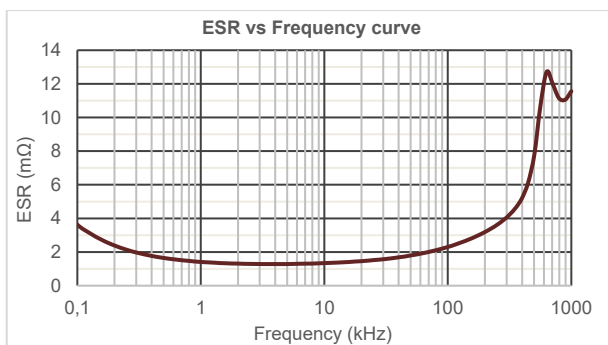

B25696H1167K601

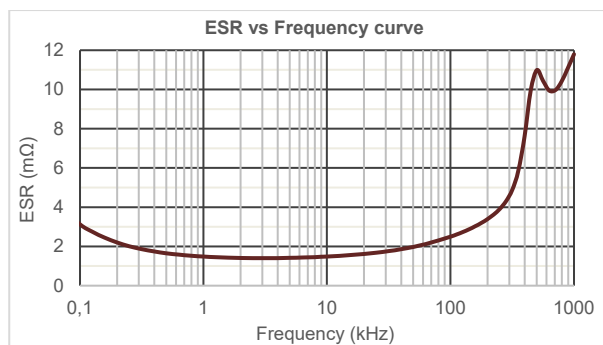

B25696H1187K601

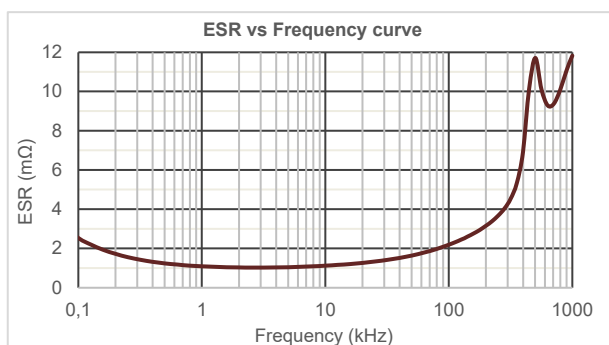

B25696H1207K601

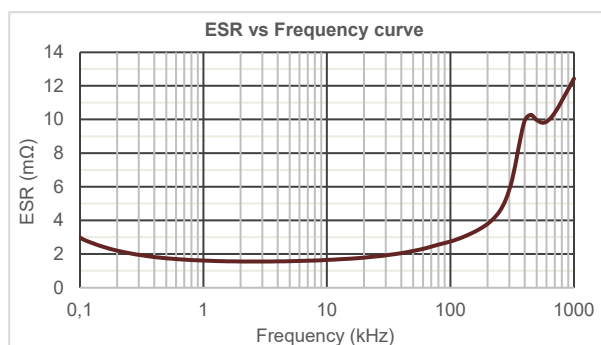

B25696H1257K601

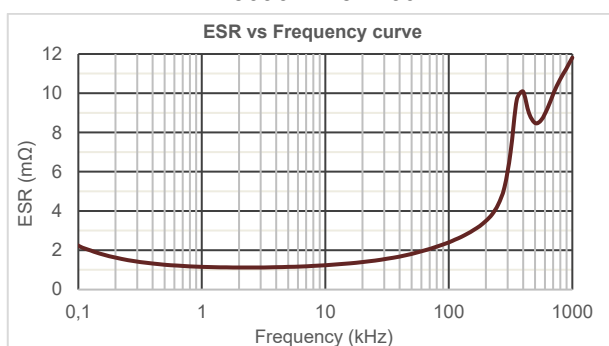

B25696H1277K601

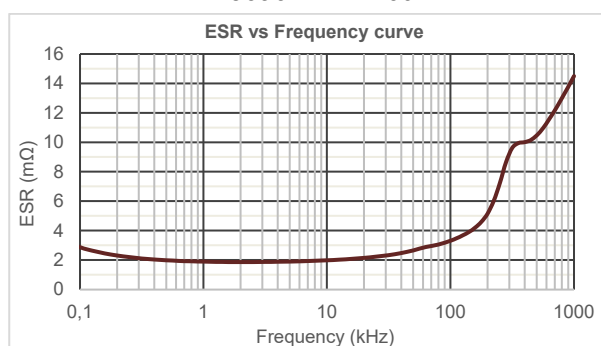

B25696H1307K601

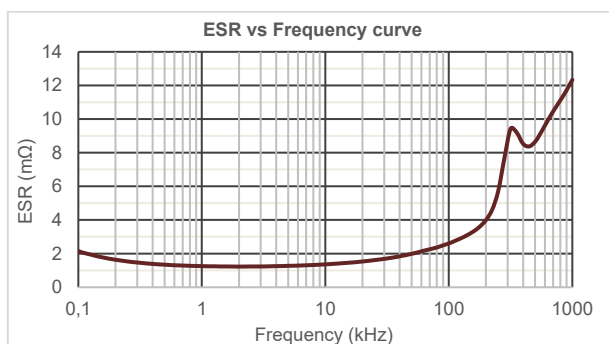

B25696H1417K601

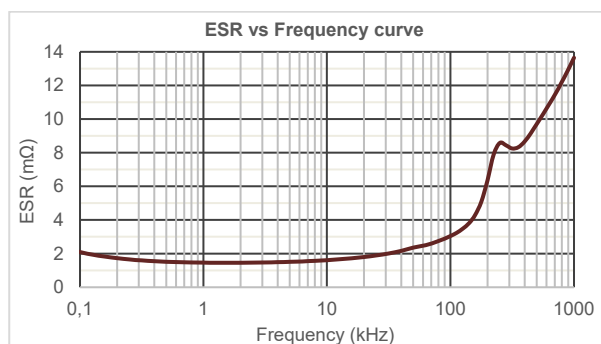

B25697H1137K601

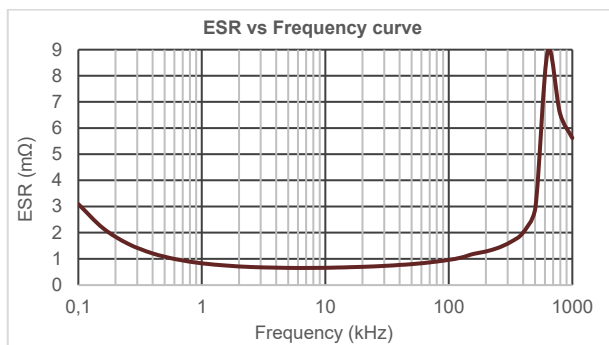

B25697H1207K601

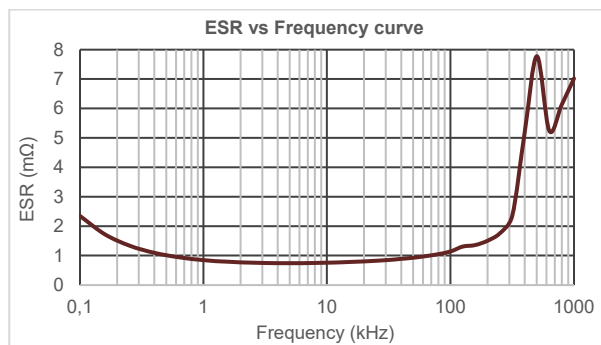

B25697H1247K601

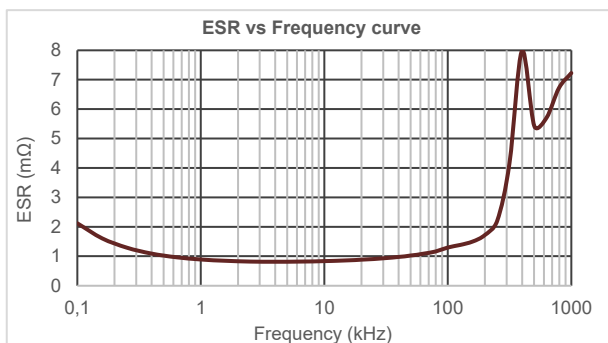

B25697H1267K601

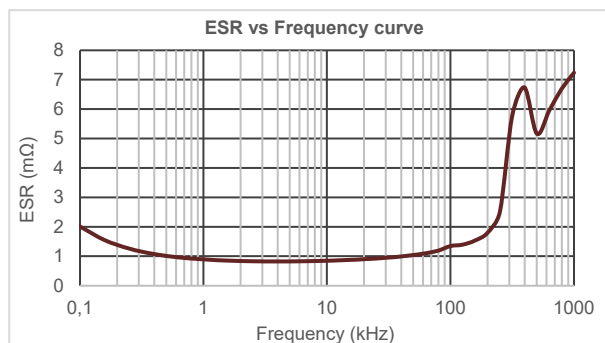

B25697H1317K601

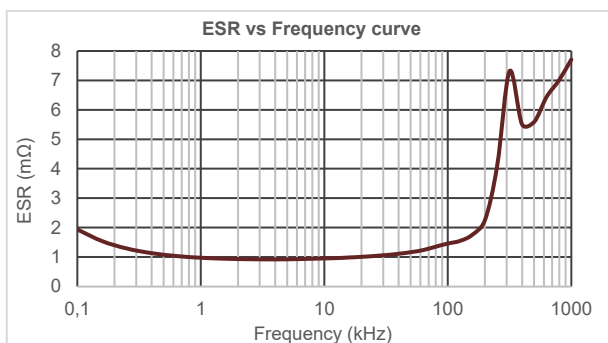

B25697H1377K601

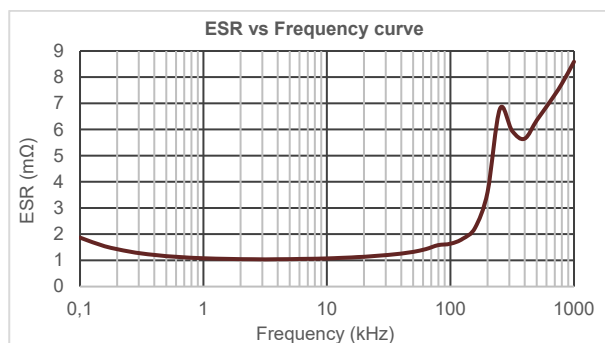

B25697H1417K601

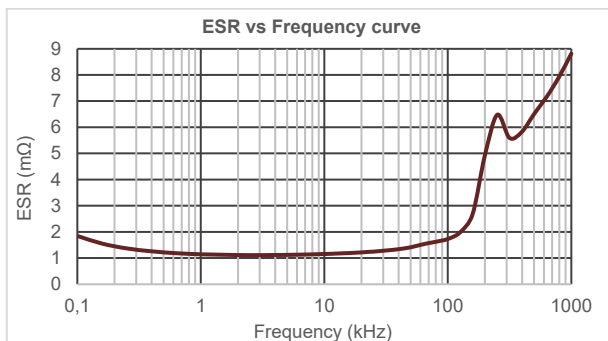

ESR vs Frequency curves for capacitors $V_{R, DC} = 1,700$ VDC

B25696H1676K701

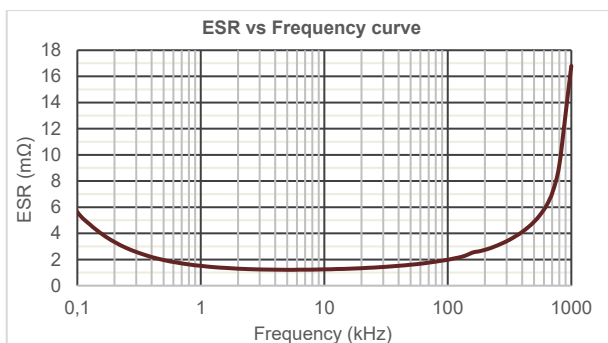

B25696H1107K711

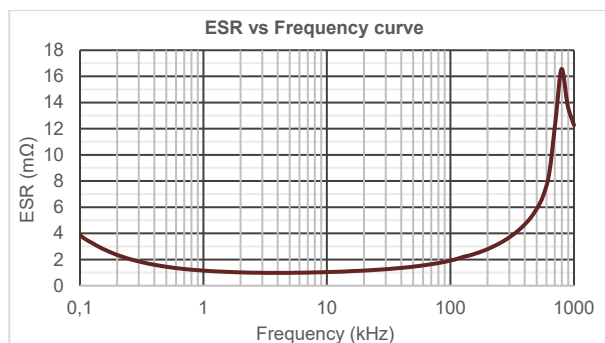

B25696H1107K701

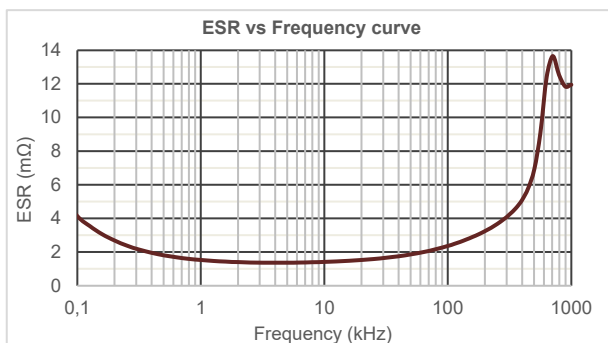

B25696H1147K701

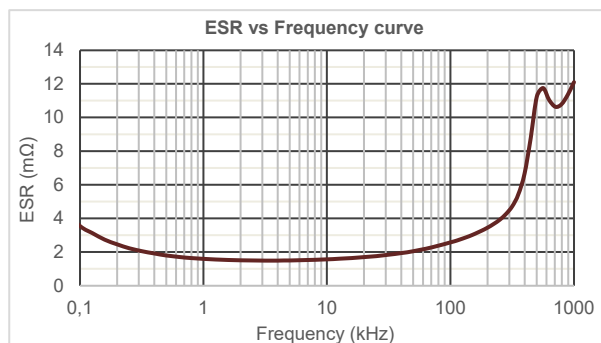

B25696H1157K701

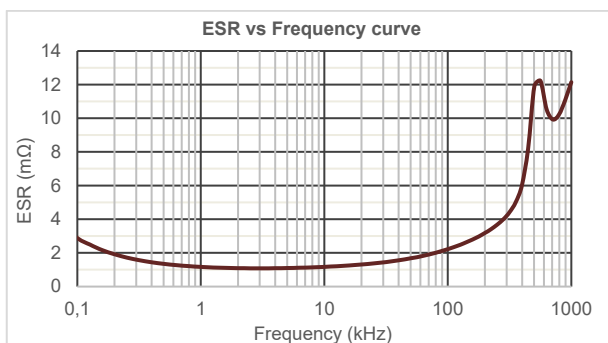

B25696H1167K701

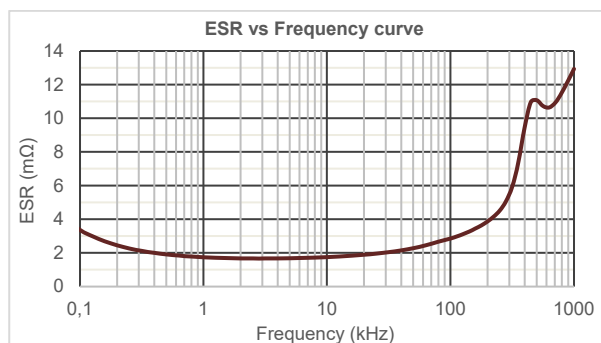

B25696H1217K701

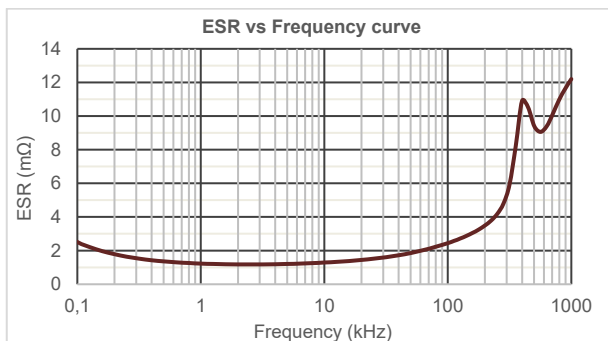

B25696H1237K701

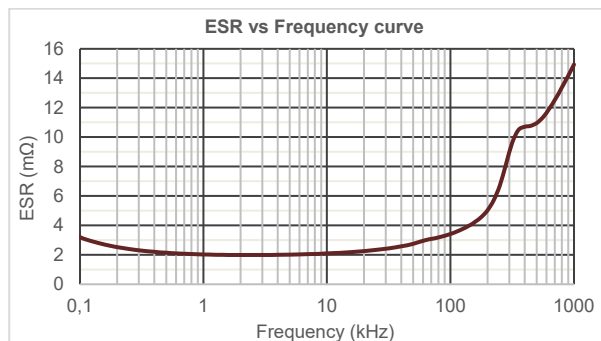

B25696H1257K701

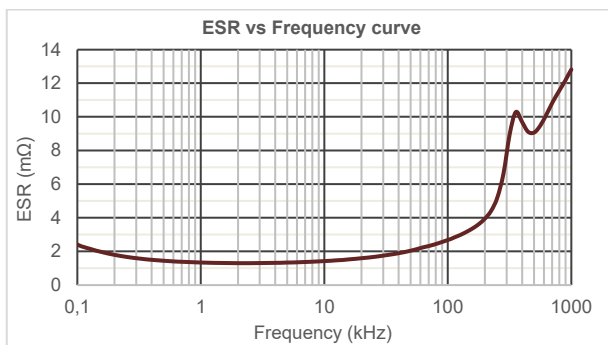

B25696H1357K701

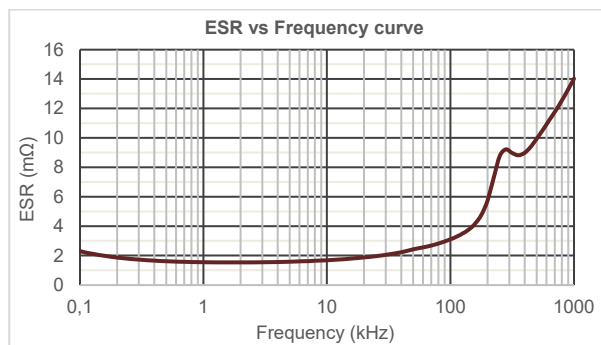

B25697H1117K701

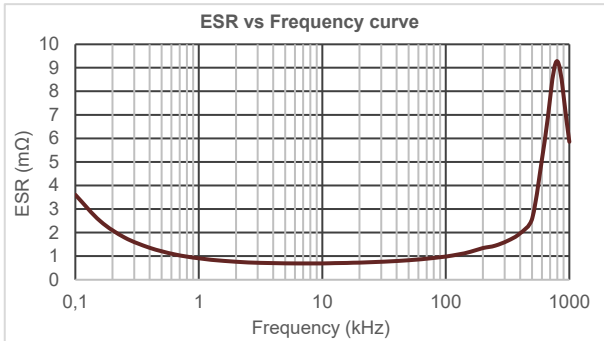

B25697H1177K701

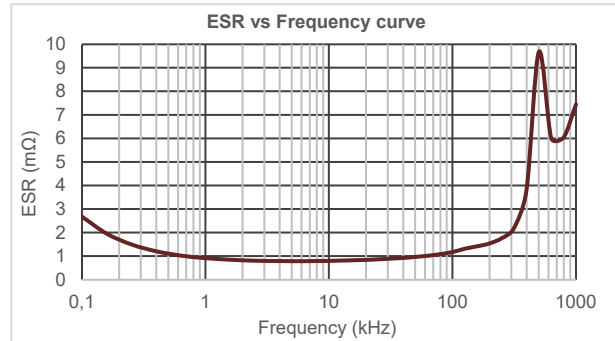

B25697H1207K701

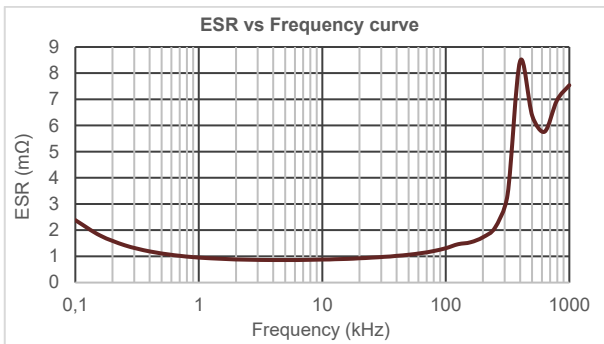

B25697H1227K701

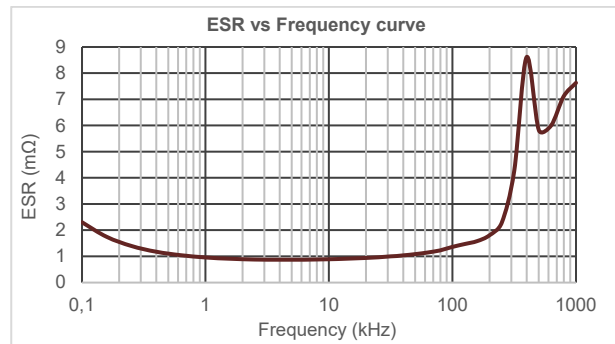

B25697H1267K701

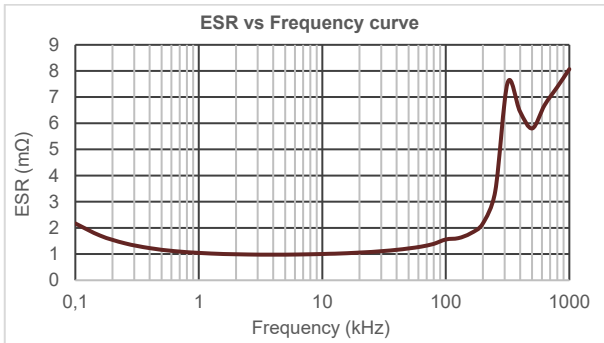

B25697H1327K701

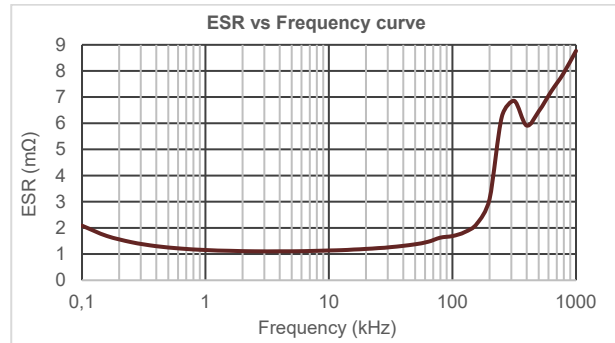

B25697H1367K701

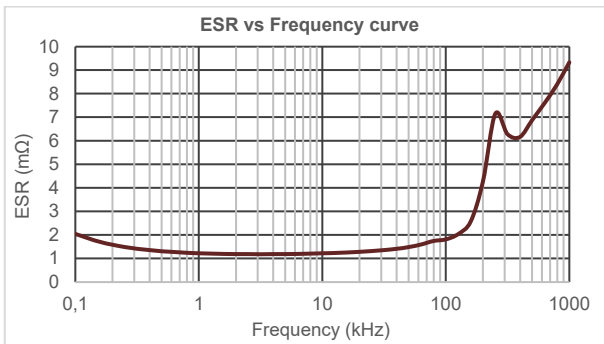

ESR vs Frequency curves for capacitors $V_{R, DC} = 1,800$ VDC

B25696H1606K801

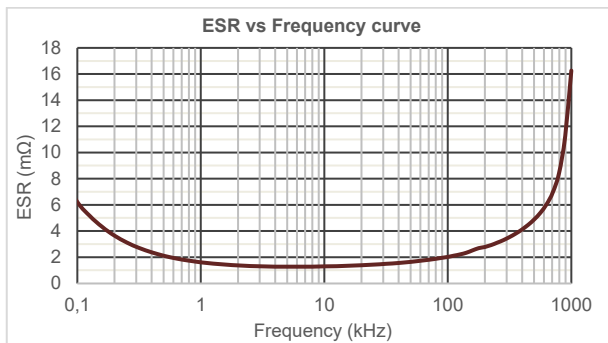

B25696H1916K801

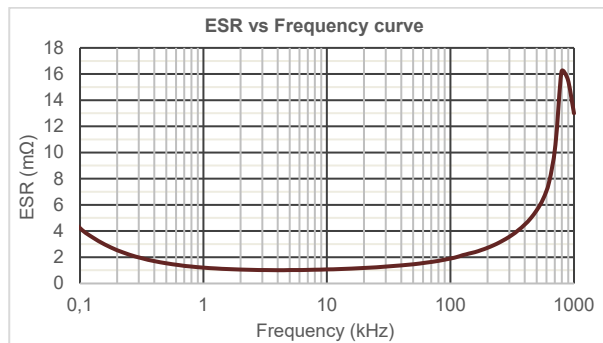

B25696H1946K801

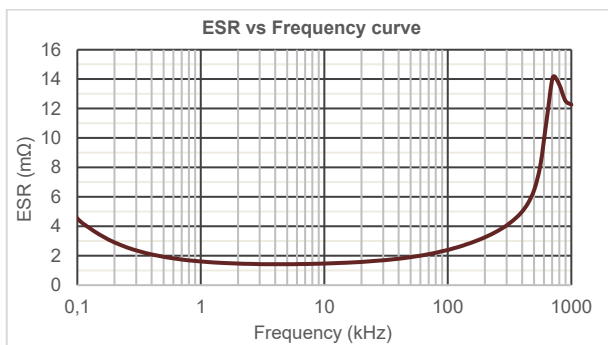

B25696H1127K801

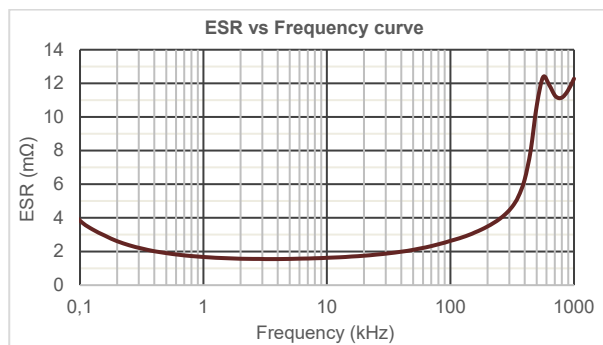

B25696H1147K801

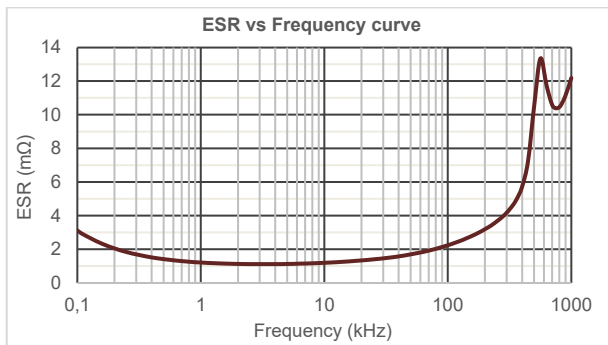

B25696H1157K801

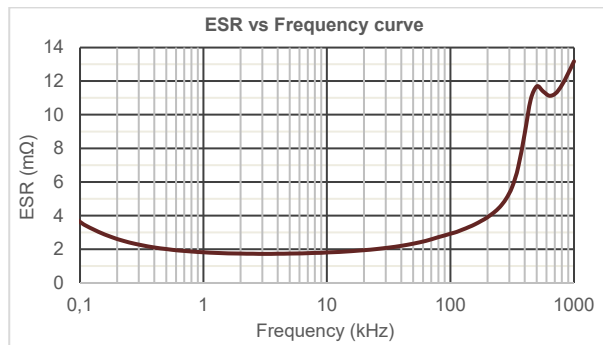

B25696H1197K801

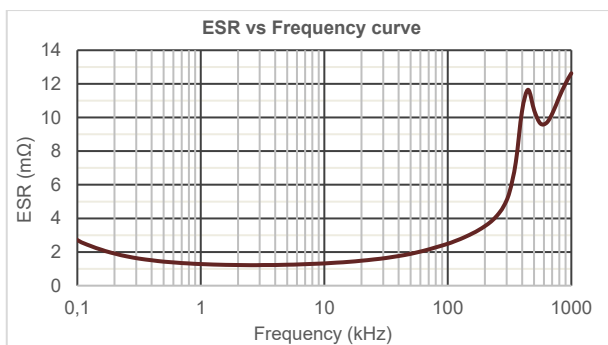

B25696H1207K801

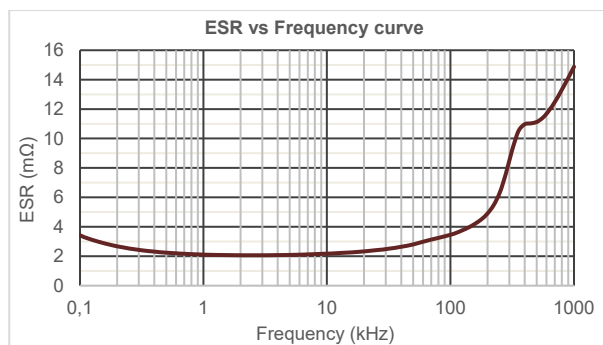

B25696H1227K801

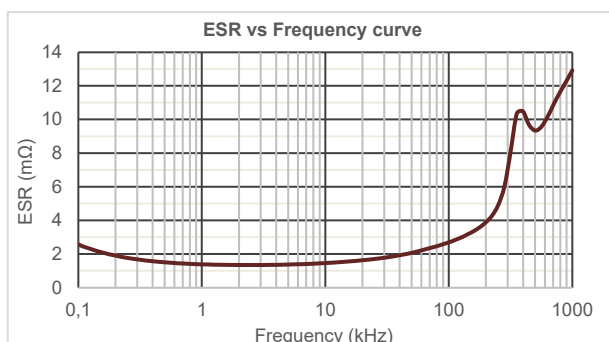

B25696H1317K801

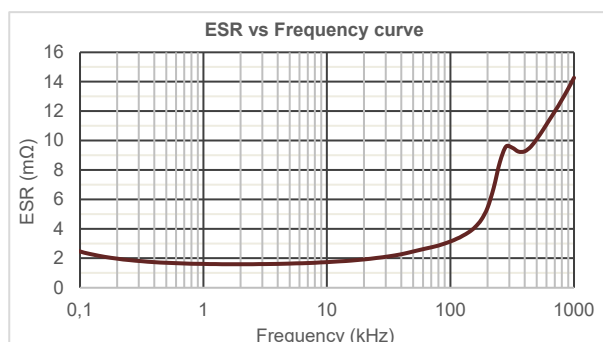

B25697H1986K801

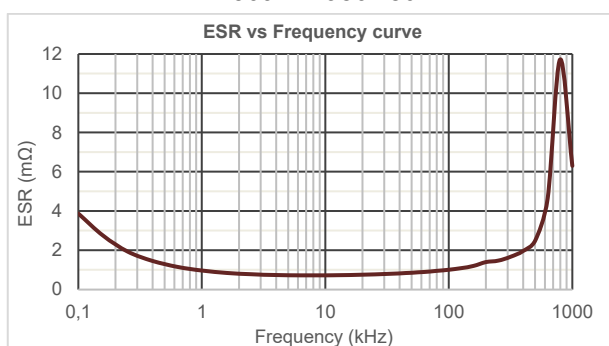

B25697H1157K801

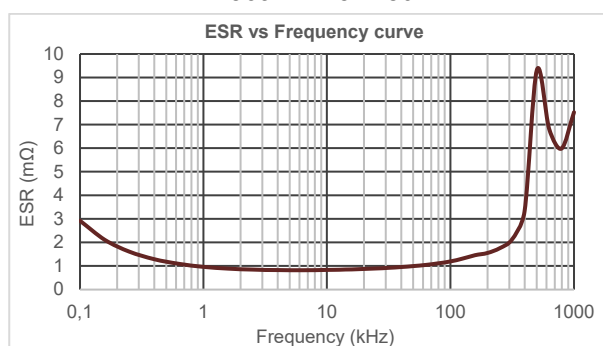

B25697H1187K801

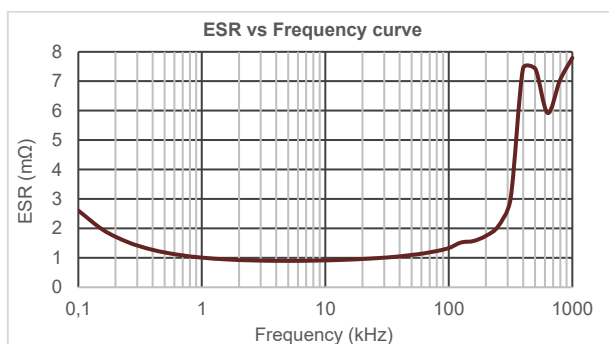

B25697H1207K801

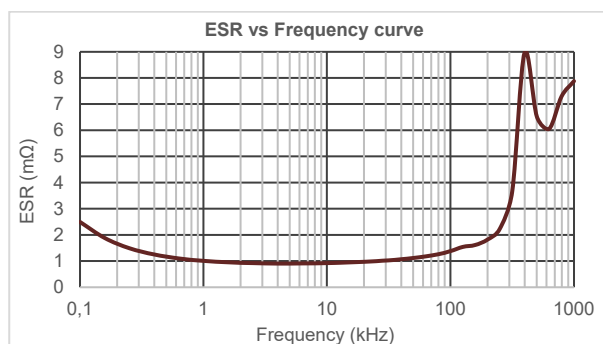

B25697H1247K801

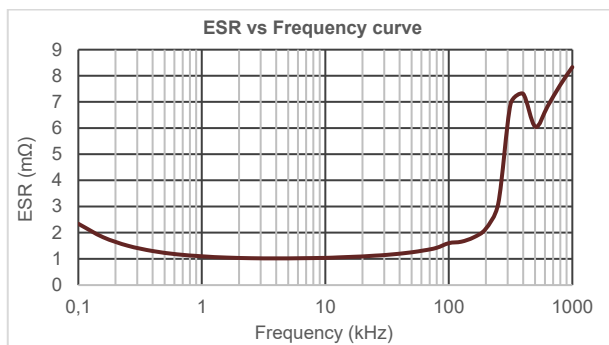

B25697H1297K801

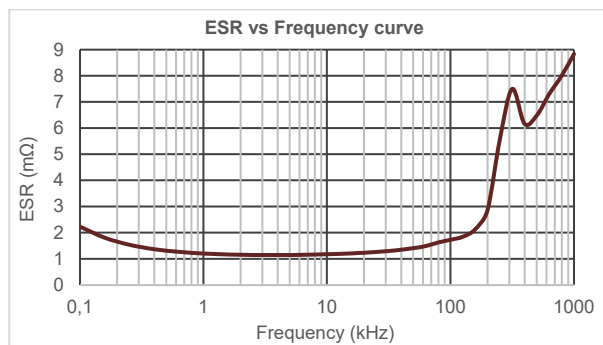

B25697H1327K801

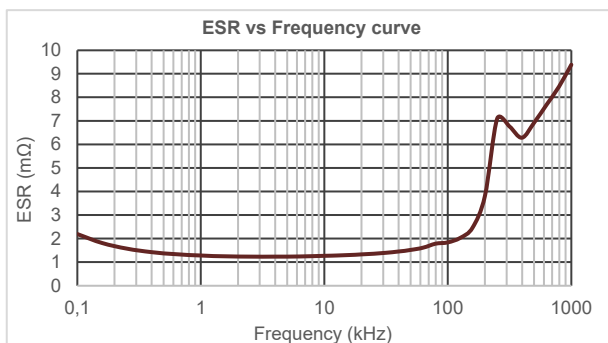

ESR vs Frequency curves for capacitors $V_{R, DC} = 2,000$ VDC

B25696H2476K001

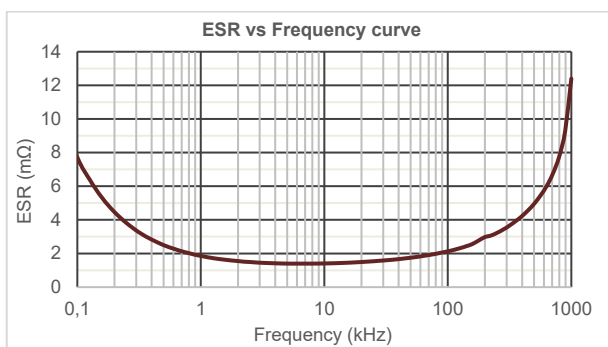

B25696H2716K001

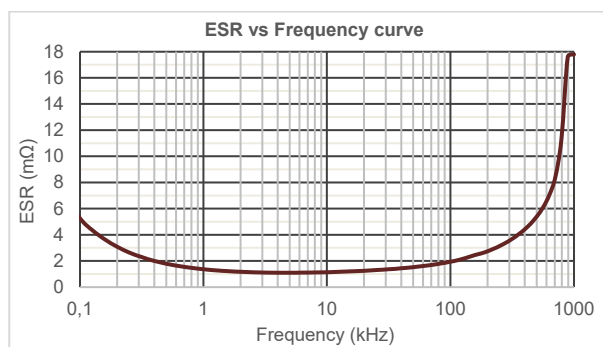

B25696H2746K001

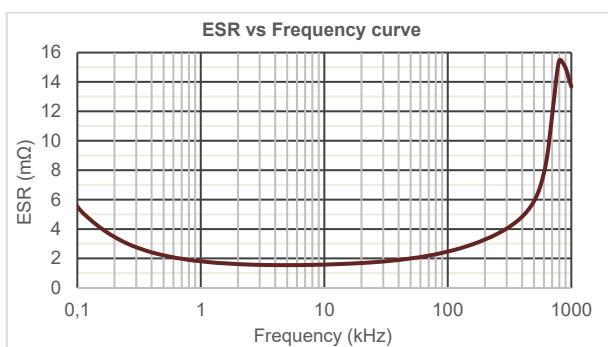

B25696H2107K001

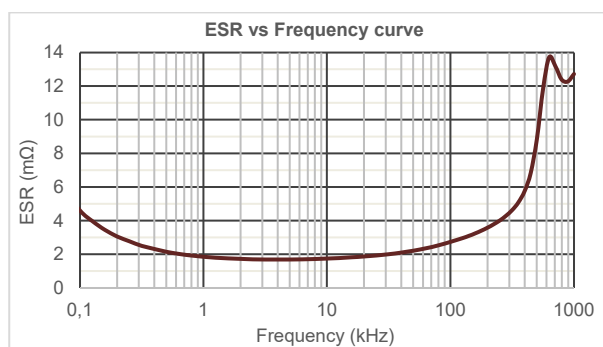

B25696H2117K011

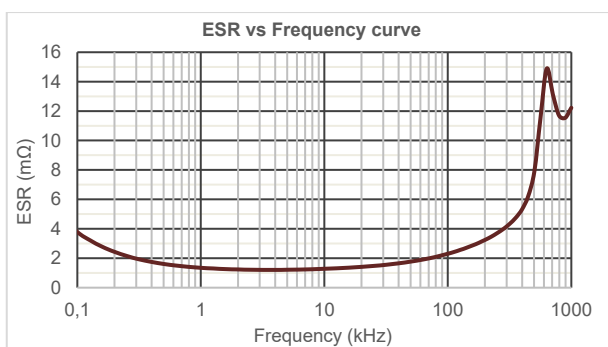

B25696H2117K001

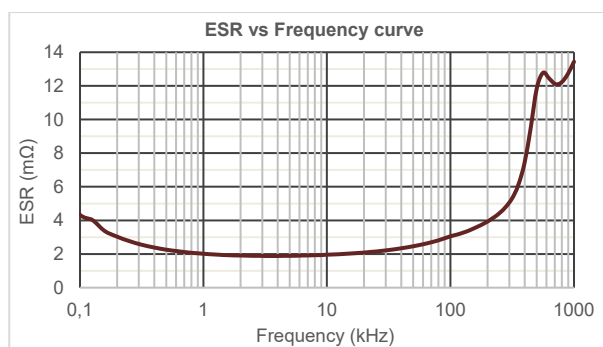

B25696H2157K001

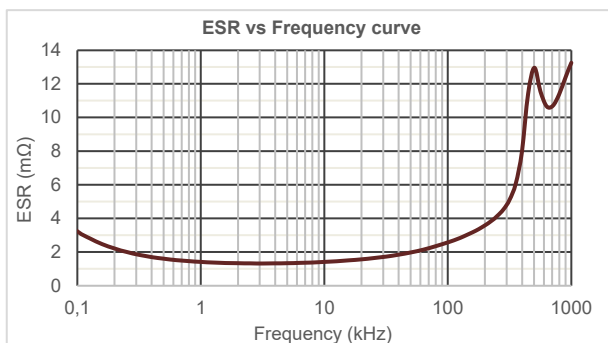

B25696H2167K001

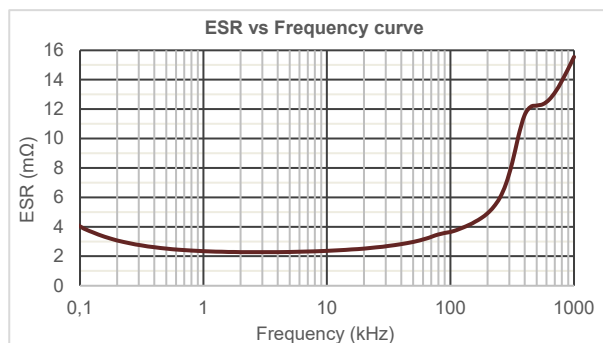

B25696H2187K001

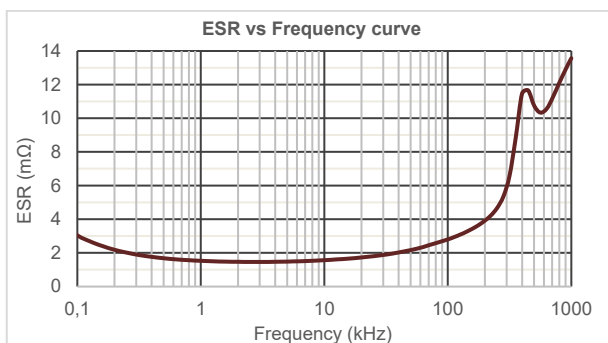

B25696H2247K001

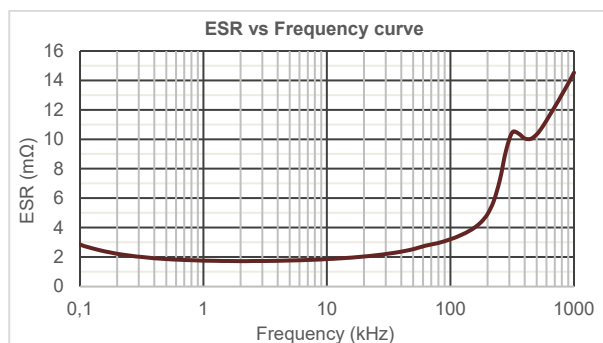

B25697H2776K001

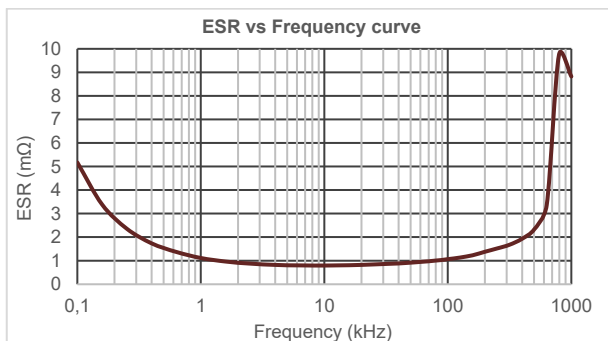

B25697H2127K001

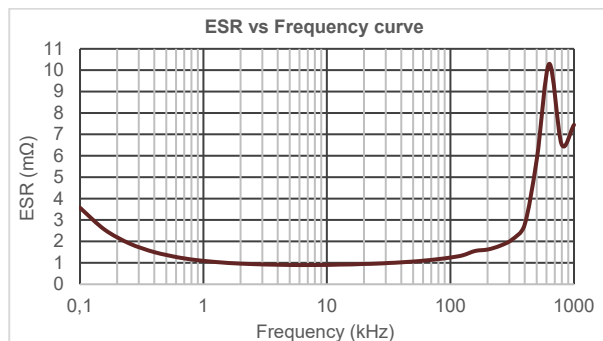

B25697H2157K001

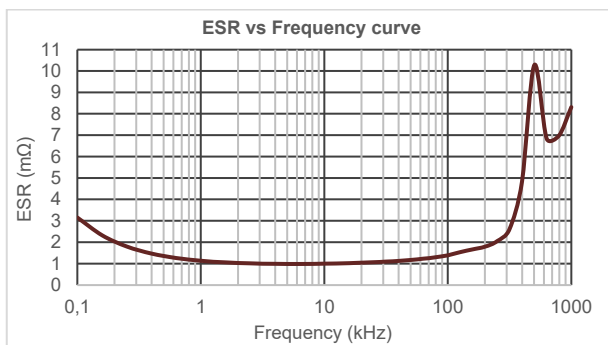

B25697H2167K001

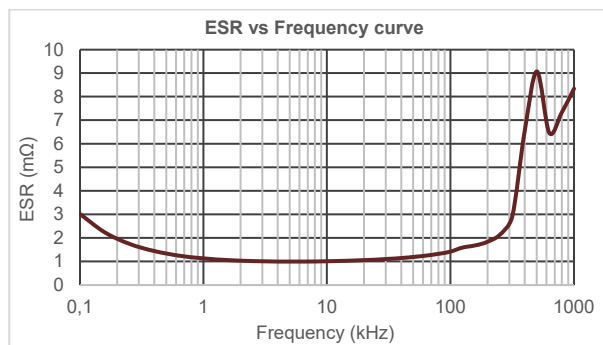

B25697H2197K001

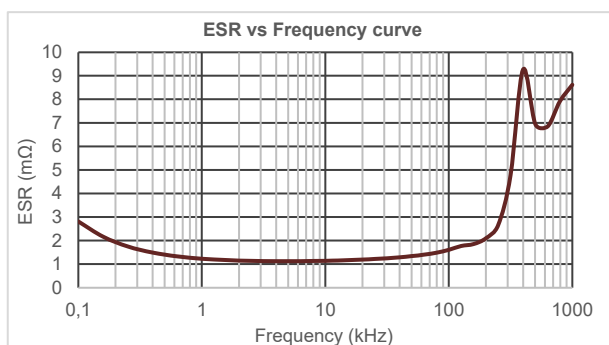

B25697H2237K001

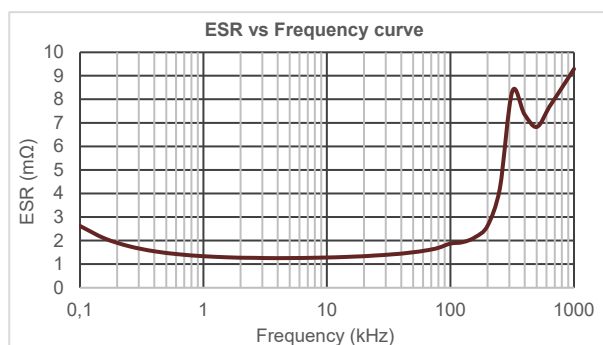

B25697H2257K001

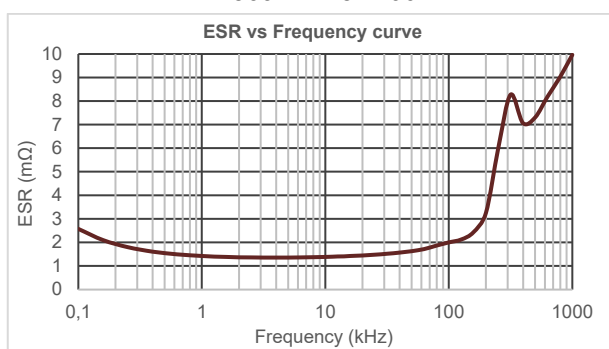

3. Current derating

Current derating curve (for the types with $I_{max, 60^\circ C} < 120A$)

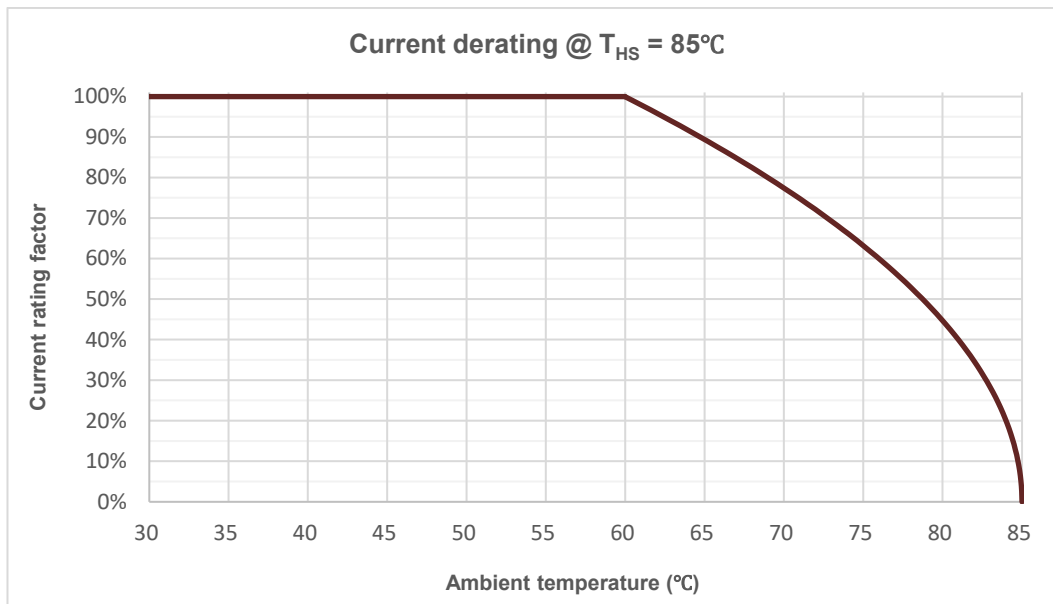

4. Lifetime expectancy

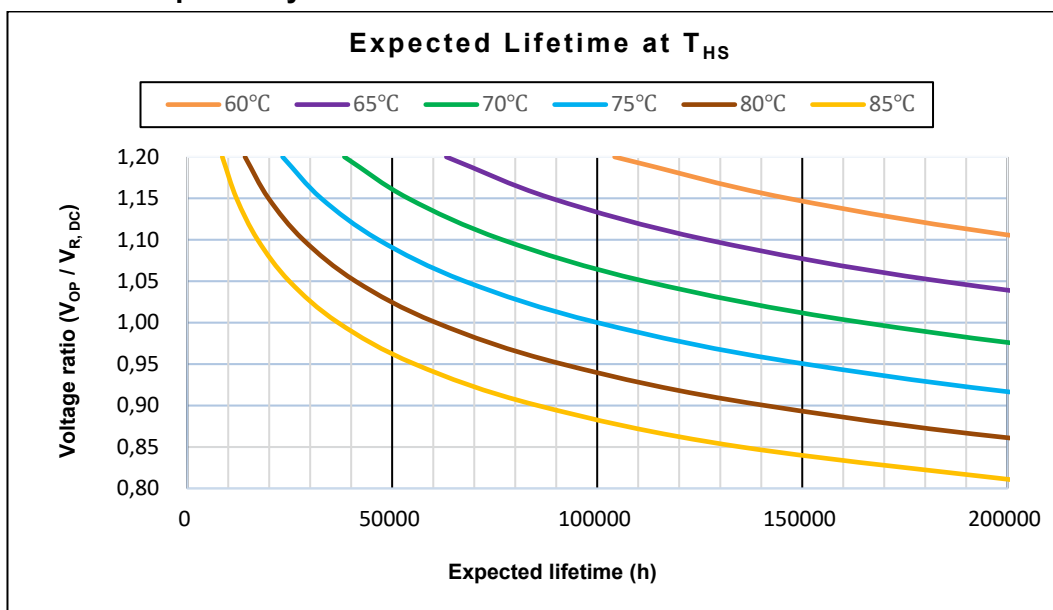

Lifetime expectancy (t_{LD}) in hours at different hotspot temperature (T_{HS}) and voltage $V_{R, DC}$

Failure criteria is capacitance drop higher than 3%.

Lifetime estimations are typical theoretical values derived from lifetime tests based on TDK internal standards or mutually agreed test methods and are intended for guidance purposes only. The useful life does not constitute a warranty of any kind or a prolongation of the agreed warranty period.

5. Expected failure rate

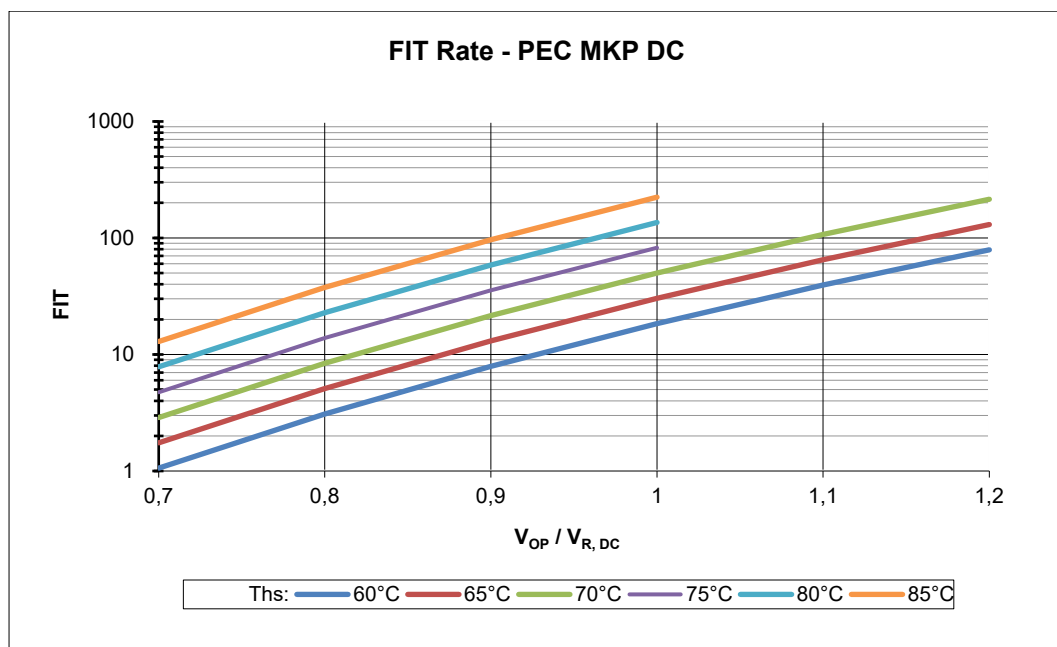

Expected fit rate ($\alpha_{FQ (co)}$) at different hot spot temperatures (T_{HS}) and voltage V_{R, DC}

The FIT (Failure In Time) of a component is defined as the number of expected failures in 10⁹ hours of operation. The FIT rate is calculated based on the number of components operating in the field and the estimated hours of operation. All the reports of failures are taken into consideration for this calculation, which is updated every year.

The other values in the graph are given as indication and calculated based on acceleration factors.

Terms and characteristics

The following definitions apply to power capacitors according to IEC 61071.

Rated capacitance C_R

Nominal value of the capacitance at 20 °C and measuring frequency of 100 Hz.

Rated DC voltage $V_{R, DC}$

Maximum operating peak voltage of either polarity but of a non-reversing type wave form, for which the capacitor has been designed, for continuous operation.

Operating voltage V_{OP}

The operating voltage of the capacitor.

Ripple voltage V_{ripple}

Peak-to-peak alternating component of the unidirectional voltage.

Maximum surge voltage V_s

Peak voltage induced by a switching or any other disturbance of the system which is allowed for a limited number of times and short period.

Insulation voltage V_i

RMS rated value of the insulation voltage of capacitive elements and terminals to case or earth. When it is not specified in the product data sheet, the insulation voltage is at least:

$$V_i = \frac{V_{RDC}}{\sqrt{2}}$$

AC voltage test between terminals and case V_{TC}

Units having all terminals insulated from the container shall be subjected for 10 s to a voltage applied between the terminals (joined together) and the container.

Maximum rate of voltage rise $(dV/dt)_{max}$

Maximum permissible repetitive rate of voltage rise of the operational voltage.

Maximum current I_{max}

Maximum RMS current for continuous operation for the given frequency range and for the maximum ripple voltage. Please provide Frequency Spectrum of RMS current to your sales contact.

Maximum peak current \hat{I}

Maximum permissible repetitive current amplitude during continuous operation.

Maximum peak current (\hat{I}) and maximum rate of voltage rise $(dV/dt)_{max}$ on a capacitor are related as follows:

$$\hat{I} = C \cdot (dV/dt)_{max}$$

Maximum surge current \hat{I}_s

Admissible peak current induced by a switching or any other disturbance of the system which is allowed for a limited number of times and short period.

$$\hat{I}_s = C \cdot (dV/dt)_s$$

Ambient temperature T_A

Temperature of the surrounding air, measured at 10 cm distance and 2/3 of the case height of the capacitor.

Lowest operating temperature $T_{op,min}$

Lowest permitted ambient temperature at which a capacitor may be energized.

Maximum operating temperature $T_{op,max}$

Highest permitted capacitor temperature during operation, i.e. temperature at the hottest point of the case.

Hot-spot temperature T_{HS}

Temperature zone inside of the capacitor at hottest spot.

$$T_{HS} = T_A + I_{RMS}^2 \cdot ESR \cdot R_{th}$$

Tangent of the loss angle of a capacitor $\tan \delta$

Ratio between the equivalent series resistance and the capacitive reactance of a capacitor at a specified sinusoidal alternating voltage, frequency and temperature.

Series resistance R_s

The sum of all Ohmic resistances occurring inside the capacitor.

ESR

Effective resistance which, if connected in series with an ideal capacitor of capacitance value equal to that of the capacitor in question, would have a power loss equal to active power dissipated in that capacitor under specified operating conditions.

$$ESR = \frac{\tan \delta}{\omega \cdot C} = R_s + \frac{\tan \delta_0}{\omega \cdot C}$$

Thermal resistance R_{th}

The thermal resistance indicates by how many degrees the capacitor temperature at the hot spot rises in relation to the dissipation losses.

Maximum power loss P_{max}

Maximum permissible power dissipation for the capacitor's operation.

$$P_{max} = \frac{T_{hs} - T_A}{R_{th}}$$

Self inductance L_{self}

The sum of all inductive elements which are contained in a capacitor.

Resonance frequency f_r

The lowest frequency at which the impedance of the capacitor becomes minimum.

$$f_r = \frac{1}{2\pi \cdot \sqrt{L_{self} \cdot C_R}}$$

Cautions and Warnings

General

- In case of dents of more than 1 mm depth or any other mechanical damage, capacitors must not be used at all.
- Check tightness of the connections/terminals periodically.
- The energy stored in capacitors may be lethal. To prevent any chance of shock, do not handle the capacitor before it is discharged.
- Failure to follow cautions may result, in premature failures, bursting and fire in the worst case.
- Protect the capacitor properly against over current and short circuit.
- TDK Electronics is not responsible for any kind of possible damages to persons or things due to improper installation and application of capacitors for power electronics.

Safety

Electrical or mechanical misapplication of capacitors may be hazardous. Personal injury or property damage may result if the capacitor should burst or from melted material expulsion due to a capacitor's mechanical disruption.

- Ensure good, effective grounding for capacitor metal enclosures.
- Observe appropriate safety precautions during operation (self-recharging phenomena and the high energy contained in capacitors).
- Handle capacitors carefully because they may still be charged even after disconnection.
- The capacitor's terminals, connected bus bars and cables as well as other devices may also be energized.
- Follow good engineering practice.
- When power capacitors are used, suitable measures must always be taken to eliminate possible danger to humans, animals and property both during operation and when a failure occurs. This applies to capacitors both with and without protective devices. Regular inspection and maintenance by a competent person is therefore essential.

Thermal load

After installation of the capacitor it is necessary to verify that maximum hot-spot temperature is not exceeded at extreme service conditions.

Installation

Capacitors must be installed in a cool and well ventilated place, and not close to objects that radiate heat, or in the direct sunlight. Within high-power inverter systems the capacitors usually produce the smallest portion of the total losses, and the permissible operating temperatures are low compared to power semiconductors, reactors and resistors. So, the distance between capacitor and heating sources must be large enough to avoid the capacitor overheating. In case of space constraint to make the best possible use of capacitors, technically and economically, it is advisable to supply forced cooling air.

Mechanical protection

The capacitor has to be installed in a way that mechanical damages and dents in the aluminum case be avoided.

Connecting

Ensure firm fixing of terminals, fixing torque to be applied as per individual specification.

In any case, the maximum specified terminal current may not be exceeded. Please refer to the technical data of the specific series.

Grounding

The threaded bottom stud of the capacitor has to be used for grounding. In case grounding is done via metal chassis that the capacitor is mounted to, the layer of varnish beneath the washer and nut should be removed. In case, capacitor with plastic case, this is not applicable. Ensure the tightening torque does not exceed the limit.

Maintenance recommendation

Disregarding the following measures may result in severe operation failures, bursting and fire:

- Check tightness of the connections/terminals periodically.
- Clean the terminals/bushings periodically to avoid short circuits due dust or other contamination.
- Ensure the current does not exceed the limit.
- In case of a current above the nominal current check your application for modification.
- Check the temperature of energized capacitors. In case of excessive temperature of individual capacitors, it is recommended to replace this capacitor, as this could be an indication for loss factor increase, which is a sign for reaching end of life.

Storage and operating conditions

Do not use or store capacitors in corrosive atmosphere, especially where chloride gas, sulfide gas, acid, alkali, salt or the like are present. In dusty environments regular maintenance and cleaning especially of the terminals is required to avoid conductive path between phases and/or phases and ground.

- Capacitors should not be stored in high temperatures and/or high humidity for long time, we recommend the following storage conditions:
 - temperature between $-40^{\circ}\text{C} \sim 40^{\circ}\text{C}$
 - humidity $\leq 80\%$ RH as average per year
- Storage should not exceed 2 years (from datecode printed on the capacitor). After 1 year of storage time, capacitors must be checked electrically.

Lifetime expectancy

As a rule, TDK Electronics is unfamiliar with individual customer applications or less familiar with them than the customers themselves. The results will not contain the various influences which might occur in respect to TDK products, when TDK products will be incorporated into the customer application. For these reasons, it is ultimately incumbent on the customer to check and decide whether a TDK product with the properties described in the product specification is suitable for use in a particular customer application.

We also point out that in individual cases a malfunction of electronic components or failure before the end of their usual service life cannot be completely ruled out in the current state of the art, even if they are operated as specified. In customer applications requiring a very high level of operational safety and especially in customer applications in which the malfunction or failure of an electronic component could endanger human life or health (e.g. in accident prevention or life-saving systems), it must

therefore be ensured by means of suitable design of the customer application or other action taken by the customer (e.g. installation of protective circuitry or redundancy) that no injury or damage is sustained by third parties in the event of malfunction or failure of an electronic component.

Handling

Do not handle the capacitor before it is discharged! When handling the capacitor, do not take the capacitor from the terminal. This can cause accidents in case the capacitor is charged and additionally the terminal could break.

Important notes

The following applies to all products named in this publication:

1. Some parts of this publication contain **statements about the suitability of our products for certain areas of application**. These statements are based on our knowledge of typical requirements that are often placed on our products in the areas of application concerned. We nevertheless expressly point out **that such statements cannot be regarded as binding statements about the suitability of our products for a particular customer application**. As a rule we are either unfamiliar with individual customer applications or less familiar with them than the customers themselves. For these reasons, it is always ultimately incumbent on the customer to check and decide whether a product with the properties described in the product specification is suitable for use in a particular customer application.
2. We also point out that **in individual cases, a malfunction of electronic components or failure before the end of their usual service life cannot be completely ruled out in the current state of the art, even if they are operated as specified**. In customer applications requiring a very high level of operational safety and especially in customer applications in which the malfunction or failure of an electronic component could endanger human life or health (e.g. in accident prevention or life-saving systems), it must therefore be ensured by means of suitable design of the customer application or other action taken by the customer (e.g. installation of protective circuitry or redundancy) that no injury or damage is sustained by third parties in the event of malfunction or failure of an electronic component.
3. **The warnings, cautions and product-specific notes must be observed.**
4. In order to satisfy certain technical requirements, **some of the products described in this publication may contain substances subject to restrictions in certain jurisdictions (e.g. because they are classed as hazardous)**. Useful information on this will be found in our Material Data Sheets on the Internet (www.tdk-electronics.tdk.com/material). Should you have any more detailed questions, please contact our sales offices.
5. We constantly strive to improve our products. Consequently, **the products described in this publication may change from time to time**. The same is true of the corresponding product specifications. Please check therefore to what extent product descriptions and specifications contained in this publication are still applicable before or when you place an order.

We also **reserve the right to discontinue production and delivery of products**. Consequently, we cannot guarantee that all products named in this publication will always be available. The aforementioned does not apply in the case of individual agreements deviating from the foregoing for customer-specific products.

6. Unless otherwise agreed in individual contracts, **all orders are subject to our General Terms and Conditions of Supply**.
7. **Our manufacturing sites serving the automotive business apply the IATF 16949 standard**. The IATF certifications confirm our compliance with requirements regarding the quality management system in the automotive industry. Referring to customer requirements and customer specific requirements ("CSR") TDK always has and will continue to have the policy of respecting individual agreements. Even if IATF 16949 may appear to support the acceptance of unilateral requirements, we hereby like to emphasize that **only requirements mutually agreed upon can and will be implemented in our Quality Management System**. For clarification purposes we like to point out that obligations from IATF 16949 shall only become legally binding if individually agreed upon.

Important notes

8. The trade names EPCOS, CarXield, CeraCharge, CeraDiode, CeraLink, CeraPad, CeraPlas, CSMP, CTVS, DeltaCap, DigiSiMic, FilterCap, FormFit, InsuGate, LeaXield, MediPlas, MiniBlue, MiniCell, MKD, MKK, ModCap, MotorCap, PCC, PhaseCap, PhaseCube, PhaseMod, PhiCap, PiezoBrush, PlasmaBrush, PowerHap, PQSine, PQvar, SIFERRIT, SIFI, SIKOREL, SilverCap, SIMDAD, SiMic, SIMID, SineFormer, SIOV, SurfIND, ThermoFuse, WindCap, XieldCap are **trademarks registered or pending** in Europe and in other countries. Further information will be found on the Internet at www.tdk-electronics.tdk.com/trademarks.

Release 2024-02