

CONNECTORS USED:

PART DESCRIPTION	PART NAME	HOUSING	QTY	CONTACT	QTY	CRIMPING TOOL	MANUFACT.
CN1 (INPUT TERMINAL)	B3P5-VH(LF)(SN)	VHR-5N	1	SVH-21T-P1.1	3	YC-160R, YC161R, YC164R	J.S.T
CN51(OUTPUT TERMINAL)	B6P-VH(LF)(SN)	VHR-6N	1	SVH-41T-P1.1	6	YC-930R	J.S.T

(HOUSINGS, PINS & TOOL ARE NOT INCLUDED WITH THE PRODUCT.)

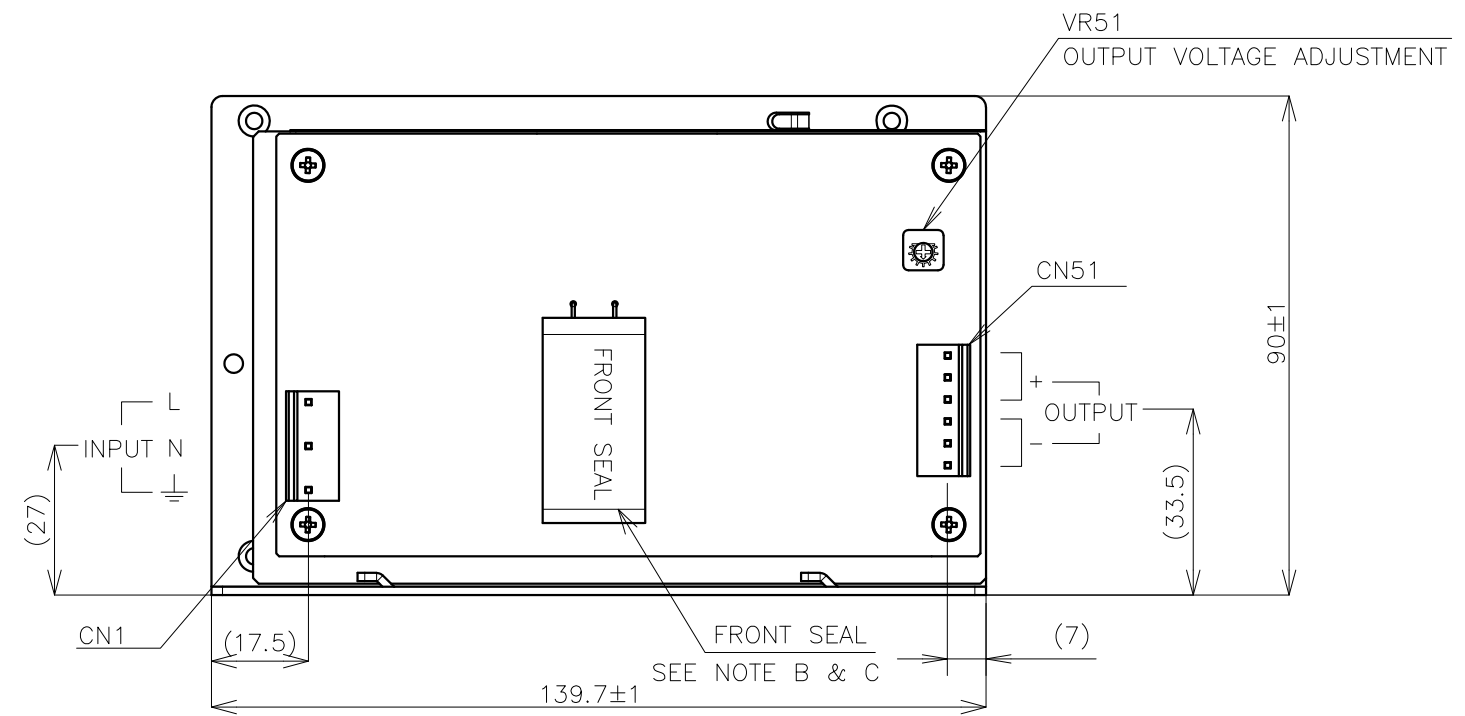
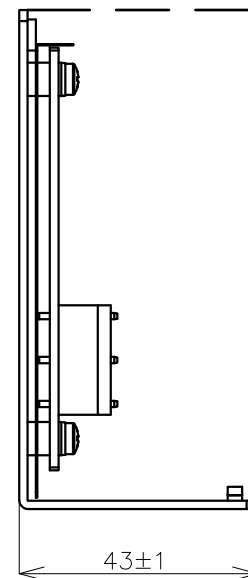
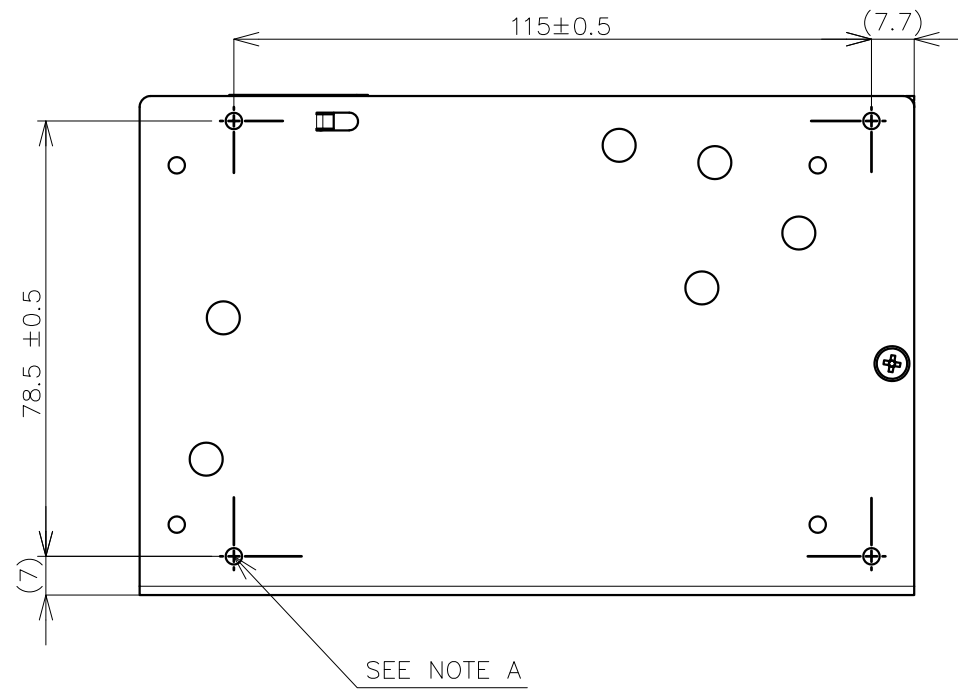
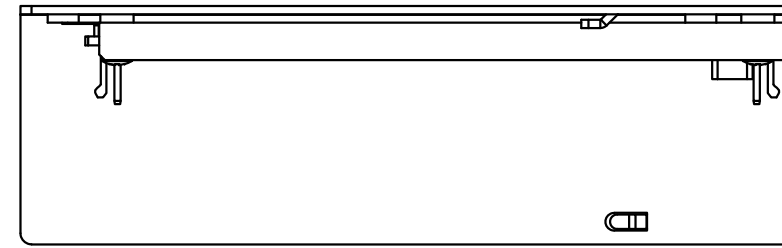

NOTE:

A: 4-M3 TAPPED HOES ARE FOR CUSTOMER'S CHASSIS MOUNTING HOLES. ALL MUST BE SCREWED IN ORDER TO CONFORM THE VIBRATION AND EMI SPEC.

(SCREW PENETRATION DEPTH 4mm MAX.)

B: MODEL NAME, INPUT VOLTAGE RANGE, NOMINAL OUTPUT VOLTAGE, MAXIMUM OUTPUT CURRENT AND SAFETY MARKING (FOR ONLY APPROVED PRODUCTS) ARE SHOWN HERE IN ACCORDANCE WITH THE SPECIFICATIONS.

C: COUNTRY OF MANUFACTURE WILL BE SHOWN HERE.

D: \perp IS FOR SAFETY GROUND CONNECTION.

(unit : mm)

MODEL NAME	CUS150M1/L
TDK-Lambda	

CA848-02-01/L-B