

1500W to 1800W, 85-305 Vac, 50/60/400 Hz Input AC-DC Power Modules

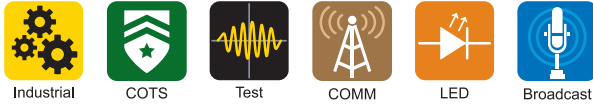

The PFE1500FB and PFE1800FB series of AC-DC power modules are designed for applications where convection or forced air cooling is not feasible. These modules are particularly well-suited for use in sealed box outdoor enclosures or liquid-cooled setups. When it comes to performance, these PCB-mounted power modules accept an extended wide range AC input and deliver an adjustable, regulated output. Notably, these modules provide high usable power at elevated ambient temperatures, thanks to their conduction-cooled metal case, which is rated from -40°C to 100°C. Additionally, these third-generation modules feature a PMBus™ interface with read/write capability, enabling remote monitoring and programming. Overall, the PFE1500FB and PFE1800FB series combines efficiency, versatility, and robustness for demanding environments.

Features	Benefits
• Compact 6.19" x 3.54" x 0.6" Brick Package	• Less Board Area Required
• 5-Sided Metal Case	• Easier Thermal Management and Lower Radiated EMI
• High Power Density, High Efficiency	• Less Waste Heat to Manage and Reduced AC Power Consumption
• -40 to 100°C Rated Operating Baseplate Temperature	• Cold plate / Conduction Cooling for Fanless and Rugged Environments
• PMBus™ Communications and Control	• Remote Monitoring and Programming through PMBus
• Programmable Droop Function for Load Sharing	• Simplified Paralleling for Higher Power or Redundant Applications
• 50/60 and 400Hz (MIL-STD-704F) Line Frequency	• Single Part Covers Multiple Line Frequencies / Applications
• Programmable Output Current Limit, Output Undervoltage and Overvoltage	• Greater System Design Flexibility, Reducing the Need for External Added Circuits

Model Selector									
Model	Input Voltage Range (Vac)	Nominal Input Line Frequency (Hz) ⁽³⁾	Nominal Output Voltage (Vdc)	Output Adjust Range (Vdc)	Maximum Output Current (A)	Maximum Power (W) ⁽⁴⁾	Typical Efficiency (%)	Mounting Inserts	Pin Length (mm/in)
PFE1500FB-28-000-R	85 - 305	50 / 60 / 400	28	22.4 - 36.4	53.6	1500	91	3.3mm Ø Non-Threaded	6.6 / 0.26
PFE1500FB-28-100-R	85 - 305	50 / 60 / 400	28	22.4 - 36.4	53.6	1500	91	3mm (M3) Threaded	6.6 / 0.26
PFE1500FB-48-000-R	85 - 305	50 / 60 / 400	48	38.4 - 57.6	31.25	1500	92	3.3mm Ø Non-threaded	6.6 / 0.26
PFE1500FB-48-100-R	85 - 305	50 / 60 / 400	48	38.4 - 57.6	31.25	1500	92	3mm (M3) Threaded	6.6 / 0.26
PFE1800FB-48-000-R	85 - 305	50 / 60 / 400	48	38.4 - 57.6	37.5	1800	92	3.3mm Ø Non-threaded	6.6 / 0.26
PFE1800FB-48-100-R	85 - 305	50 / 60 / 400	48	38.4 - 57.6	37.5	1800	92	3mm (M3) Threaded	6.6 / 0.26
PFE1800FB-60-000-R	85 - 305	50 / 60 / 400	60	48.0 - 63.0	30	1800	93	3.3mm Ø Non-threaded	6.6 / 0.26
PFE1800FB-60-100-R	85 - 305	50 / 60 / 400	60	48.0 - 63.0	30	1800	93	3mm (M3) Threaded	6.6 / 0.26

Consult Technical Support For Availability.

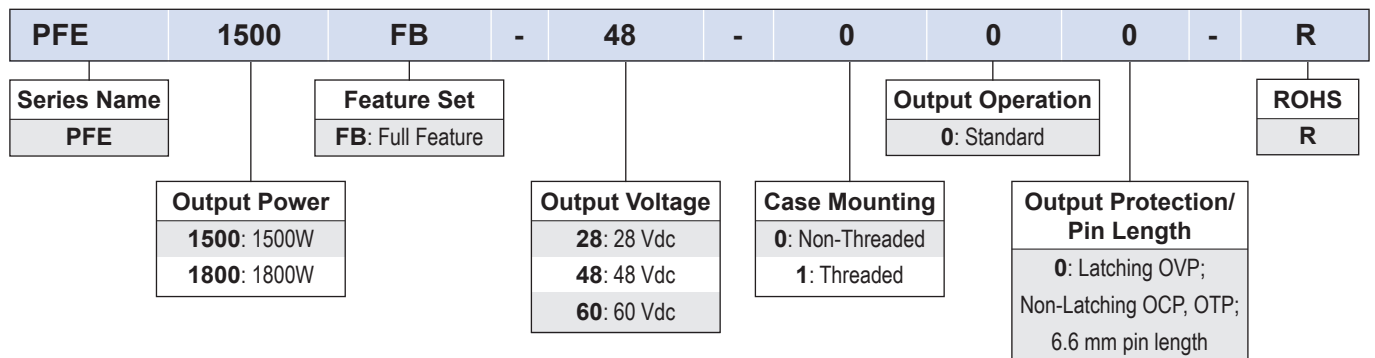

Related Products		
Type	Part Number	Description
AC-DC Power Module	PFE1000FA	85-265Vac, 1000W, -40 to 100°C case, 160x100x13.4 mm brick format
AC-DC Power Module	PFE500SA	85-265Vac, 500W, -40 to 100°C case, 116.8x61x12.7 mm brick format
ORing FET Module	i1R	60V/60A or 30V/80A ORing FET (Ideal Diode) Modules
Evaluation Kit	PFE15W48-100-EVK-S2	EV-Kit for PFE1500FB-48-100-R module with FPFH2V015A-001 input filter module
Evaluation Kit	PFE18W48-100-EVK-S2	EV-Kit for PFE1800FB-48-100-R module with FPFH2V015A-001 input filter module
Evaluation Kit	PFE18W60-100-EVK-S2	EV-Kit for PFE1800FB-60-100-R module with FPFH2V015A-001 input filter module

Specifications					
Model		PFE1500FB-28	PFE1500FB-48	PFE1800FB-48	PFE1800FB-60
Input					
Input Voltage Range	Vac	85 - 305			
Input Frequency (Single Phase)	Hz	47 - 63 (Including 60Hz Transients per MIL-HDBK-704-6) 375 - 425 (85 - 140 Vac Input) / 360 - 800 Hz Transient per MIL-HDBK-704-4, SVF110 ⁽⁵⁾			
Input Current (115/230/277 Vac)	A	14 / 8 / 7.5		15 / 9 / 8	
Inrush Current	A	Refer to Instruction Manual and Evaluation Data			
Leakage Current (115 Vac)	mA	0.5 typical (Refer to Instruction Manual for recommended external components and test measurement setup)			
Power Factor (>80% Load)	-	> 0.96			
Harmonic Compliance	-	Meets IEC61000-3-2, Class A			
No Load Power Consumption (115V, 60Hz)	W	5 (Enable ON); 2 (Enable OFF)			7(Enable ON);2(Enable OFF)
Input Undervoltage Protection	Vac	80 (typical), Shutdown - autorecovery			
Hold-up Time	ms	External bulk capacitance dependent. Refer to Instruction Manual and Evaluation Data.			
Efficiency (typ 115/230/277Vac, 100% Load)	%	89.3 / 91.2 / 90.5	90 / 92 / 91.5	90 / 92 / 91.5	91 / 93 / 92
Conducted & Radiated EMI	-	EN55032 Class A with external filter (Refer to Instruction Manual)			
Immunity	-	IEC 61000-4-x (refer to Immunity Data).			
Insulation Class	-	Class II			
Safety Certifications and Markings	-	IEC/EN/UL/CSA 62368-1, CE Mark and UKCA Mark ⁽⁵⁾			
Output					
Output Voltage Setpoint Tolerance	%	±1			
Line Regulation	%	0.20			
Load Regulation ⁽⁶⁾	%	0.20			
Total Regulation ⁽⁶⁾	%	4%			
Output Current (115/230/277 Vac)	A	44.6 / 53.6 / 53.6	26 / 31.25 / 31.25	31.25 / 37.5 / 37.5	25 / 30 / 30
Max Output Power (115/230/277 Vac) ⁽⁴⁾	W	1250/1500 /1500	1250/1500 /1500	1500/1800 /1800	1500/1800 /1800
Output Voltage Adjustment		External Resistor or through PMBus. See Model Table for Output Adjustment Range.			
Ripple & Noise (100% Load)	mV	500	400	400	800
		Refer to Instruction Manual for Test Setup.			
Minimum Load	-	No minimum load required.			
Overcurrent Protection	A	~110% I _{o,max} , delayed Hiccup/Autorecovery, user programmable through PMBus (Refer to Instruction Manual for full capability). Constant Current Voltage Foldback: 10%-100% I _{o,max} (User enabled and programmable via PMBus)			
Short Circuit Protection (Hiccup)	A	103	63	75	63
Overvoltage Protection (max)	V	130% V _{o,nom} (Default), Latching 80% - 130% V _{o,nom} . User adjustable via PMBus, refer to Instruction Manual			
Overtemperature Protection	°C	Autorecovery, 20°C internal hysteresis (refer to Instruction Manual for full capability)			
Output Undervoltage Protection	V	30% V _{o,nom} Default, Autorecovery 30%~100% V _{o,nom} - User adjustable via PMBus, refer to Instruction Manual			
Remote Sense	-	3% V _{o,nom} via RS(+) pin			
Remote ON/OFF	-	Negative Logic; Low (< 1.4V) = Module On (300 µA, 3.6V max)			
Power Good	-	Active Low (≤ 1 Vdc, Open-Drain, 150 mA max sink current, 50 V max voltage)			
Auxiliary Output	Vdc	9.5 - 14 @ 200 mA max (referenced to SGND)			
External Load Capacitance	µF	680 - 10,000			
Series Operation	-	Yes			
Parallel Operation	-	Yes, Droop Mode enabled with 0 mV/A. Refer to Instruction Manual to set proper droop rate for parallel.			
Droop Rate	mV/A	0 - 200 (User adjustable through PMBus. Refer to Instruction Manual)			
Switching Frequency (PFC / DC-DC)	kHz	200 / 200 (fixed)			

Specifications		PFE1500FB-28	PFE1500FB-48	PFE1800FB-48	PFE1800FB-60
Environmental					
Operating Baseplate Temperature	°C	-40 to 100 (see derating curves)			
Storage Temperature	°C	-55 to 125			
Humidity (non condensing)	%RH	20-95 (Operating) / 10-95 (Non Operating)			
Cooling	-	Conduction			
Altitude	m	3,000			
Withstand Voltage	Vac	Input to Output: 3.0kVac; Input to Case: 2.5kVac; Output to Case: 1.5kVdc			
Vibration	-	MIL-STD-810G 514.6 Procedure I, Cat 4			
Shock	-	MIL-STD-810G 516.6 Procedure I			
Other					
Communications Interface	-	i ² C (2 Address pins, CLK, Data, Alert) / PMBus Protocol (refer to PFE PMBus Manual and GUI)			
Weight (max)	g	540			
Size (LxWxH)	mm	157.2 x 89.9 x 15.2			
Size (LxWxH)	in	6.19 x 3.54 x 0.60			
MTBF - Telcordia SR332, Issue 4	Hrs	2M, 40 °C, 100% Load			
Warranty	yrs	3			

Notes

- (1) See website for detailed documentation and design tools: [Instruction Manual](#), Evaluation Data, Immunity Data, [PMBus Manual](#), PMBus GUI.
- (2) Specifications are typical based on nominal inputs, 50/60Hz operation, 25°C ambient temperature unless otherwise stated.
- (3) External components are required for operation as detailed in the Instruction Manual.
- (4) Total output power including the auxiliary output at highline input, refer to Output Derating curves provided.
- (5) PFE-FB series is designed and qualified to operate at 50/60/400Hz input line frequency. 400Hz is not included in the safety certification.
- (6) Excluding droop mode operation.

PFE-FB Series - Basic Connection Diagram

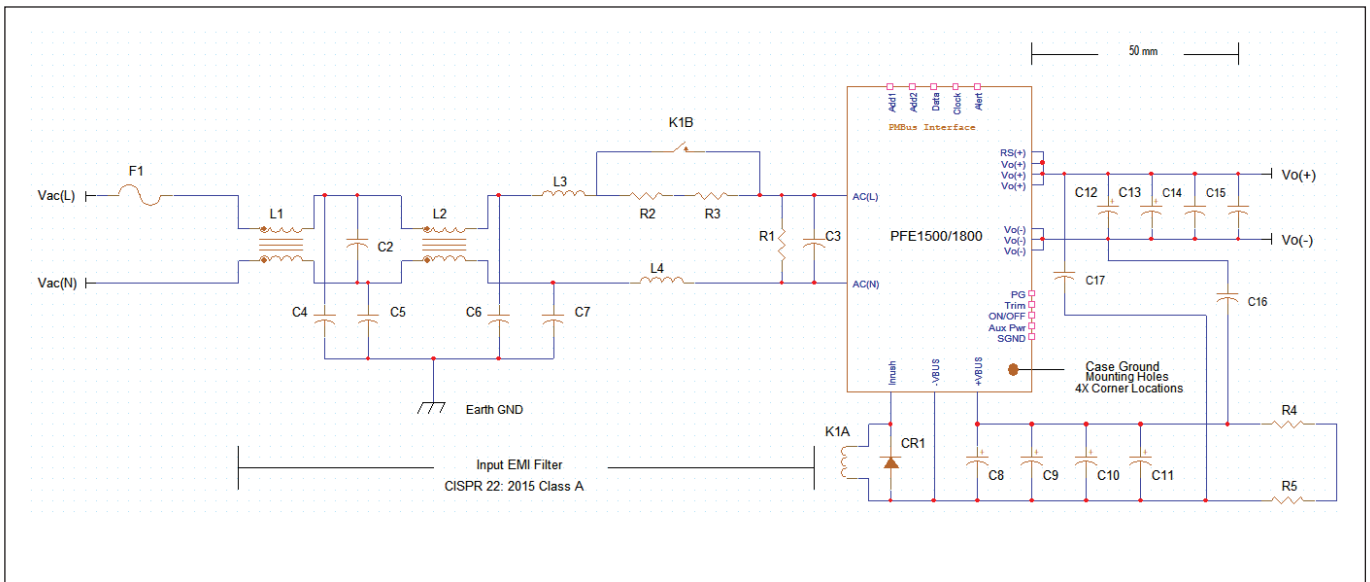

Derating Curves

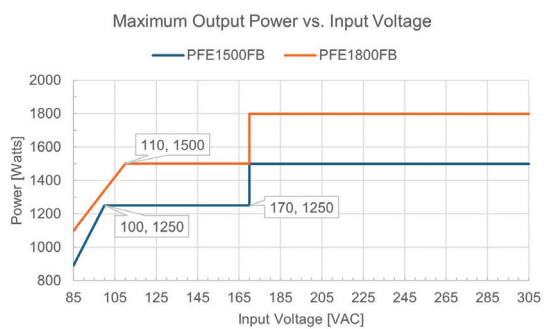
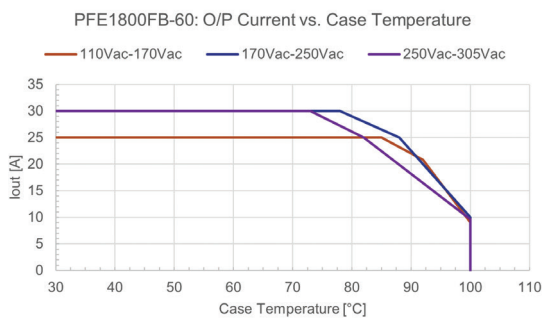
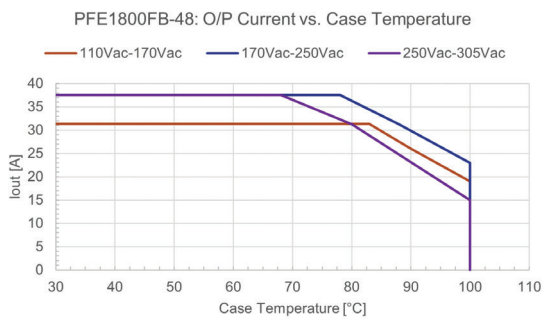
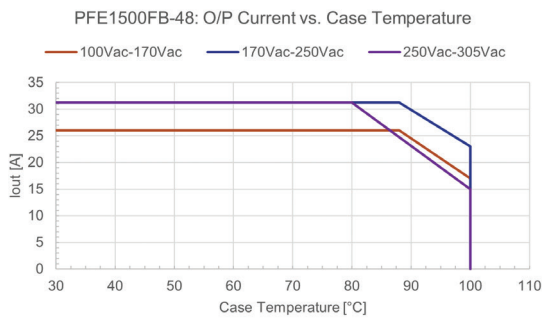
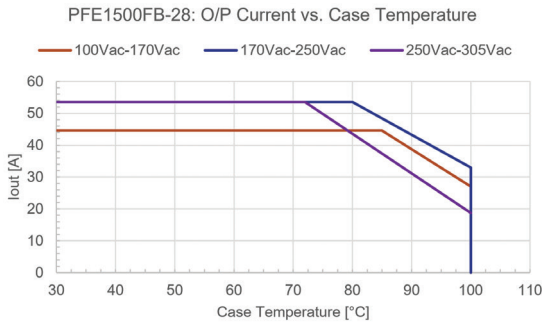

Typical Efficiency Curves

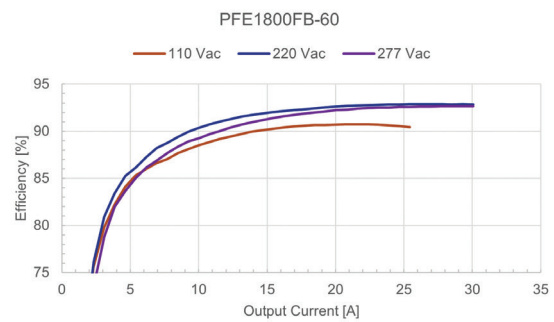
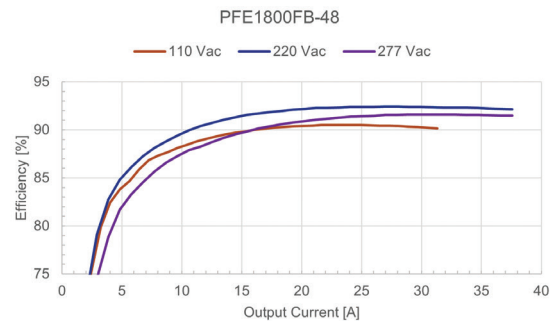
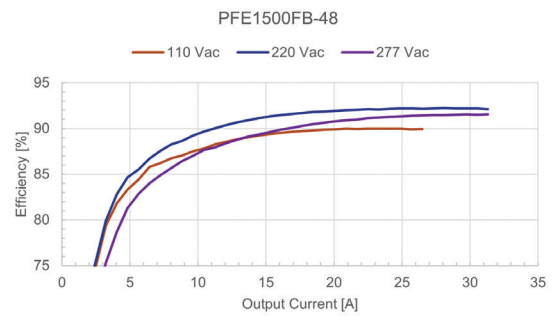
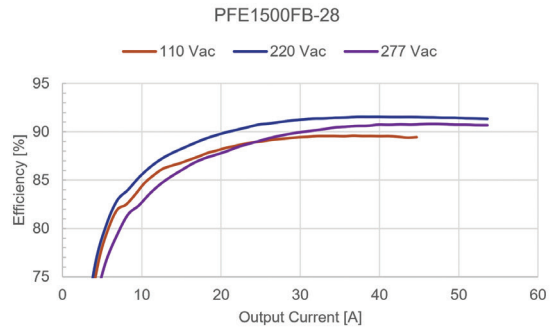

Pin Assignment



PIN #	PIN DESIGNATION	PIN #	PIN DESIGNATION
1	AC(L)	13	PMBUS Address 2
2	AC (N)	14	PMBUS Address 1
3	Vout(-)	15	Trim
4	Vout(-)	16	On/Off
5	Vout(-)	17	SGND
6	RS(+)	18	PGood
7	Vout(+)	19	Aux Pwr
8	Vout(+)	20	Inrush Control
9	Vout(+)	21	Reserved
10	PMBus Clock	22	Reserved
11	PMBus Data	23	-VBUS
12	PMBus Alert	24	+VBUS

Note:

- a) Module case can be connected to Earth Ground through the mounting holes.
- b) +VBUS and -VBUS terminals are primary voltage with high voltage rating (460 Vdc).
- c) Do not connect any external load(s) across +VBUS and -VBUS terminals. Otherwise, it may damage the module.
- d) Pins 20 through 23 have a high voltage differential relative to AC input (L, N, PE) and +VBUS (Pin 24). Please observe proper creepage and clearance based on intended conditions of use and applicable safety standards.

Mechanical Drawing

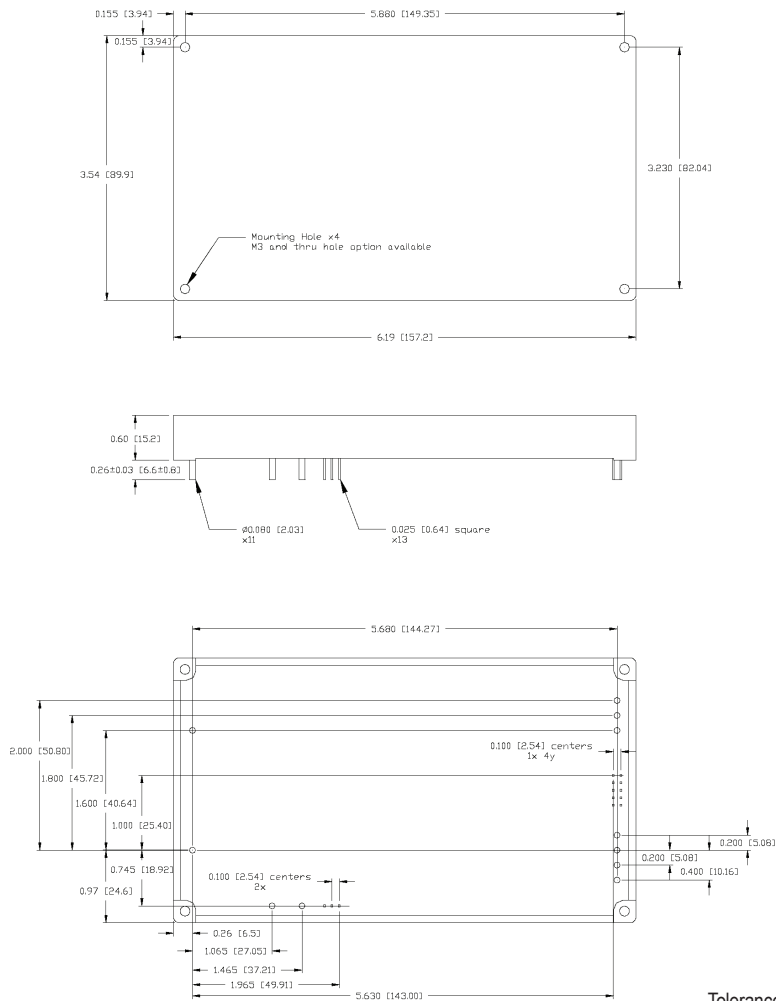

Dimensions in inches [mm]
Tolerance: x.xx ± 0.02 [0.5]; x.xxx ± 0.010 [0.25]



TDK-Lambda France SAS

Tel: +33 1 60 12 71 65
 ttf.fr-powersolutions@tdk.com
 www.emea.lambda.tdk.com/fr



TDK-Lambda Americas

Tel: +1 800-LAMBDA-4 or 1-800-526-2324
 tia.powersolutions@tdk.com
 www.us.lambda.tdk.com



Italy Sales Office

Tel: +39 02 61 29 38 63
 ttf.it-powersolutions@tdk.com
 www.emea.lambda.tdk.com/it



TDK Electronics do Brasil Ltda

Tel: +55 11 3289-9599
 sales.br@tdk-electronics.tdk.com
 www.tdk-electronics.tdk.com/en



Netherlands

tfn.nl-powersolutions@tdk.com
 www.emea.lambda.tdk.com/nl



TDK-Lambda Corporation

Tel: +81-3-6778-1113
 www.jp.lambda.tdk.com



TDK-Lambda Europe GmbH

Tel: +49 7841 666 0
 tlg.powersolutions@tdk.com
 www.emea.lambda.tdk.com/de



TDK-Lambda (China) Electronics Co. Ltd.

Tel: +86 21 6485-0777
 tlc.powersolutions@tdk.com
 www.lambda.tdk.com.cn



Austria Sales Office

Tel: +43 2256 655 84
 tlg.at-powersolutions@tdk.com
 www.emea.lambda.tdk.com/at



TDK-Lambda Singapore Pte Ltd.

Tel: +65 6251 7211
 tis.marketing@tdk.com
 www.sg.lambda.tdk.com



Switzerland Sales Office

Tel: +41 44 850 53 53
 tlg.ch-powersolutions@tdk.com
 www.emea.lambda.tdk.com/ch



TDK India Private Limited, Power Supply Division

Tel: +91 80 4039-0660
 mathew.philip@tdk.com
 www.sg.lambda.tdk.com



TDK-Lambda Europe GmbH

Tel: Tel. +45 3222 8086
 tlg.dk-powersolutions@tdk.com
 www.emea.lambda.tdk.com/dk



TDK-Lambda UK Ltd.

Tel: +44 (0) 12 71 85 66 66
 tlu.powersolutions@tdk.com
 www.emea.lambda.tdk.com/uk



TDK-Lambda Ltd.

Tel: +9 723 902 4333
 tii.powersolutions@tdk.com
 www.emea.lambda.tdk.com/il-en

For Additional Information, please visit
<https://product.tdk.com/en/power/>

