

HWS3000G series

Communication manual

1 Table of contents

1	Table of contents	1
2	Overview	4
3	Communication system wiring and connections.....	5
3.1	HWS3000x series communication terminal.....	5
3.2	Connection with client	5
4	HWS3000x setup	7
4.1	Server address and serial communication settings.....	7
4.2	Power supply.....	7
4.3	Setting unique server addresses	8
4.4	If you forget the serial communication settings	8
5	Communication specifications.....	9
5.1	Transmission specifications	9
5.2	Communication protocol.....	11
5.2.1	Protocol overview	11
5.2.2	Protocol details.....	12
5.2.3	Non-supported specifications.....	12
5.3	Message frame configuration.....	14
5.3.1	Request frame	14
5.3.2	Response frame	15
5.3.3	Exception response frame	16
5.4	HWS3000x support function code.....	17
5.4.1	FC : 4 (0x04) Read Input Registers.....	17
5.4.2	FC : 3 (0x03) Read Holding Registers.....	18
5.4.3	FC : 6 (0x06) Write Single Register.....	19
5.4.4	FC : 16 (0x10) Write Multiple registers.....	20
5.4.5	FC : 23 (0x17) Read/Write Multiple registers.....	22
5.5	HWS3000x Support diagnostic function	24
5.5.1	SC : 1 (0x0001) / Restart Communications Option	25
5.5.2	SC : 4 (0x0004) / Force Listen Only Mode.....	25
6	Register list	26
6.1	Input Registers	26

6.2	Holding Registers.....	28
7	Register details.....	31
7.1	Input Registers	31
7.1.1	Status.....	31
7.1.2	Warning.....	33
7.1.3	Output voltage.....	34
7.1.4	Output current	35
7.1.5	Ambient temperature.....	36
7.1.6	Cumulative power output time.....	37
7.1.7	Cumulative power supply time	37
7.1.8	CV target confirmation	38
7.1.9	CC target confirmation.....	39
7.1.10	AUX output voltage	40
7.1.11	DelayOCP integrated value.....	40
7.1.12	Model name	41
7.1.13	Serial No.	42
7.1.14	Lot No.	42
7.1.15	Rated output voltage value.....	43
7.1.16	Maximum output current value.....	44
7.1.17	Maximum output power value	45
7.1.18	Minor alarm log read.....	46
7.1.19	Major alarm log read.....	47
7.1.20	Firmware version	47
7.2	Holding Registers.....	48
7.2.1	Remote control ON	48
7.2.2	Remote control source selection	48
7.2.3	Communication CNT storage	49
7.2.4	Chattering removal strength adjustment	50
7.2.5	+R/-R terminal reverse logic.....	50
7.2.6	CV target source.....	51
7.2.7	CC target source.....	52
7.2.8	Communication CV target	53
7.2.9	Communication CC target.....	54
7.2.10	CV rising time	55
7.2.11	CC rising time	55
7.2.12	CV transition time.....	56

7.2.13	CC transition time	56
7.2.14	OVP setting	57
7.2.15	OCP setting	57
7.2.16	VPF terminal function selection	58
7.2.17	CPF terminal function selection.....	58
7.2.18	VPF mode	59
7.2.19	CPF mode.....	59
7.2.20	PF filter	60
7.2.21	VPF tracking threshold	61
7.2.22	VPF fixed threshold	61
7.2.23	CPF tracking threshold.....	62
7.2.24	CPF fixed threshold	62
7.2.25	VPF hysteresis	63
7.2.26	CPF hysteresis.....	63
7.2.27	Terminal output control 1	64
7.2.28	Terminal output control 2.....	64
7.2.29	Server Address	65
7.2.30	Baud Rate.....	66
7.2.31	Parity & Stop Bit.....	67
7.2.32	Response transmission waiting time	68
7.2.33	Communication settings forced default	69
7.2.34	Server address consecutive assignment	70
7.2.35	Scratch pad 1	71
7.2.36	Scratch pad 2.....	71
7.2.37	Factory reset.....	72
7.2.38	Log read reset.....	72
8	NOTE.....	73

2 Overview

HWS3000G series has the following two models.

In this communication manual, these two models are hereinafter collectively referred to as HWS3000x.

- HWS3000G : Single phase input model
- HWS3000GT : Three-phase input model

The HWS3000x can monitor operating status and change various settings via Modbus communication. The Modbus-RTU protocol with RS-485 as the physical layer is used as the communication method. Modbus-RTU communication is a single client/multi-server communication method. Here, the client is customer equipment such as a PC or PLC, and the server is HWS3000x.

In the Modbus communication method, the client issues a request and the server returns a response.

Requests are issued by the client only. If the request is unicast, only the server to which the request is addressed will return a response.

If the request is broadcast, all servers will process the request, and all servers will not return a response.

If the server receives an invalid request frame, it will discard the request and will not respond (waiting for the next request).

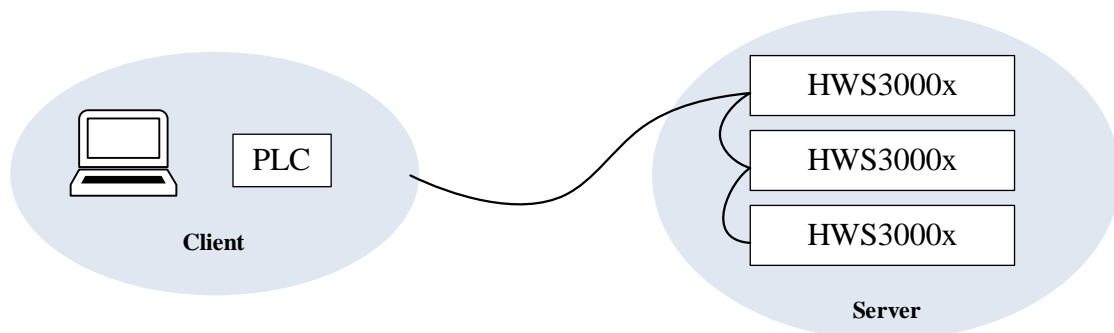

Figure 2-1 Overview

3 Communication system wiring and connections

3.1 HWS3000x series communication terminal

Pin assignments for communication connectors are shown in Table 3-1.

Table 3-1 Pin assignment of communication connector

Pin #		Signal	Note
CN41	CN42		
1		-D	RS-485 differential data -
2		+D	RS-485 differential data +
3		-DR	Terminating resistor terminal for RS-485
4, 6		DG	Digital ground
5	-	A / I	Power supply address assignment input terminal
-	5	A / O	Power supply address assignment output terminal
8		PWR	5V application terminal

NOTE: Pin #5 has different signals for CN41 and CN42.

The terminals in Table 3-1 Pin assignment of communication connector are reinforced insulated from the power input/output.

For details, please refer to "7. Block diagram" in the instruction manual.

3.2 Connection with client

Typical RS-485 bus line connection is shown in Figure 3-1.

A terminating resistor is required to communicate with RS-485. Inserting a terminating resistor suppresses reflections and improves signal quality.

Place the terminating resistor in two places: the RS-485 port of the client device and the RS-485 port of the server device furthest from the client on the bus line.

NOTE: Be sure to use twisted pair wires to connect the RS-485 bus line. If you do not use twisted pair wires or connect a terminating resistor, the signal quality will deteriorate and there is a risk of communication errors or communication failure.

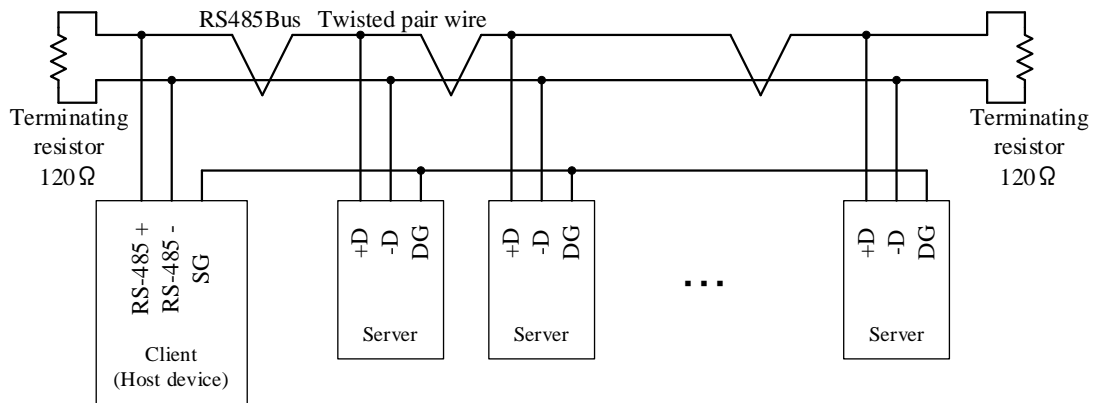

Figure 3-1 Connection basics

An example of a connection between a client and HWS3000x is shown in Figure 3-2.

Solid lines must be wired when using Modbus communication.

Dotted lines are optional. When in use, connect as shown in the figure below.

- A) When using built-in 120Ω terminating resistor of HWS3000x
- B) When supplying power to PWR terminal
See 4.2 Power supply for detail.
- C) When setting unique server addresses two or more units
See 4.3 Setting unique server addresses and 7.2.34 Server address consecutive assignment.

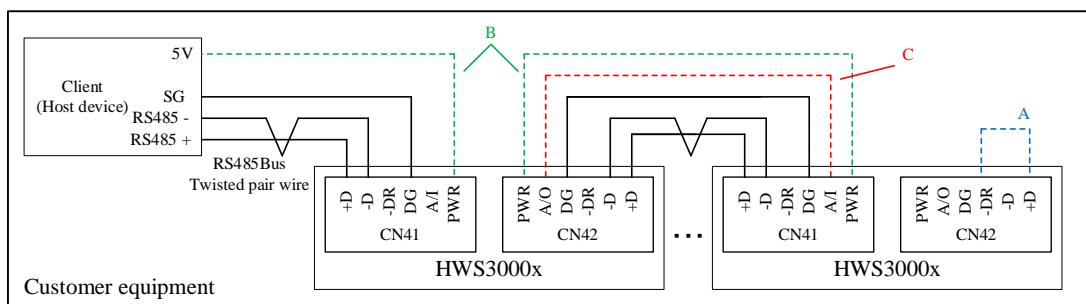

Figure 3-2 Actual wiring

Each HWS3000x can be daisy chained. When making a daisy chain connection, connect the HWS3000x's CN42 terminal and next HWS3000x's CN41 terminal.

Appropriate termination resistance value depends on factors such as wiring length. HWS3000x has a commonly used 120Ω termination resistor. To enable the built-in terminating resistor, connect the +D and -DR terminals. In this case, please evaluate the product thoroughly in the environment in which it will be used. If it is desirable to match resistance value to customer equipment, please attach an external terminating resistor between the +D and -D terminals. For the terminal resistance settings of the client, please refer to the instruction manual of the client.

4 HWS3000x setup

4.1 Server address and serial communication settings

The default value of HWS3000x server address is “1”. If you want to connect multiple HWS3000x, you need to setup them and assign a unique server address.

NOTE: If you connect multiple HWS3000x without changing the server address, all HWS3000x will respond to the same request and you will not receive a normal response.

HWS3000x can change the communication configuration.

To change communication configurations, use the communication function.

The default values for communication configuration are shown in Table 4-1.

Table 4-1 Default communication configuration

Communication configuration	Default setting value	Setting change register
Server address	1	Server Address (refer to 7.2.29)
Communication speed	115200 bps	Baud Rate (refer to 7.2.30)
Parity setting	Even parity	Parity & Stop Bit (refer to 7.2.31)
Stop bit	1bit	
Data length	8bit	Cannot be changed

4.2 Power supply

This is a specification that changes the communication configuration using communication function, therefore it is necessary to supply power to HWS3000x.

There are two methods of power supply. The first method is to apply voltage to the input terminals as in normal operation. The second method is to apply 5V to the PWR terminal. You can communicate with HWS3000x without applying voltage to the input terminal by supplying power to the PWR terminal.

The electrical specifications of the PWR terminal are as shown in Table 4-2 PWR terminal specifications.

The PWR terminal can be connected in a daisy chain.

- The current consumption of the PWR terminal increases according to the number of connected units. Be noted of the capacity of the power source.
- The PWR terminal supports up to 1A.
- Please be careful that the PWR terminal voltage does not fall outside the specified range due

to line drop.

Table 4-2 PWR terminal specifications

PWR terminal input voltage	Current consumption
4.75 - 5.25V	30mA × number of connected devices *up to 1A

NOTE: If voltage is applied to both the input terminal and PWR terminal, the power output will be cut off due to the protection operation. This protection function differs from normal latch protection operation and cannot be canceled by turning off the remote control. The protection will be canceled by stopping voltage input to the PWR terminal and HWS3000x input and waiting about 3 minutes.

4.3 Setting unique server addresses

There are two methods to set unique server addresses.

< Set individually >

Connect the client and HWS3000x one-to-one in advance and change the server address.

< Set all units >

Connect the A/O and A/I terminals of the HWS3000x in daisy chain and set them all to a unique server address. When using the A/O and A/I terminals, the client can assign unique server addresses even if the server addresses are duplicated. Refer to 7.2.34 Server address consecutive assignment.

4.4 If you forget the serial communication settings

There is no function to display the server address or serial communication settings on the HWS3000x itself. Please keep a copy of the changed communication settings. If you forget communication settings, use “Communication settings forced default” register in broadcast for all baud rate, parity and stop bit combinations.

Our GUI has dedicated buttons to perform the above operations.

5 Communication specifications

5.1 Transmission specifications

Table 5-1 Transmission specifications

Item	Specification												
Electrical specifications													
Signal ground	Reinforced insulation from primary side input and secondary side output												
Transceiver voltage	5V												
Transmission standard	TIA / EIA-485												
Connection type	1 : N (Client : Server)												
Number of connected devices	Up to 30 units												
Transmission line shape	Half Duplex												
Total transmission path length	100m or less												
Response transmission display	Yellow LED lights up while sending response												
Character transmission specifications													
Character synchronization method	Asynchronous												
Character transfer speed	2400 / 4800 / 9600 / 19200 / 38400 / 57600 / 115200 bps Default value : 115200 bps												
Data bit length	8bit												
Transmission code configuration	<p>The following combinations are valid</p> <table border="1"> <thead> <tr> <th>Start</th> <th>Parity</th> <th>Stop</th> </tr> </thead> <tbody> <tr> <td>1bit</td> <td>Even</td> <td>1bit</td> </tr> <tr> <td>1bit</td> <td>Odd</td> <td>1bit</td> </tr> <tr> <td>1bit</td> <td>None</td> <td>2bit</td> </tr> </tbody> </table> <p>*Default value</p>	Start	Parity	Stop	1bit	Even	1bit	1bit	Odd	1bit	1bit	None	2bit
Start	Parity	Stop											
1bit	Even	1bit											
1bit	Odd	1bit											
1bit	None	2bit											
Transfer order	LSB first												
Flow control	None												
Character transfer interval	No limit (The data up to the frame separation is treated as continuous data.)												
Protocol specification													
Supported protocol	Modbus-RTU												

Frame separation*	T3.5 (No lower limit of 1.75 ms when above 19200 bps)
Response preparation time*	2 ms or less
Response transmission waiting time*	0 - 99 ms Default value : 20 ms
Minimum request interval*	2 ms or more

* See Figure 5-1 and Figure 5-2 for the definition.

NOTE: Time accuracy is less than $\pm 1\%$ (operating ambient temperature -20 to 70°C).

5.2 Communication protocol

5.2.1 Protocol overview

Modbus-RTU communication is a single client/multi-server communication method. A request message is always sent from the client, and the server specified by the client (unicast) sends a response upon completion of request processing.

If the server terminates request processing abnormally, an exception response will be sent.

NOTE: Requests in which a transmission error is detected are discarded, so no exception response is sent. In this case, the client should take appropriate action such as detecting the communication timeout and resending the request.

Modbus-RTU communication uses a method that separates frames based on silent interval, and silent interval is specified as T3.5 character times or more. T1 character time is the time required to transmit one character and is the time for 11 bits including Start Bit + Data (8bit) + Parity Bit + Stop Bit.

T3.5 is 3.5 times longer than T1. This time depends on the baud rate. Table 5-2 shows the T3.5 silent interval for each baud rate. Additionally, Figure 5-1 shows an example of unicast request and response between the client and the server.

Table 5-2 T3.5 silent interval for each baud rate

bps	2400	4800	9600	19200	38400	57600	115200
T3.5 [ms]	16.1	8.1	4.1	2.1	1.1	0.7	0.4

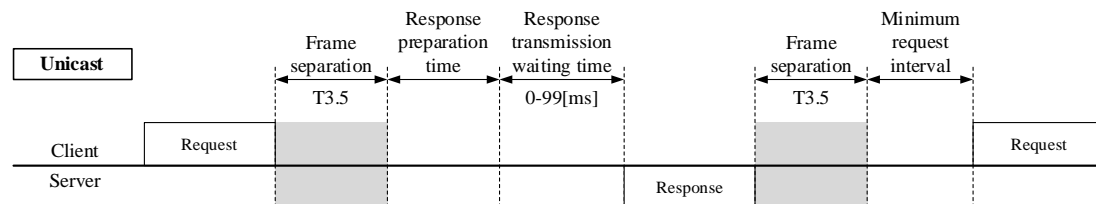

Figure 5-1 Unicast

NOTE: Set a sufficiently large value for the communication timeout of the client, taking into consideration the T3.5 character time used as a frame separation, response preparation time, and response transmission waiting time in Table 5-1 Transmission specifications. Also, leave the minimum request interval as shown in Table 5-1 Transmission specifications between the completion of response transmission and the next request.

When issuing a request to all servers (broadcast), each server only processes the request and does not return a response. The transmission interval of the client must comply with the minimum request interval specified in Table 5-1 Transmission specifications. Figure 5-2 shows an example

of broadcast request between the client and the server.

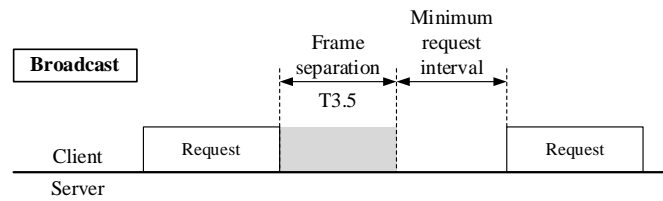

Figure 5-2 Broadcast

5.2.2 Protocol details

For specifications of the Modbus protocol, please refer to the documents below.

Publisher : Modbus Organization (<http://modbus.org/>)

MODBUS APPLICATION PROTOCOL SPECIFICATION V1.1b

(Modbus_Application_Protocol_V1_1b3.pdf)

MODBUS over Serial Line Specification and Implementation Guide V1.02

(Modbus_over_serial_line_V1_02.pdf)

5.2.3 Non-supported specifications

HWS3000x does not support some items listed in 5.2.2 Protocol details.

- It is recommended that the lower limit of frame separation be 1.75ms, but HWS3000x does not limit the lower limit. Frame separation is done based on T3.5 character time, which depends on the baud rate. However, since there is a "response transmission waiting time" after receiving the unicast request and before sending the response, the response will not be returned immediately after the frame is separated. The default value is a response transmission waiting time greater than 1.75ms.

- Character reception interval abnormality (reception interval > T1.5 character time) is not detected. If the character reception interval is within the frame separation time, it is recognized as one frame.

- Only function codes for 16-bit registers are supported. Refer to 5.4 HWS3000x support function code for details.

- If the start address is not one of the addresses specified in each register, an exception response will be returned.

- If it is not accessed with the specified size, an exception response will be returned. When

accessing a register with a register size of 2 words or more, please access the size determined by each register.

5.3 Message frame configuration

In Modbus-RTU, all data in a message frame is called ADU (serial line Application Data Unit). The data that is analyzed as a protocol is called PDU (Protocol Data Unit).

5.3.1 Request frame

The Modbus-RTU request message frame consists of the fields shown in Figure 5-3 Request frame.

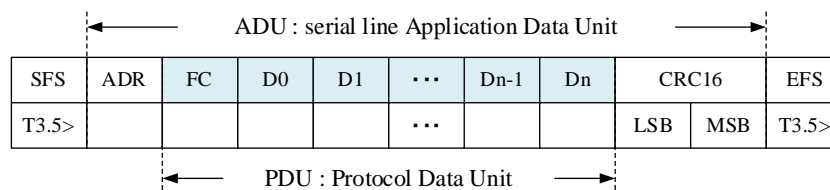

Figure 5-3 Request frame

< SFS (Start Frame Separation) >

This is the silent interval that is longer than T3.5 character time that separates frames.

< ADR (Server Address) >

This is the address that specifies the server to communicate with.

0 means Broadcast.

Table 5-3 Server address

Address number	Meaning
0	Broadcast address
1 - 247	Individual server address
248 - 255	Reserved address

< FC (Function Code) >

This is the code that specifies the type of register to be accessed and the process to be performed on that register

Refer to Table 5-6 for details.

< Dn (Data bytes) >

This is a data entry field. Data format depends on the FC. For details, see 5.4 HWS3000x support function code.

Multi-byte data is big endian. HWS3000x applies the byte order shown in Table 5-4 to each data type.

Table 5-4 Data configuration

	Register offset	0		1	
	Byte offset	0	1	2	3
Data type	16 bit type	Upper byte	Lower byte		
	32 bit type	Upper byte of upper word	Lower byte of upper word	Upper byte of lower word	Lower byte of lower word
	String type	C0	C1	C2	C3

*C0,C1 ... C3 is character byte

Example) 32-bit type data"0x12345678"

⇒ Dn (Data bytes) is D0 : 0x12, D1 : 0x34, D2 : 0x56, D3 : 0x78

NOTE: The data byte order of the frame does not necessarily match the endianness of the client device processor.

< CRC16 (Cyclical Redundancy Checking) >

This is the 16-bit cyclic redundancy check value from ADR to Dn

The Modbus-RTU CRC is a so-called reverse 16-bit CRC-IBM.

Generator polynomial : 0xA001 (inverted 0x8005)

CRC initial value : 0xFFFF

Final XOR operation : None

Example) Issue the following request to the server with ADR: 1.

Starting address : 0x0001

Number of registers : 3

Register read : FC : 0x04

SFS	ADR	FC	D0	D1	D2	D3	CRC16		EFS
T3.5>	0x01	0x04	0x00	0x01	0x00	0x03	0xE1	0xCB	T3.5>

Figure 5-4 Request example with FC:0x04

For more information, see section 6.2.2 of the MODBUS over Serial Line Specification and Implementation Guide.

NOTE: Only the CRC field is little endian (lower byte, upper byte), so care must be taken regarding the transmission order.

< EFS (End Frame Separation) >

This is the non-communication time is longer than the T3.5 character time that separates frames.

5.3.2 Response frame

The Modbus-RTU response message frame consists of the fields shown in Figure 5-5 Normal

response frame.

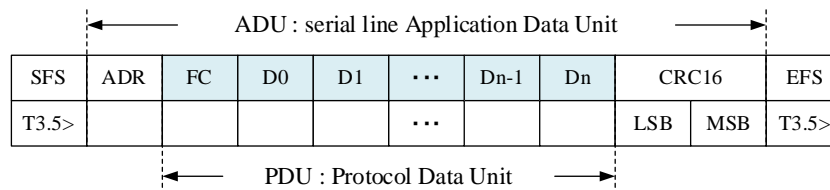

Figure 5-5 Normal response frame

The structure of each field is the same as the request frame. The ADR and FC field values of the response frame will contain the same values as the request. The format of the data field varies depending on the FC. For details, see 5.4 HWS3000x support function code.

5.3.3 Exception response frame

The Modbus-RTU exception response message frame consists of the fields shown in Figure 5-6 Exception response frame.

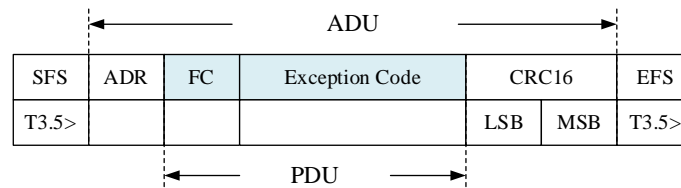

Figure 5-6 Exception response frame

< FC (Function Code) >

The exception response FC is request FC + 0x80.

Example) Exception response to the request FC: 0x10 ⇒ 0x90

< Exception Code >

A 1-byte code that indicates the contents of the exception. For HWS3000x, the exception code shown in Table 5-5 Exception response code may be returned.

Other fields are the same as the request frame.

Table 5-5 Exception response code

Code	Exception name	Exception details
0x01	ILLEGAL FUNCTION	Unsupported function code
0x02	ILLEGAL DATA ADDRESS	Undefined register address (including undefined addresses)
0x03	ILLEGAL DATA VALUE	Invalid data

5.4 HWS3000x support function code

HWS3000x supports the function codes (FC) shown in Table 5-6 Support function code.

Table 5-6 Support function code

FC	Data Type	Access target	Function name
4 (0x04)	16 bit	Input Register	Read Input Registers
3 (0x03)	16 bit	Holding Register	Read Holding Registers
6 (0x06)	16 bit	Holding Register	Write Single Register
16 (0x10)	16 bit	Holding Register	Write Multiple registers
23 (0x17)	16 bit	Holding Register	Read/Write Multiple registers

In the following descriptions of function codes, ADR and CRC will be omitted for simplicity.

5.4.1 FC : 4 (0x04) Read Input Registers

Reads the contents of consecutive Input registers. Broadcasting is disabled.

Acquires continuous data starting from the register specified as the Starting address.

Table 5-7 Read Input Registers request PDU

Field	Number of bytes	Field value
Function Code	1	0x04
Starting address	2	Refer to 7.1 Input Registers
Number of registers	2	N

Table 5-8 Read Input Registers normal response PDU

Field	Number of bytes	Field value
Function Code	1	0x04
Number of data bytes	1	2 x N
Register data	N x 2	Read data

N = Number of registers specified in the request

Table 5-9 Read Input Registers exception response PDU

Field	Number of bytes	Field value
Function Code	1	0x84
Exception Code	1	Refer to Table 5-5 Exception response code

NOTE: If undefined addresses are included in the specified register address range [starting address ~ (starting address + number of registers - 1)], or If the request is a partial read of data consisting of multiple registers, an exception response [Exception code 0x02: ILLEGAL DATA

ADDRESS] is returned. If the request PDU size is not the legal size (5 bytes), an exception response [Exception code 0x03: ILLEGAL DATA VALUE] will be returned.

•Request/response example

Read 2 words of Input register from starting address 2 (0x0002).

Table 5-10 Request/response example by Read Input Registers

Request		Response	
Field	[HEX]	Field	[HEX]
Function Code	0x04	Function Code	0x04
Starting address Hi	0x00	Number of data bytes	0x04
Starting address Lo	0x02	Register 0x0002 Hi	0x0F
Number of registers Hi	0x00	Register 0x0002 Lo	0xA0
Number of registers Lo	0x02	Register 0x0003 Hi	0x07
		Register 0x0003 Lo	0xD0

The following can be deciphered from the above response.

Output voltage : 4000 (0x0FA0)

Output current : 2000 (0x07D0)

*Refer to 7.1.3 Output voltage and 7.1.4 Output current for unit conversion to [V] and [A].

5.4.2 FC : 3 (0x03) Read Holding Registers

Reads the contents of consecutive Holding registers. Broadcasting is disabled.

Acquires continuous data starting from the register specified as the Starting address.

Table 5-11 Read Holding Registers request PDU

Field	Number of bytes	Field value
Function Code	1	0x03
Starting address	2	Refer to 7.2 Holding Registers
Number of registers	2	N

Table 5-12 Read Holding Registers normal response PDU

Field	Number of bytes	Field value
Function Code	1	0x03
Number of data bytes	1	2 x N
Register data	N x 2	Read data

N = The number specified in the number of registers field in the request

Table 5-13 Read Holding Registers exception response PDU

Field	Number of bytes	Field value
Function Code	1	0x83
Exception Code	1	Refer to Table 5-5 Exception response code

NOTE: If undefined addresses are included in the specified register address interval [starting address to (starting address + number of registers - 1)], or If the request is a partial read of data consisting of multiple registers, an exception response [Exception code 0x02: ILLEGAL DATA ADDRESS] is returned. If the request PDU size is not the legal size (5 bytes), an exception response [Exception code 0x03: ILLEGAL DATA VALUE] will be returned.

•Request/response example

Read 2 words of Holding register from starting address 530 (0x0212).

Table 5-14 Request/response example by Read Holding Registers

Request		Response	
Field	[HEX]	Field	[HEX]
Function Code	0x03	Function Code	0x03
Starting address Hi	0x02	Number of data bytes	0x04
Starting address Lo	0x12	Register 0x0212 Hi	0x01
Number of registers Hi	0x00	Register 0x0212 Lo	0x90
Number of registers Lo	0x02	Register 0x0213 Hi	0x0E
		Register 0x0213 Lo	0x10

The following can be deciphered from the above response.

VPF tracking threshold : 0x0190

VPF fixed threshold : 0x0E10

5.4.3 FC : 6 (0x06) Write Single Register

Update the content of a single Holding register. Broadcast is possible.

Writes data to the register specified by the Start address.

Table 5-15 Write Single Register Request PDU

Field	Number of bytes	Field value
Function Code	1	0x06
Starting address	2	Refer to 7.2 Holding Registers
Register data	2	Write data

Table 5-16 Write Single Register Normal Response PDU

Field	Number of bytes	Field value
Function Code	1	0x06
Starting address	2	Refer to 7.2 Holding Registers
Register data	2	Write data echo back

Table 5-17 Write Single Register Exception Response PDU

Field	Number of bytes	Field value
Function Code	1	0x86
Exception Code	1	Refer to Table 5-5 Exception response code

NOTE: If the specified Starting address is an undefined address, or if a data consisting of multiple registers is specified as the Starting address, an exception response [Exception code 0x02: ILLEGAL DATA ADDRESS] will be returned. If the request PDU size is not the legal size (5 bytes) or if the register data is outside the allowable range, an exception response [Exception code 0x03: ILLEGAL DATA VALUE] will be returned.

• Request/response example

Write data 0x0001 to Holding register starting address 0 (0x0000)

Table 5-18 Request/response example by Write Single Register

Request		Response	
Field	[HEX]	Field	[HEX]
Function Code	0x06	Function Code	0x06
Starting address Hi	0x00	Starting address Hi	0x00
Starting address Lo	0x00	Starting address Lo	0x00
Register data Hi	0x00	Register data Hi	0x00
Register data Lo	0x01	Register data Lo	0x01

The following can be deciphered from the above response.

Write “ON” (0x0001) to Remote control ON register (0x0000)

5.4.4 FC : 16 (0x10) Write Multiple registers

The contents of consecutive Holding registers can be updated. Broadcast is possible.

Write continuous data starting from the register specified as the Starting address.

Table 5-19 Write Multiple registers request PDU

Field	Number of bytes	Field value
Function Code	1	0x10
Starting address	2	Refer to 7.2 Holding Registers
Number of registers	2	N
Number of data bytes	1	2 x N
Register data	N x 2	Write data

Table 5-20 Write Multiple registers Normal Response PDU

Field	Number of bytes	Field value
Function Code	1	0x10
Starting address	2	Refer to 7.2 Holding Registers
Number of registers	2	N

N = The number specified in the number of registers field in the request

Table 5-21 Write Multiple registers Exception Response PDU

Field	Number of bytes	Field value
Function Code	1	0x90
Exception Code	1	Refer to Table 5-5 Exception response code

NOTE: If undefined addresses are included in the specified register address range [starting address to (starting address + number of registers - 1)], or if the request is a partial write of data consisting of multiple registers, an exception response [Exception code 0x02: ILLEGAL DATA ADDRESS] is returned. If the request PDU size is not a legal size or the register data is outside the allowable range, an exception response [Exception code 0x03: ILLEGAL DATA VALUE] will be returned.

•Request/response example

Write 2 words of Holding register from starting address 110 (0x006E)

Table 5-22 Request/response example by Write Multiple registers

Request		Response	
Field	[HEX]	Field	[HEX]
Function Code	0x10	Function Code	0x10
Starting address Hi	0x00	Starting address Hi	0x00
Starting address Lo	0x6E	Starting address Lo	0x6E
Number of registers Hi	0x00	Number of registers Hi	0x00
Number of registers Lo	0x02	Number of registers Lo	0x02
Number of data bytes	0x04		
Register 0x006E data Hi	0x0F		
Register 0x006E data Lo	0xA0		
Register 0x006F data Hi	0x0F		
Register 0x006F data Lo	0xA0		

The following can be deciphered from the above response.

Write 2 registers starting from the Communication CV target register (0x006E)

*The contents of the write are not returned in response to a Write Multiple registers.

5.4.5 FC : 23 (0x17) Read/Write Multiple registers

Read and write consecutive Holding registers in a single request. Write processing is executed before read processing. Broadcasting is possible and write processing is performed, but reading is ignored because no response is returned.

Write/Read continuous data starting from the register specified as the Starting address.

Table 5-23 Read/Write Multiple registers request PDU

Field	Number of bytes	Field value
Function Code	1	0x17
Read Starting Address	2	Refer to 7.2 Holding Registers
Number of read registers	2	M
Write Starting Address	2	Refer to 7.2 Holding Registers
Number of write registers	2	N
Number of write bytes	1	2 x N
Write data	N x 2	Write data

Table 5-24 Read/Write Multiple registers normal response PDU

Field	Number of bytes	Field value
Function Code	1	0x17
Number of read bytes	1	2 x M
Register data	M x 2	Read data

M = The number of registers specified in the number of read registers field in the request

Table 5-25 Read/Write Multiple registers exception response PDU

Field	Number of bytes	Field value
Function Code	1	0x97
Exception Code	1	Refer to Table 5-5 Exception response code

NOTE: If undefined addresses are included in the specified register address range [starting address ~ (starting address + number of registers - 1)], or if the request is a partial write/read of data consisting of multiple registers, an exception response [Exception code 0x02: ILLEGAL DATA ADDRESS] is returned. If the request PDU size is not a legal size or the register data is outside the allowable range, an exception response [Exception code 0x03: ILLEGAL DATA VALUE] will be returned.

•Request/response example

Read one word of Holding register from starting address 100 (0x0064) and write one word of Holding register from starting address 110 (0x006E)

Table 5-26 Request/response example by Read/Write Multiple registers

Request		Response	
Field	[HEX]	Field	[HEX]
Function Code	0x17	Function Code	0x17
Read Starting Address Hi	0x00	Number of read bytes	0x02
Read Starting Address Lo	0x64	Register 0x0064 data Hi	0x00
Number of read registers Hi	0x00	Register 0x0064 data Lo	0x02
Number of read registers Lo	0x01		
Write Starting Address Hi	0x00		
Write Starting Address Lo	0x6E		
Number of write registers Hi	0x00		
Number of write registers Lo	0x01		
Number of write bytes	0x02		
Register 0x006E data Hi	0x0F		
Register 0x006E data Lo	0xA0		

The following can be deciphered from the above response.

CV target source register (0x0064) : Communication CV target (0x0002)

5.5 HWS3000x Support diagnostic function

HWS3000x supports some of the diagnostic functions specified by the Modbus protocol. The diagnostic function is specified by a function code (FC): 0x08 request, and the diagnostic function detail is specified by a subcode (SC).

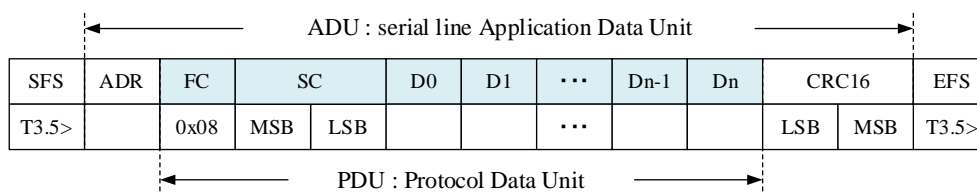

Figure 5-7 Diagnostic function request frame

Table 5-27 shows a list of supported diagnostic functions.

Table 5-27 Supported diagnostic functions

FC	SC	Function name
0x08	1 (0x0001)	Restart Communications Option
	4 (0x0004)	Force Listen Only Mode

5.5.1 SC : 1 (0x0001) / Restart Communications Option

Initializes the HWS3000x communication port according to the currently held configuration register value. The response is made using the existing communication settings before the communication port restart process. However, no response is returned in receive-only mode.

If you have changed the server address, baud rate, or parity settings, use this function to apply the changes so that the changed settings become effective.

Table 5-28 Restart Communications Option request PDU

Field	Number of bytes	Value
FC	1	0x08
SC	2	0x0001
Data	2	0x0000 or 0xFF00

*Requests for data other than those listed will result in an exception response.

5.5.2 SC : 4 (0x0004) / Force Listen Only Mode

Set HWS3000x to receive only mode. When set to this mode, HWS3000x will ignore all requests and take no action or response. However, only SC : 1 (0x0001) / Restart Communications Option of the support diagnostic function is accepted, and it is possible to restart the communication port and cancel the Receive only mode.

Table 5-29 Force Listen Only Mode request PDU

Field	Number of bytes	Value
FC	1	0x08
SC	2	0x0004
Data	2	0x0000

*Requests for data other than those listed will result in an exception response.

6 Register list

6.1 Input Registers

The Input registers are read-only 16-bit data registers which have mainly measurement data.

Broadcasting is disabled. Data read is performed by requesting function code: 0x04.

You can get the same value regardless of whether you use Native or Common for Address. Native is a contiguous address, so you can get more information with one request.

Additionally, all addresses not listed in Table 6-1 Input Registers are undefined addresses, and access to undefined addresses will result in an exception response.

Table 6-1 Input Registers

Register Name	Address		Size (word)	Note
	Native	Common		
Status	0	-	1	Returns power supply status.
Warning	1	-	1	Returns power supply warning information.
Output voltage	2	100	1	Returns the output voltage. Scale is 0-4000 from 0V to rated output voltage.
Output current	3	101	1	Returns the output current. Scale is 0-4000 from 0A to maximum output current.
Ambient temperature	4	350	1	Returns the ambient temperature of the power supply as the Celsius temperature of Q4.
Cumulative power output time	5	400	2	Returns the time that the power was output so far in unit [seconds].
Cumulative power supply time	7	402	2	Returns the time that the power was turned on so far in unit [seconds].
CV target confirmation	9	200	1	Returns the CV target. Scale is 0-4000 from 0V to rated output voltage.
CC target confirmation	10	201	1	Returns the CC target. Scale is 0-4000 from 0A to maximum output current.
rsvd	11	420	1	This is the reserved address. Returns an indeterminate value.

Register Name	Address		Size (word)	Note
	Native	Common		
rsvd	12	421	1	This is the reserved address. Returns an indeterminate value.
AUX output voltage	13	300	1	Returns the AUX output voltage. Scale is 0-4000 from 0V to 5V.
DelayOCP integrated value	14	-	1	Returns the DelayOCP operating status in unit [%]. When it reaches 100%, the power output will be cut off.
Model name	-	500	15	Returns the product model name as ASCII characters.
Serial No.	-	520	8	Returns the product serial number as ASCII characters.
Lot No.	-	540	8	Returns the product lot number as ASCII characters.
Rated output voltage value	-	560	2	Returns the rated output voltage in [V]. Returns the integer part and decimal part separately.
Maximum output current value	-	562	2	Returns the maximum current in [A]. Returns the integer part and decimal part separately.
Maximum output power value	-	564	2	Returns the maximum power in [W]. Returns the integer part and decimal part separately.
Minor alarm log read	-	600	4	Returns data for one event from the saved log for each minor alarm event.
Major alarm log read	-	610	4	Returns data for one event from the saved log for each major alarm event.
Firmware version	-	1000	2	Returns the firmware version of the power supply control program.

6.2 Holding Registers

The Holding registers are 16-bit readable/writable data registers. It mainly contains data that can be changed from the host device, such as power supply settings. In the description of each register in 7.2 Holding Registers, if a "Yes" is written in the Non-Volatile column, the setting will be retained even after the input is interrupted. Broadcasting is disabled for read requests.

Data read is performed using a request with function code: 0x03.

Data write is performed using a request with function code: 0x06 and 0x10.

By requesting function code: 0x17, registers can be read and written all at once.

Additionally, all addresses not listed in Table 6-2 Holding Registers are undefined addresses, and access to undefined addresses will result in an exception response.

Table 6-2 Holding Registers

Register Name	Address	Size (word)	Note
Remote control ON	0	1	Turn ON/OFF the power supply output.
Remote control source selection	10	1	Select the signal source for remote control.
Communication CNT storage	11	1	Select whether to restore the "Remote control ON" register state when the power input is cut off and then turned on again.
Chattering removal strength adjustment	12	1	Chattering removal strength of the remote control terminal can be changed.
+R/-R terminal reverse logic	13	1	Remote control terminal logic can be reversed.
CV target source	100	1	Select the CV target from output voltage variable volume, CV terminal, or communication.
CC target source	101	1	Select the CC target from CC terminal or communication.
Communication CV target	110	1	CV target can be changed via communication.
Communication CC target	111	1	CC target can be changed via communication.
CV rising time	120	1	Change the time that the output voltage rises when the power output is started.
CC rising time	121	1	Change the time that the output current rises when the power output is started.

Register Name	Address	Size (word)	Note
CV transition time	125	1	Change the response time when the CV target is changed during power output.
CC transition time	126	1	Change the response time when the CC target is changed during power output.
OVP setting	200	1	Hiccup mode and latch stop operation can be selected as the operation when overvoltage occurs.
OCP setting	201	1	Hiccup mode, latch stop, and constant current limit with automatic recovery can be selected as the operation when overcurrent occurs.
VPF terminal function selection	500	1	Assign different function to the VPF terminal.
CPF terminal function selection	501	1	Assign different function to the CPF terminal.
VPF mode	510	1	VPF signal operation mode can be switched between threshold tracking mode and threshold fixed mode.
CPF mode	511	1	CPF signal operation mode can be switched between threshold tracking mode and threshold fixed mode.
PF filter	520	1	Set a filter to reduce fluttering in the PF signal output.
VPF tracking threshold	530	1	Set the threshold when using VPF signal in threshold tracking mode.
VPF fixed threshold	531	1	Set the threshold when using VPF signal in fixed threshold mode.
CPF tracking threshold	540	1	Set the threshold when using CPF signal in threshold tracking mode.
CPF fixed threshold	541	1	Set the threshold when using CPF signal in fixed threshold mode.
VPF hysteresis	550	1	Set the amount of hysteresis to reduce fluttering in the VPF signal output.
CPF hysteresis	551	1	Set the amount of hysteresis to reduce fluttering in the CPF signal output.

Register Name	Address	Size (word)	Note
Terminal output control 1	590	1	Set open/short of the VPF/CPF terminal when its function is set to terminal output control.
Terminal output control 2	591	1	
Server Address	700	1	Set the server address for Modbus-RTU communication.
Baud Rate	701	1	Set the baud rate for Modbus-RTU communication.
Parity & Stop Bit	702	1	Set the parity for Modbus-RTU communication.
Response transmission waiting time	703	1	Adjust the delay time for returning a response after receiving a request via Modbus-RTU communication.
Communication settings forced default	720	1	Set communication settings to factory default. This is a broadcast-only register.
Server address consecutive assignment	721	1	Set the server address continuously using A/I and A/O terminals. This is a broadcast-only register.
Scratch pad 1	800	15	Use to store any string data.
Scratch pad 2	820	15	
Factory reset	900	1	Return the settings except communication settings to the factory default settings.
Log read reset	910	1	Reset log reference destination.

7 Register details

7.1 Input Registers

7.1.1 Status

Register name	Data type	Address	Size
Status	Input	0 (0x0000)	1

This register indicates the status of the power supply output shutdown or protection operation. If any bit is set, it indicates that the operation outlined in Overview of Table 7-1 are active. If all bits are clear, it means the power is outputting. When the operation factor is removed, the target bit is cleared. However, if latch stop protection occurs, the bit will remain set unless all protection factors are removed and a latch stop release operation is performed.

To perform the latch stop release operation, use one of the following methods.

- Turn off the input voltage and turn it on again after a few minutes.
- Perform remote control OFF operation.

Table 7-1 Status register bit field

bit	Name	Overview
0	RC_OFF	Indicates that power output is stopped due to remote control OFF.
1	INPUTLVP	Indicates that power output is stopped due to low input voltage to the power supply.
2	UPP	Indicates that an open phase has been detected and a protective operation has occurred. Available only for three-phase input model.
3	HWOVP	Indicates that overvoltage has been detected at the power output terminal and a protective operation has occurred.
4	AdjOVP	Indicates that a voltage higher than the set value has been detected at the power output terminal and a protective operation has occurred.
5	PRIOCP	Indicates that overcurrent has been detected on the primary side of the power supply and a protective operation has occurred.
6	AdjOCP	Indicates that overcurrent has been detected on the secondary side of the power supply and a protective operation has occurred.
7	DelayOCP	Indicates that overcurrent condition continues for more than a certain period of time and a protective operation has occurred.
8	OTP	Indicates that internal temperature of the power supply is high and a protective operation has occurred.
9	FAN_ERR	Indicates that an abnormality has occurred in the FAN and a protective operation has occurred.

bit	Name	Overview
10	HALT	Indicates that a protective operation has occurred due to the HALT function.
11	EXT VCC	Indicates that power output is stopped due to external voltage applied to PWR terminal. * This bit remains set even after the external voltage applied to the PWR terminal is removed and the latch stop release operation is performed.
12	SYSTEM_ERR	Indicates that some system abnormality has occurred inside the power supply and a protective operation has occurred.
13	rsvd	It is an undefined value.
14	rsvd	It is an undefined value.
15	rsvd	It is an undefined value.

7.1.2 Warning

Register name	Data type	Address	Size
Warning	Input	1 (0x0001)	1

Displays the power supply warning information. Refer to Table 7-2 for details.

Table 7-2 Warning register bit field

bit	Name	Overview
0	VPF	Indicates that constant voltage output mode voltage shortage is occurred.
1	CPF	Indicates that constant current output mode current shortage is occurred.
2	Over input voltage	Indicates that an excessive input exceeded the specification range.
3-15	rsvd	It is an undefined value.

7.1.3 Output voltage

Register name	Data type	Address	Size
Output voltage	Input	2 (0x0002)	1
		100 (0x0064)	

This register returns the current output voltage value. It returns signed data. The scale is 0-4000 scale from 0V to the rated value. Conversion values for each voltage model are shown in Table 7-3. Values outside the minimum and maximum values are also returned, but measurement accuracy is not guaranteed.

Table 7-3 Output voltage value

	MIN	RATED	MAX	
Register value	0	4000	4400	4800
Percentage	0%	100%	110%	120%
HWS3000x-24	0.0V	24.0V	-	28.8V
HWS3000x-48	0.0V	48.0V	52.8V	-
HWS3000x-60	0.0V	60.0V	66.0V	-
HWS3000x-130	0.0V	130.0V	-	156.0V

<Calculation formula>

$$\text{Output voltage [V]} = \text{Register value} / 4000 * \text{Rated output voltage [V]}$$

7.1.4 Output current

Register name	Data type	Address	Size
Output current	Input	3 (0x0003)	1
		101 (0x0065)	

This register returns the current output current value. It returns signed data. The scale is 0-4000 scale from 0A to the maximum output current value (*). Conversion values for each voltage model are shown in Table 7-4. Values outside the minimum and maximum values are also returned, but measurement accuracy is not guaranteed.

(*) When inputting a 100V system to HWS3000G, the scale from 0A to the maximum output current value will be expressed as 0-2000, but the resolution will not change.

Table 7-4 Output current value

	MIN	MAX	
		100V input system*	200V input system
Register value	0	2000	4000
Percentage	0%	100%	100%
HWS3000x-24	0.0A	62.5A	125.0A
HWS3000x-48	0.0A	31.3A	62.6A
HWS3000x-60	0.0A	25.0A	50.0A
HWS3000x-130	0.0A	11.6A	23.2A

* HWS3000G only

<Calculation formula>

Output current [A] = Register value / 4000 * Maximum output current of 200V input system [A]

7.1.5 Ambient temperature

Register name	Data type	Address	Size
Ambient temperature	Input	4 (0x0004)	1
		350 (0x015E)	

This register returns the ambient temperature of the power supply. It returns signed data. The value read is in Q4 format. The read value can be used as the ambient temperature for HWS3000x output derating. However, the valid range of values is as listed in Table 7-5 Temperature range.

Table 7-5 Temperature range

	MIN	MAX
Register value [Q4]	-320	1600
Celsius temperature [°C]	-20	100

<Calculation formula>

$$\text{Ambient temperature [°C]} = \text{Register value} \times 2^{-4}$$

7.1.6 Cumulative power output time

Register name	Data type	Address	Size
Cumulative power output time	Input	5 (0x0005)	2
		400 (0x0190)	

This register returns the time that power was output. If the power output is stopped due to a protection function or remote control being turned off, time measurement will stop. In addition, even if the input to the power supply is cut off, the value is retained, and the next time output resumes, time measurement will start from where it left off.

Register name	MIN	MAX	INITIAL	Unit
Cumulative power output time	0	2147483647 (0x7FFFFFFF)	0	seconds

7.1.7 Cumulative power supply time

Register name	Data type	Address	Size
Cumulative power supply time	Input	7 (0x0007)	2
		402 (0x0192)	

This register returns the time that the power input was on. Even if the input to the power supply is cut off, the value is retained, and the next time output resumes, time measurement will start from where it left off.

Register name	MIN	MAX	INITIAL	Unit
Cumulative power supply time	0	2147483647 (0x7FFFFFFF)	0	seconds

7.1.8 CV target confirmation

Register name	Data type	Address	Size
CV target confirmation	Input	9 (0x0009)	1
		200 (0x00C8)	

This register returns the final voltage control operating point based on the CV target input settings. It returns signed data. The scale is 0-4000 scale from 0V to the rated value. Conversion values for each voltage model are shown in Table 7-6.

Table 7-6 CV target confirmation

	MIN	RATED	MAX	
Register value	0	4000	4440	4840
Percentage	0%	100%	111%	121%
HWS3000x-24	0.0V	24.0V	-	29.0V
HWS3000x-48	0.0V	48.0V	53.3V	-
HWS3000x-60	0.0V	60.0V	66.6V	-
HWS3000x-130	0.0V	130.0V	-	157.3V

<Calculation formula>

$$\text{CV target [V]} = \text{Register value} / 4000 * \text{Rated output voltage [V]}$$

7.1.9 CC target confirmation

Register name	Data type	Address	Size
CC target confirmation	Input	10 (0x000A)	1
		201 (0x00C9)	

This register returns the final current control operating point based on the current CC target, input voltage status, and overcurrent protection settings. It returns signed data. The scale is 0-4000 scale from 0A to the maximum output current value. Conversion values for each voltage model are shown in Table 7-7.

Table 7-7 CC target confirmation

	MIN	MAX	
		100V input system*	200V input system
Register value	0	2000	4000
Percentage	0%	100%	100%
HWS3000x-24	0.0A	62.5A	125.0A
HWS3000x-48	0.0A	31.3A	62.6A
HWS3000x-60	0.0A	25.0A	50.0A
HWS3000x-130	0.0A	11.6A	23.2A

* HWS3000G only

<Calculation formula>

$$\text{CC target [A]} = \text{Register value} / 4000 * \text{Maximum output current of 200V input system [A]}$$

7.1.10 AUX output voltage

Register name	Data type	Address	Size
AUX output voltage	Input	13 (0x000D)	1
		300 (0x012C)	

This register returns the current AUX output voltage. It returns signed data. The scale is 0-4000 scale from 0V to 5V.

Table 7-8 AUX output voltage

	MIN	RATED
Register value	0	4000
Percentage	0%	100%
Common to all models	0.0V	5.0V

<Calculation formula>

$$\text{AUX output voltage [V]} = \text{Register value} / 4000 * 5[\text{V}]$$

7.1.11 DelayOCP integrated value

Register name	Data type	Address	Size
DelayOCP integrated value	Input	14 (0x000E)	1

This register returns the detection status of DelayOCP.

If the current exceeding the specifications continues to flow, the power output will be stopped by DelayOCP. If the power supply is in an overcurrent state, the value increases, and if it is within the rating, the value decreases. The value is shown as a percentage, and the power output will be stopped when it reaches 100%.

	MIN	MAX	unit
Register value	0	100	%

7.1.12 Model name

Register name	Data type	Address	Size
Model name	Input	500 (0x01F4)	15

This register returns the model name as ASCII characters.

Treat the register data as a character array of 8-bit data x 30.

The data from the beginning to the terminating character [NULL 0x00] is valid as the model name.

Table 7-9 Request/response example by read Model name register shows an example of a request and response for reading the Model name register when the model name is "HWS3000G-24".

Table 7-9 Request/response example by read Model name register

Request		Response	
Field	[HEX]	Field	[HEX]
Function Code	0x04	Function Code	0x04
Starting address Hi	0x01	Number of data bytes	0x1E
Starting address Lo	0xF4	Register 0x01F4 Hi	0x48 'H'
Number of registers Hi	0x00	Register 0x01F4 Lo	0x57 'W'
Number of registers Lo	0x0F	Register 0x01F5 Hi	0x53 'S'
		Register 0x01F5 Lo	0x33 '3'
		Register 0x01F6 Hi	0x30 '0'
		Register 0x01F6 Lo	0x30 '0'
		Register 0x01F7 Hi	0x30 '0'
		Register 0x01F7 Lo	0x47 'G'
		Register 0x01F8 Hi	0x2D '-'
		Register 0x01F8 Lo	0x32 '2'
		Register 0x01F9 Hi	0x34 '4'
		Register 0x01F9 Lo	0x00
		...	
		Register 0x0202 Lo	0x00

7.1.13 Serial No.

Register name	Data type	Address	Size
Serial No.	Input	520 (0x0208)	8

This register returns the serial number as ASCII characters.

Treat the register data as a character array of 8-bit data x 16.

The data from the beginning to the terminating character [NULL 0x00] is valid as the serial number.

7.1.14 Lot No.

Register name	Data type	Address	Size
Lot No.	Input	540 (0x021C)	8

This register returns the lot number as ASCII characters.

Treat the register data as a character array of 8-bit data x 16.

The data from the beginning to the terminating character [NULL 0x00] is valid as the lot number.

7.1.15 Rated output voltage value

Register name	Data type	Address	Size
Rated output voltage value	Input	560 (0x0230)	2

This register returns the rated output voltage value in [V]. The register size is "2", with the upper word indicating the integer part and the lower word indicating the decimal point part up to the second decimal place.

Table 7-10 Rated output voltage value

	Rated value	Register value	
		upper	lower
HWS3000x-24	24V	24	00
HWS3000x-48	48V	48	00
HWS3000x-60	60V	60	00
HWS3000x-130	130V	130	00

<Calculation formula>

Rated output voltage value [V] = Register value (upper) + Register value (lower) / 100

By using the rated output voltage value read by this register, the 0-4000 normalized value can be converted to the unit [V].

<Calculation formula>

Voltage [V] = 0-4000 normalized value from / 4000 * Rated output voltage value [V]

7.1.16 Maximum output current value

Register name	Data type	Address	Size
Maximum output current value	Input	562 (0x0232)	2

This register returns the maximum current value in [A]. The register size is "2", with the upper word indicating the integer part and the lower word indicating the decimal point part up to the second decimal place.

Table 7-11 Maximum output current value

	Maximum output current value	Register value	
		upper	lower
HWS3000x-24	125.0A	125	00
HWS3000x-48	62.6A	62	60
HWS3000x-60	50.0A	50	00
HWS3000x-130	23.2A	23	20

<Calculation formula>

Maximum output current value [A]

$$= \text{Register value (upper)} + \text{Register value (lower)} / 100$$

By using the maximum output current value read by this register, the 0-4000 normalized value can be converted to the unit [A].

<Calculation formula>

$$\text{Current [A]} = 0\text{-}4000 \text{ normalized value from} / 4000 * \text{Maximum output current value [A]}$$

7.1.17 Maximum output power value

Register name	Data type	Address	Size
Maximum output power value	Input	564 (0x0234)	2

This register returns the maximum output power value in [W]. The register size is "2", with the upper word indicating the integer part and the lower word indicating the decimal point part up to the second decimal place.

Table 7-12 Maximum output power value

	Maximum output power value	Register value	
		upper	lower
HWS3000x-24	3000.0W	3000	00
HWS3000x-48	3004.8W	3004	80
HWS3000x-60	3000.0W	3000	00
HWS3000x-130	3016.0W	3016	00

<Calculation formula>

Maximum output power value [W]

$$= \text{Register value (upper)} + \text{Register value (lower)} / 100$$

By using the maximum output power value read by this register, the 0-4000 normalized value can be converted to the unit [W].

<Calculation formula>

$$\text{Power [W]} = 0\text{-}4000 \text{ normalized value from} / 4000 * \text{Maximum output power value [W]}$$

7.1.18 Minor alarm log read

Register name	Data type	Address	Size
Minor alarm log read	Input	600 (0x0258)	4

This register returns data for one event from the saved log for each minor alarm event.

There is a log storage area for a predetermined number of times inside the power supply. Each event shown in Table 7-13 Log specification is saved as a log. If a large number of events occur and the storage area is used up, the oldest data will be overwritten.

NOTE: If the power supply is damaged during use, the log may not be saved.

Log reading registers are provided for each alarm type. Log for one event can be read in one read. Initially, log reference destination is set to the log for the latest event. Each time log is read, the log reference destination goes back to past events.

The log reference destination will be reset to the latest log under the following conditions.

- When a new Log is saved
- When 7.2.38 Log read reset is used

If a log read request is made in the condition that the log reference destination exceeds the storage area, an exception response will be returned. Therefore, all saved logs can be read by using the log read register continuously until an exception response is returned.

Table 7-13 Log specification

Type	Storage area	Event	Saved data (1 event)
Minor alarm	20 times	<ul style="list-style-type: none"> • Remote control OFF • Low input voltage • Hiccup mode • Constant current limit with automatic recovery • HALT • System error etc. 	Cumulative power supply time (2word) Status (1word) Warning (1word)
Major alarm	10 times	<ul style="list-style-type: none"> • Latch stop • System error 	

7.1.19 Major alarm log read

Register name	Data type	Address	Size
Major alarm log read	Input	610 (0x0262)	4

Refer to 7.1.18 Minor alarm log read for detail.

7.1.20 Firmware version

Register name	Data type	Address	Size
Firmware version	Input	1000 (0x03E8)	2

This register returns firmware version of the power supply control program. The register size is "2", and the firmware version is indicated by the value that is the concatenation of the hexadecimal representation of the upper word and the hexadecimal representation of the lower word.

Example) For firmware version 00010202

Upper word : 1 (0x0001)

Lower word : 514 (0x0202)

7.2 Holding Registers

7.2.1 Remote control ON

Register name	Data type	Address	Size	Non-Volatile
Remote control ON	Holding	0 (0x0000)	1	(*)

This register is used to select power output ON/OFF.

When using the remote control setting by this register, change 7.2.2 Remote control source selection to "Communication input" or "+R/-R terminal input & communication input".

* If non-volatile is selected in "7.2.3 Communication CNT storage", the previous state will be inherited. If volatile is selected, the power output will be OFF by default CNTOFF.

MIN	MAX	DATA	INITIAL
0	1	0 : CNTOFF 1 : CNTON	0

7.2.2 Remote control source selection

Register name	Data type	Address	Size	Non-Volatile
Remote control source selection	Holding	10 (0x000A)	1	Yes

This register is used to select input source of the remote control signal.

Input source signals which is not selected as remote control source are ignored.

The setting "+R/-R terminal input & communication input" means the AND condition of +R/-R terminal input and communication input (7.2.1 Remote control ON).

MIN	MAX	DATA	INITIAL
0	2	0 : +R/-R terminal input 1 : Communication input (7.2.1 Remote control ON) 2 : +R/-R terminal input & communication input	0

7.2.3 Communication CNT storage

Register name	Data type	Address	Size	Non-Volatile
Communication CNT storage	Holding	11 (0x000B)	1	Yes

This register is used to select volatile or non-volatile of remote control setting of communications (7.2.1 Remote control ON).

< Volatile >

Power output is OFF by default, and starts from OFF every time the power is turned on. However, if the interval between the previous input cutoff and the input restart is short, the previous information may be carried over.

< Non-volatile >

When the power is turned on, operation starts with the value previously set in the remote control ON register.

When CNTON is set with volatile or non-volatile, the behavior when the input restart is as shown in Figure 7-1. With volatile, the output will remain stopped, and with non-volatile, the output will return.

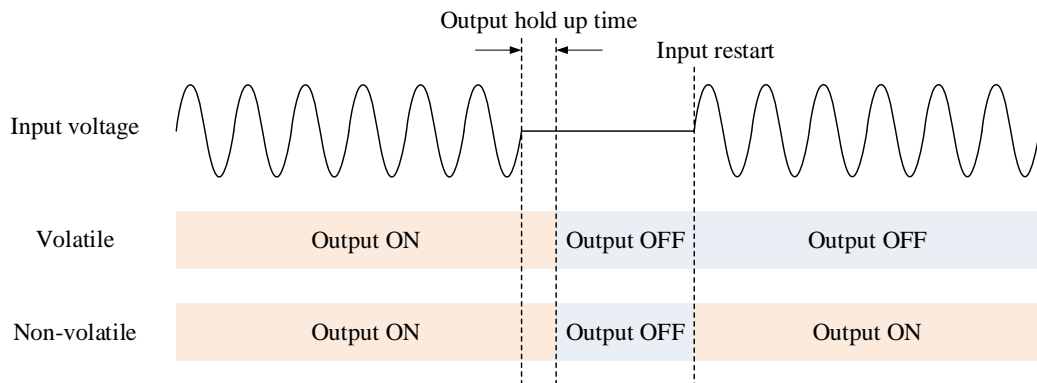

Figure 7-1 Difference between volatile and non-volatile operation

MIN	MAX	DATA	INITIAL
0	1	0 : Volatile 1 : Non-volatile	0

7.2.4 Chattering removal strength adjustment

Register name	Data type	Address	Size	Non-Volatile
Chattering removal strength adjustment	Holding	12 (0x000C)	1	Yes

This register is used to set chattering removal strength of the +R/-R terminal.

It can eliminate chattering that occurs in the +R/-R terminal signals (the voltage generated at the +R/-R terminals when an analog voltage is applied or when the terminals are shorted or opened by a switch, etc.).

The unit of setting value of this register is msec.

NOTE: The larger value set in this register, the stronger filtering time on the +R/-R terminal, but the signal response speed will decrease accordingly.

	MIN	MAX	INITIAL
Chattering removal strength adjustment	0	100	10

7.2.5 +R/-R terminal reverse logic

Register name	Data type	Address	Size	Non-Volatile
+R/-R terminal reverse logic	Holding	13 (0x000D)	1	Yes

This register is used to set the ON/OFF logic of the +R/-R terminal.

MIN	MAX	DATA	INITIAL
0	1	0 : Standard logic 1 : Reverse logic	0

7.2.6 CV target source

Register name	Data type	Address	Size	Non-Volatile
CV target source	Holding	100 (0x0064)	1	Yes

This register is used to select input source of CV target.

The default setting "VR / CV terminal" is an automatic switching type. If the CV terminal is open or short, it will operate based on the output variable volume. If voltage of 1V or more is applied to the CV terminal even once, it will operate based on the voltage applied to the CV terminal until the input voltage of the power supply is cut off.

Setting "CV terminal" means to use only the CV terminal. If changing the CV target using communication function (7.2.8 Communication CV target), set "Communication" to this register.

MIN	MAX	DATA	INITIAL
0	2	0 : VR / CV terminal 1 : CV terminal 2 : Communication	0

7.2.7 CC target source

Register name	Data type	Address	Size	Non-Volatile
CC target source	Holding	101 (0x0065)	1	Yes

This register is used to select input source of CC target.

The default setting "Constant current limit with automatic recovery / CC terminal" is an automatic switching type. If the CC terminal is open or short, it will operate based on the overcurrent protection setting will be activated. If voltage of 1V or more is applied to the CC terminal even once, it will operate based on the voltage applied to the CC terminal until the input voltage of the power supply is cut off.

Setting "CC terminal" means to use only the CC terminal. If changing the CC target using communication function (7.2.9 Communication CC target), set "Communication" to this register.

MIN	MAX	DATA	INITIAL
0	2	0 : Constant current limit with automatic recovery / CC terminal 1 : CC terminal 2 : Communication	0

7.2.8 Communication CV target

Register name	Data type	Address	Size	Non-Volatile
Communication CV target	Holding	110 (0x006E)	1	Yes

This register is used to sets communication CV target.

When using the Communication CV target for CV target, it is necessary to change 7.2.6 CV target source to "Communication".

Table 7-14 Communication CV target

	MIN	RATED	MAX		INITIAL
Register value	0	4000	4440	4840	0
Percentage	0%	100%	111%	121%	0%
HWS3000x-24	0.0V	24.0V	-	29.0V	0.0V
HWS3000x-48	0.0V	48.0V	53.3V	-	0.0V
HWS3000x-60	0.0V	60.0V	66.6V	-	0.0V
HWS3000x-130	0.0V	130.0V	-	157.3V	0.0V

<Calculation formula>

Communication CV target [V]

$$= \text{Register value} / 4000 * \text{Rated output voltage [V]}$$

7.2.9 Communication CC target

Register name	Data type	Address	Size	Non-Volatile
Communication CC target	Holding	111 (0x006F)	1	Yes

This register is used to set communication CC target.

When using the Communication CC target for CC target, it is necessary to change 7.2.7 CC target source to "Communication".

If 100V system is input to HWS3000G, maximum output current will be different. It is possible to input a CC target that exceeds the maximum output current register value in this register, but avoid using with output current that exceeds the maximum output current of the power supply.

Table 7-15 Communication CC target

	MIN	Maximum output current		MAX	INITIAL
		100V input system *	200V input system		
Register value	0	2000	4000	4040	0
Percentage	0%	100%	100%	-	0%
HWS3000x-24	0.0A	62.5A	125.0A	126.3A	0.0A
HWS3000x-48	0.0A	31.3A	62.6A	63.2A	0.0A
HWS3000x-60	0.0A	25.0A	50.0A	50.5A	0.0A
HWS3000x-130	0.0A	11.6A	23.2A	23.4A	0.0A

* HWS3000G only

<Calculation formula>

Communication CC target [A]

$$= \text{Register value} / 4000 * \text{Maximum output current of 200V input system [A]}$$

7.2.10 CV rising time

Register name	Data type	Address	Size	Non-Volatile
CV rising time	Holding	120 (0x0078)	1	Yes

This register is used to select CV rising time.

It is possible to make the output rise more gradual when the power supply starts outputting. As the setting value is increased, the rise will become more gradual. The rise time shown in Figure 7-2 is applicable.

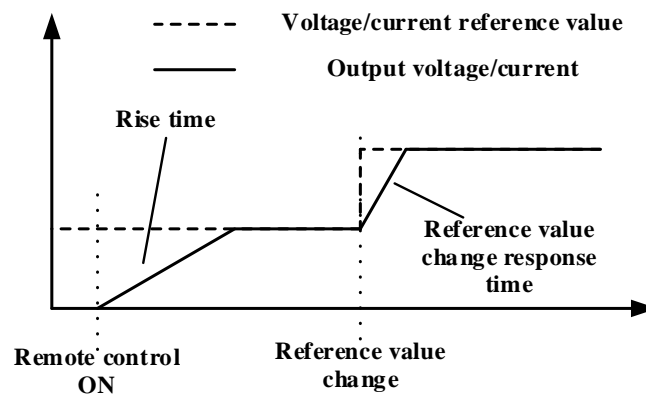

Figure 7-2 Reference value rise time and reference value response time

	MIN	MAX	INITIAL
CV rising time	0	15	0

7.2.11 CC rising time

Register name	Data type	Address	Size	Non-Volatile
CC rising time	Holding	121 (0x0079)	1	Yes

This register is used to select CC rising time.

As the setting value is increased, the rise will become more gradual. The rise time shown in Figure 7-2 is applicable.

	MIN	MAX	INITIAL
CC rising time	0	15	0

7.2.12 CV transition time

Register name	Data type	Address	Size	Non-Volatile
CV transition time	Holding	125 (0x007D)	1	Yes

This register is used to select CV transition time.

As the setting value is increased, the output rise will become more gradual when CV target is increased during constant voltage is output. The reference value change response time shown in Figure 7-2 is applicable.

	MIN	MAX	INITIAL
CV transition time	0	15	0

7.2.13 CC transition time

Register name	Data type	Address	Size	Non-Volatile
CC transition time	Holding	126 (0x007E)	1	Yes

This register is used to select CC transition time.

As the setting value is increased, the output rise will become more gradual when CC target is increased during constant current is output. The reference value change response time shown in Figure 7-2 is applicable.

	MIN	MAX	INITIAL
CC transition time	0	15	0

7.2.14 OVP setting

Register name	Data type	Address	Size	Non-Volatile
OVP setting	Holding	200 (0x00C8)	1	Yes

This register is used to select the operation when output overvoltage is detected.

MIN	MAX	DATA	INITIAL
0	1	0 : Hiccup mode 1 : Latch stop	1

7.2.15 OCP setting

Register name	Data type	Address	Size	Non-Volatile
OCP setting	Holding	201 (0x00C9)	1	Yes

This register is used to select the operation when output overcurrent is detected.

MIN	MAX	DATA	INITIAL
0	2	0 : Hiccup mode 1 : Latch stop 2 : Constant current limit with automatic recovery	2

7.2.16 VPF terminal function selection

Register name	Data type	Address	Size	Non-Volatile
VPF terminal function selection	Holding	500 (0x01F4)	1	Yes

This register is used to select function of VPF terminal of CN71.

MIN	MAX	DATA	INITIAL
0	5	0 : VPF 1 : CPF 2 : rsvd (undefined output) 3 : Terminal output control 1 (7.2.27) 4 : Terminal output control 2 (7.2.28) 5 : Latch stop signal	0

7.2.17 CPF terminal function selection

Register name	Data type	Address	Size	Non-Volatile
CPF terminal function selection	Holding	501 (0x01F5)	1	Yes

This register is used to select function of CPF terminal of CN71.

MIN	MAX	DATA	INITIAL
0	5	0 : VPF 1 : CPF 2 : rsvd (undefined output) 3 : Terminal output control 1 (7.2.27) 4 : Terminal output control 2 (7.2.28) 5 : Latch stop signal	1

7.2.18 VPF mode

Register name	Data type	Address	Size	Non-Volatile
VPF mode	Holding	510 (0x01FE)	1	Yes

This register is used to select VPF threshold behavior.

<Tracking mode>

The VPF operation threshold follows the CV target.

NOTE: If the CV target changes suddenly, the change in power supply output may not be able to catch up, and the VPF signal may be output temporarily.

<Fixed mode>

The VPF operating threshold is always constant regardless of the CV target.

If the CV target and the VPF operation threshold are close, the VPF signal may be output.

Please confirm the setting with the final device.

MIN	MAX	DATA	INITIAL
0	1	0 : Tracking mode 1 : Fixed mode	0

7.2.19 CPF mode

Register name	Data type	Address	Size	Non-Volatile
CPF mode	Holding	511 (0x01FF)	1	Yes

This register is used to select CPF threshold behavior.

<Tracking mode>

The CPF operating threshold follows the CC target.

NOTE: If the CC target changes suddenly, the change in power supply output may not be able to catch up, and the CPF signal may be output temporarily.

<Fixed mode>

The CPF operating threshold is always constant regardless of the CC target.

If the CC target and the CPF operation threshold are close, the CPF signal may be output.

Please confirm the setting with the final device.

MIN	MAX	DATA	INITIAL
0	1	0 : Tracking mode 1 : Fixed mode	0

7.2.20 PF filter

Register name	Data type	Address	Size	Non-Volatile
PF filter	Holding	520 (0x0208)	1	Yes

This register is used to set PF filter.

PF filter can be used when the PF signal reacts too quickly in an environment with large load fluctuations. Effective for both VPF and CPF.

If the output voltage or output current remains below the VPF or CPF operating threshold for longer than the time set in this register, VPF or CPF signal changes. The unit of setting value of this register is msec.

NOTE: The larger value set in this register, the stronger filter, but the signal response speed will decrease accordingly.

	MIN	MAX	INITIAL
PF filter	0	100	0

7.2.21 VPF tracking threshold

Register name	Data type	Address	Size	Non-Volatile
VPF tracking threshold	Holding	530 (0x0212)	1	Yes

This register is used to configure the operating threshold when VPF is set to tracking mode. The operating threshold is expressed as a percentage decrease from the CV target. The rate of decline is expressed in units of 0-4000 scale from 0V to the rated output voltage.

	MIN		MAX		INITIAL	
	[%]	Register value	[%]	Register value	[%]	Register value
VPF tracking threshold	5%	200	30%	1200	10%	400

<Example> Case where a rated 24V output power supply is used at 19.2V (80%)

If the VPF tracking threshold is set to 10%, 16.8V (70%) will be the threshold for the VPF signal.

Please note that it is not 10% when 19.2V is 100%.

7.2.22 VPF fixed threshold

Register name	Data type	Address	Size	Non-Volatile
VPF fixed threshold	Holding	531 (0x0213)	1	Yes

This register is used to configure the operating threshold when VPF is set to fixed mode.

The operating threshold is expressed in units from 0V to the rated output voltage on a scale of 0-4000. Please note that this is not specified by the rate of decline like the threshold value in tracking mode.

	MIN		MAX		INITIAL	
	[%]	Register value	[%]	Register value	[%]	Register value
VPF fixed threshold	10%	400	120%	4800	90%	3600

<Example> Case where a rated 24V output power supply is used at 19.2V (80%)

If the VPF fixed threshold is set to 70%, 16.8V (70%) will be the VPF signal threshold.

Even if the output voltage is changed to 24V (100%), the VPF signal threshold will not change and will remain at 16.8V (70%).

7.2.23 CPF tracking threshold

Register name	Data type	Address	Size	Non-Volatile
CPF tracking threshold	Holding	540 (0x021C)	1	Yes

This register is used to configure the operating threshold when CPF is set to tracking mode. The operating threshold is expressed as a percentage decrease from the CC target. The rate of decline is expressed in units of 0-4000 scale from 0A to the maximum output current.

	MIN		MAX		INITIAL	
	[%]	Register value	[%]	Register value	[%]	Register value
CPF tracking threshold	5%	200	30%	1200	10%	400

7.2.24 CPF fixed threshold

Register name	Data type	Address	Size	Non-Volatile
CPF fixed threshold	Holding	541 (0x021D)	1	Yes

This register is used to configure the operating threshold when CPF is set to fixed mode. The operating threshold is expressed in units from 0A to the maximum output current on a scale of 0-4000. Please note that this is not specified by the rate of decline like the threshold value in tracking mode.

	MIN		MAX		INITIAL	
	[%]	Register value	[%]	Register value	[%]	Register value
CPF fixed threshold	10%	400	110%	4400	90%	3600

7.2.25 VPF hysteresis

Register name	Data type	Address	Size	Non-Volatile
VPF hysteresis	Holding	550 (0x0226)	1	Yes

This register is used to configure VPF hysteresis.

VPF hysteresis is the amount of hysteresis when the VPF signal stops after being output at the operating threshold. The hysteresis value is expressed in units of 0-4000 scale from 0V to the rated output voltage.

	MIN		MAX		INITIAL	
	[%]	Register value	[%]	Register value	[%]	Register value
VPF hysteresis	1%	40	10%	400	3%	120

<Example> A case where the rated 24V output power supply is used at 24V (100%) and the VPF tracking threshold is set to 400 (10%) in the tracking mode setting.

The VPF threshold will be 21.6V (90%). If VPF hysteresis is set to 3%, the CVPF signal will stop at 22.32V (93%).

7.2.26 CPF hysteresis

Register name	Data type	Address	Size	Non-Volatile
CPF hysteresis	Holding	551 (0x0227)	1	Yes

This register is used to configure CPF hysteresis.

CPF hysteresis is the amount of hysteresis when the CPF signal stops after being output at the operating threshold. The hysteresis value is expressed in units of 0-4000 scale from 0A to the maximum output current.

	MIN		MAX		INITIAL	
	[%]	Register value	[%]	Register value	[%]	Register value
CPF hysteresis	1%	40	10%	400	3%	120

7.2.27 Terminal output control 1

Register name	Data type	Address	Size	Non-Volatile
Terminal output control 1	Holding	590 (0x024E)	1	Yes

This register is used to configure the operation of VPF terminal and CPF terminal when function of the terminal is set to "Terminal output control 1".

The function of VPF terminal and CPF terminal can be changed. (7.2.16, 7.2.17)

If the function is set to "Terminal output control 1", VPF terminal and CPF terminal is opened or shorted according to the value of this register.

MIN	MAX	DATA	INITIAL
0	1	0 : Short (Low) 1 : Open (High)	0

7.2.28 Terminal output control 2

Register name	Data type	Address	Size	Non-Volatile
Terminal output control 2	Holding	591 (0x024F)	1	Yes

This register is used to configure the operation of VPF terminal and CPF terminal when function of the terminal is set to "Terminal output control 2".

The function of VPF terminal and CPF terminal can be changed. (7.2.16, 7.2.17)

If the function is set to "Terminal output control 2", VPF terminal and CPF terminal is opened or shorted according to the value of this register.

MIN	MAX	DATA	INITIAL
0	1	0 : Short (Low) 1 : Open (High)	0

7.2.29 Server Address

Register name	Data type	Address	Size	Non-Volatile
Server Address	Holding	700 (0x02BC)	1	Yes

This register is used to configure Server Address.

The power supply works as a Modbus-RTU server. It is necessary to ensure that there are no duplicate server addresses on the same bus line. This register allows you to change the server address.

NOTE: If you change the server address, it will not be applied immediately. To enable the changed value, restart communication using the Modbus-RTU diagnostic code (FC:0x08).

If communication is not restarted, the timing at which the changed settings become effective varies depending on the method of power supply to HWS3000x. If power is being supplied from the input terminal, the changed settings will be enabled by cutting off the input and turning it on again after 3 minutes or more. If power is supplied from the PWR terminal without applying voltage to the input terminal, the changed settings will be enabled by turning off the power supply from the PWR terminal and then turning it on again after 3 seconds or more have elapsed.

MIN	MAX	DATA	INITIAL
1	247	Server Address	1

7.2.30 Baud Rate

Register name	Data type	Address	Size	Non-Volatile
Baud Rate	Holding	701 (0x02BD)	1	Yes

This register is used to configure Baud rate when performing Modbus-RTU communication.

NOTE: If you change the baud rate, it will not be applied immediately. To enable the changed value, restart communication using the Modbus-RTU diagnostic code (FC:0x08).

If communication is not restarted, the timing at which the changed settings become effective varies depending on the method of power supply to HWS3000x. If power is being supplied from the input terminal, the changed settings will be enabled by cutting off the input and turning it on again after 3 minutes or more. If power is supplied from the PWR terminal without applying voltage to the input terminal, the changed settings will be enabled by turning off the power supply from the PWR terminal and then turning it on again after 3 seconds or more have elapsed.

MIN	MAX	DATA	INITIAL
0	6	0 : 2400 bps 1 : 4800 bps 2 : 9600 bps 3 : 19200 bps 4 : 38400 bps 5 : 57600 bps 6 : 115200 bps	6

7.2.31 Parity & Stop Bit

Register name	Data type	Address	Size	Non-Volatile
Parity & Stop Bit	Holding	702 (0x02BE)	1	Yes

This register is used to configure Parity and Stop bit settings for Modbus-RTU communication. A response to a request to this register will be returned with the settings before the settings were changed.

NOTE: If you change the parity and stop bit settings, it will not be applied immediately. To enable the changed value, restart communication using the Modbus-RTU diagnostic code (FC:0x08).

If communication is not restarted, the timing at which the changed settings become effective varies depending on the method of power supply to HWS3000x. If power is being supplied from the input terminal, the changed settings will be enabled by cutting off the input and turning it on again after 3 minutes or more. If power is supplied from the PWR terminal without applying voltage to the input terminal, the changed settings will be enabled by turning off the power supply from the PWR terminal and then turning it on again after 3 seconds or more have elapsed.

MIN	MAX	DATA	INITIAL
0	2	0 : Parity : None / Stop : 2 bit 1 : Parity : Odd / Stop : 1 bit 2 : Parity : Even / Stop : 1 bit	2

7.2.32 Response transmission waiting time

Register name	Data type	Address	Size	Non-Volatile
Response transmission waiting time	Holding	703 (0x02BF)	1	Yes

This register is used to configure Response transmission waiting time.

If other devices are connected on the same bus line as HWS3000x, frame separation may not be recognized properly depending on the compatibility of the devices. If this is the case, you may be able to resolve the issue by increasing the wait time for HWS3000x responses. See Figure 5-1 Unicast for the response transmission waiting time.

NOTE: Changes made using this register will be applied immediately, and responses from this register will also be returned with a delay of the set time.

NOTE: Be careful not to let the client time out.

MIN	MAX	DATA	INITIAL
0	99	Response transmission waiting time [ms]	20

7.2.33 Communication settings forced default

Register name	Data type	Address	Size	Non-Volatile
Communication settings forced default	Holding	720 (0x02D0)	1	No

This register is used to set communication settings to default.

The communication settings that are set as default are the items that can be set using the communication registers below. Refer to each register for the default value.

- 7.2.29 Server Address
- 7.2.30 Baud Rate
- 7.2.31 Parity & Stop Bit
- 7.2.32 Response transmission waiting time

NOTE: To execute this register, the baud rate setting and parity/stop bit setting must match those of the HWS3000x. If you don't know the configured communication settings, broadcast this register using all baud rate, parity and stop bit combinations. Our GUI has dedicated buttons to perform the above operations.

MIN	MAX	DATA	INITIAL
0	1	0 : Ignore 1 : Execute	-

7.2.34 Server address consecutive assignment

Register name	Data type	Address	Size	Non-Volatile
Server address consecutive assignment	Holding	721 (0x02D1)	1	No

This register is used to set the server address, which is common at the time of shipment from our company, to avoid duplication when multiple HWS3000x units are connected on the same RS-485 communication bus.

Use this register according to the following procedure.

<1 connection>

Connect multiple HWS3000x in a daisy chain including RS-485 wiring using CN41 and CN42 connectors. Make sure that the A/I terminal (5pin) of CN41 is connected to the A/O terminal (5pin) of CN42. Please refer to Figure 3-2 Actual wiring for details.

<2 Initialization>

Send 7.2.33 Communication settings forced default by broadcast and initialize the communication settings. The communication settings at this time (baud rate and parity) must be the values set in HWS3000x. If you don't know the configured communication settings, broadcast 7.2.33 Communication settings forced default using all baud rate, parity and stop bit combinations.

<3 Server address settings>

Set any value you want to set as the server address in this register and send it by broadcast. However, the value set in this register must be other than 1. After that, wait for an interval of 100ms or more, set a different server address from the previous one, and send the broadcast again. By repeating this for each HWS3000x, unique server addresses will be set in order from HWS3000x closest to the client.

MIN	MAX	DATA	INITIAL
2	247	Server Address	-

NOTE: This function uses broadcast communication, so no response is generated from the server. After using this register, perform unicast communication and confirm that the server address has been assigned correctly.

7.2.35 Scratch pad 1

Register name	Data type	Address	Size	Non-Volatile
Scratch pad 1	Holding	800 (0x0320)	1	Yes

This register is used by customer to store data freely.

Since the value set in this register is saved in non-volatile memory, the data is retained even after input is shut off.

This register consists of a continuous 16 bit x 15 area and can store data of up to 30 characters in terms of ASCII characters. This register is open for the host device, and HWS3000x does not care about register contents..

For register access, any data length from 1 word to register block size length can be specified. Due to the Modbus-RTU protocol, access is in 16 bit units, so when saving odd number byte data, padding ('0x00' recommended) is required to make it an even number byte.

7.2.36 Scratch pad 2

Register name	Data type	Address	Size	Non-Volatile
Scratch pad 2	Holding	820 (0x0334)	1	Yes

This register is used by customer to store data freely.

Same as Scratch pad 1. Please refer to 7.2.35.

7.2.37 Factory reset

Register name	Data type	Address	Size	Non-Volatile
Factory reset	Holding	900 (0x0384)	1	No

Each Holding register setting value except Server Address, Baud Rate, Parity & Stop Bit, and Response transmission waiting time can be returned to the factory settings. Please note that power output may start or stop depending on the status of the +R/-R terminals.

MIN	MAX	DATA	INITIAL
0	1	0 : Ignore 1 : Execute	-

7.2.38 Log read reset

Register name	Data type	Address	Size	Non-Volatile
Log read reset	Holding	910 (0x0384)	1	No

This register is used to reset log reference destination to the latest log.
Please use the log read register of 7.1.18 or 7.1.19 to read log.

MIN	MAX	DATA	INITIAL
0	1	0 : Ignore 1 : Execute	-

8 NOTE

- Contents of the communication manual may be changed without a prior notice. Refer to latest communication manual.
- Reproduction or reprinting the communication manual or its portion is forbidden without our permission.
- The stability of communication depends on the environment. Thoroughly evaluate it with the final device.