

PFE1500FB-48-xxx-R

Evaluation Report



Table of Contents

1.	EVALUATION METHOD	3
1.1.	Test / Measurement Circuits	3
1.1.1.	Steady State Test Measurement Circuit	3
1.1.2.	Dynamic, Protection and Output Ripple and Noise Measurement Circuit.....	3
1.1.3.	Inrush Current Measurement Circuit.....	4
1.1.4.	Leakage Current Measurement Circuit.....	4
1.1.5.	Electromagnetic Interference Test Setup	4
2.	CHARACTERISTICS.....	12
2.1	Steady State Data (Refer to Section 1.1.1 For Test Setup)	12
2.1.1	Regulation – Line, Load.....	12
2.1.2	Efficiency vs. Output Current (60 Hz)	19
2.1.3	Power Factor (PF) vs. Input Voltage (60 Hz).....	20
2.1.4	Output behavior with input line sweep (60 Hz)	21
2.2	Over Voltage Protection (OVP) Characteristics (Refer to Section 1.1.2 for Test Setup).....	26
2.3	Output Rise and Fall Characteristics with AC Turn On	26
2.4	Hold Up Time Characteristic	29
2.5	Dynamic Line Response (60 Hz).....	30
2.6	Dynamic Load Response	31
2.7	Input Current Waveform	32
2.8	Input Current Harmonics	33
2.9	Input Inrush Current	34
2.10	Brownout Data.....	36
2.11	Output Ripple and Noise	37

1. EVALUATION METHOD

1.1. Test / Measurement Circuits

1.1.1. Steady State Test Measurement Circuit

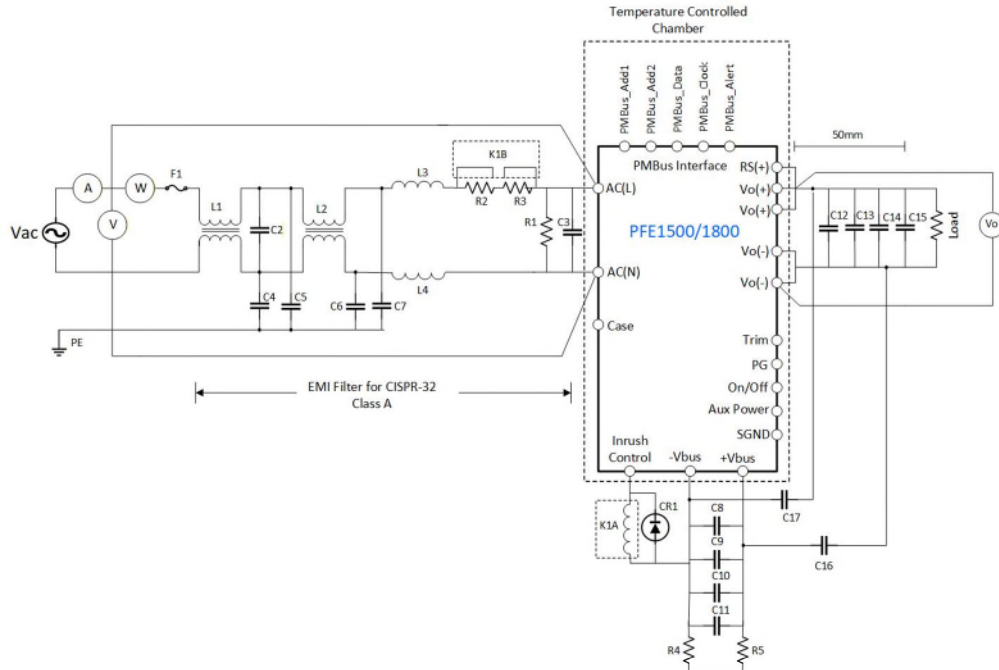

1.1.2. Dynamic, Protection and Output Ripple and Noise Measurement Circuit

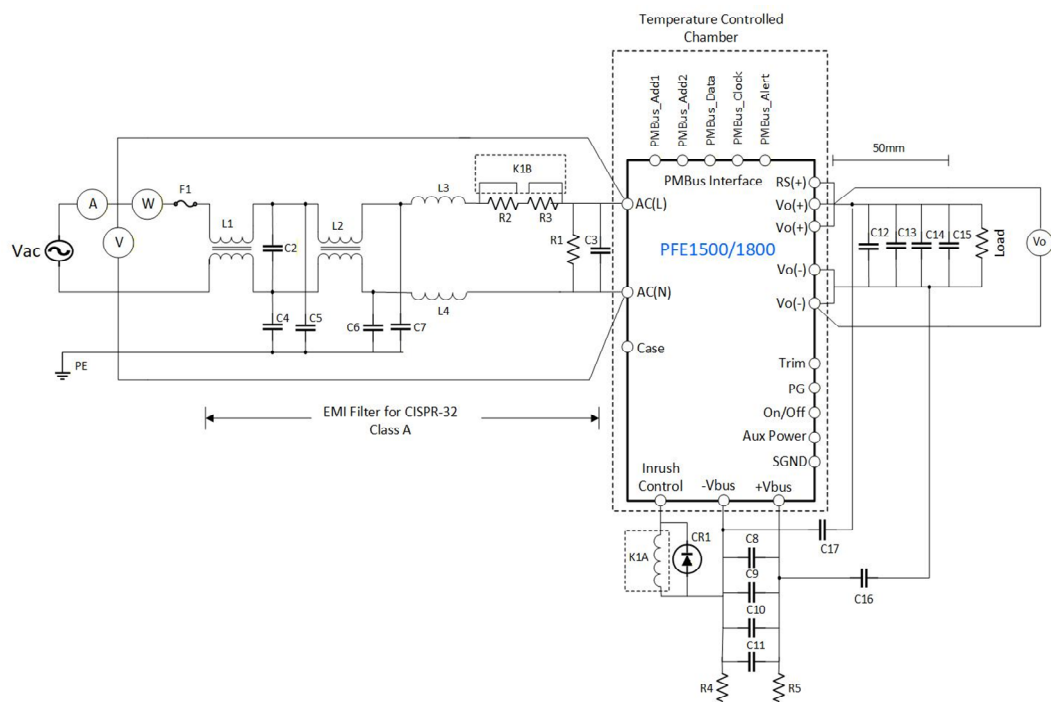

1.1.3. Inrush Current Measurement Circuit

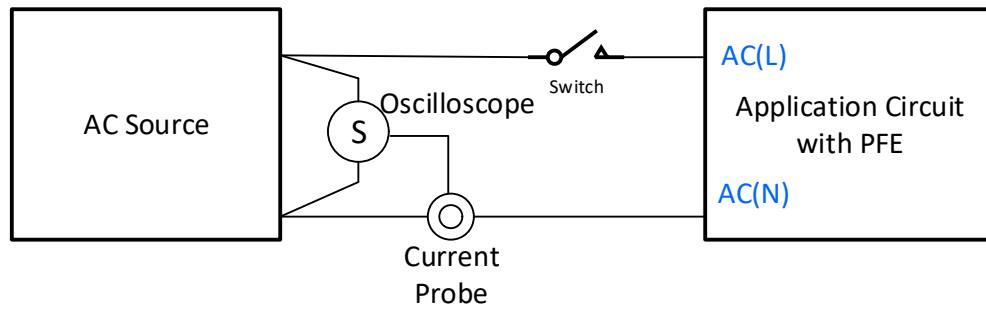

1.1.4. Leakage Current Measurement Circuit

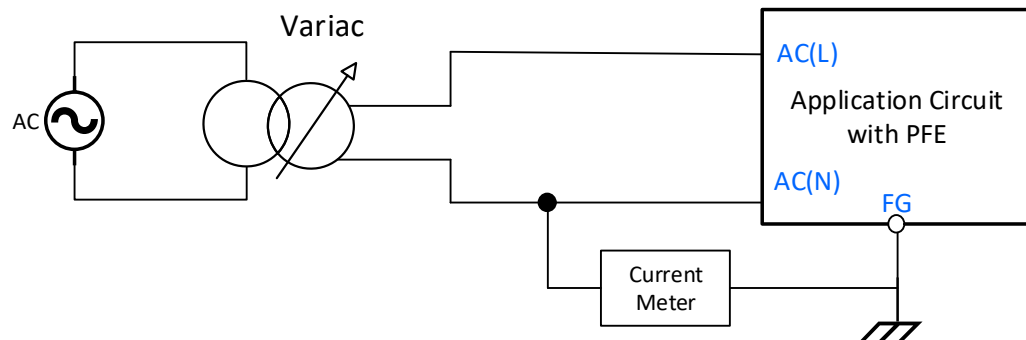

1.1.5. Electromagnetic Interference Test Setup

1.1.5.1. Conducted EMI

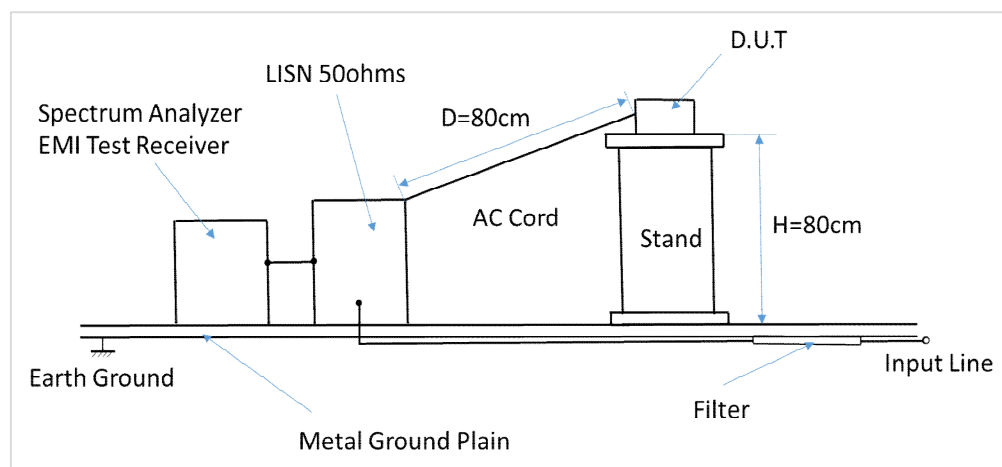

1.1.5.2. Radiated EMI

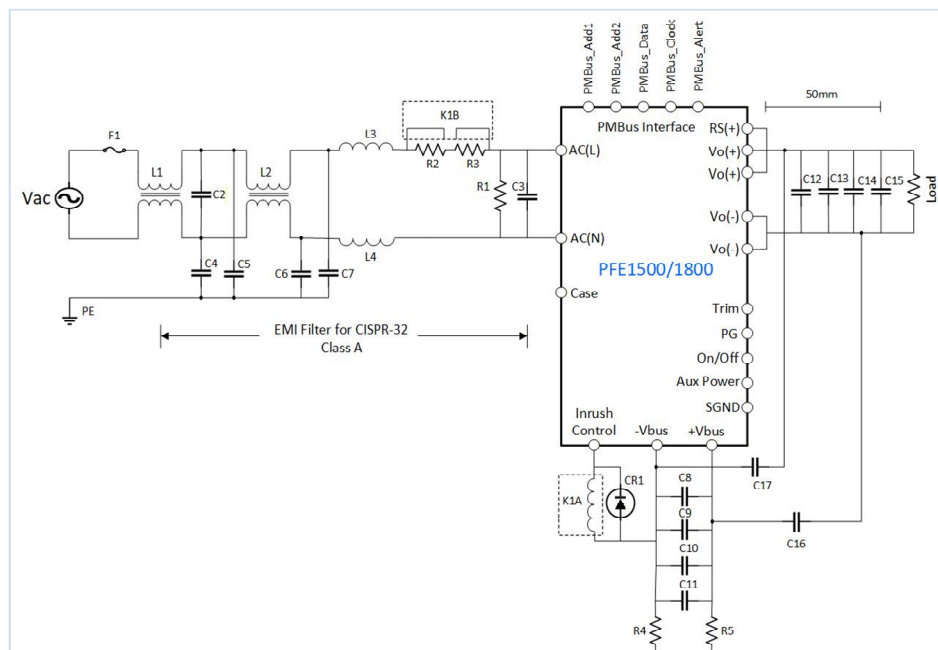
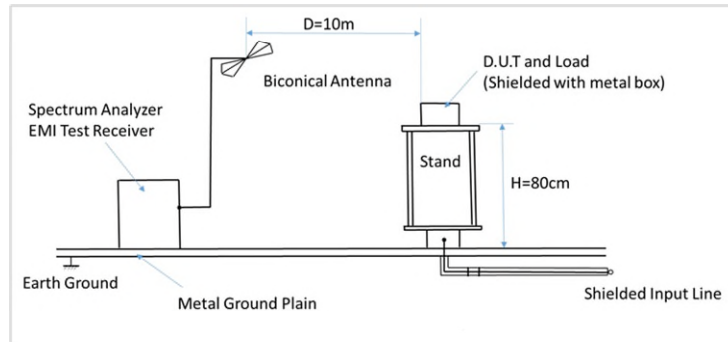

Reference Designator	Description	Reference Designator	Description
C2	0.47 μ F Film Capacitor	C3	2x2.2 μ F Film Capacitor
C4, C5, C6, C7	4700pF Ceramic Capacitor	C15	0.1 μ F ceramic capacitor
C16, C17	7500pF ceramic capacitor	CR1	CRH01, 200V, 1A Diode
L1	1mH	R2, R3	10 Ω 5W
L2	1.3mH	C12, C13	560 μ F electrolytic capacitor
L3, L4	27 μ H	C14	8x4.7 μ F Ceramic Capacitor
R1, R4, R5	470 k Ω , 2 W	C8, C9, C10, C11	470 μ F Electrolytic Capacitor
K1	1 Form A relay with 16A, 277VAC, power rating: 12VDC, 16.7mA, 200mW, High Sensitivity	F1	20A, 280V, Fast Blow

1.1.5.3. Conducted EMI Results

Line. 120Vac, Iout = 24A, 60 Hz

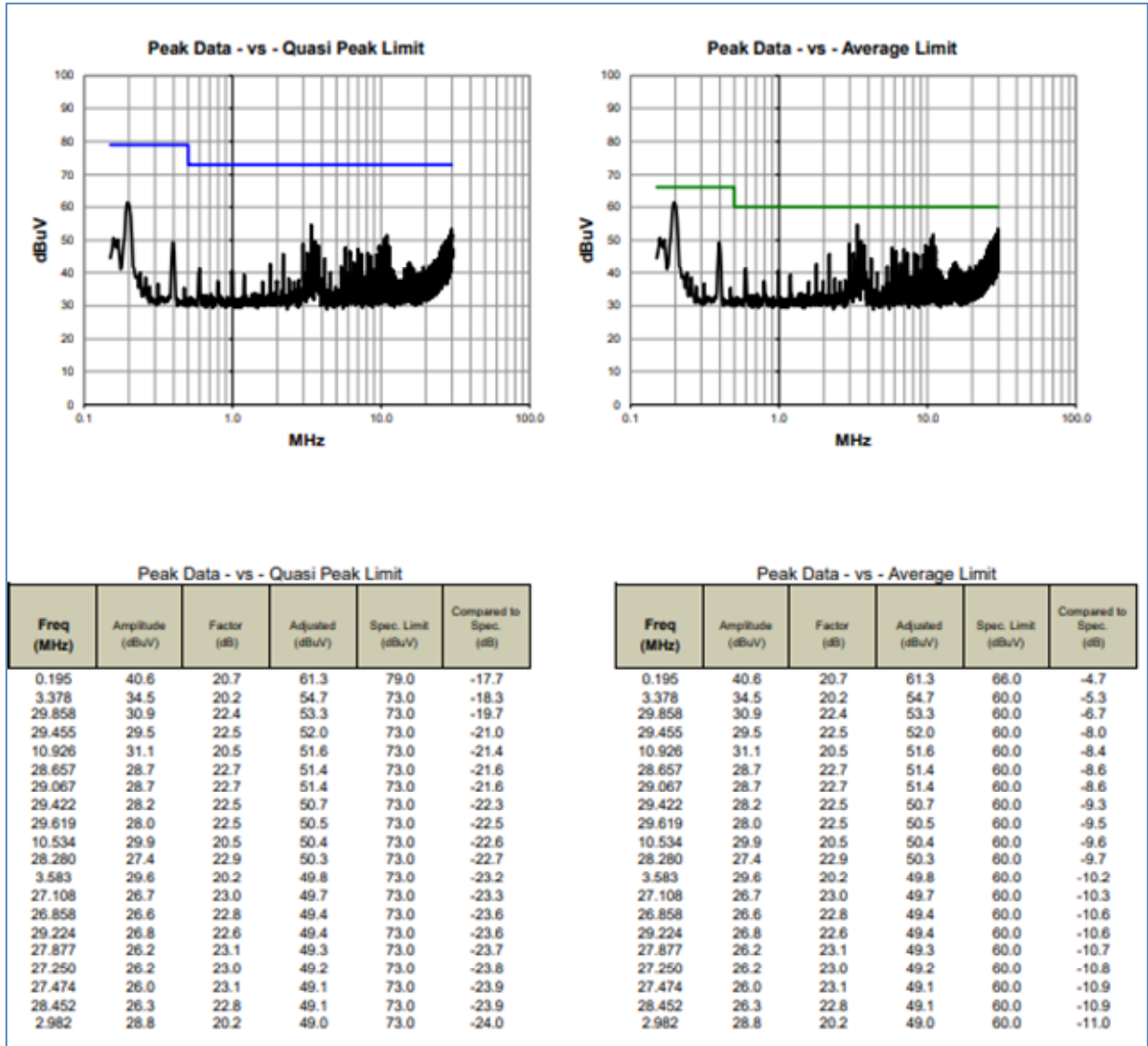

Neutral. 120Vac, Iout = 24A, 60 Hz

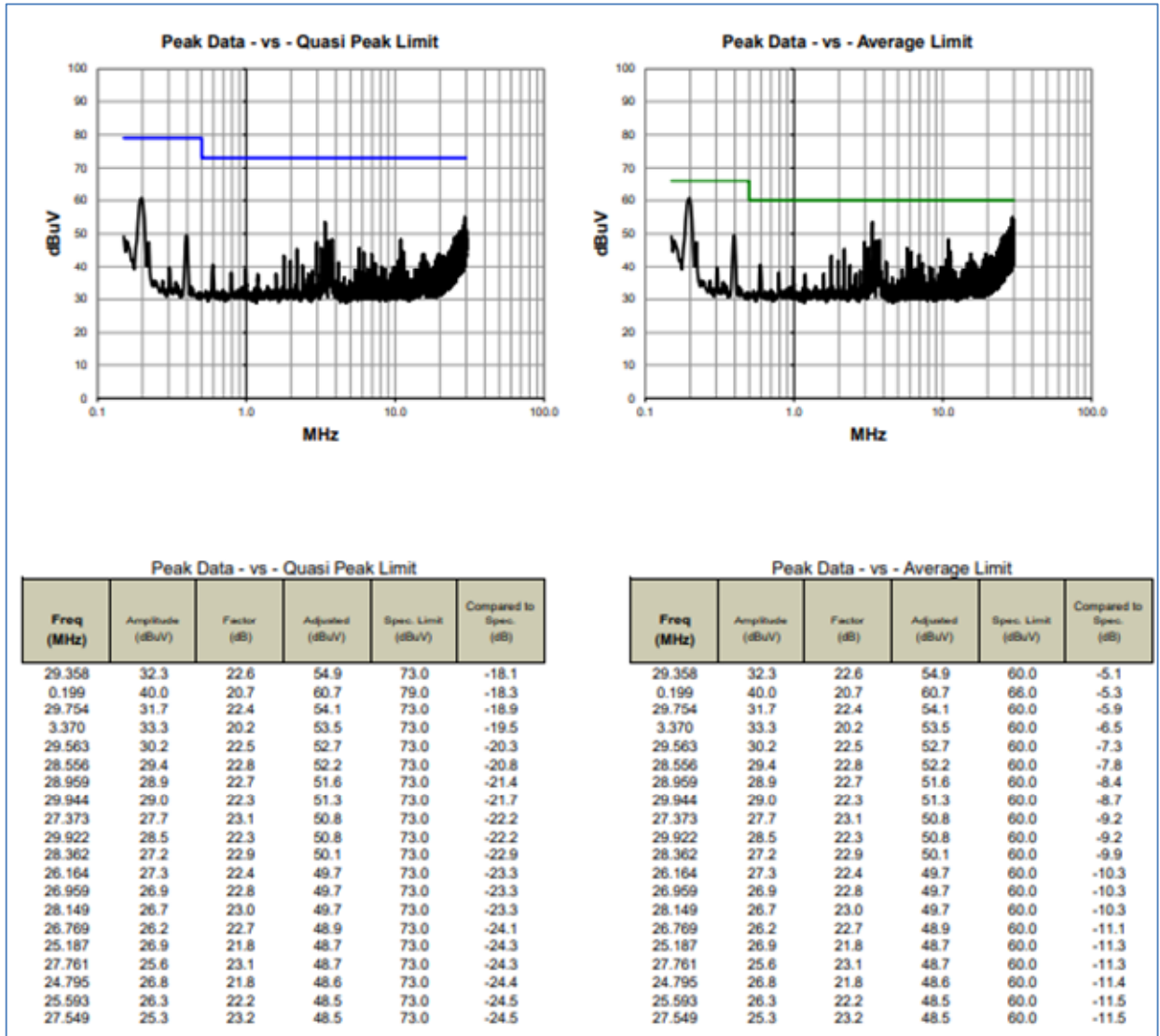

Line. 230Vac, Iout = 24A, 50 Hz

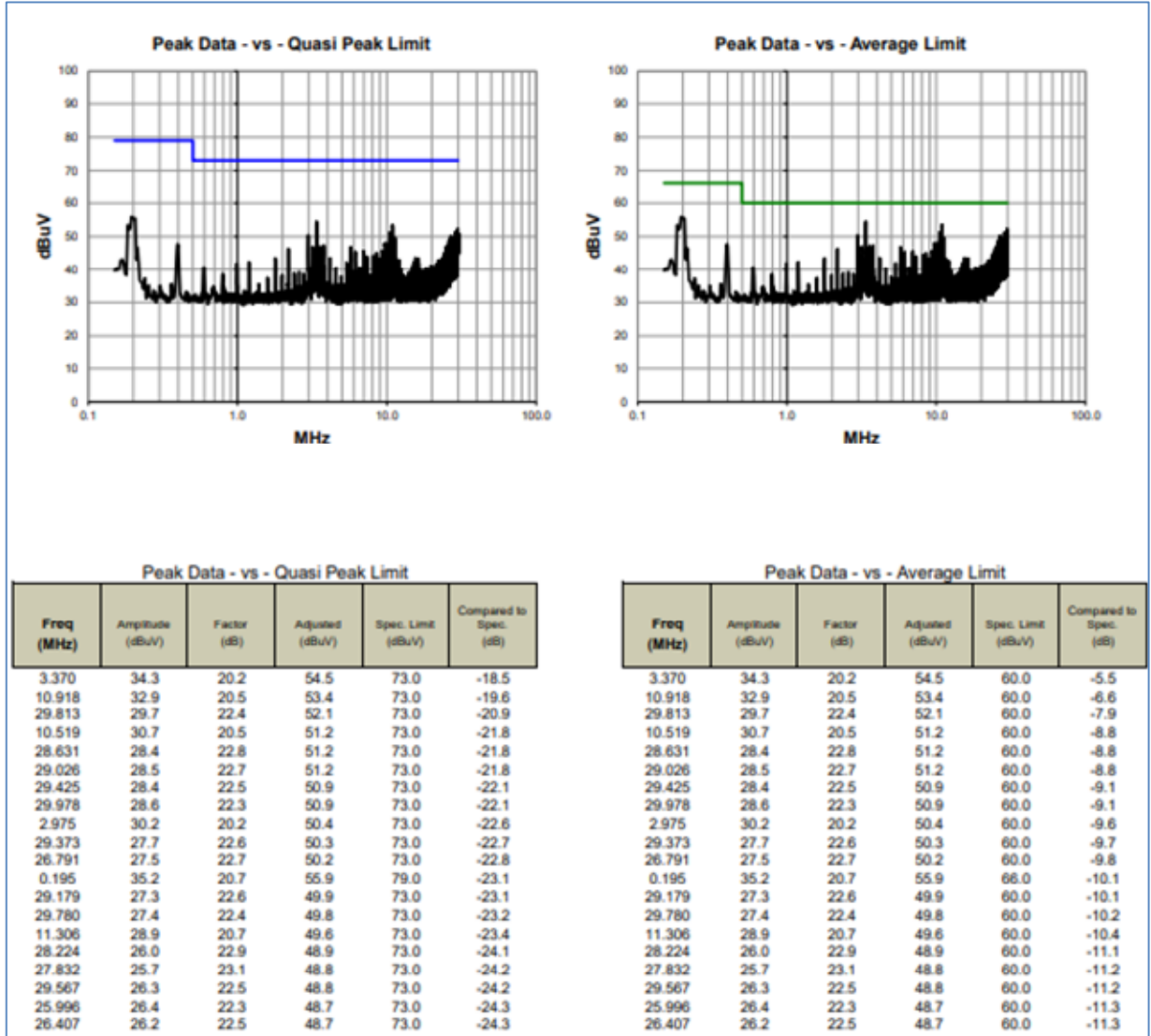

Neutral, 230Vac, Iout = 24A, 50 Hz

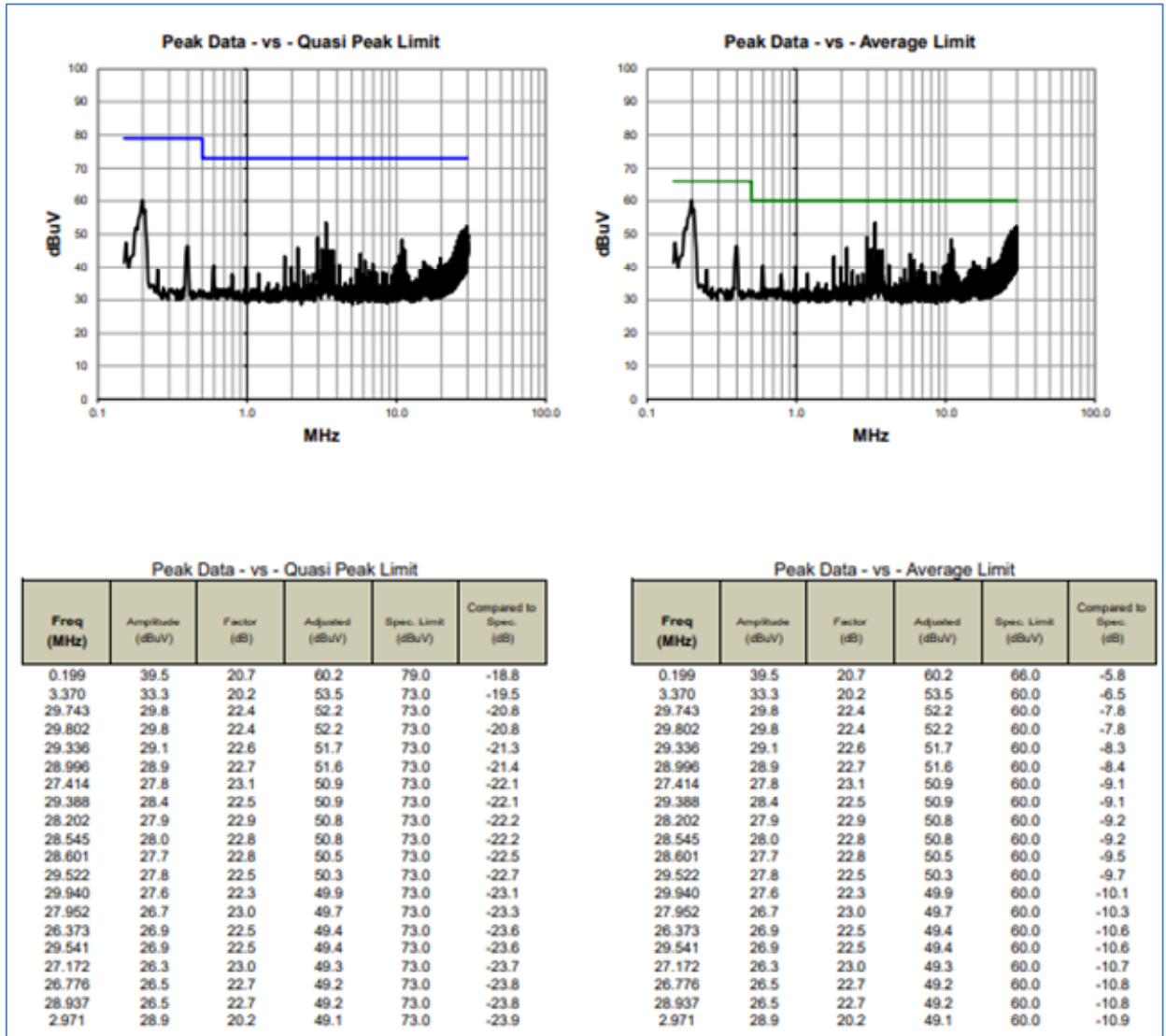

1.1.5.4. Radiated EMI Results

230Vac, Iout = 28A, 50 Hz

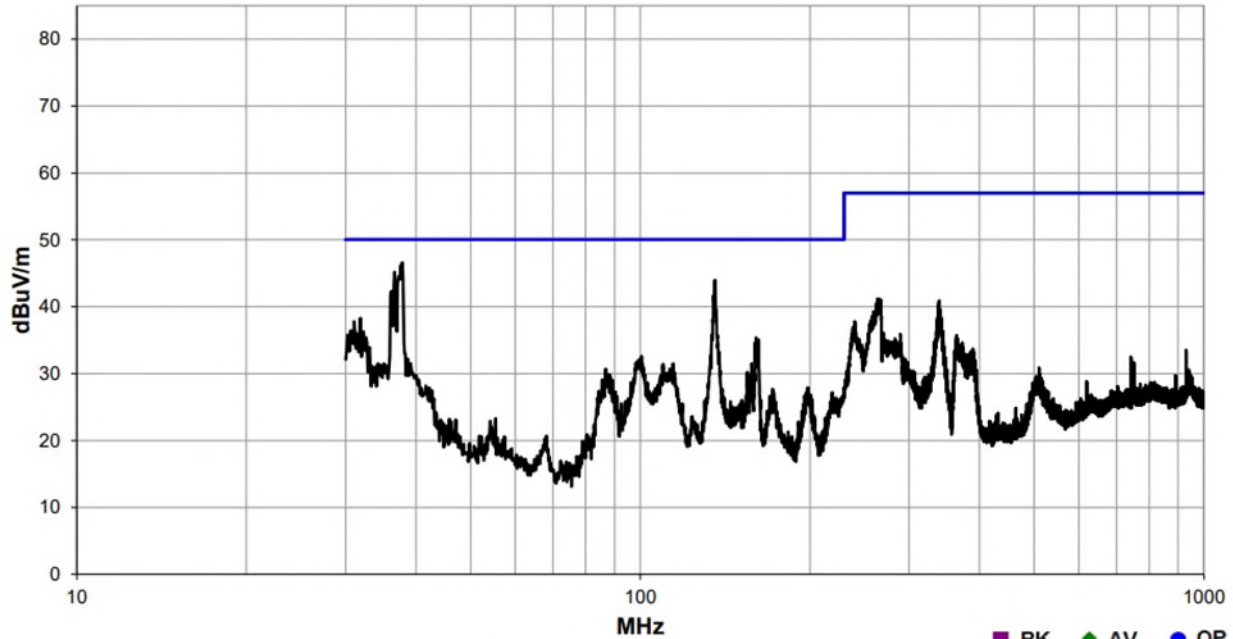

Freq (MHz)	Amplitude (dBuV)	Preamp (dB)	Antenna Height (meters)	Transducer (dB/m)	Cable (dB)	External Attenuation (dB)	Polarity/Transducer Type	Detector	Distance Adjustment (dB)	Adjusted (dBuV/m)	Spec. Limit (dBuV/m)	Compared to Spec. (dB)
37.816	69.0	38.1	2.8	14.7	1.0	0.0	Vert	PK	0.0	46.6	50.0	-3.4
36.632	67.0	38.1	2.8	15.3	1.0	0.0	Vert	PK	0.0	45.2	50.0	-4.8
135.751	68.4	38.0	1.0	12.0	1.6	0.0	Vert	PK	0.0	44.0	50.0	-6.0
36.158	63.8	38.1	2.8	15.5	1.1	0.0	Vert	PK	0.0	42.3	50.0	-7.7
135.751	63.3	38.0	3.8	12.0	1.6	0.0	Horz	PK	0.0	38.9	50.0	-11.1
31.895	56.8	38.1	1.0	17.6	2.0	0.0	Vert	PK	0.0	38.3	50.0	-11.7
31.066	55.7	38.1	1.0	18.1	2.1	0.0	Vert	PK	0.0	37.8	50.0	-12.2
32.250	55.0	38.1	1.0	17.5	1.9	0.0	Vert	PK	0.0	36.3	50.0	-13.7
160.383	57.5	38.1	1.5	14.2	1.8	0.0	Horz	PK	0.0	35.4	50.0	-14.6
162.041	57.6	38.1	1.0	13.8	1.8	0.0	Horz	PK	0.0	35.1	50.0	-14.9
160.028	56.7	38.1	2.0	14.3	1.8	0.0	Horz	PK	0.0	34.7	50.0	-15.3
264.003	59.6	38.2	1.5	17.5	2.3	0.0	Vert	PK	0.0	41.2	57.0	-15.8
267.319	59.5	38.3	2.0	17.5	2.3	0.0	Horz	PK	0.0	41.0	57.0	-16.0
339.202	58.5	38.3	1.0	18.2	2.5	0.0	Horz	PK	0.0	40.9	57.0	-16.1
33.079	53.3	38.1	1.0	17.0	1.7	0.0	Vert	PK	0.0	33.9	50.0	-16.1
100.462	57.4	38.0	2.8	11.7	1.5	0.0	Horz	PK	0.0	32.6	50.0	-17.4
114.317	56.1	38.0	2.0	11.9	1.5	0.0	Horz	PK	0.0	31.5	50.0	-18.5
157.660	53.3	38.1	2.8	14.6	1.7	0.0	Horz	PK	0.0	31.5	50.0	-18.5
109.580	55.6	38.0	1.0	12.2	1.5	0.0	Vert	PK	0.0	31.3	50.0	-18.7
109.462	55.4	38.0	2.8	12.2	1.5	0.0	Horz	PK	0.0	31.1	50.0	-18.9

List of Equipment

	EQUIPMENT USED	MANUFACTURER	MODEL NO.
1	OSCILLOSCOPE	LECROY	HDO 4054
2	OSCILLOSCOPE	LECROY	HDO 4054
3	DIGITAL MULTIMETER	KEITHLEY	2110
4	DIGITAL MULTIMETER	KEITHLEY	2110
5	DIFFERENTIAL AMPLIFIER	LECROY	DA1855A
6	DIFFERENTIAL AMPLIFIER	LECROY	DA1855A
7	SHUNT RESISTOR	EMPRO SHUNT	HA20-100
8	TEMP CHAMBER	TENNEY JUNIOR ENVIRONMENTAL	TJR
9	DIFFERENTIAL PROBE	LECROY	A101
10	DIFFERENTIAL PROBE	LECROY	DXG100A
11	DIGITAL POWER METER	YOKOGAWA	WT310
12	SURGE TESTER	TESEQ	NSG 3060A-ANSI
13	DC ELECTRONIC LOAD	CHROMA	63201
14	FREQUENCY ANALYZER	AP INSTRUMENT	300
15	AC POWER SOURCE	CHROMA	6530
16	INJECTION ISOLATOR	RIDLEY ENGINEERING	0.1Hz TO 30MHz
17	WAVEFORM GENERATOR	AGILENT	33120A
18	DC ELECTRONIC LOAD	CHROMA	6334
19	AC CONTROL	SORENSEN	DCS150-20
20	THERMOSTREAM	TEMPTRONIC CORPORATION	ATS-810-M-4
21	CURRENT PROBE	LECROY	AP015
22	CURRENT PROBE	LECROY	CP150

2. CHARACTERISTICS

2.1 Steady State Data (Refer to Section 1.1.1 For Test Setup)

2.1.1 Regulation – Line, Load

a. Line Regulation (60 Hz)

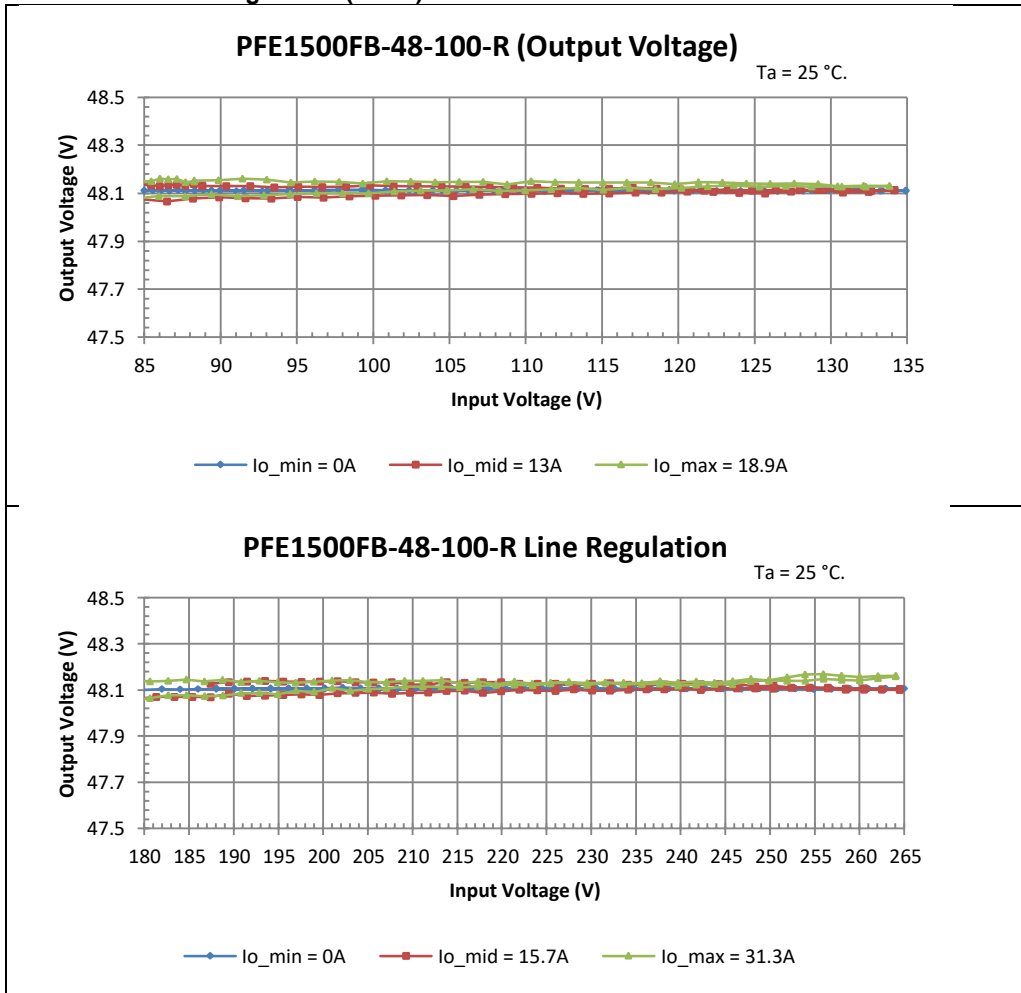

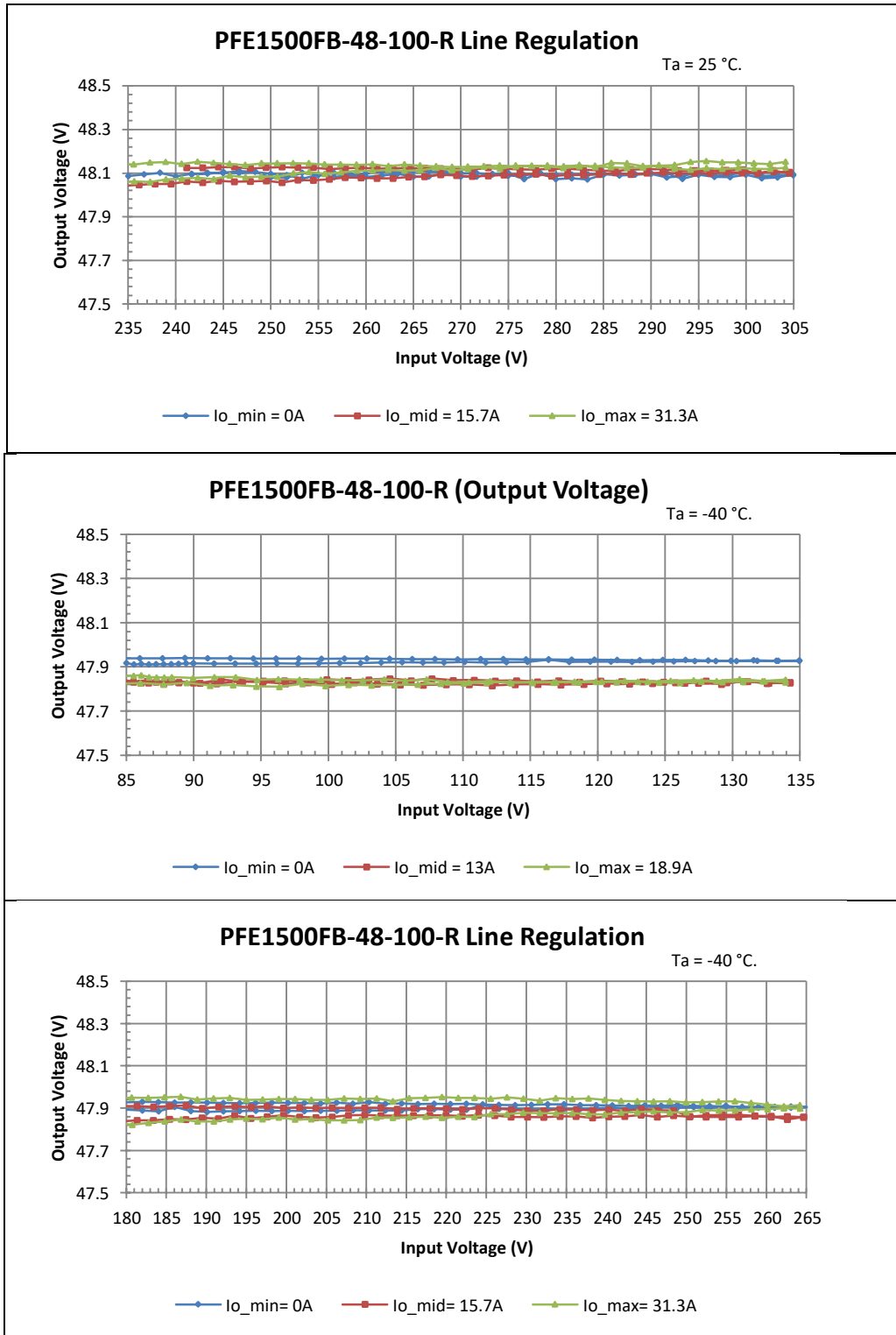

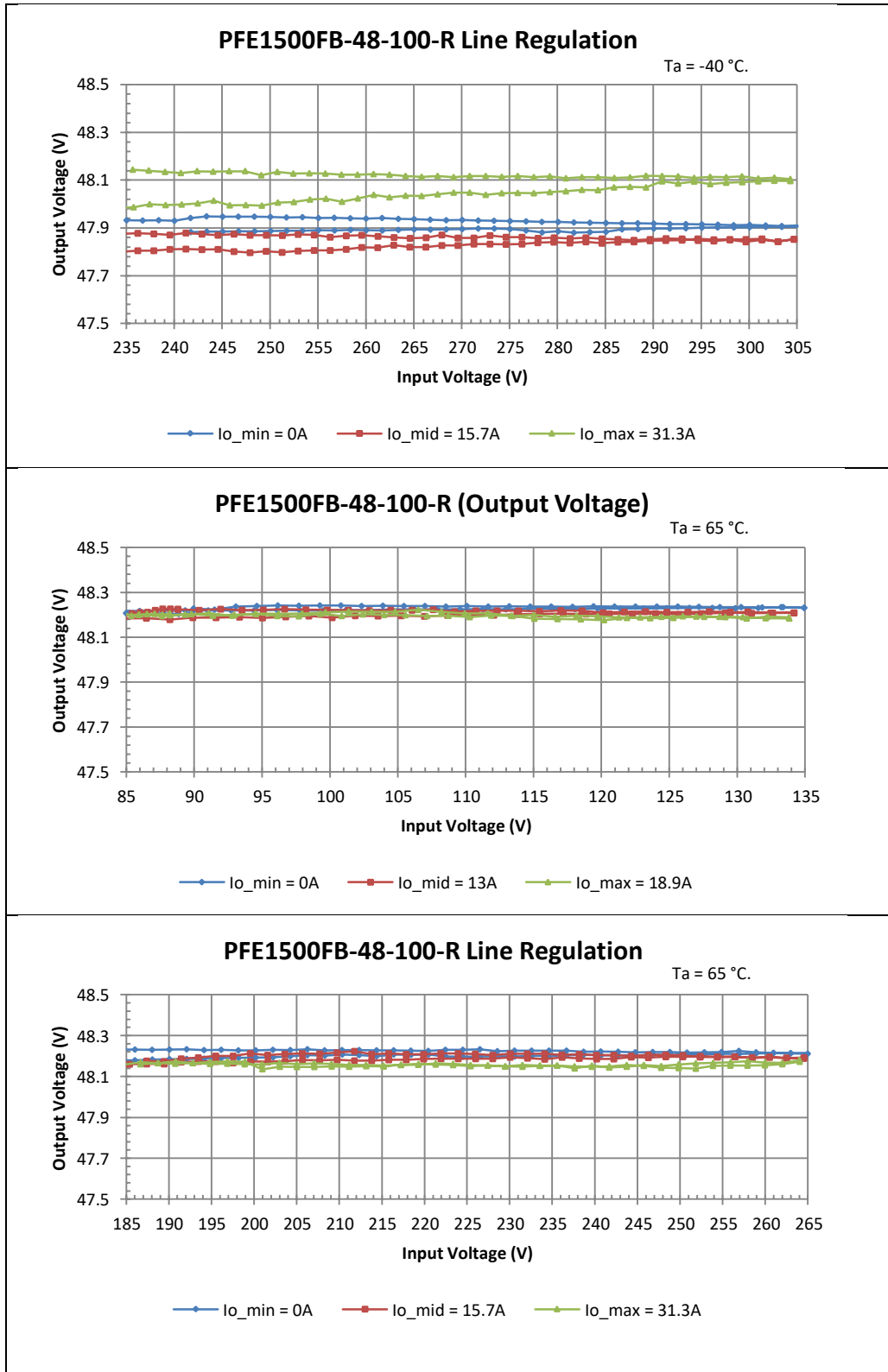

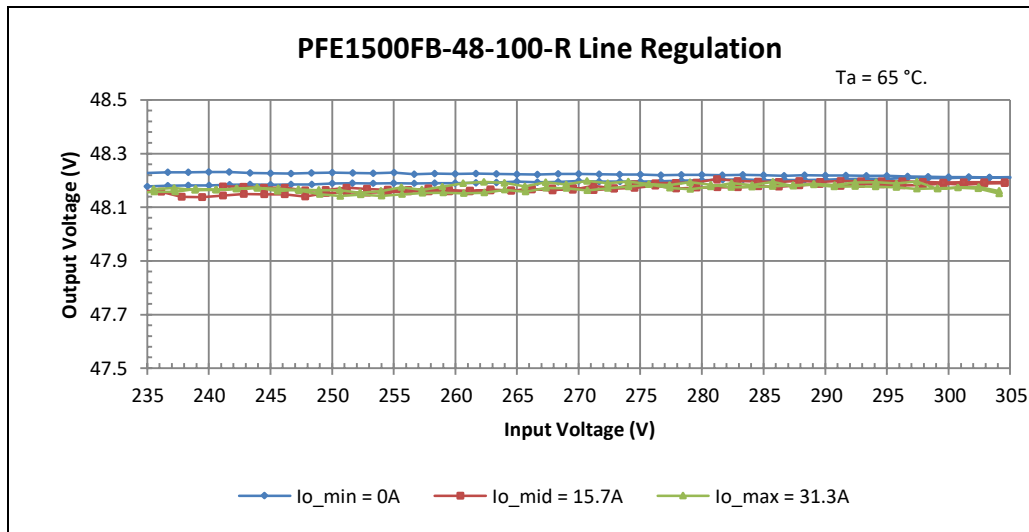

b. Load Regulation (60 Hz)

PFE1500FB-48-100-R Load Regulation

Ta = 25 °C.

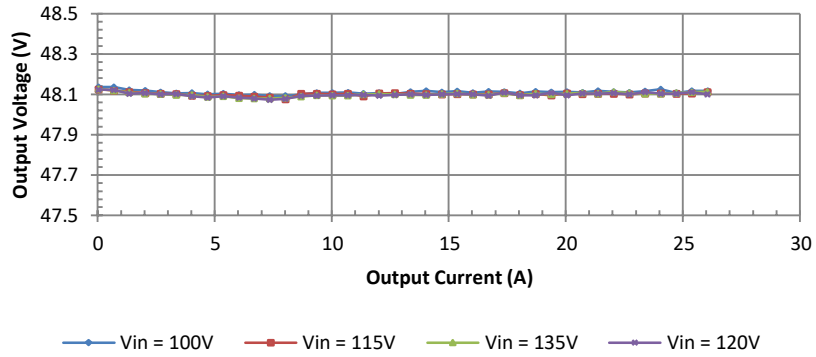

PFE1500FB-48-100-R Load Regulation

Ta = 25 °C.

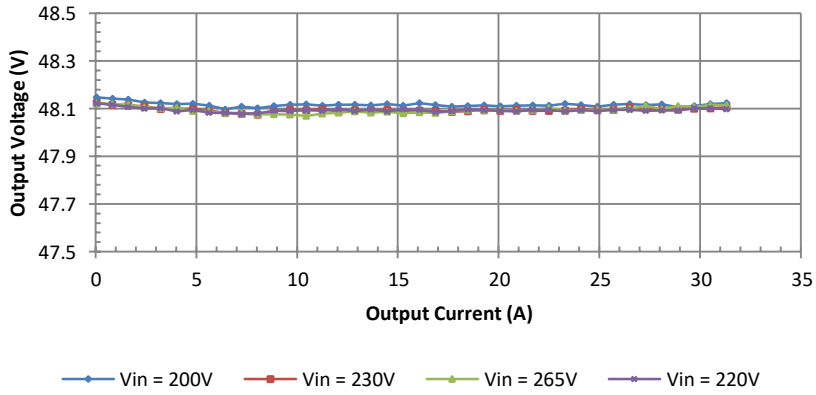

PFE1500FB-48-100-R Load Regulation

Ta = 25 °C.

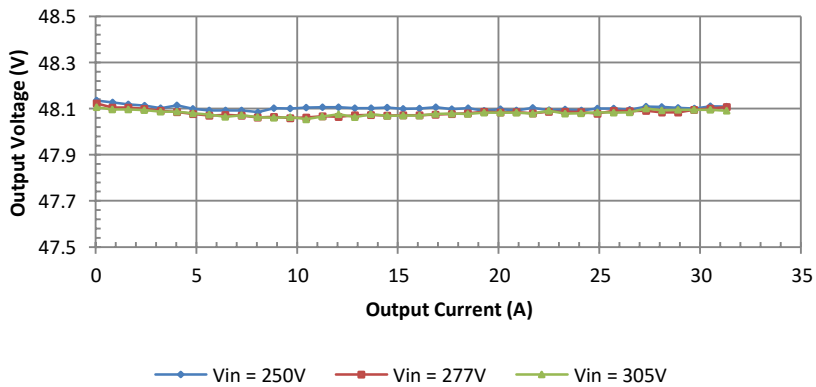

PFE1500FB-48-100-R Load Regulation

Ta = -40 °C.

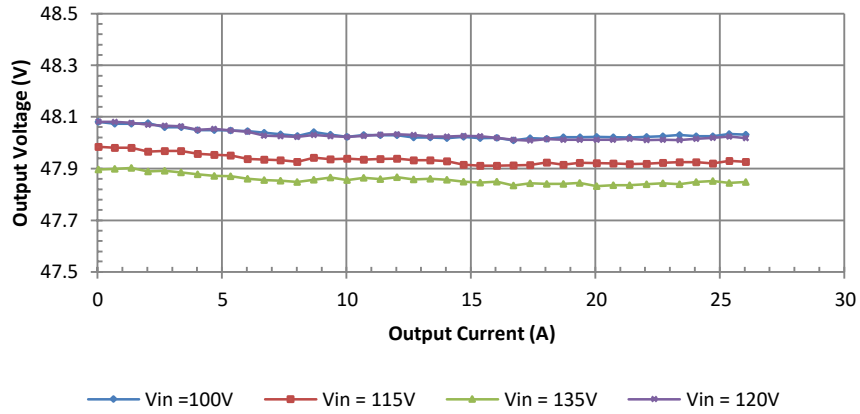

PFE1500FB-48-100-R Load Regulation

Ta = -40 °C.

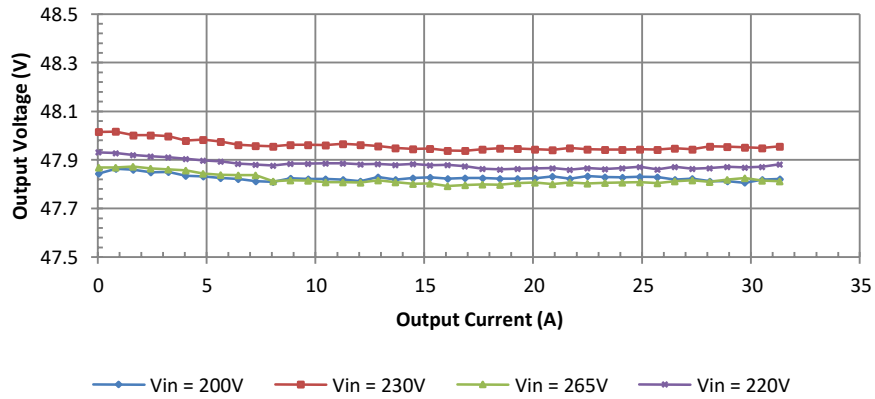

PFE1500FB-48-100-R Load Regulation

Ta = -40 °C.

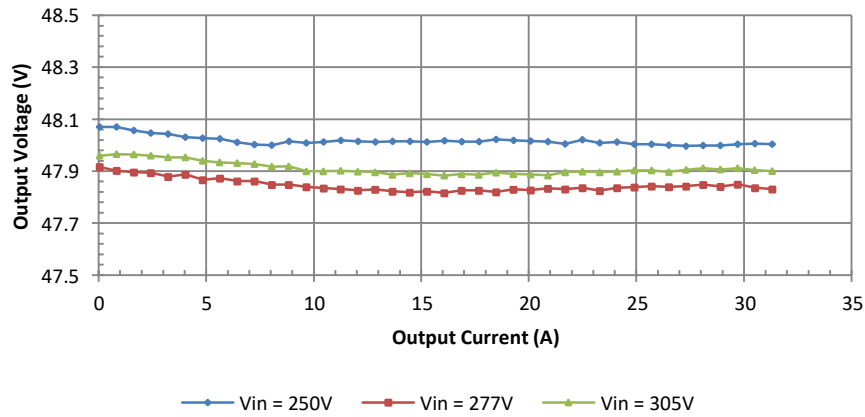

PFE1500FB-48-100-R Load Regulation

Ta = 65 °C.

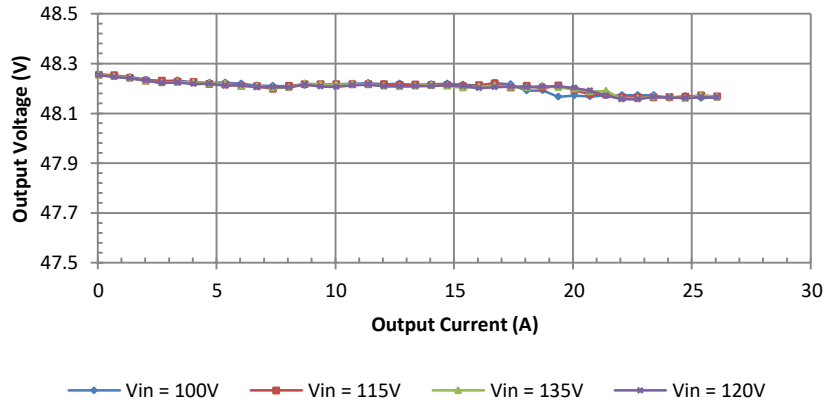

PFE1500FB-48-100-R Load Regulation

Ta = 65 °C.

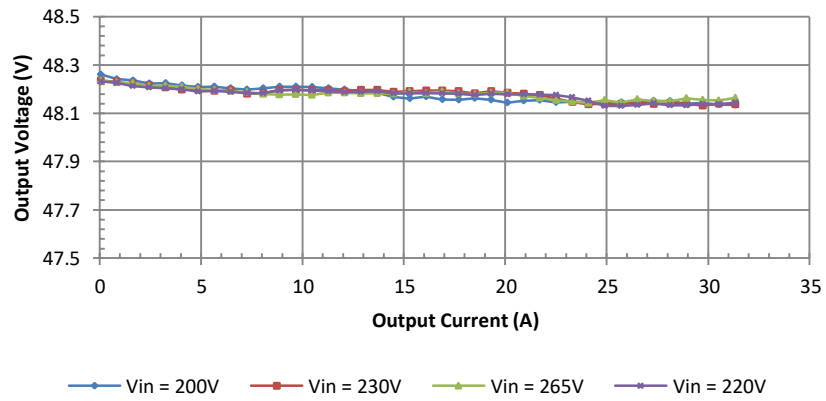

PFE1500FB-48-100-R Load Regulation

Ta = 65 °C.

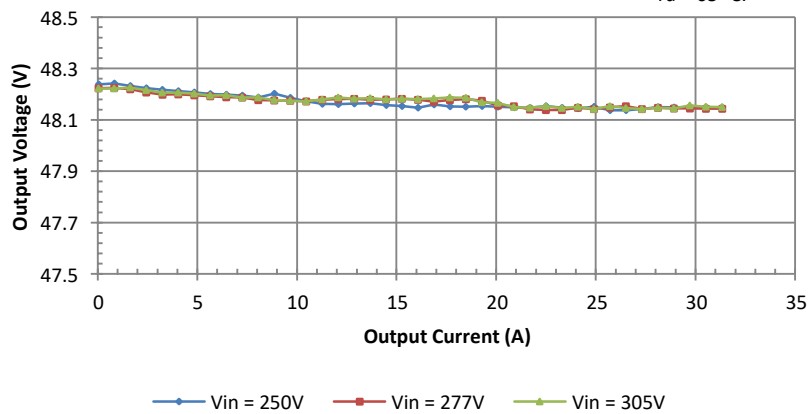

2.1.2 Efficiency vs. Output Current (60 Hz)

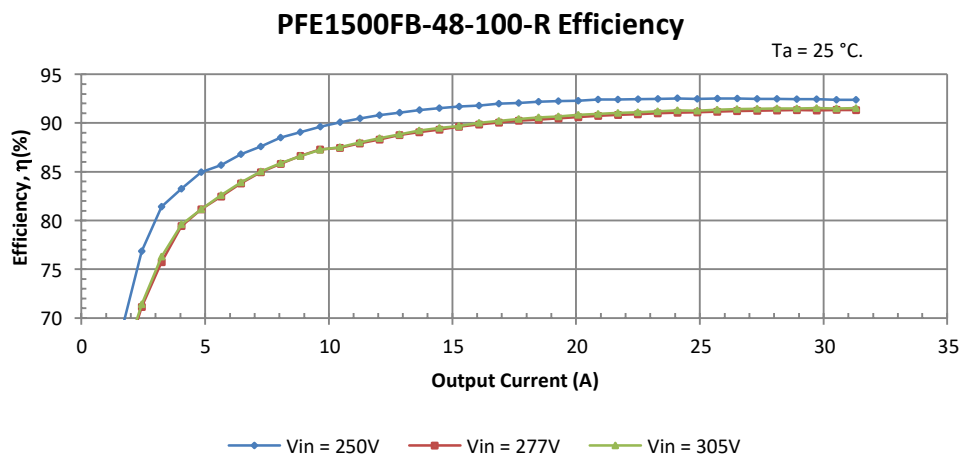
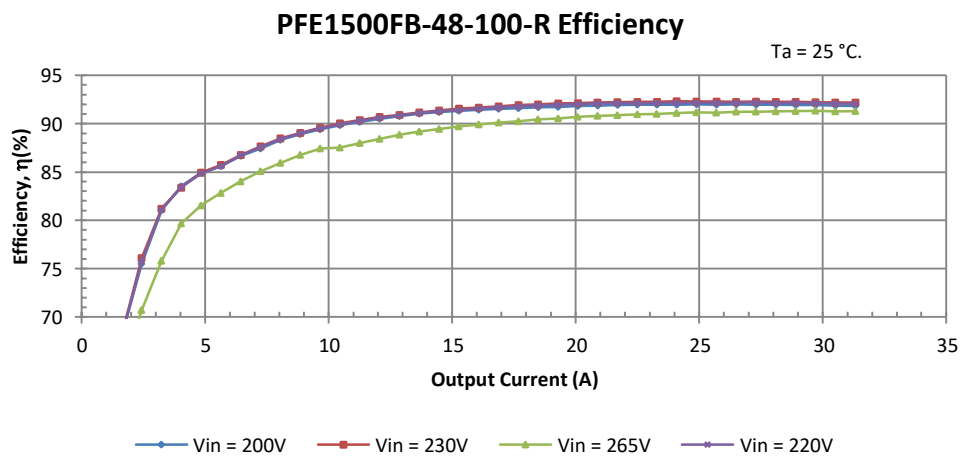
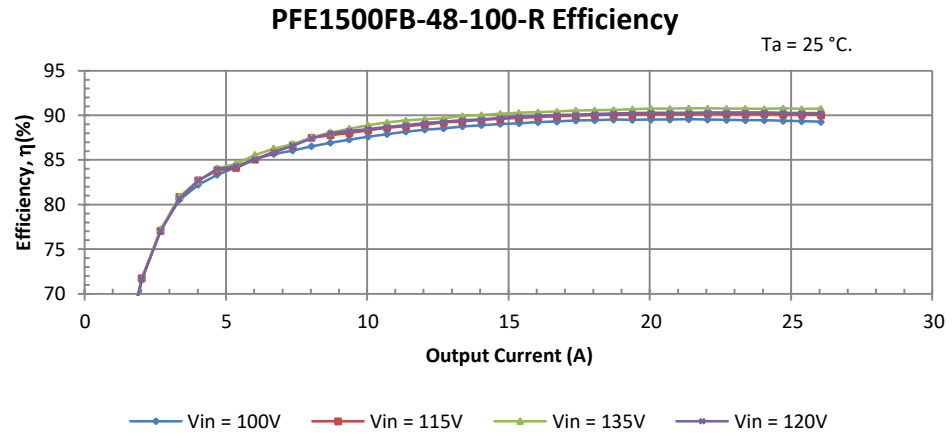

2.1.3 Power Factor (PF) vs. Input Voltage (60 Hz)

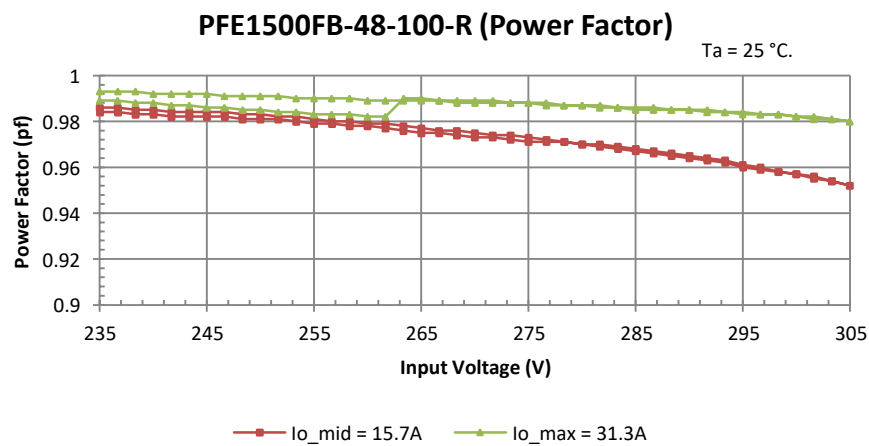
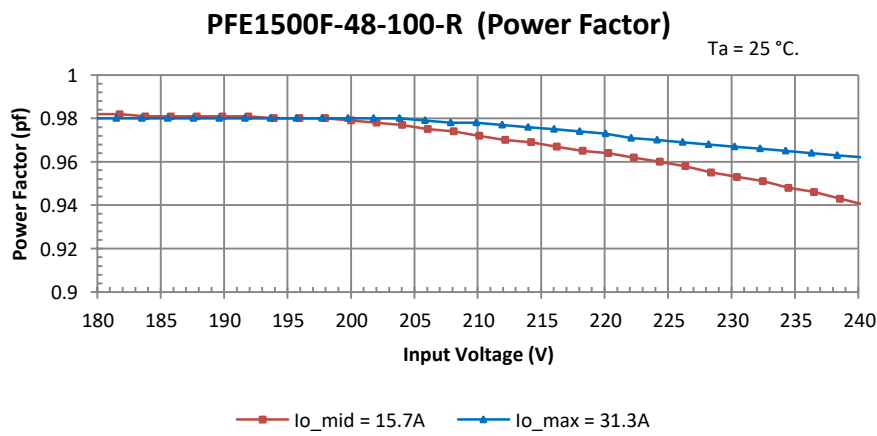
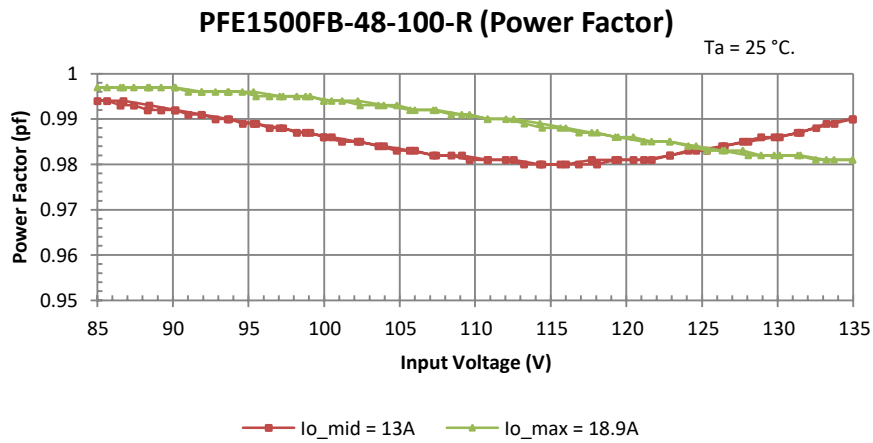

2.1.4 Output behavior with input line sweep (60 Hz)

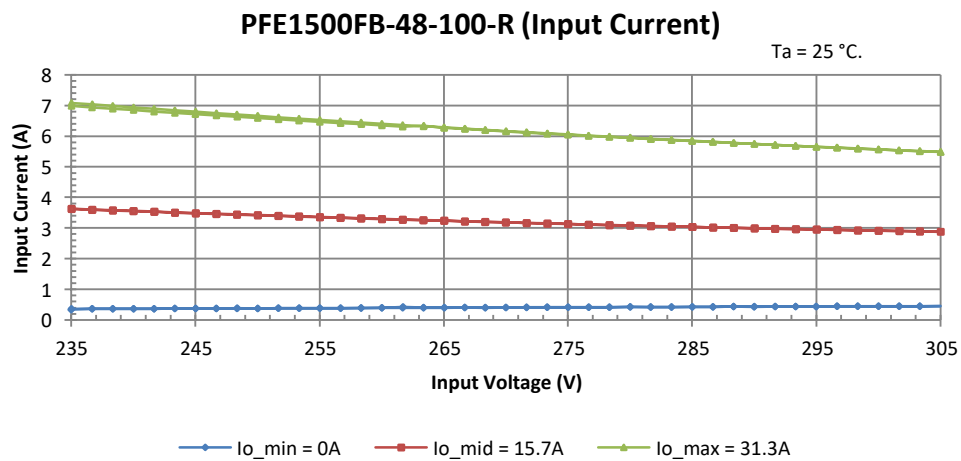
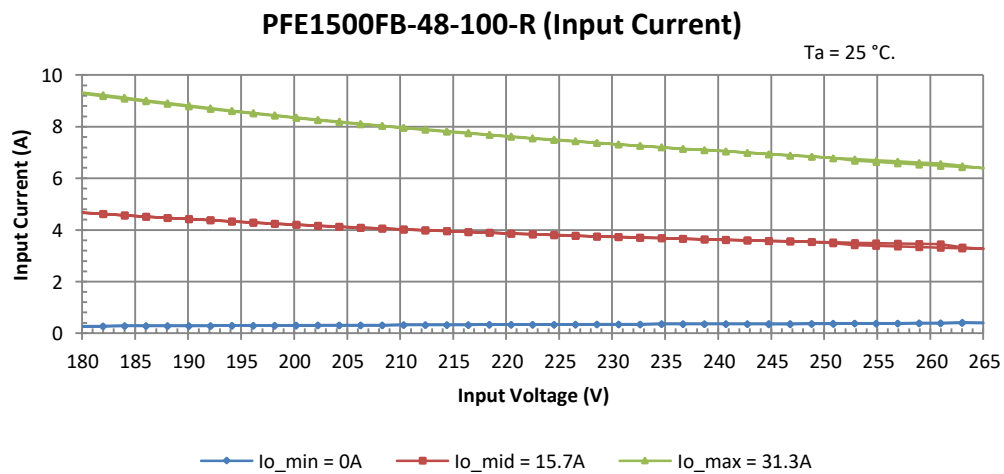
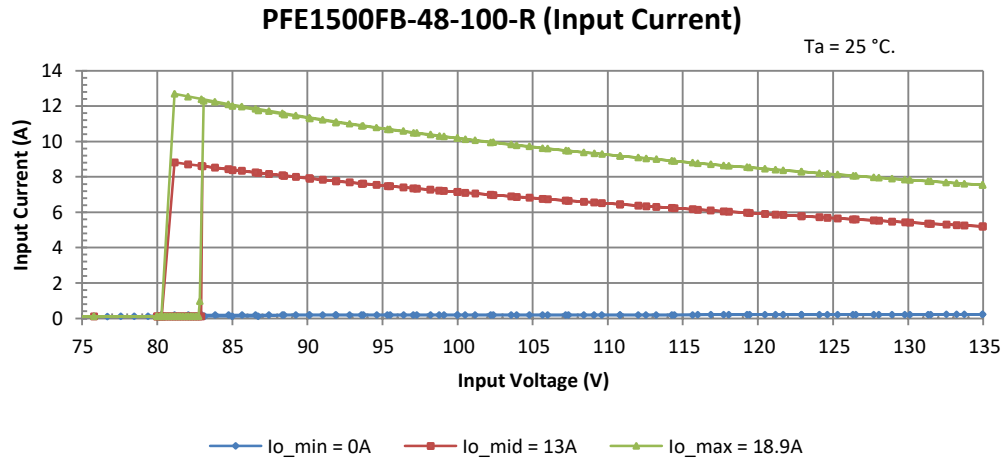

Over Current Protection (OCP) Characteristics (Refer to section 1.1.2 for Test Setup) (60 Hz)

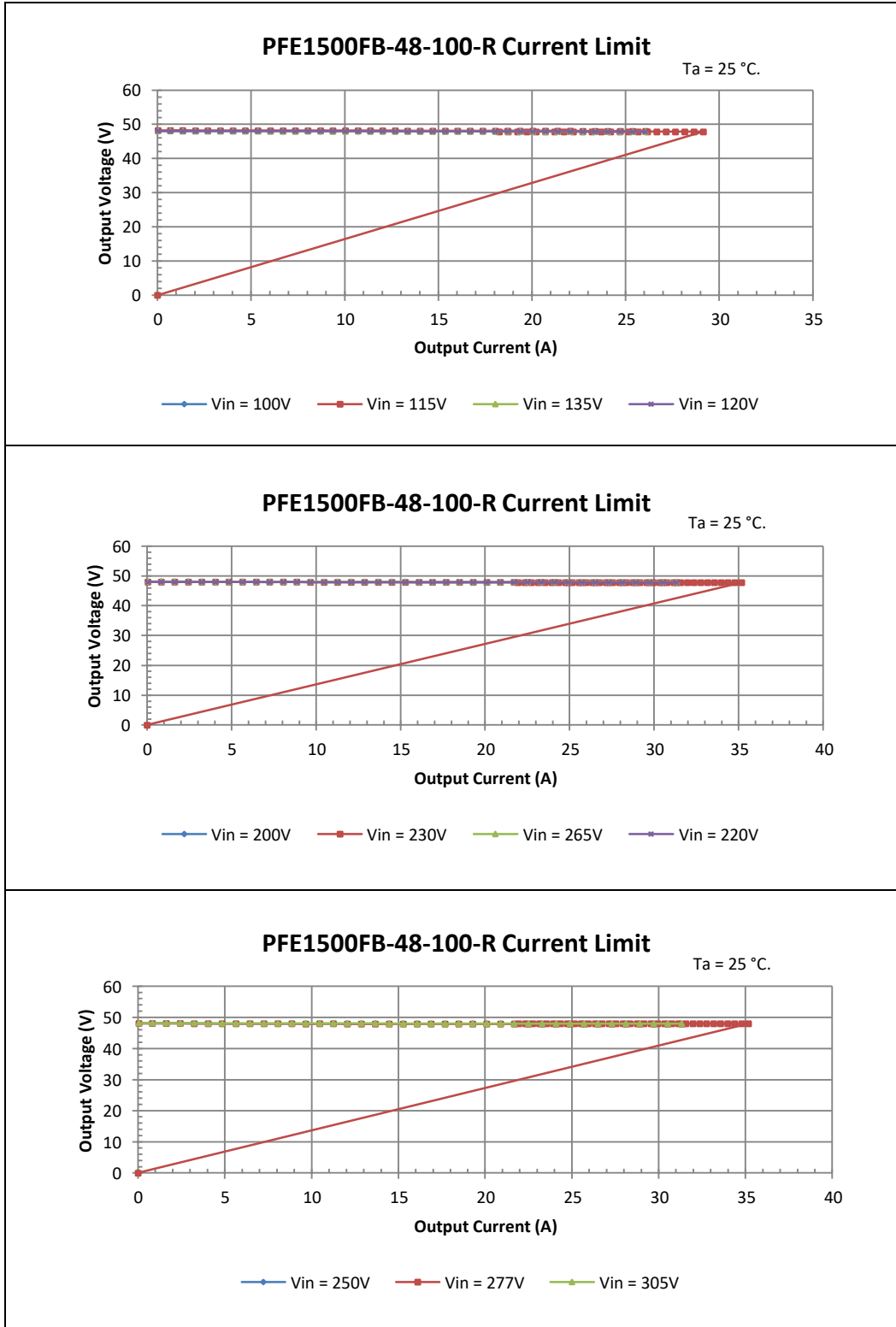

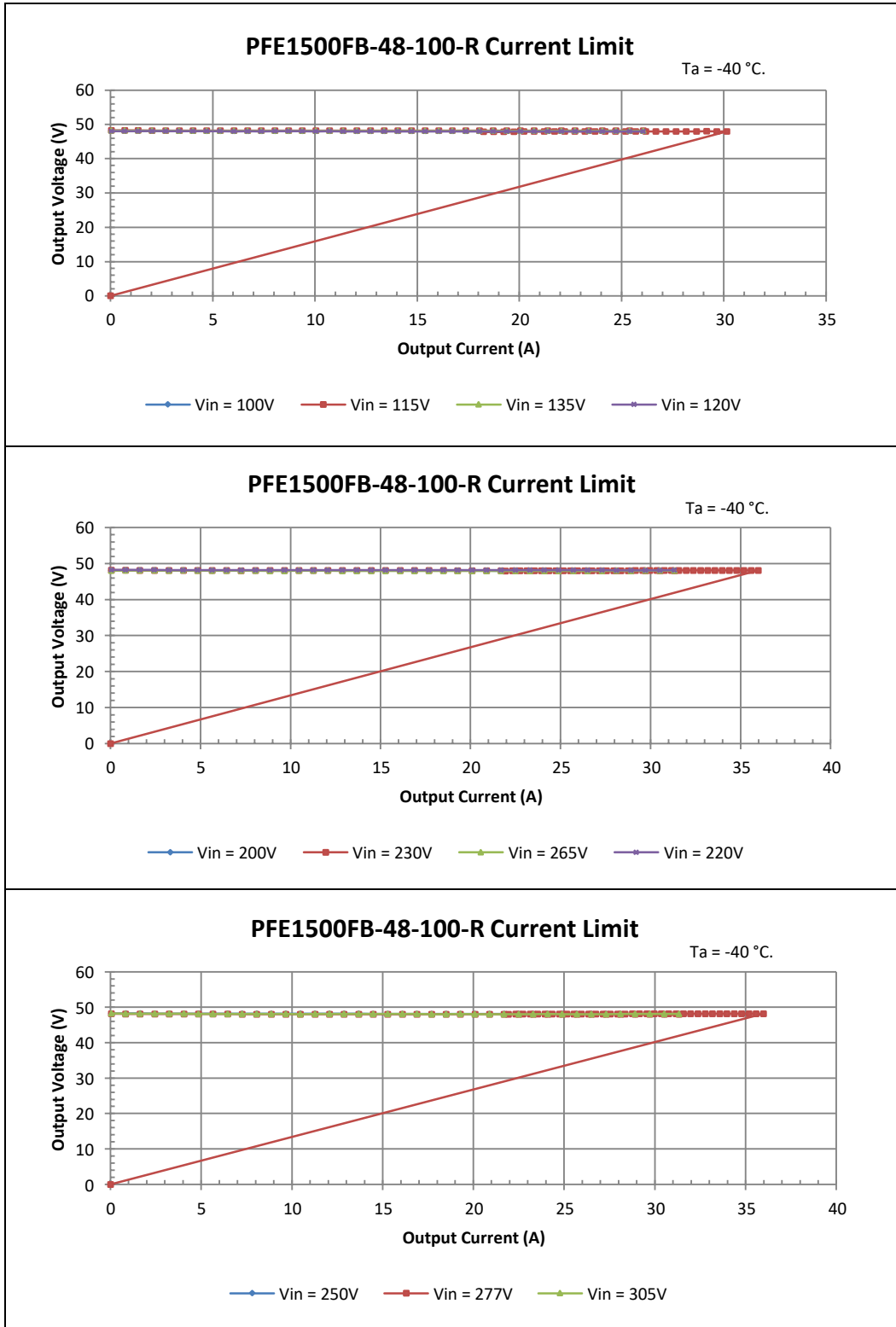

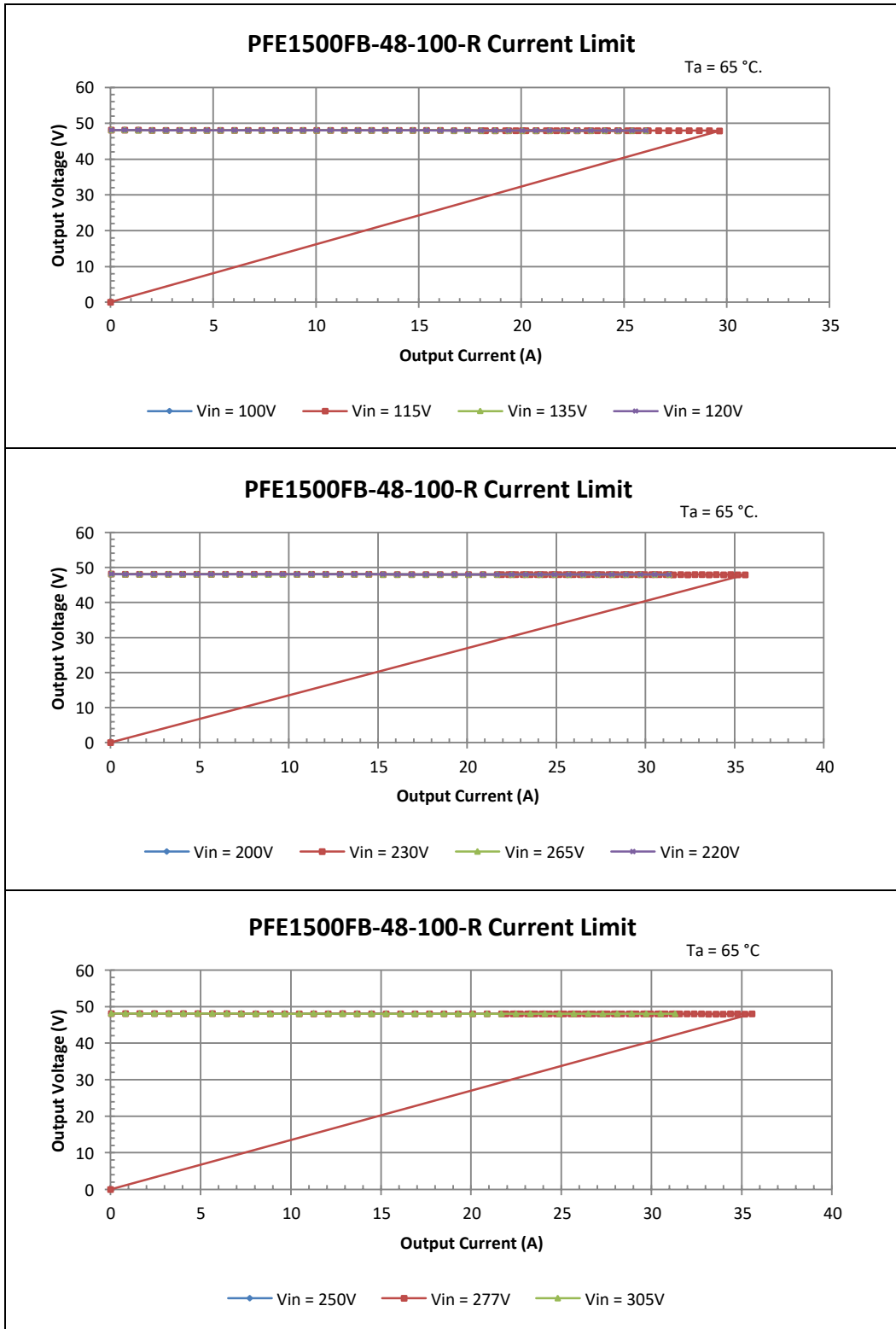

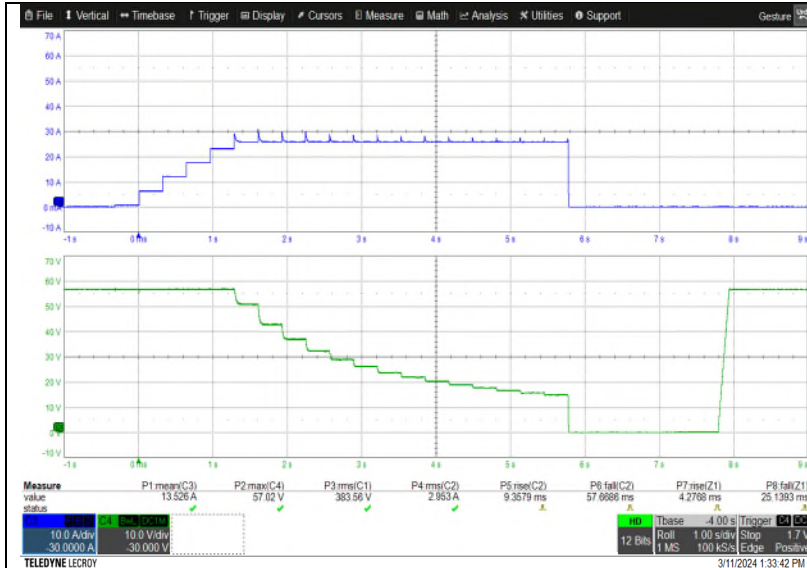

Voltage Foldback

Current Limit is 26A.

Load is increased step by step until Output hits UVP hiccup.

Output recovers after 2 secs after the load is removed.

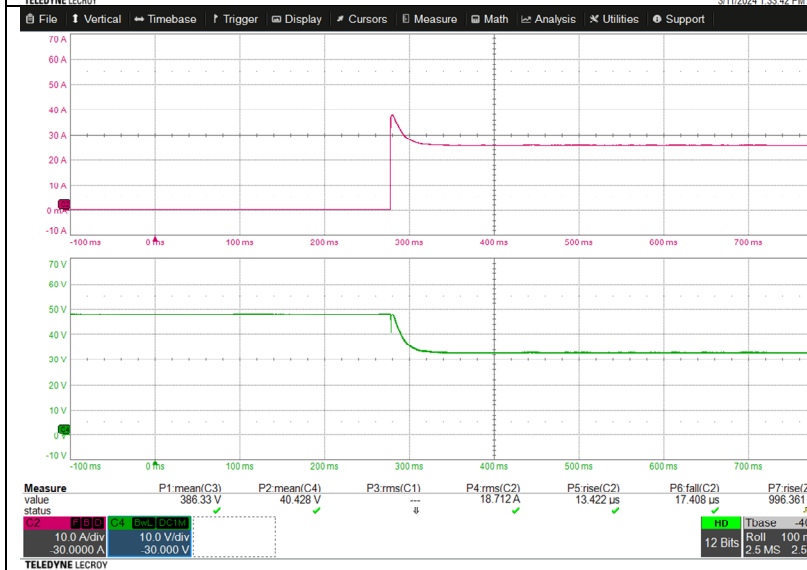

Voltage Foldback

Load is stepped from 0→38.4A.

Output folds back to 32.5V and recovers after overload is removed.

2.2 Over Voltage Protection (OVP) Characteristics (Refer to Section 1.1.2 for Test Setup)

Conditions: Set Point = 55V	$I_{out} = 4A$
	$T_a = 25\text{ }^\circ\text{C}$
	$V_{IN} = 115\text{ Vac}$

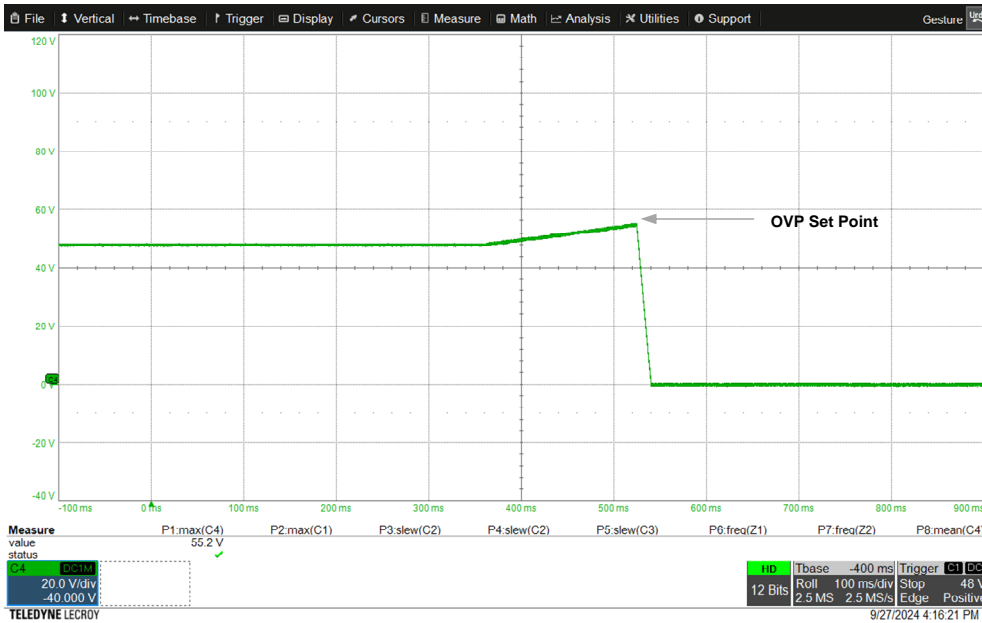

2.3 Output Rise and Fall Characteristics with AC Turn On

CH1: AC line at fixture input, CH2: AC input current, CH3: Vbus, CH4: Vout

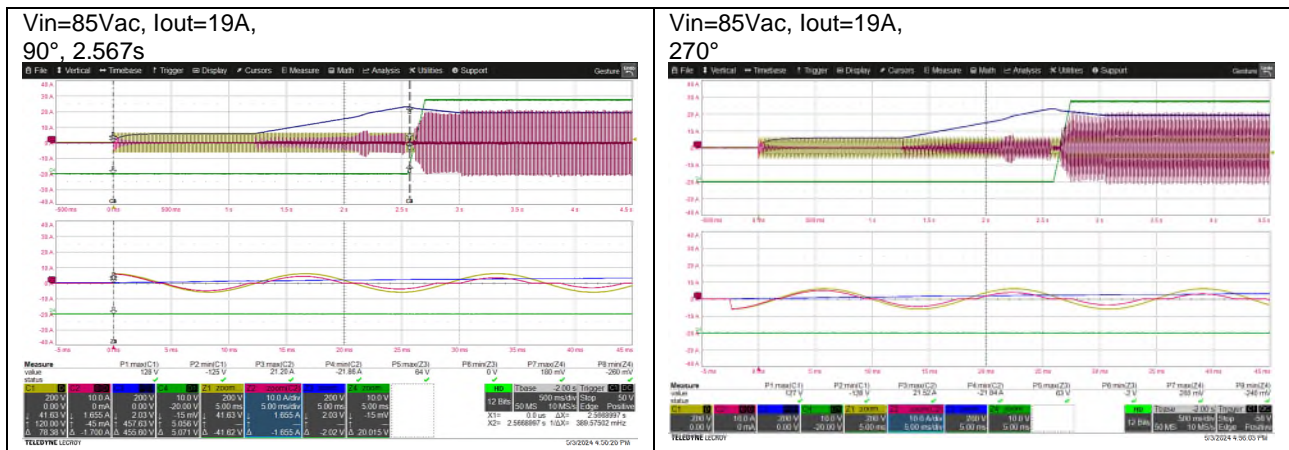

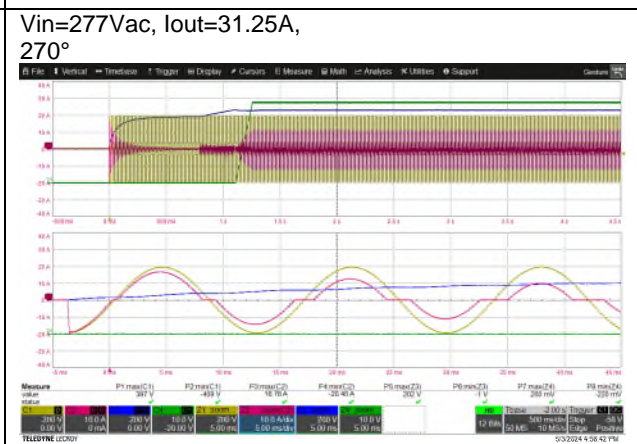
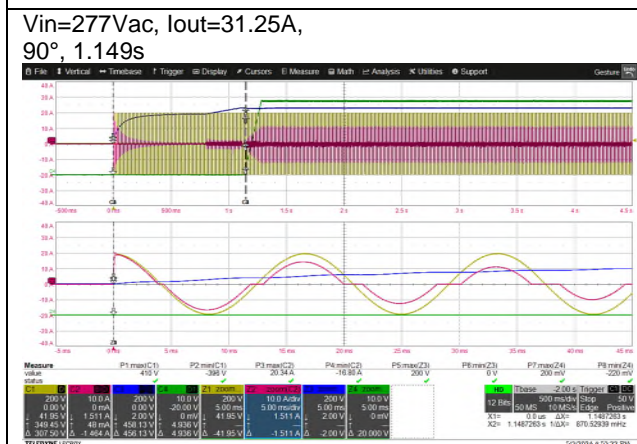
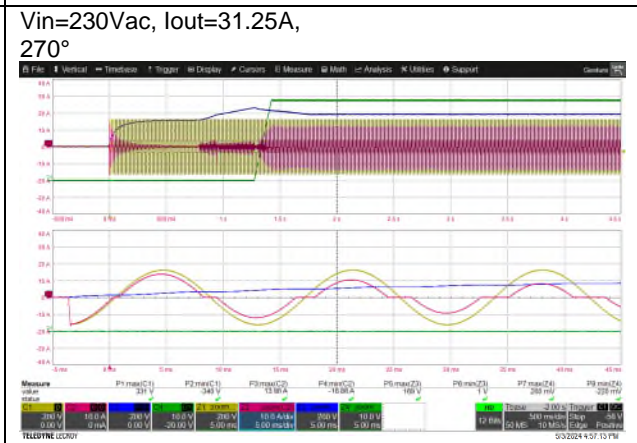
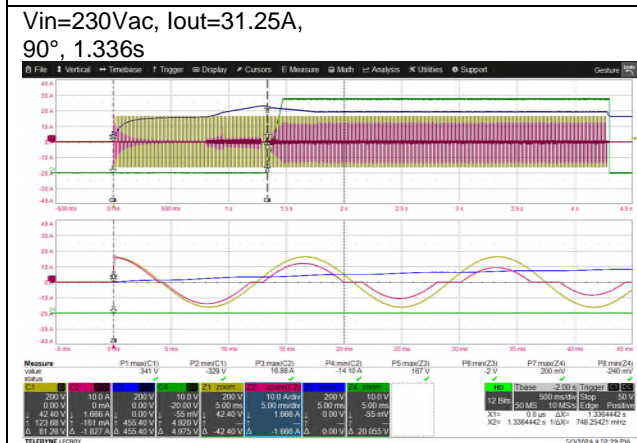
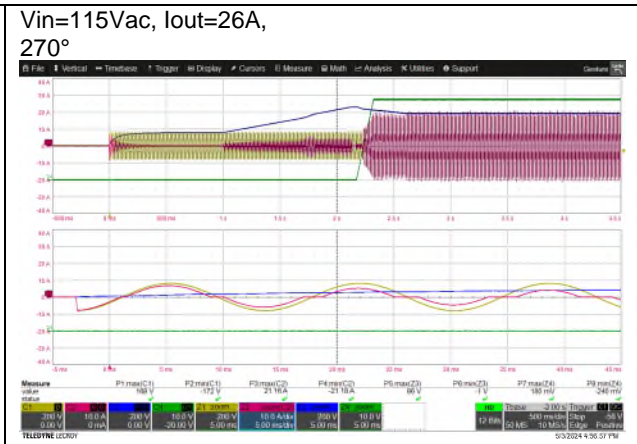
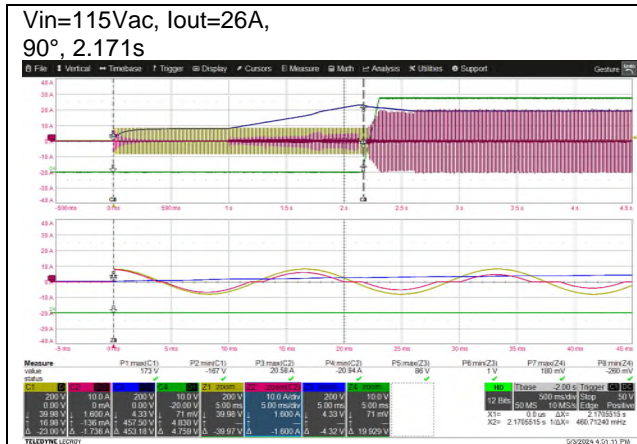

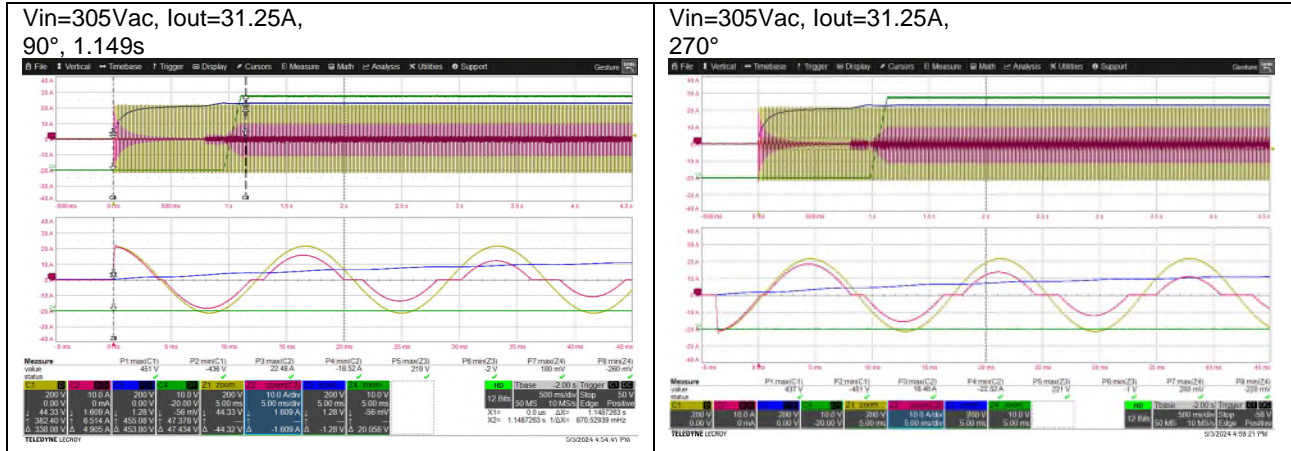

2.4 Hold Up Time Characteristic

CH1: AC line at fixture input, CH2: AC input current, CH3: Vbus, CH4: Vout

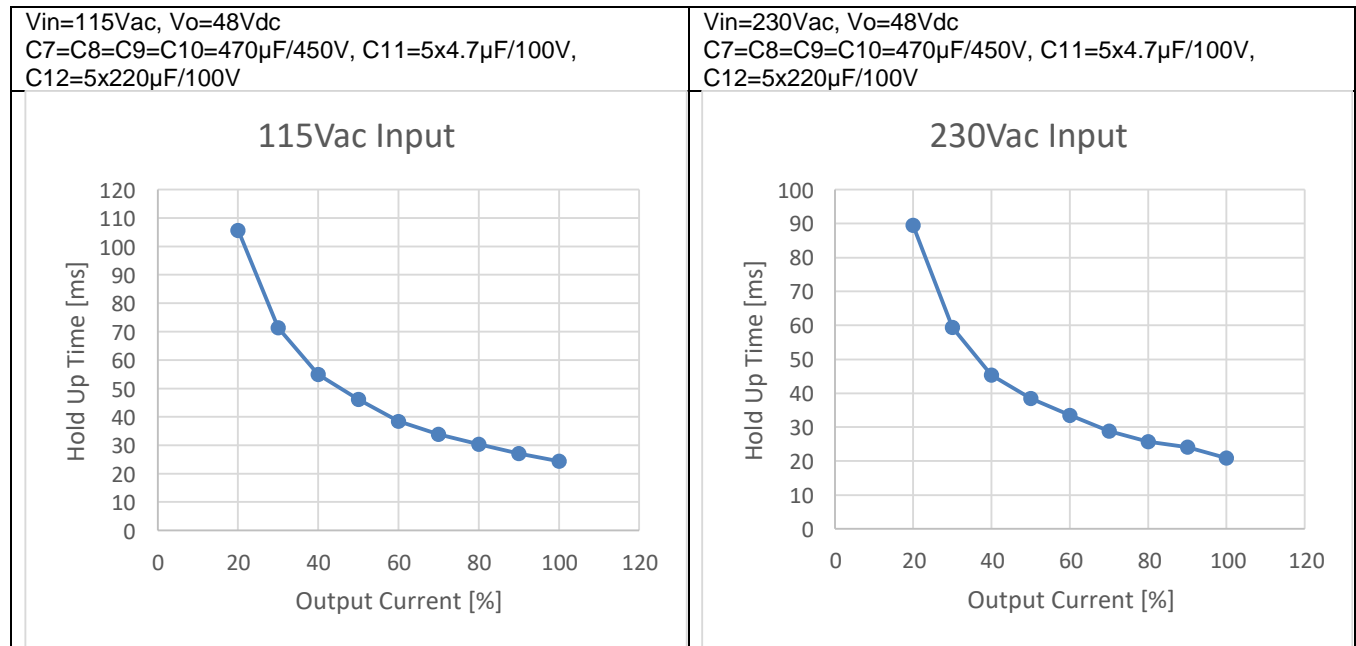
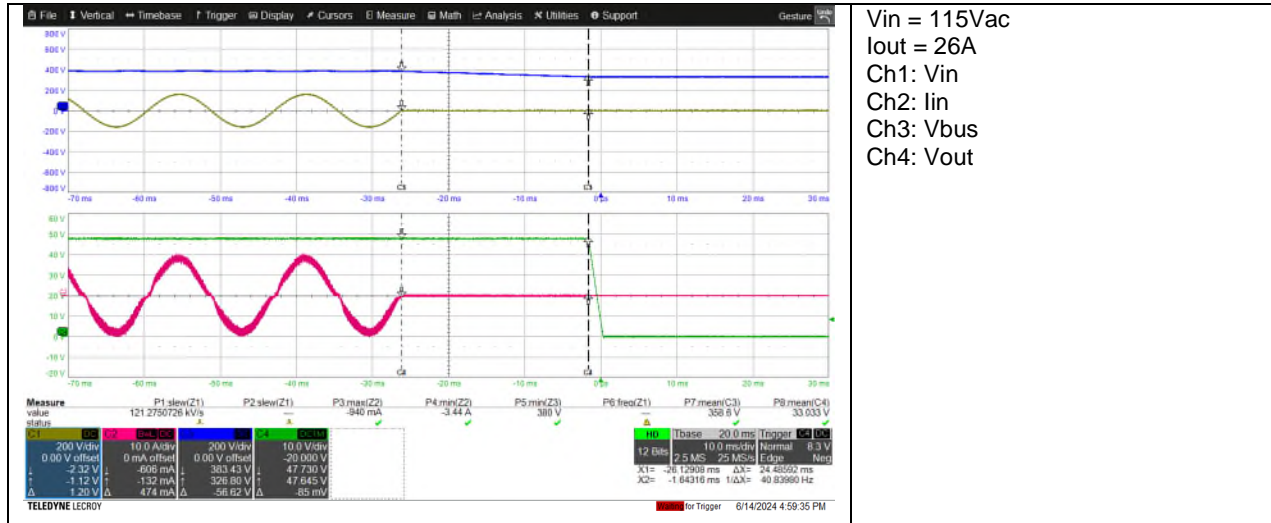

2.5 Dynamic Line Response (60 Hz)

CH1: AC line at fixture input, CH2: AC input current, CH3: Vbus, CH4: Vout



2.6 Dynamic Load Response

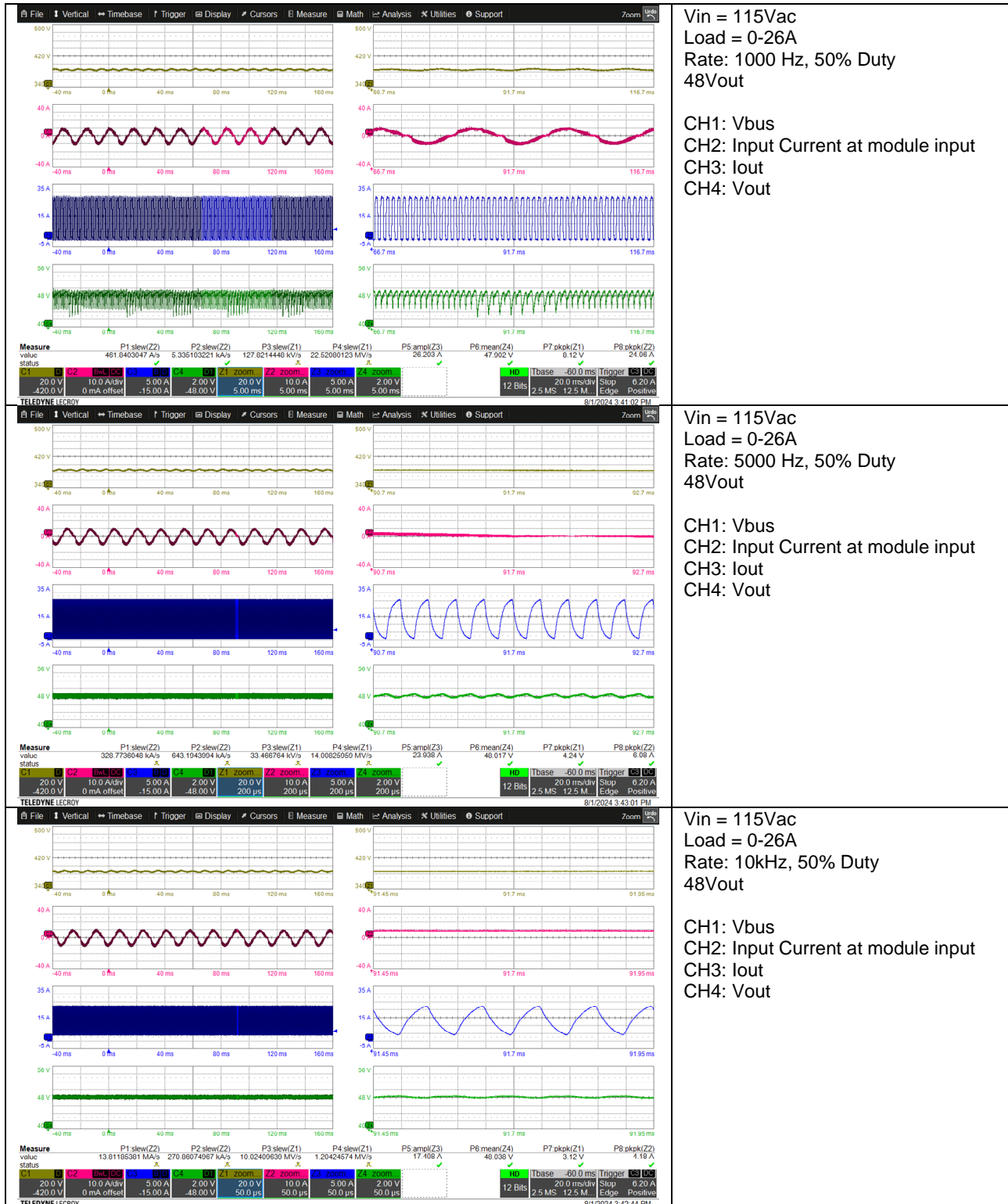

2.7 Input Current Waveform

$V_{IN} = 115 \text{ Vac } 60 \text{ Hz}; I_{out} = 26\text{A}$
CH2: V_{IN} ; CH3: I_{IN}

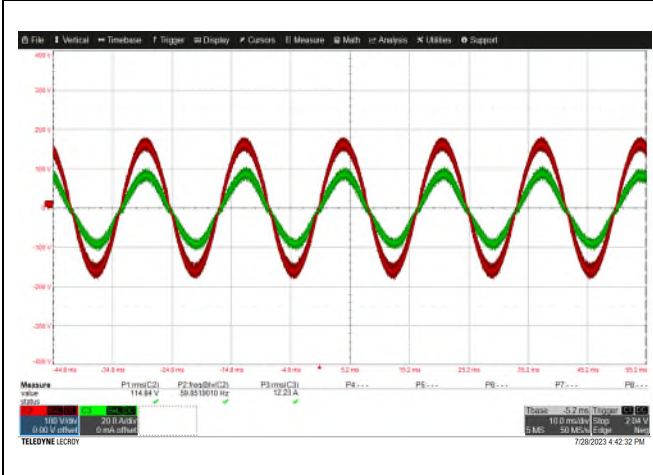

Current (THD = 3.81%) (PF = 0.998)

$V_{IN} = 230 \text{ Vac } 60 \text{ Hz}; I_{out} = 31.25\text{A}$
CH2: V_{IN} ; CH3: I_{IN}

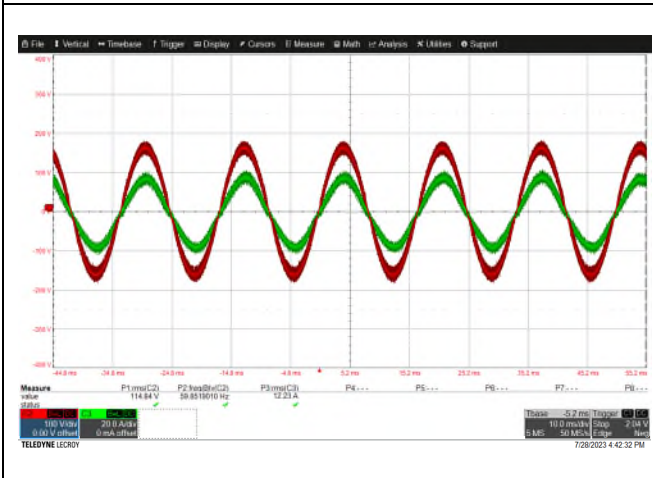

Current (THD = 6.065%) (PF = 0.967)

2.8 Input Current Harmonics

230 Vac, 50 Hz, 31.25A

V	I	W	PF	FREQ	THDI
229.181V	7.16596A	1.62580kW	0.9899	49.9998Hz	9.6018%

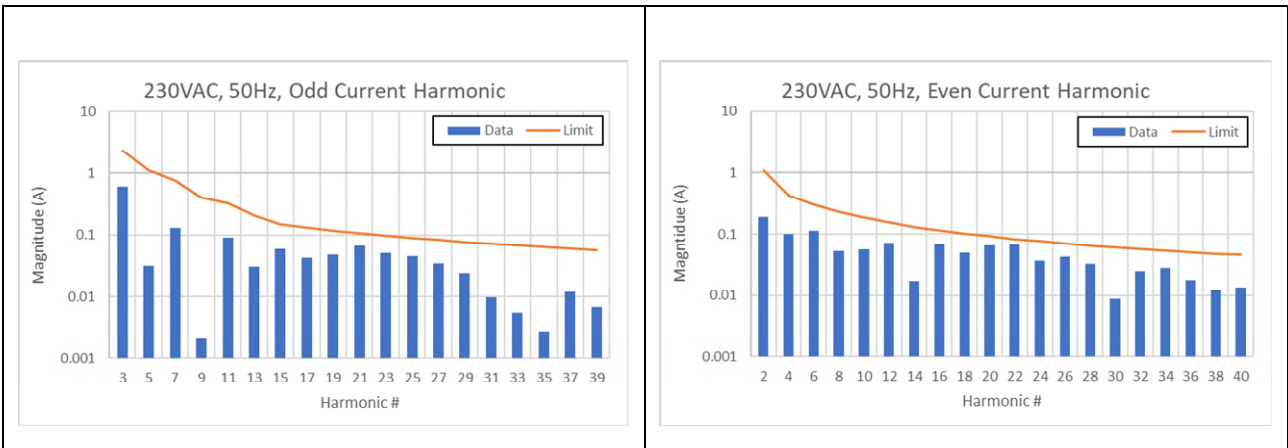

230 Vac, 60 Hz, 31.25A

V	I	W	PF	FREQ	THDI
229.173V	7.18244A	1.62731kW	0.9886	59.9998Hz	9.5382%

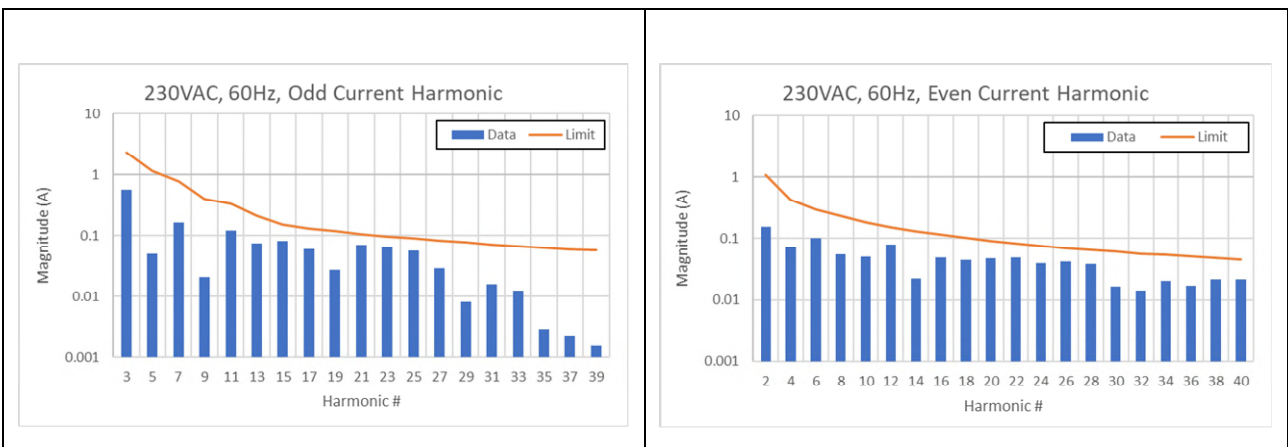

2.9 Input Inrush Current

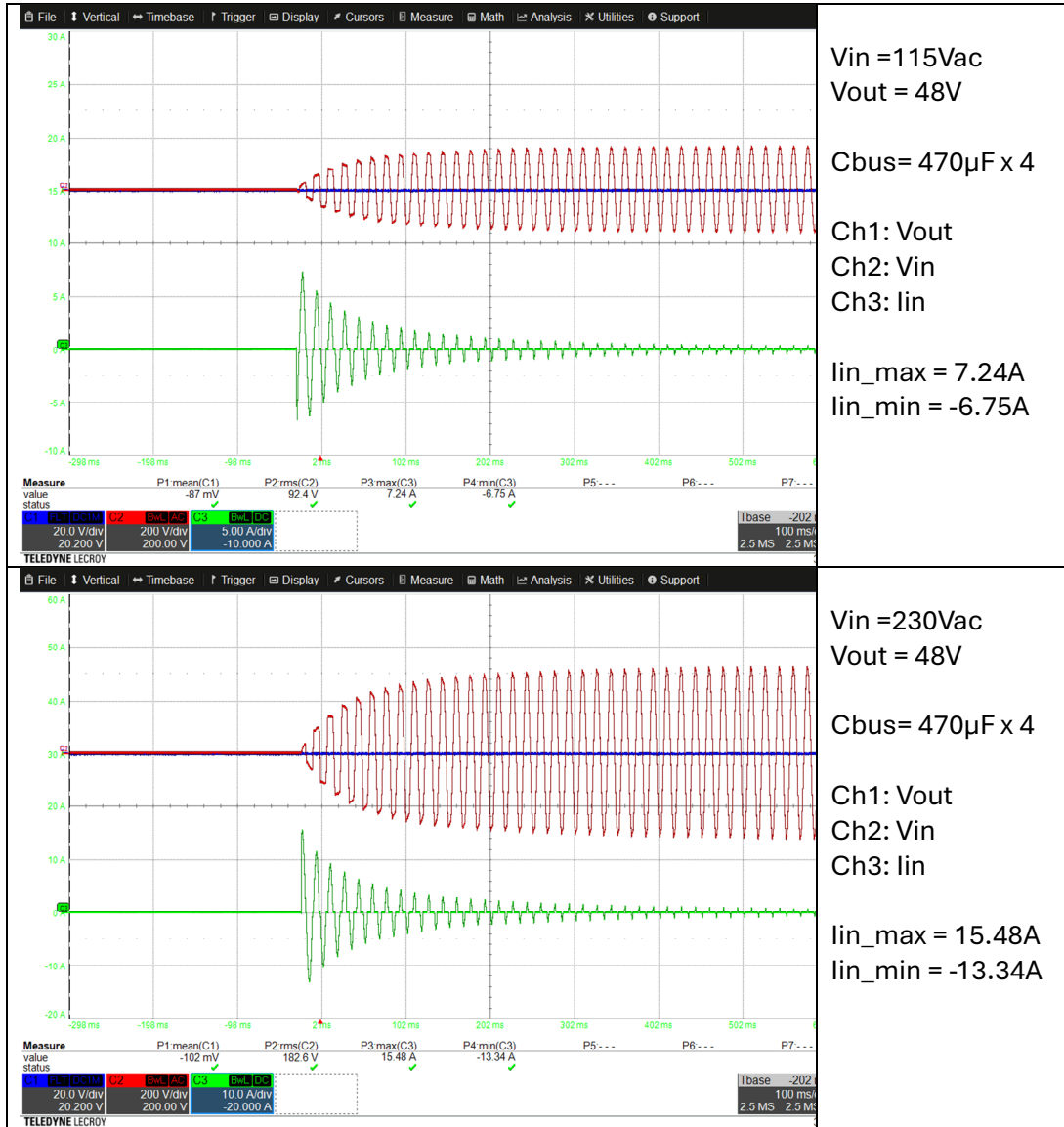

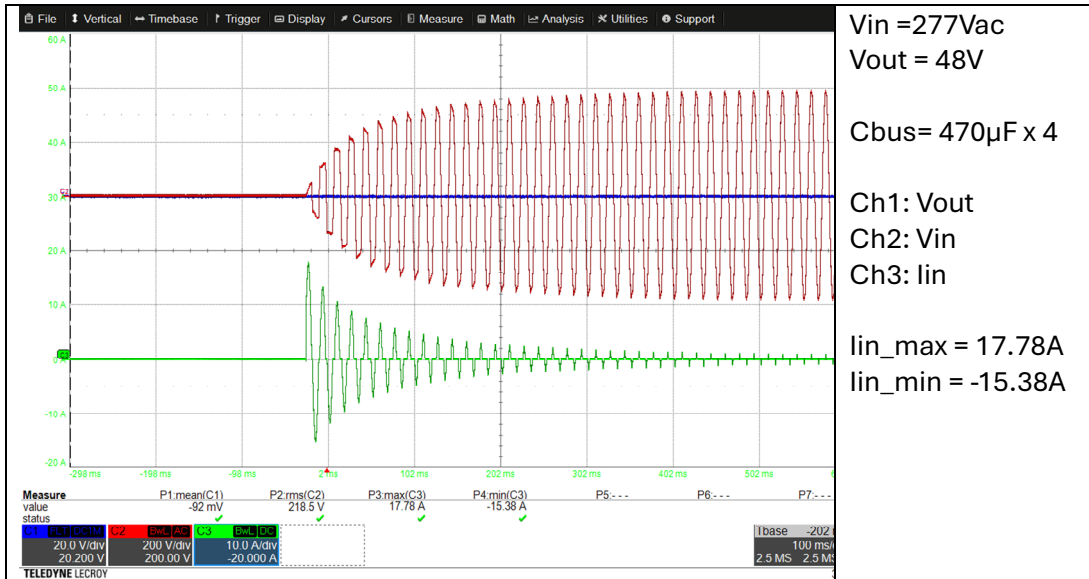

2.10 Brownout Data

Vout = 48V

Hardware: Open-frame, Vbus 4*470μF (electrolytic cap), Output 5*220μF (electrolytic cap) 8*4.7μF ceramic cap.

Results table

A = criteria A - DUT operates within specification limits during and after test.

B = criteria B - DUT exhibits a change in performance when operating then self-recovered.

A/B = some are criteria A or criteria B based on start angle

A* = criteria A, but due to derate at low Vrms, either resistive load or foldback must be used. Otherwise, criteria B.

	50 Hz			60 Hz		
	115Vac	230Vac	277Vac	115Vac	230Vac	277Vac
70% VAC, 0.5 cycle	A	A	A	A	A	A
40% VAC, 25 cycle	B	B	B	B	B	B
0% VAC, 250/300 cycles	B	B	B	B	B	B
0% VAC, 0.5 cycle	A	A/B	A	A	A	A
0% VAC, 1 cycle	B	B	A/B	B	B	A
40% VAC, 10 cycles	B	B	B	B	B	B
70% VAC, 25 cycles	B	A	A	B	A	A
80% VAC, 250 cycles	A*	A	A	A*	A	A
0% VAC, 250 cycles	B	B	B	B	B	B

2.11 Output Ripple and Noise

$T_a = 25\text{ }^\circ\text{C}$

$V_{IN} = 115\text{ Vac } 60\text{ Hz}; I_{out} = 3\text{ A}; V_O = 48\text{ Vdc}$

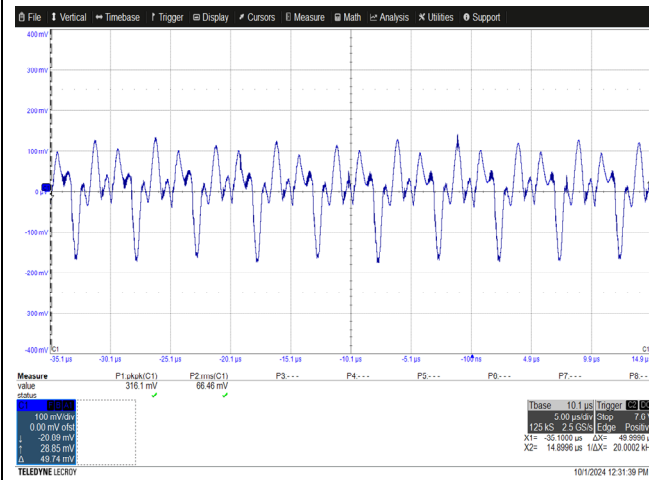

$V_{IN} = 115\text{ Vac } 60\text{ Hz}; I_{out} = 26\text{ A}; V_O = 48\text{ Vdc}$

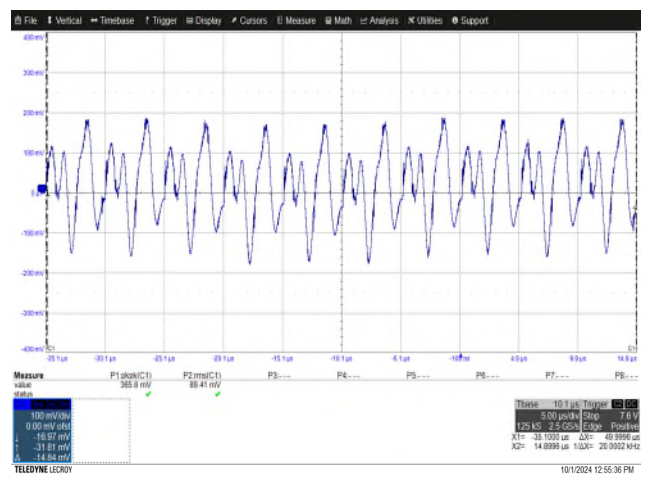

$V_{IN} = 230\text{ Vac } 60\text{ Hz}; I_{out} = 3\text{ A}; V_O = 48\text{ Vdc}$

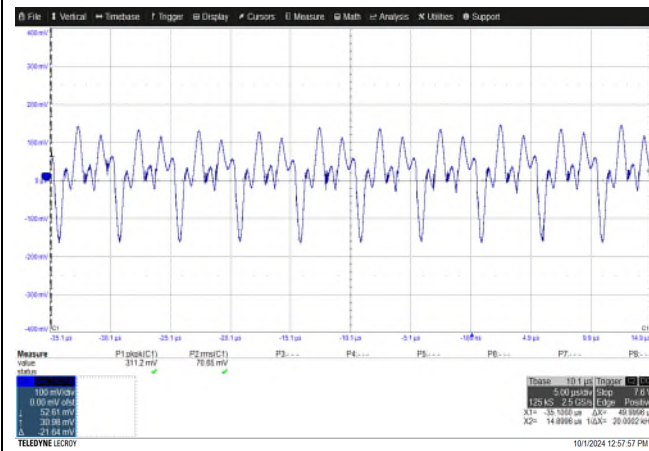

$V_{IN} = 230\text{ Vac } 60\text{ Hz}; I_{out} = 31.25\text{ A}; V_O = 48\text{ Vdc}$

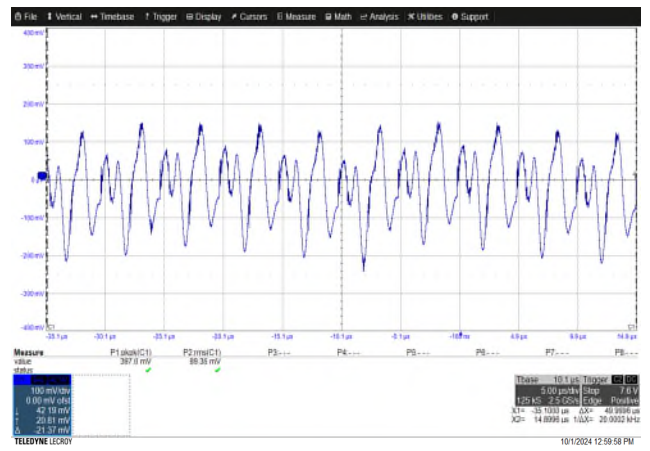

Information furnished by TDK-Lambda is believed to be accurate and reliable. However, TDK-Lambda assumes no responsibility for its use, nor for any infringement of patents or other rights of third parties, which may result from its use. No license is granted by implication or otherwise under any patent or patent rights of TDK-Lambda. TDK components are not designed to be used in applications, such as life support systems, wherein failure or malfunction could result in injury or death. All sales are subject to TDK-Lambda's Terms and Conditions of Sale, which are available upon request. Specifications are subject to change without notice.

TDK-Lambda



TDK-Lambda France SAS
 Tel: +33 1 60 12 71 65
france@fr.tdk-lambda.com
www.emea.lambda.tdk.com/fr



Italy Sales Office
 Tel: +39 02 61 29 38 63
info.italia@it.tdk-lambda.com
www.emea.lambda.tdk.com/it



Netherlands
info@nl.tdk-lambda.com
www.emea.lambda.tdk.com/nl



TDK-Lambda Germany GmbH
 Tel: +49 7841 666 0
info.germany@de.tdk-lambda.com
www.emea.lambda.tdk.com/de



Austria Sales Office
 Tel: +43 2256 655 84
info@at.tdk-lambda.com
www.emea.lambda.tdk.com/at



Switzerland Sales Office
 Tel: +41 44 850 53 53
info@ch.tdk-lambda.com
www.emea.lambda.tdk.com/ch



Nordic Sales Office
 Tel: +45 8853 8086
info@dk.tdk-lambda.com
www.emea.lambda.tdk.com/dk



TDK-Lambda UK Ltd.
 Tel: +44 (0) 12 71 85 66 66
powersolutions@uk.tdk-lambda.com
www.emea.lambda.tdk.com/uk



TDK-Lambda Ltd.
 Tel: +9 723 902 4333
info@tdk-lambda.co.il
www.emea.lambda.tdk.com/il



C.I.S.
Commercial Support:
 Tel: +7 (495) 665 2627
Technical Support:
 Tel: +7 (812) 658 0463
info@tdk-lambda.ru
www.emea.lambda.tdk.com/ru



TDK-Lambda Americas
 Tel: +1 800-LAMBDA-4 or 1-800-526-2324
powersolutions@us.tdk-lambda.com
www.us.lambda.tdk.com



TDK Electronics do Brasil Ltda
 Tel: +55 11 3289-9599
sales.br@tdk-electronics.tdk.com
www.tdk-electronics.tdk.com/en



TDK-Lambda Corporation
 Tel: +81-3-6778-1113
www.jp.lambda.tdk.com



TDK-Lambda (China) Electronics Co. Ltd.
 Tel: +86 21 6485-0777
powersolutions@cn.tdk-lambda.com
www.lambda.tdk.com.cn



TDK-Lambda Singapore Pte Ltd.
 Tel: +65 6251 7211
ts.mkt@sg.tdk-lambda.com
www.sg.lambda.tdk.com



TDK India Private Limited, Power Supply Division
 Tel: +91 80 4039-0660
mathew.philip@in.tdk-lambda.com
www.sg.lambda.tdk.com

For Additional Information, please visit
<https://product.tdk.com/info/en/products/power/index.html>

