

PFE1800FB-60-xxx-R

Evaluation Report



Table of Contents

1. EVALUATION METHOD	3
1.1. Test / Measurement Circuits	3
1.1.1. Steady State Test Measurement Circuit	3
1.1.2. Dynamic, Protection and Output Ripple and Noise Measurement Circuit.....	3
1.1.3. Inrush Current Measurement Circuit.....	4
1.1.4. Leakage Current Measurement Circuit.....	4
1.1.5. Electro-Magnetic Interference Test Set-Up	4
2.1 Steady State Data (Refer to Section 1.1.1 For Test Setup)	7
2.1.1 Regulation – Line, Load.....	7
2.1.2 Efficiency vs. Output Current (60Hz)	14
2.1.3 Power Factor (PF) vs. Input Voltage (60Hz).....	15
2.1.4 Output behavior with input line sweep (60Hz)	16
2.2 Over Voltage Protection (OVP) Characteristics (Refer to Section 1.1.2 for Test Setup)	21
2.3 Output Rise and Fall Characteristic with AC Turn On	22
2.4 Hold Up Time Characteristic	24
2.5 Dynamic Load Response	25
2.6 Input Current Waveform	26
2.7 Input Current Harmonics	27
2.8 Input Inrush Current	28
2.9 Brownout Data	29
2.11 Output Ripple and Noise	30

1. EVALUATION METHOD

1.1. Test / Measurement Circuits

1.1.1. Steady State Test Measurement Circuit

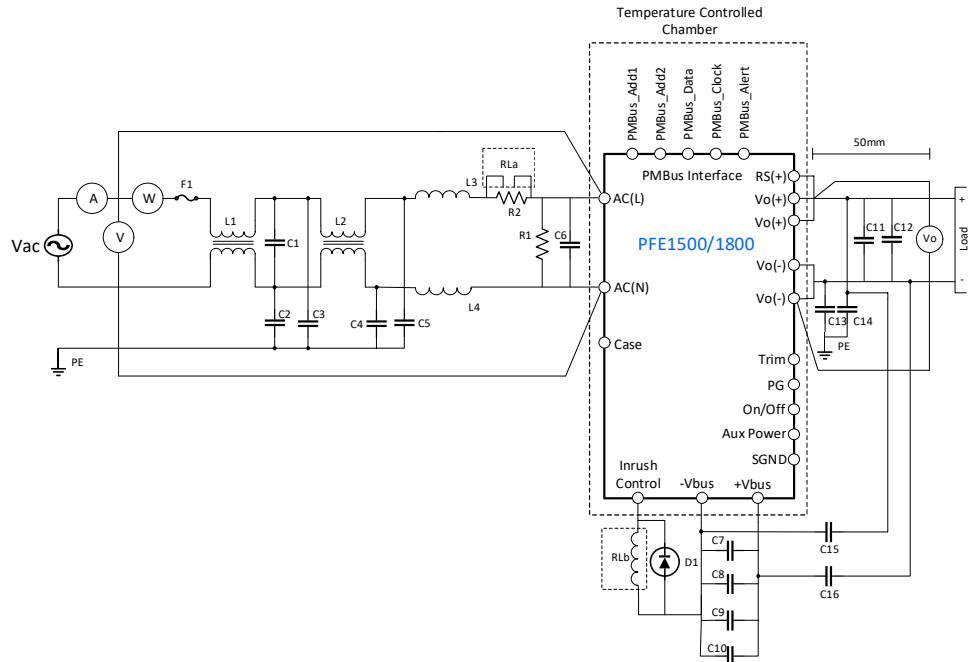

1.1.2. Dynamic, Protection and Output Ripple and Noise Measurement Circuit

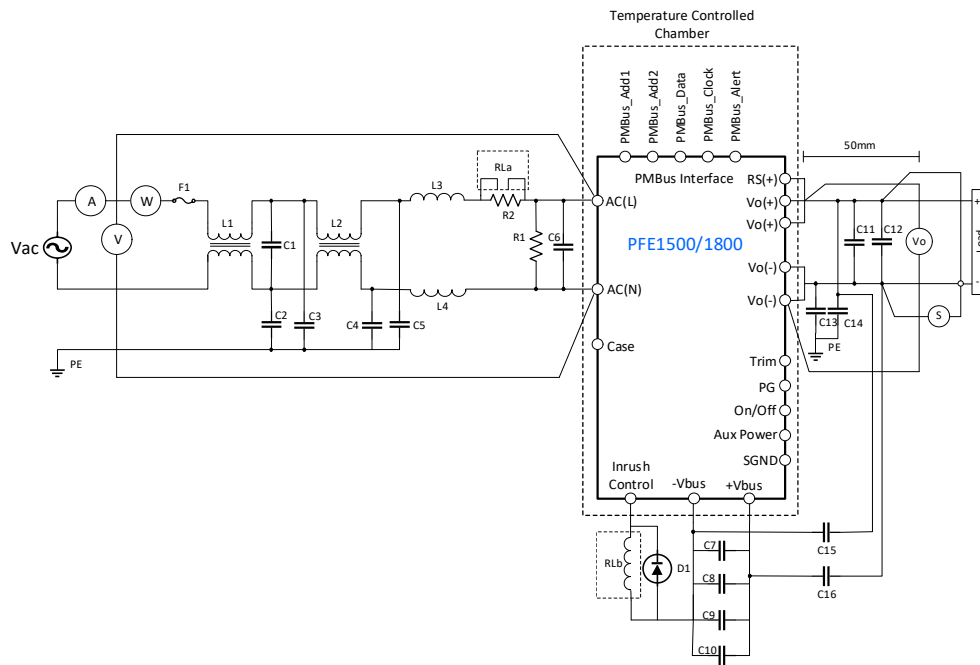

1.1.3. Inrush Current Measurement Circuit

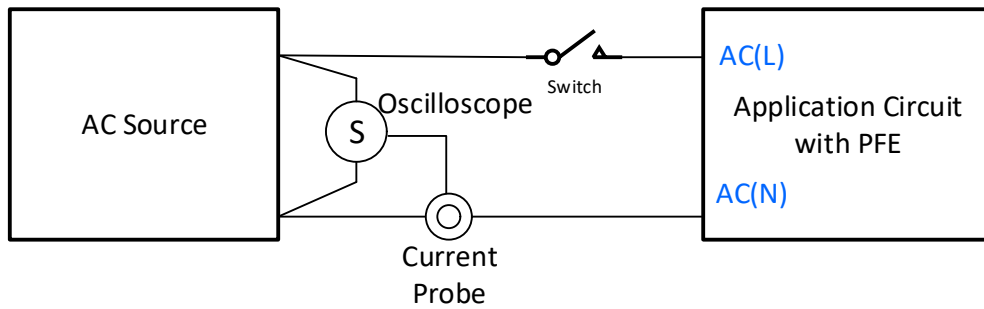

1.1.4. Leakage Current Measurement Circuit

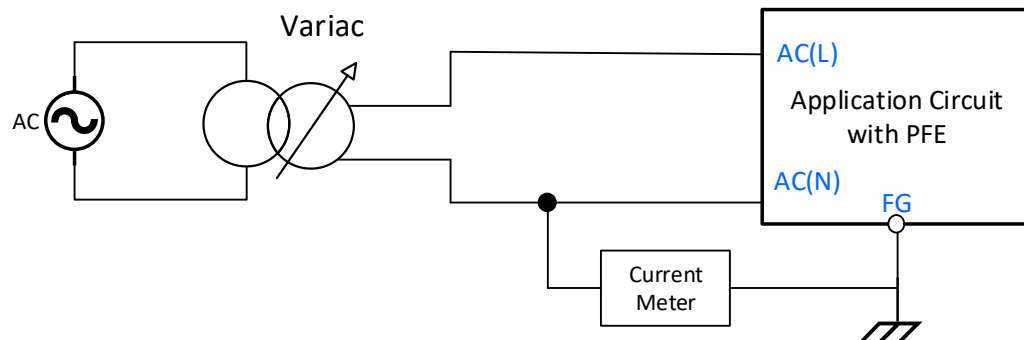

1.1.5. Electro-Magnetic Interference Test Set-Up

1.1.5.1. Conducted EMI

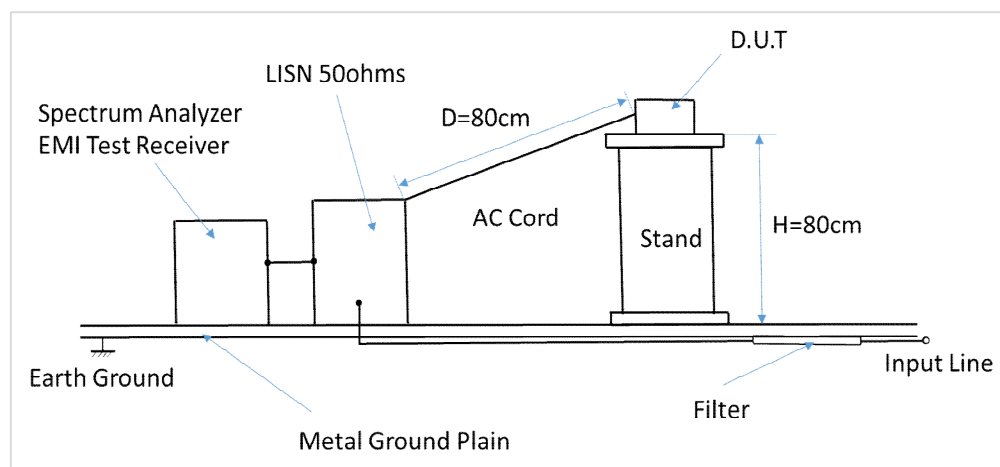

1.1.5.2. Radiated EMI

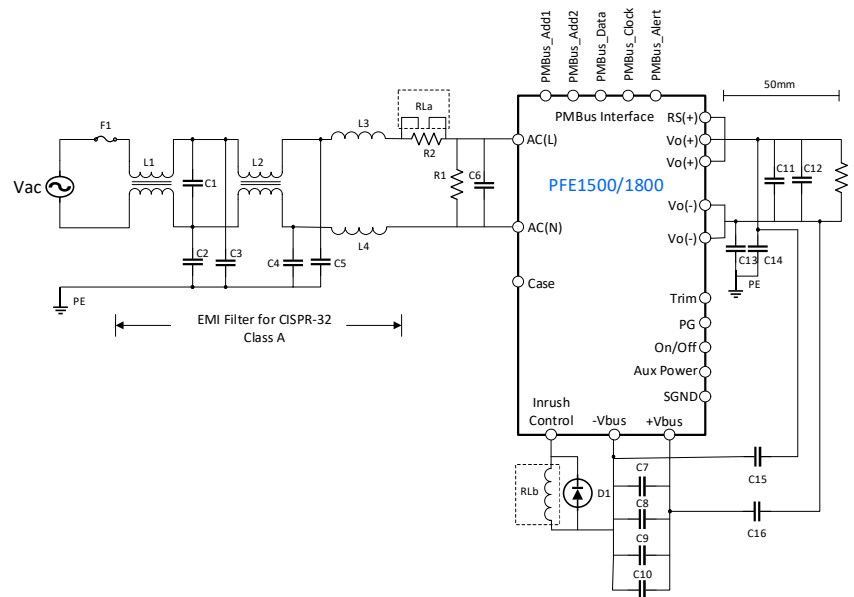
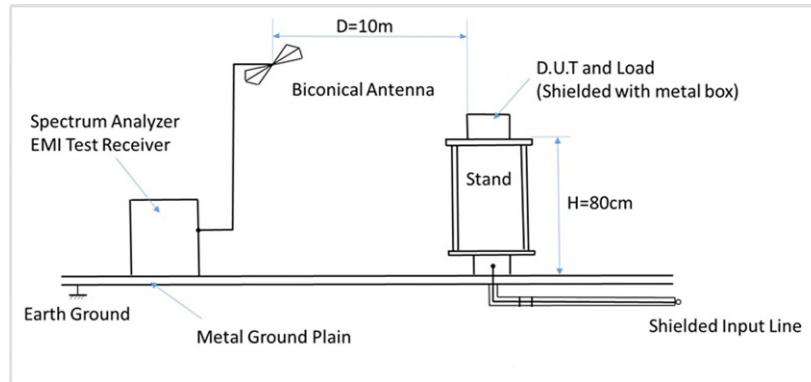

Circuit Reference	Description	Circuit Code	Description
C1	0.47 μ F Film Capacitor	C6	2x2.2 μ F Film Capacitor
C2, C3, C4, C5, C15, C16	4700pF Ceramic Capacitor	C13, C14	470pF Ceramic Capacitor
L1	1mH	R2	22 Ohms
L2	1.3mH	C12	5x220uF Electrolytic Capacitor
L3, L4	27 μ H	C11	8x4.7uF Ceramic Capacitor
R1	470kOhms	C7, C8, C9, C10	470 μ F Electrolytic Capacitor
RLa,RLb	1 Form A relay with 16A, 277VAC, power rating: 12VDC, 16.7mA, 200mW, High Sensitivity	F1	20A, 250V, Fast Blow
D1	200V, 1A PN Diode, Single Package, SMT		

List of Equipment

	EQUIPMENT USED	MANUFACTURER	MODEL NO.
1	OSCILLOSCOPE	LECROY	HDO 4054
2	OSCILLOSCOPE	LECROY	HDO 4054
3	DIGITAL MULTIMETER	KEITHLEY	2110
4	DIGITAL MULTIMETER	KEITHLEY	2110
5	DIFFERENTIAL AMPLIFIER	LECROY	DA1855A
6	DIFFERENTIAL AMPLIFIER	LECROY	DA1855A
7	SHUNT RESISTOR	EMPRO SHUNT	HA20-100
8	TEMP CHAMBER	TENNEY JUNIOR ENVIRONMENTAL	TJR
9	DIFFERENTIAL PROBE	LECROY	A101
10	DIFFERENTIAL PROBE	LECROY	DXG100A
11	DIGITAL POWER METER	YOKOGAWA	WT310
12	SURGE TESTER	TESEQ	NSG 3060A-ANSI
13	DC ELECTRONIC LOAD	CHROMA	63201
14	FREQUENCY ANALYZER	AP INSTRUMENT	300
15	AC POWER SOURCE	CHROMA	6530
16	INJECTION ISOLATOR	RIDLEY ENGINEERING	0.1Hz TO 30MHz
17	WAVEFORM GENERATOR	AGILENT	33120A
18	DC ELECTRONIC LOAD	CHROMA	6334
19	AC CONTROL	SORENSEN	DCS150-20
20	THERMOSTREAM	TEMPTRONIC CORPORATION	ATS-810-M-4
21	CURRENT PROBE	LECROY	AP015
22	CURRENT PROBE	LECROY	CP150

CHARACTERISTICS

2.1 Steady State Data (Refer to Section 1.1.1 For Test Setup)

2.1.1 Regulation – Line, Load

a. Line Regulation (60Hz)

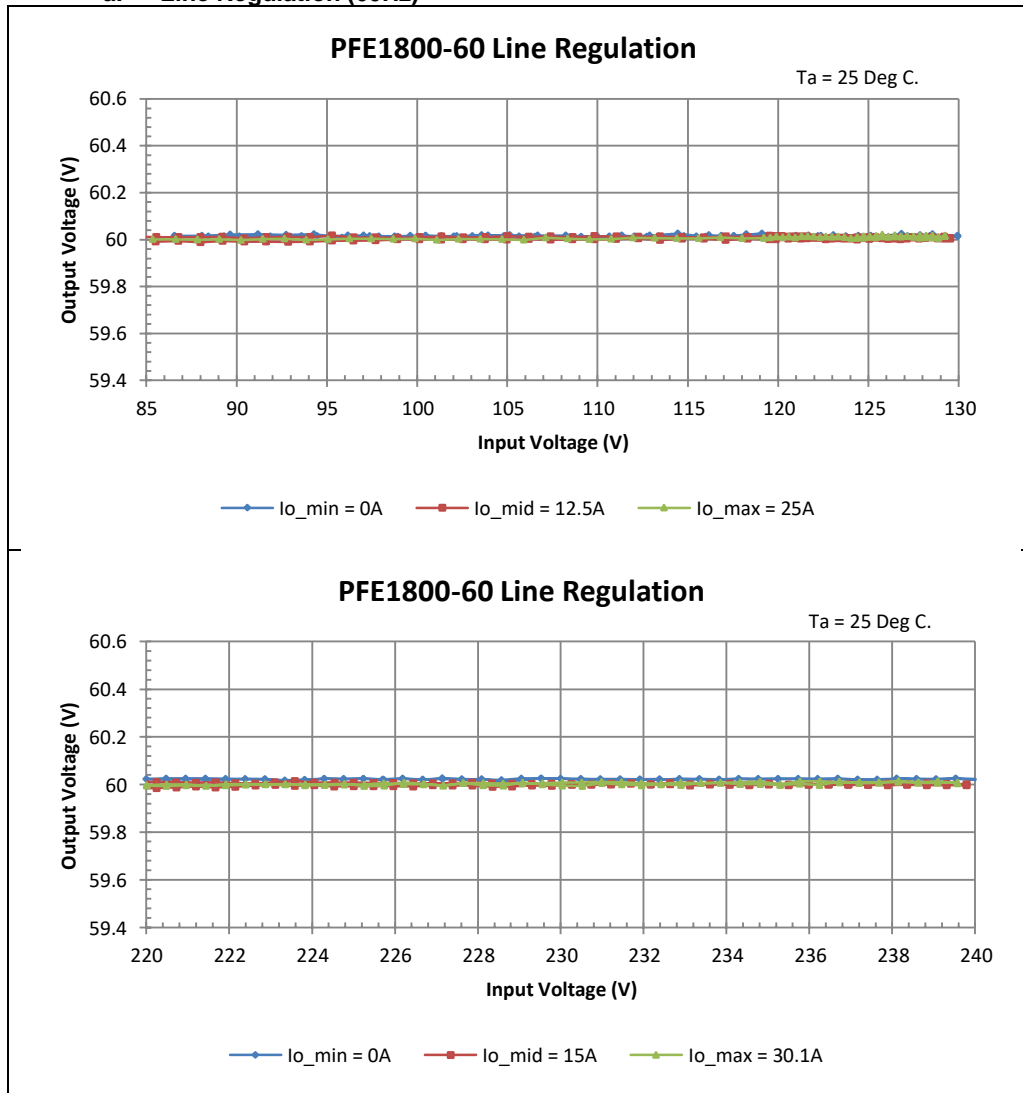

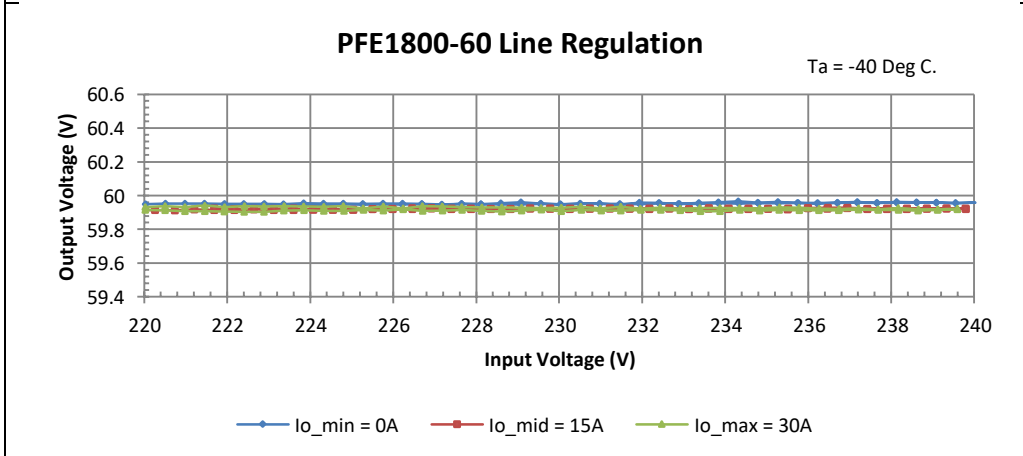
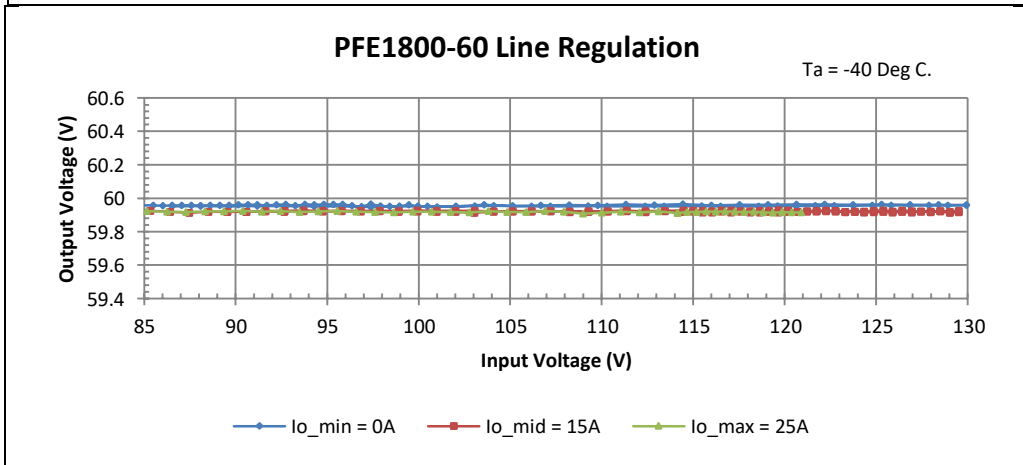
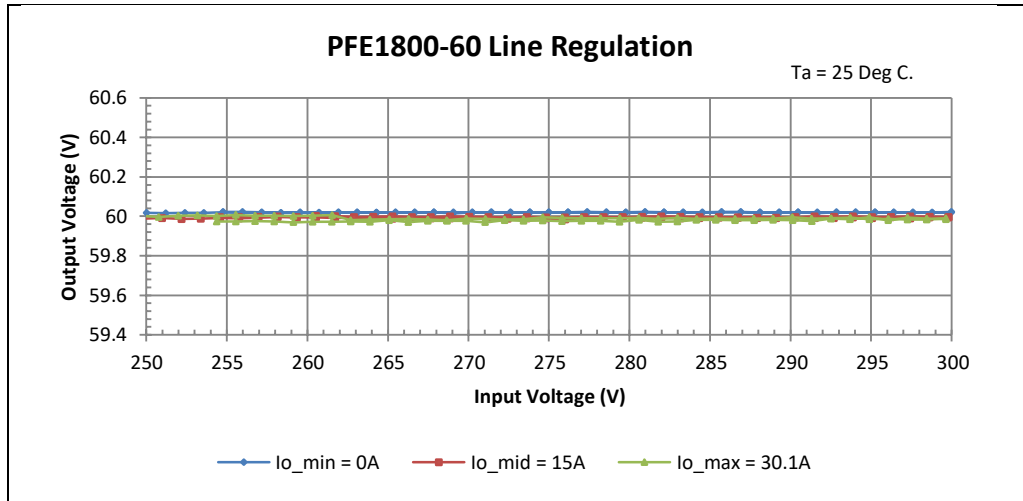

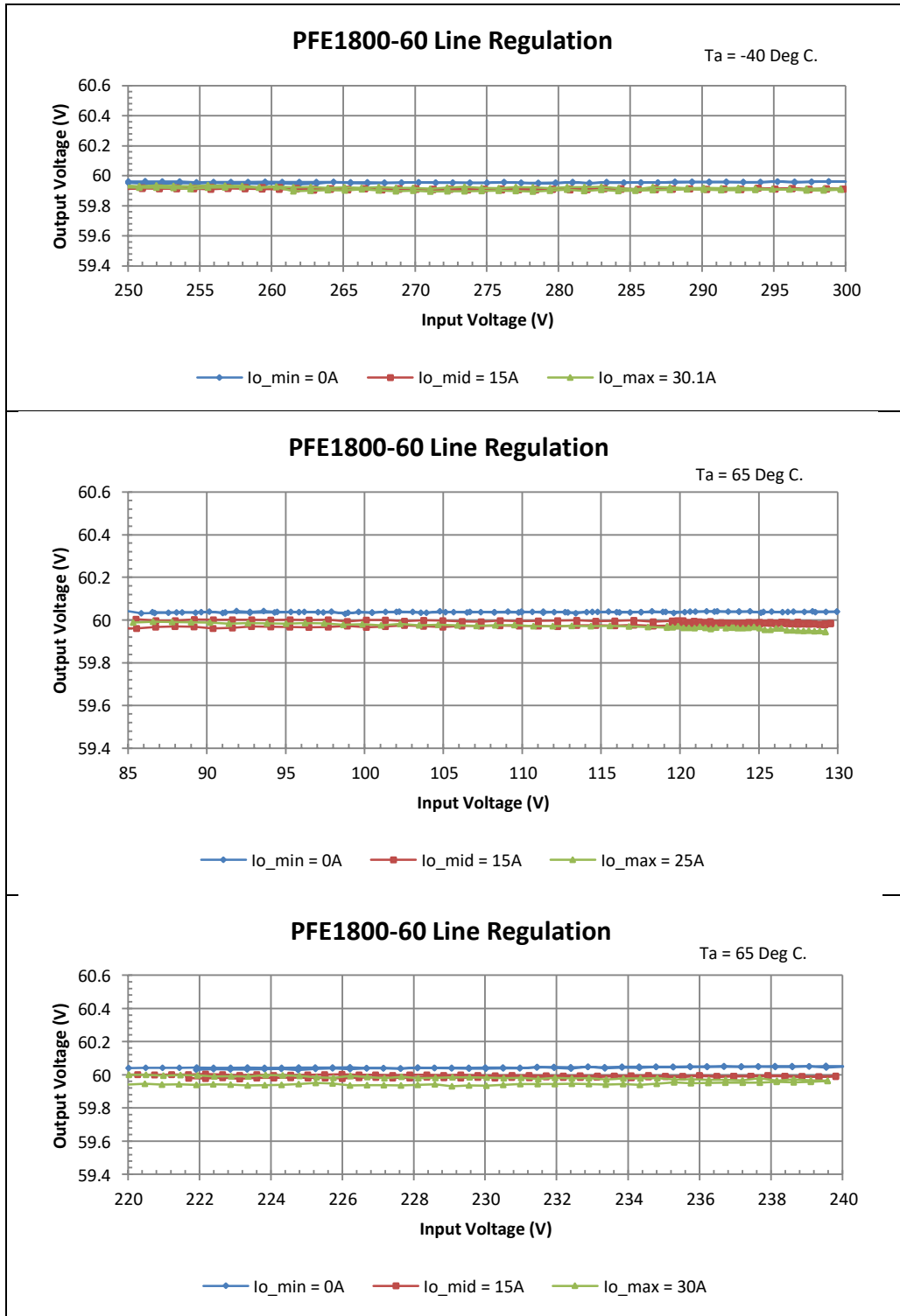

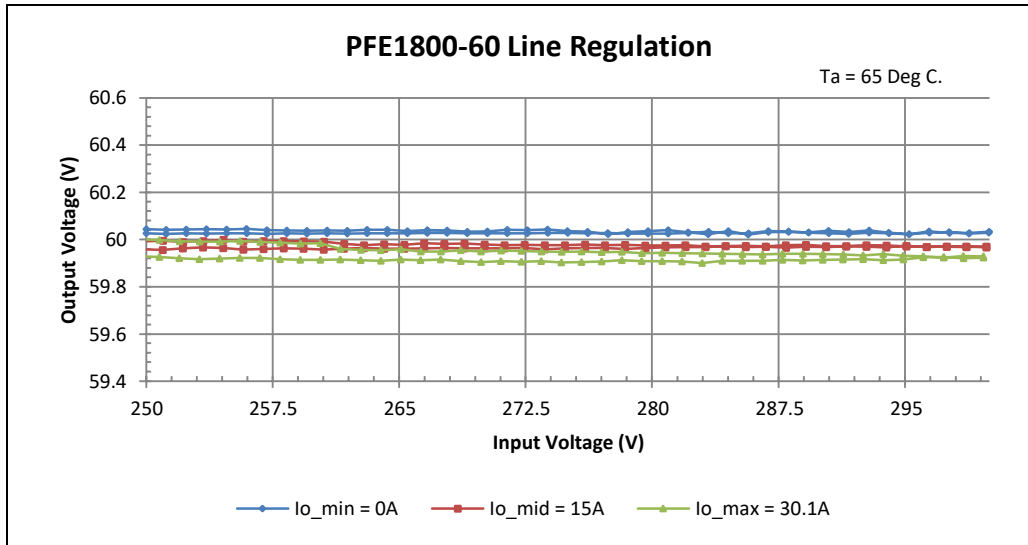

b. Load Regulation (60Hz)

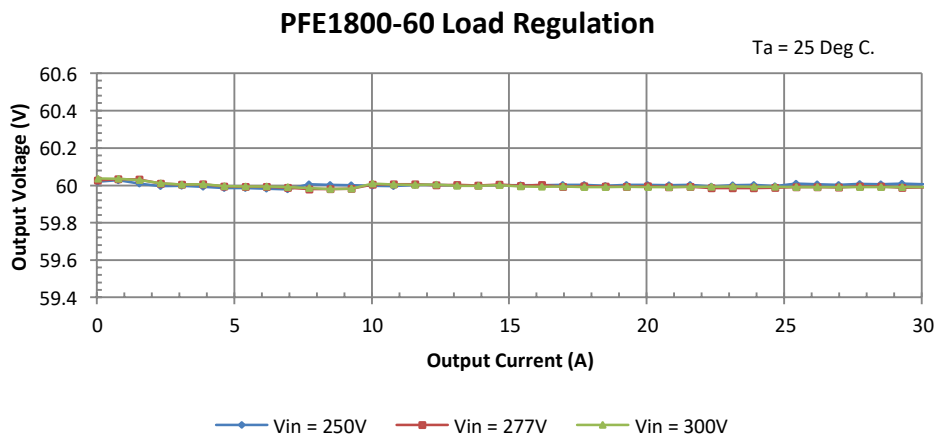
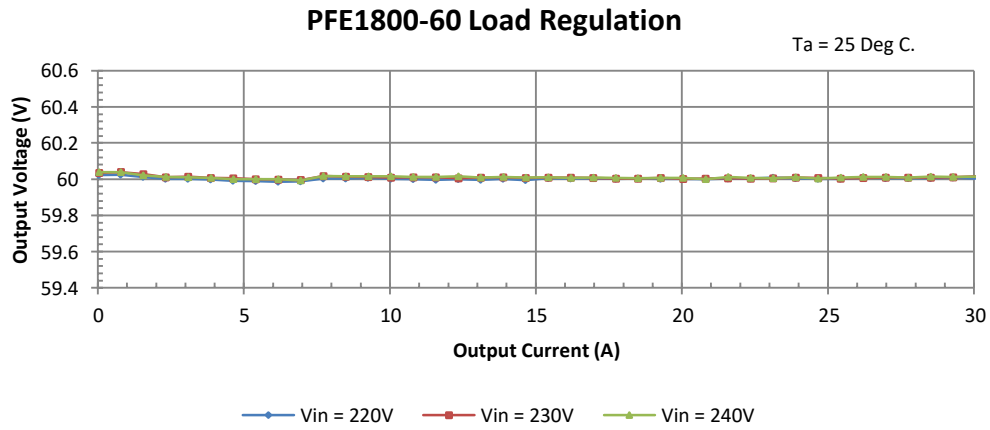
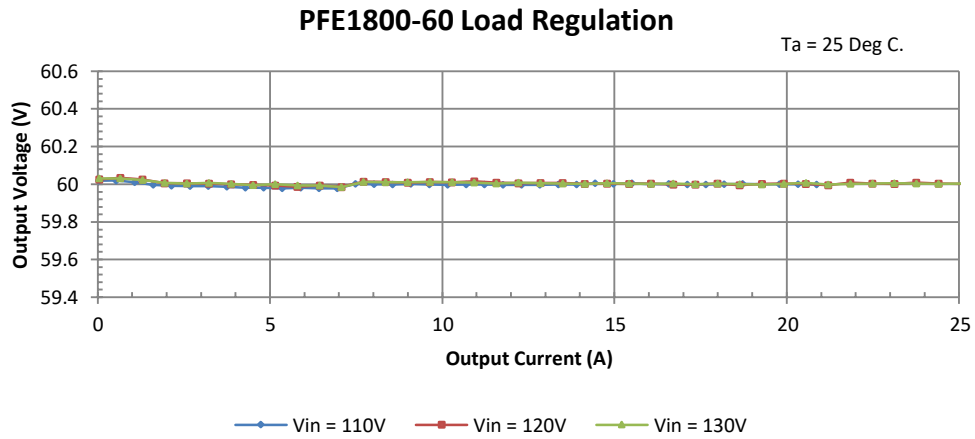

PFE1800-60 Load Regulation

Ta = -40 Deg C.

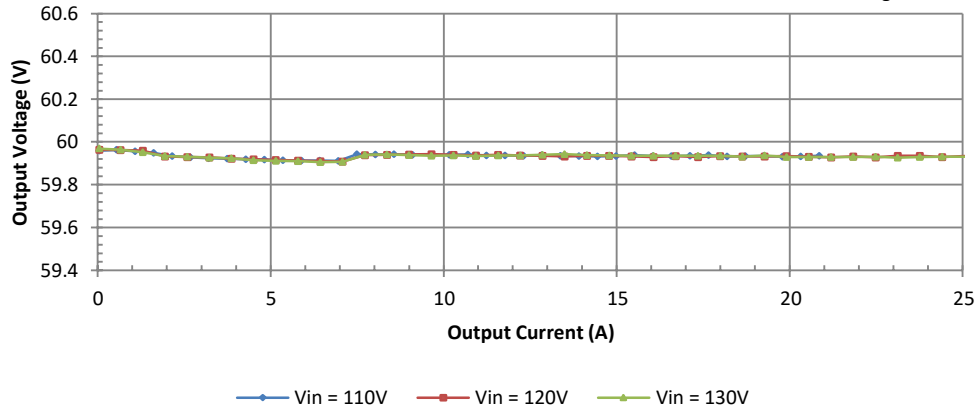

PFE1800-60 Load Regulation

Ta = -40 Deg C.

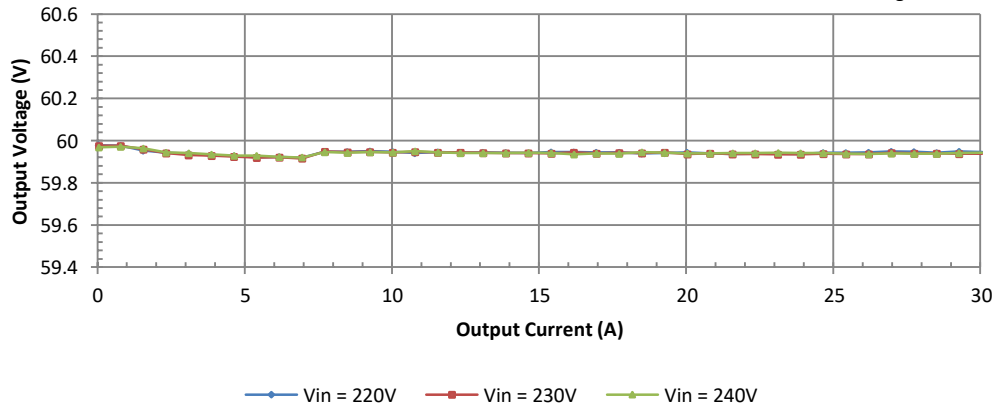

PFE1800-60 Load Regulation

Ta = -40 Deg C.

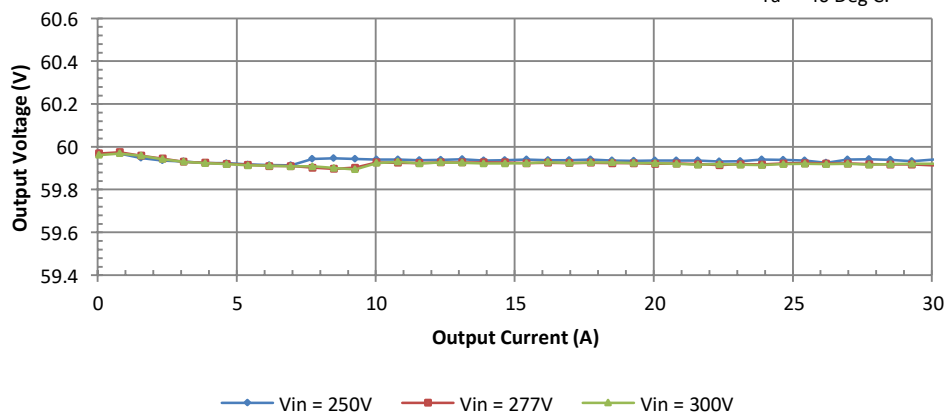

PFE1800-60 Load Regulation

Ta = 65 Deg C.

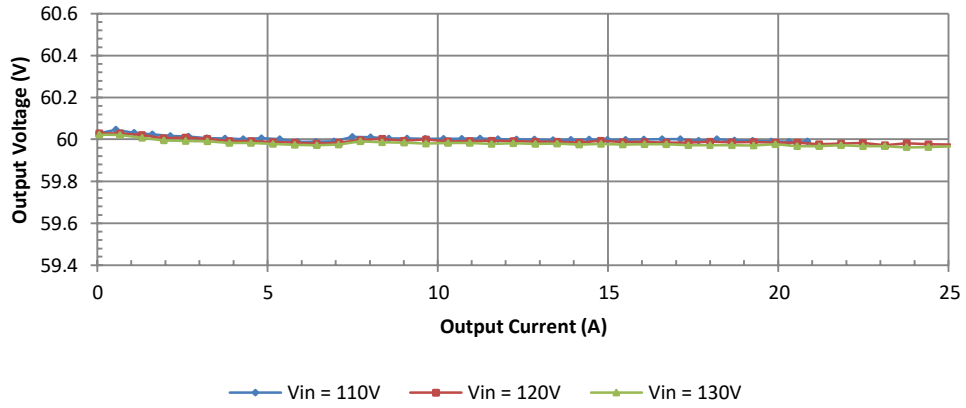

PFE1800-60 Load Regulation

Ta = 65 Deg C.

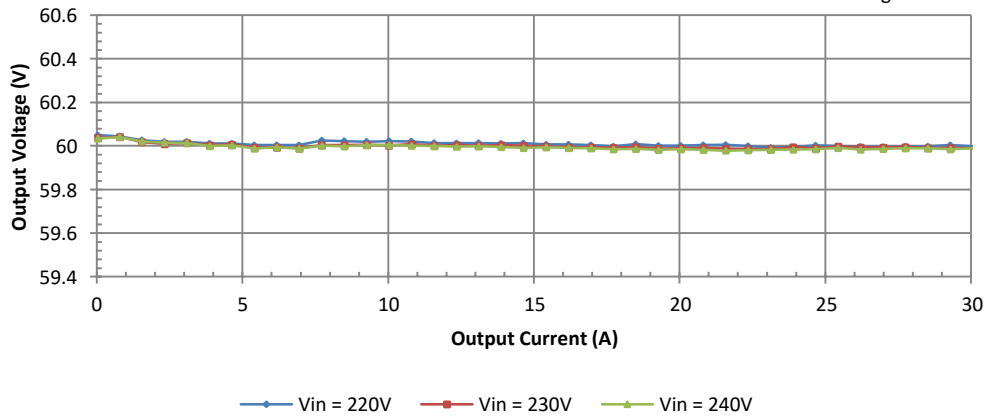

PFE1800-60 Load Regulation

Ta = 65 Deg C.

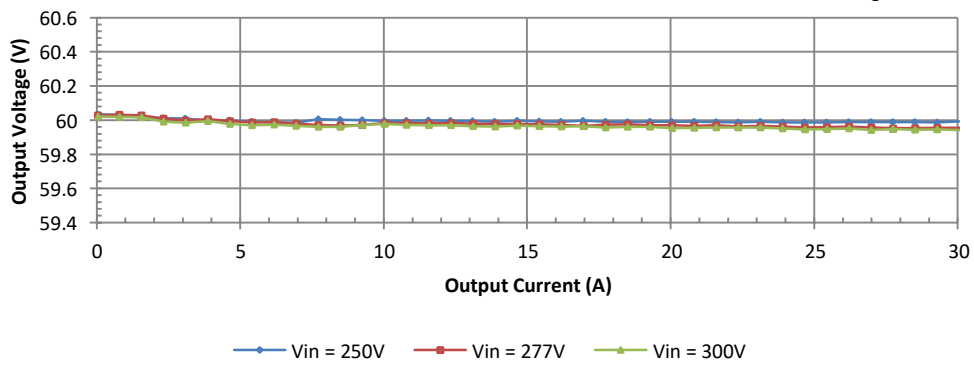

2.1.2 Efficiency vs. Output Current (60Hz)

PFE1800FB-60 Efficiency

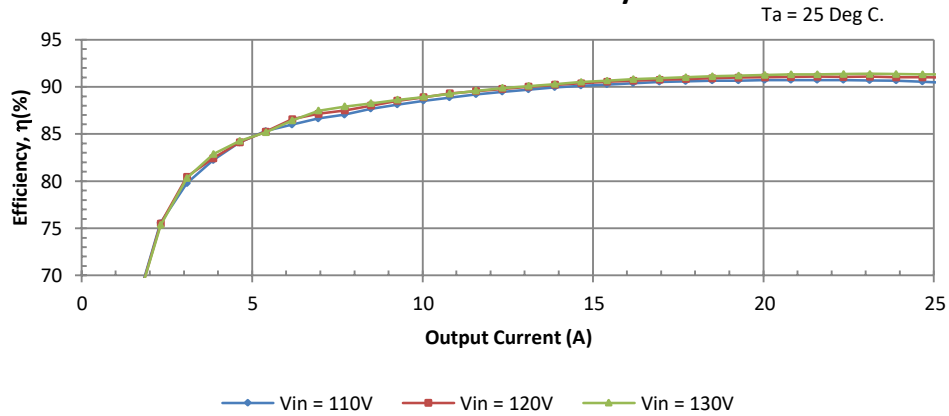

PFE1800FB-60 Efficiency

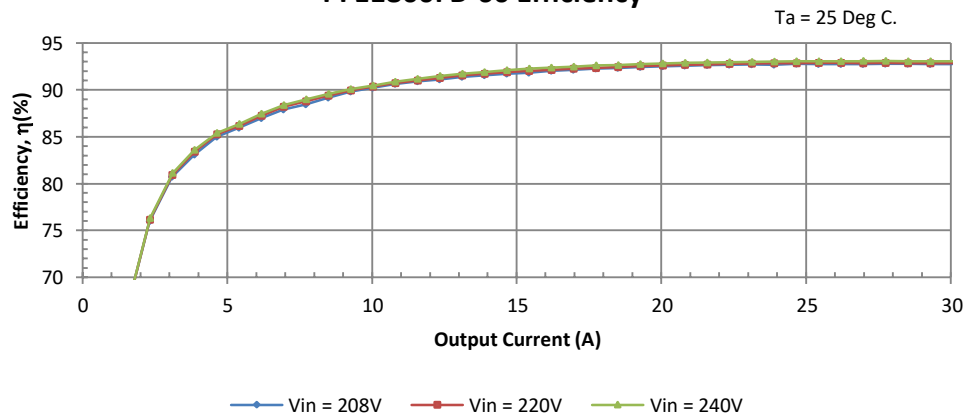

PFE1800FB-60 Efficiency

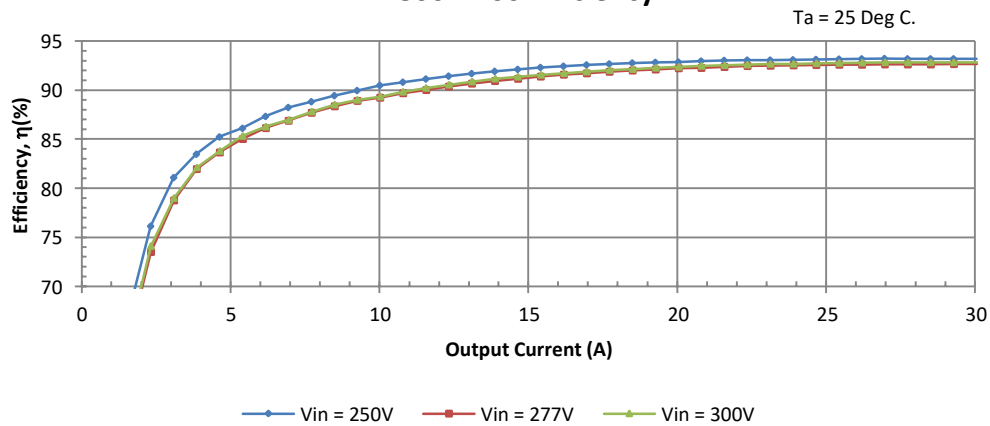

2.1.3 Power Factor (PF) vs. Input Voltage (60Hz)

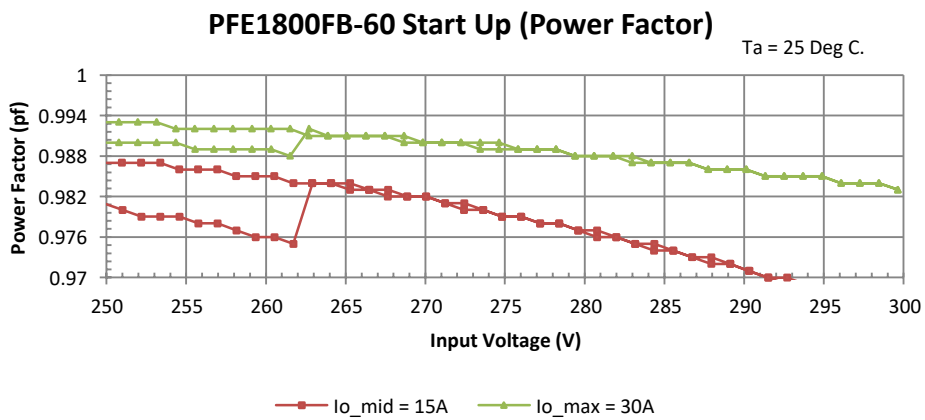
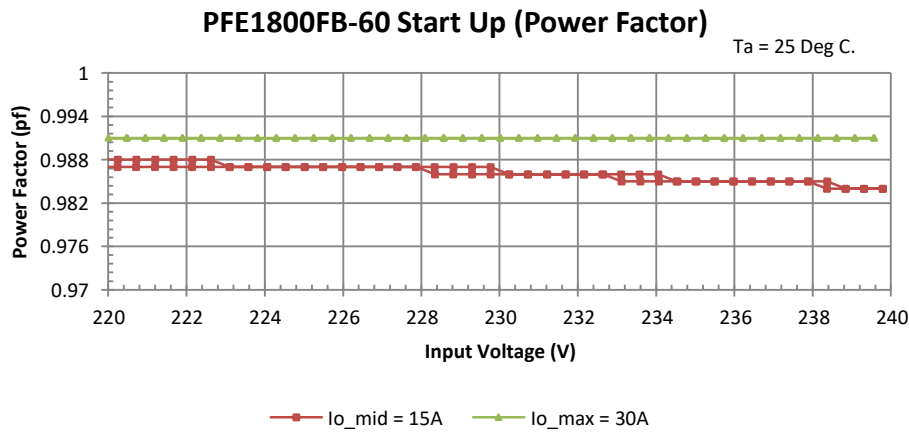
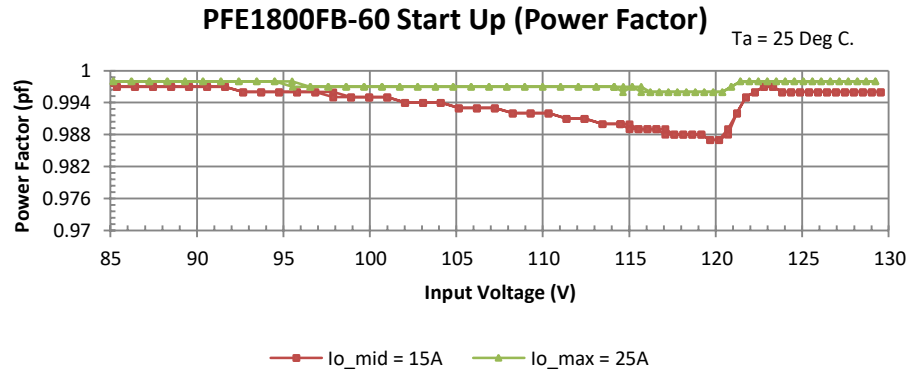

*** Power Factor Hysteresis Loop due to change in Bus Voltage around Vin=255Vac.**

2.1.4 Output behavior with input line sweep (60Hz)

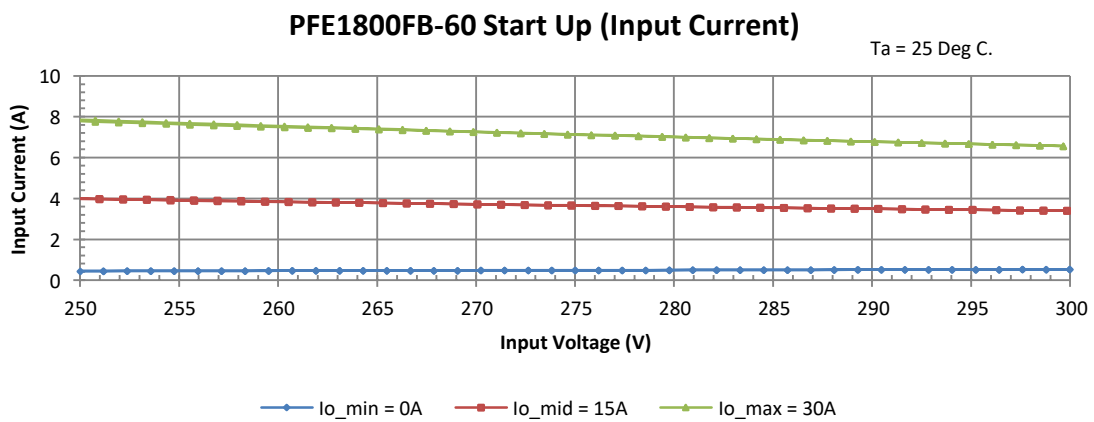
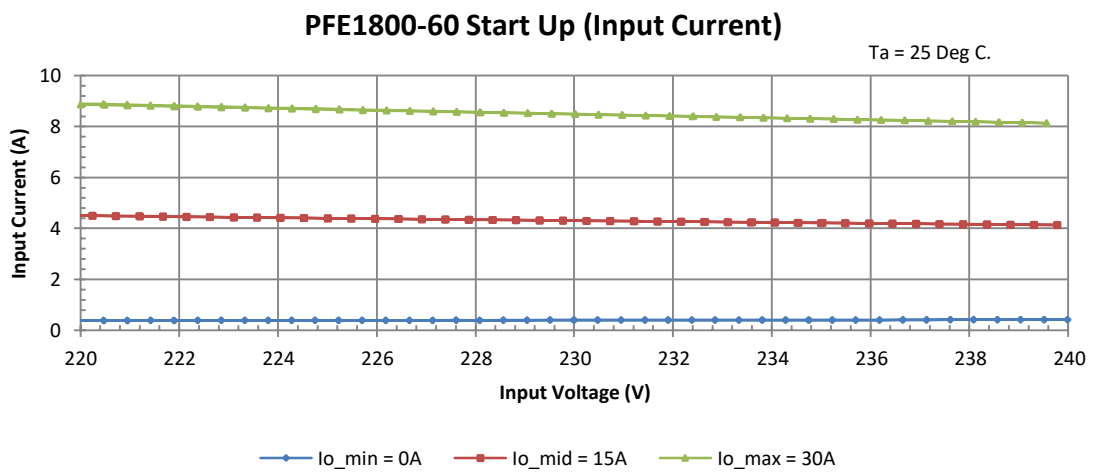
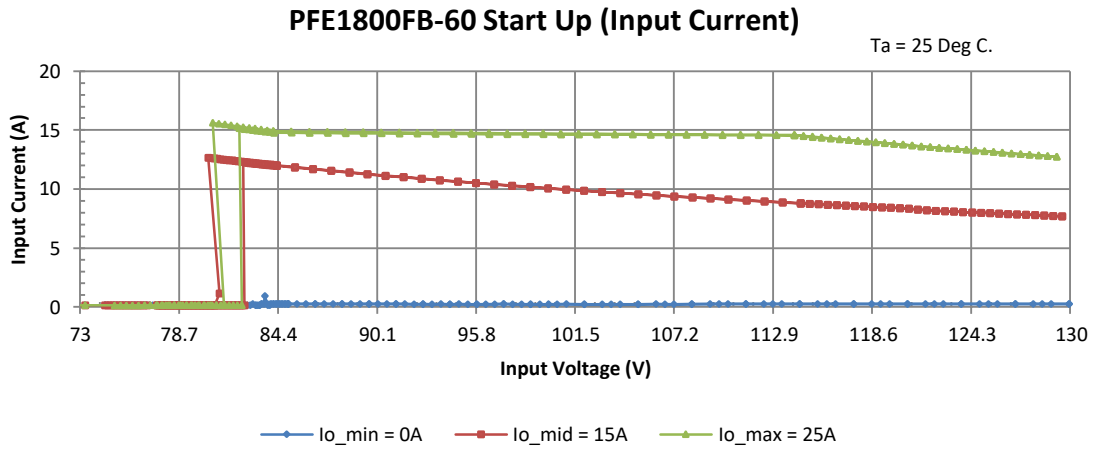

Over Current Protection (OCP) Characteristics (Refer to section 1.1.2 for Test Setup) (60Hz)

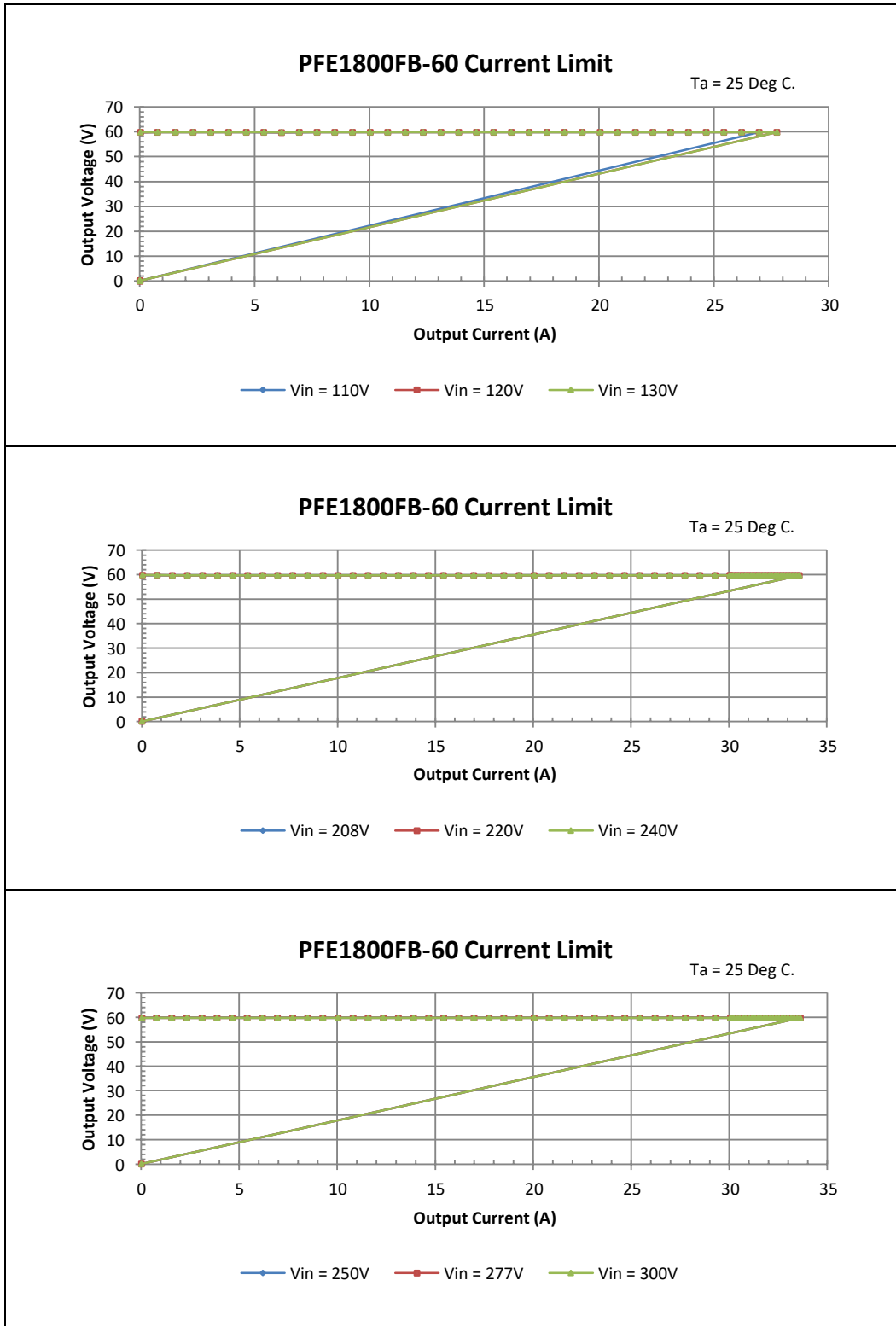

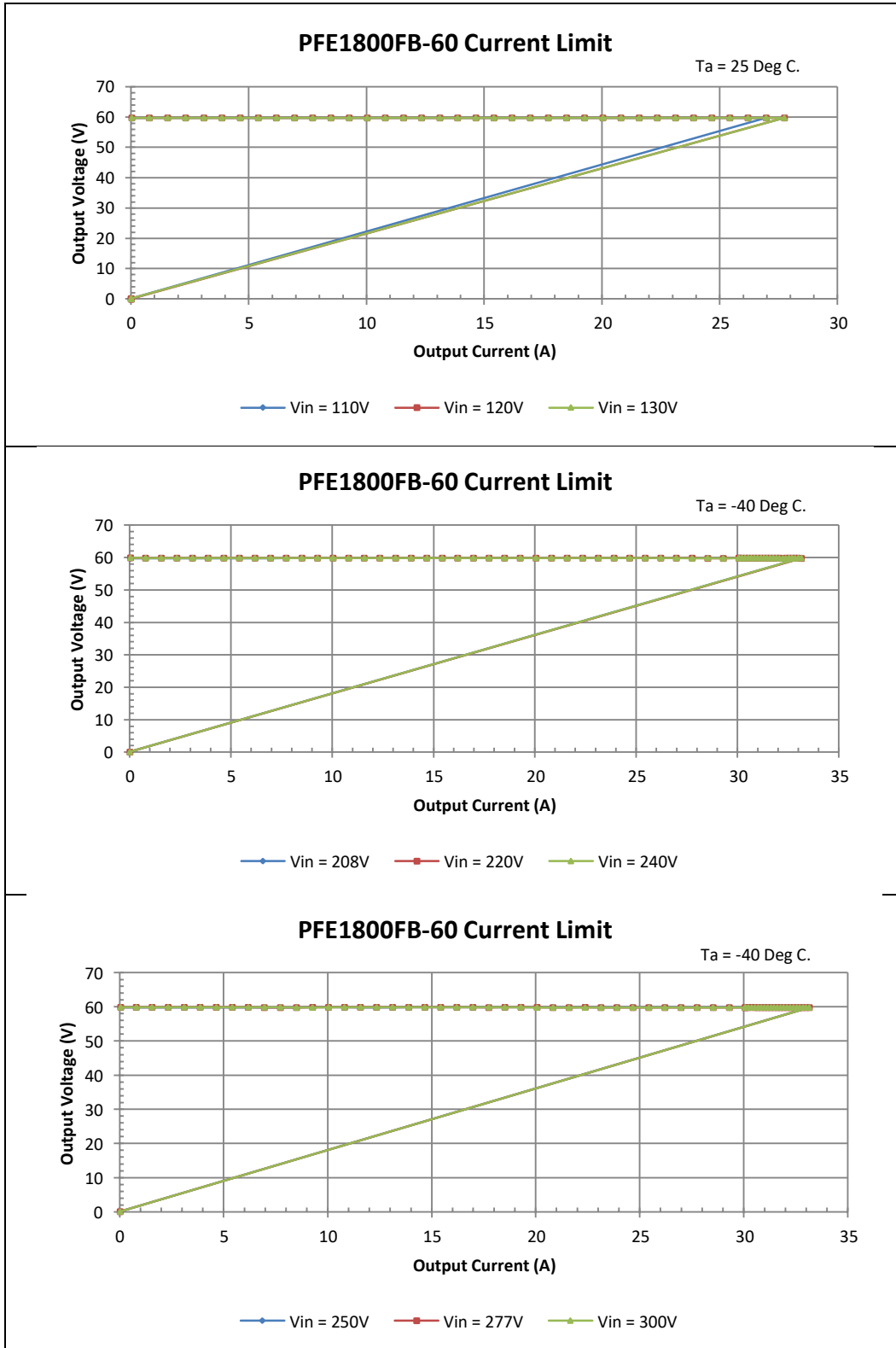

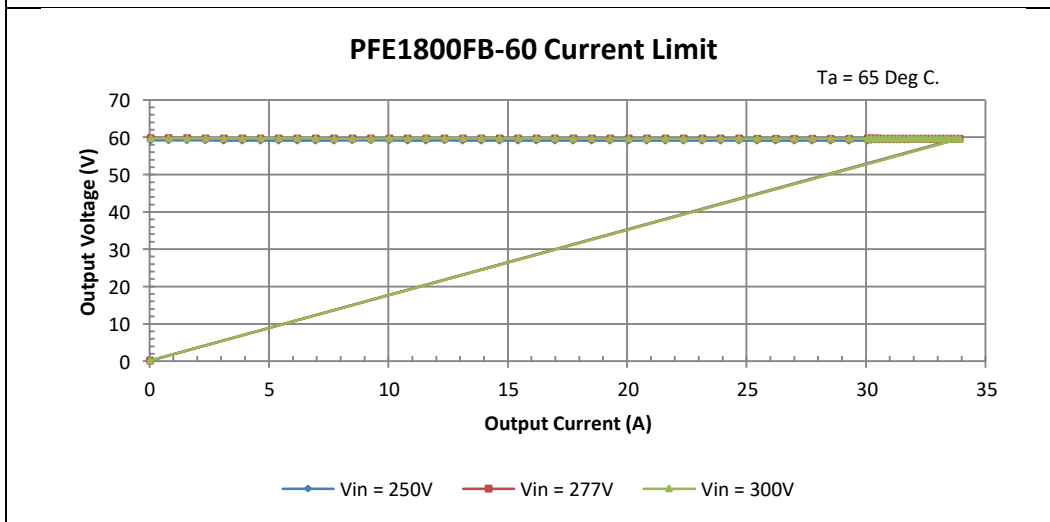
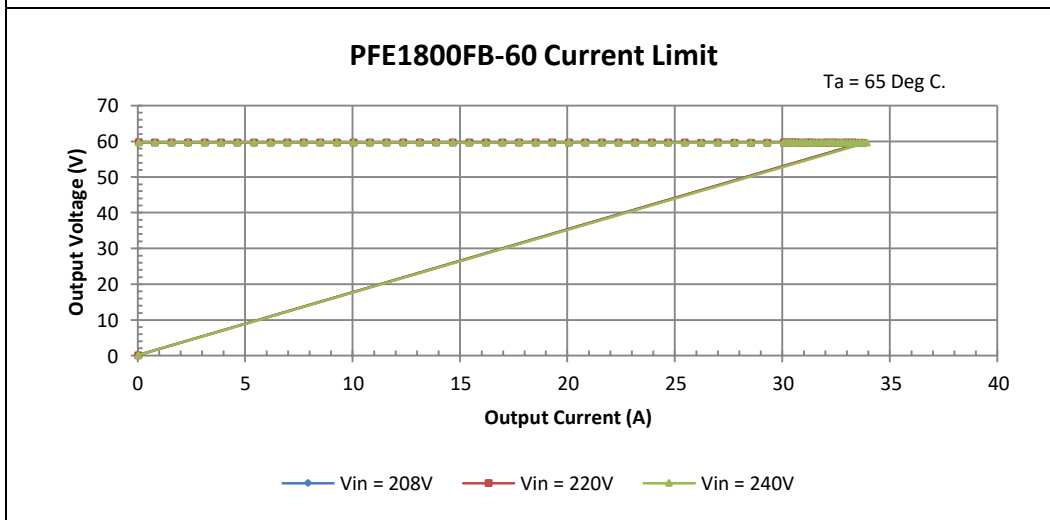
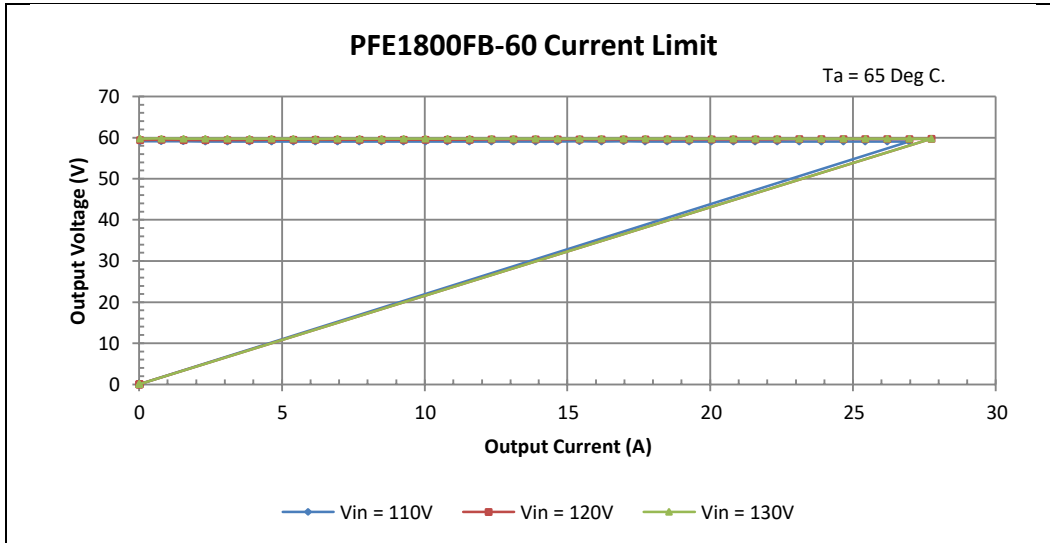

2.2 Over Voltage Protection (OVP) Characteristics (Refer to Section 1.1.2 for Test Setup)

Conditions: OVP Set Point = 62V	$I_O = 4A$
	$T_a = 25\text{ }^\circ\text{C}$
	$V_{IN} = 115\text{ VAC}$

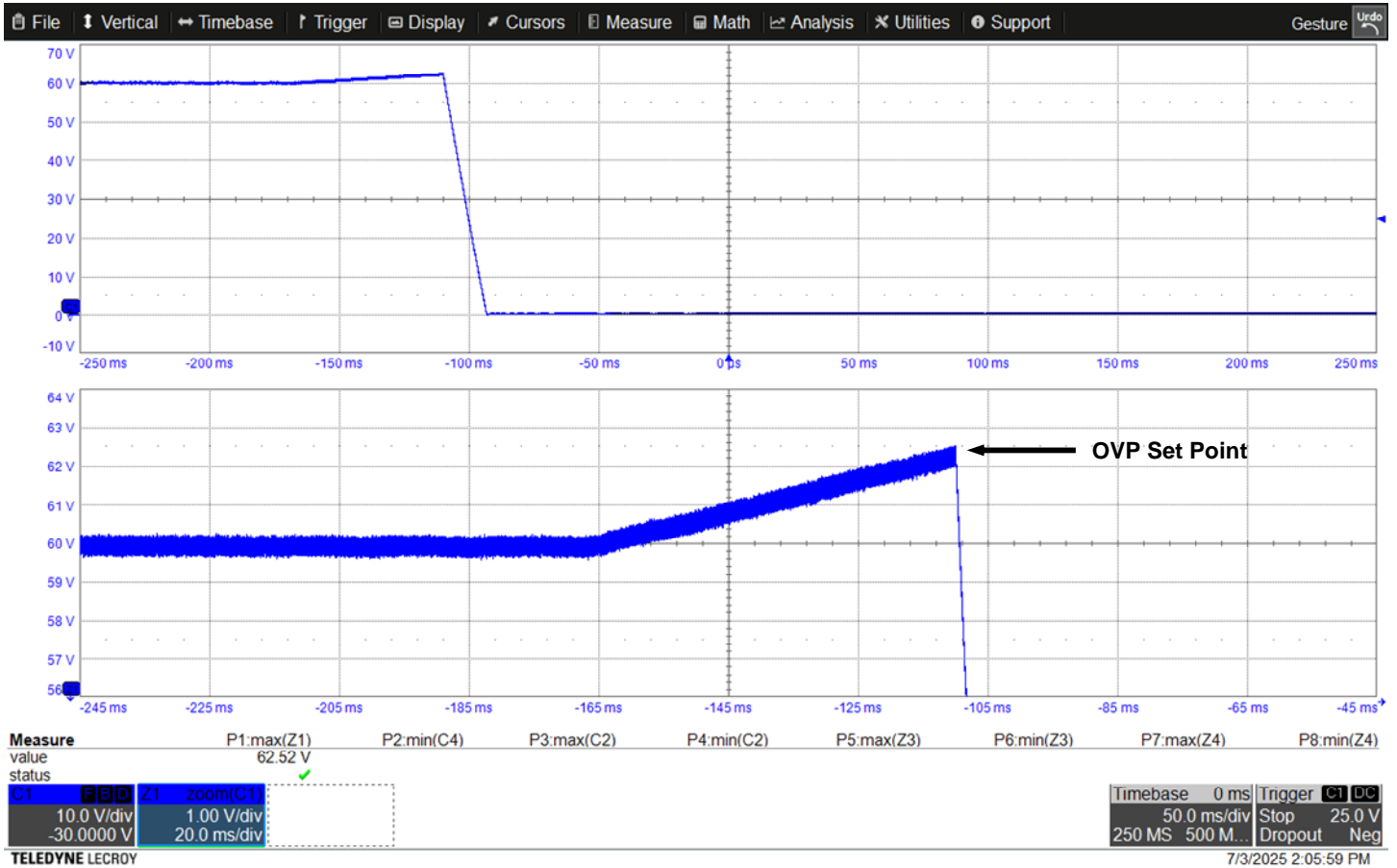

2.3 Output Rise and Fall Characteristic with AC Turn On

CH1: AC line at fixture input, CH2: AC input current, CH3: Vbus, CH4: Vout

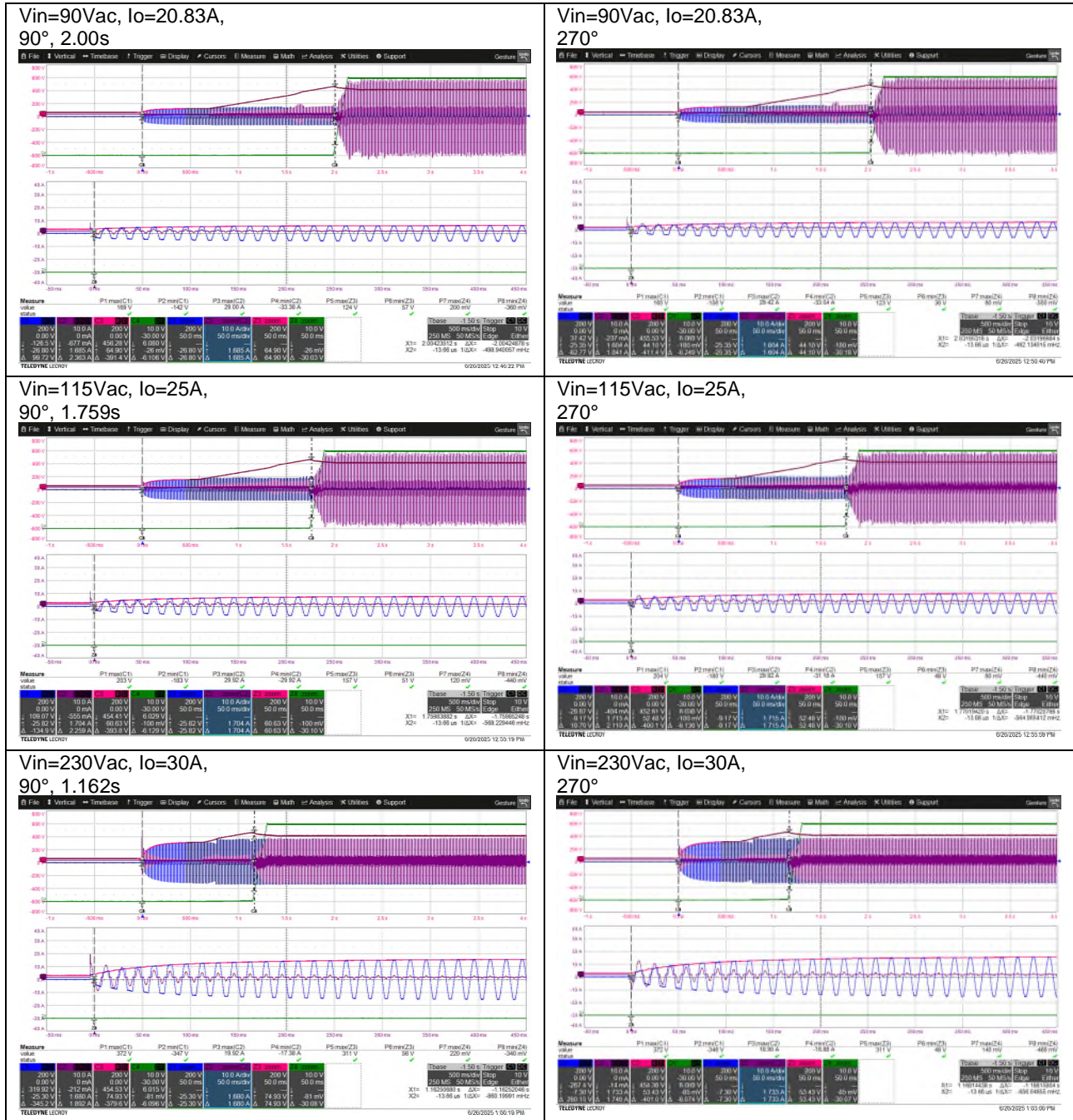

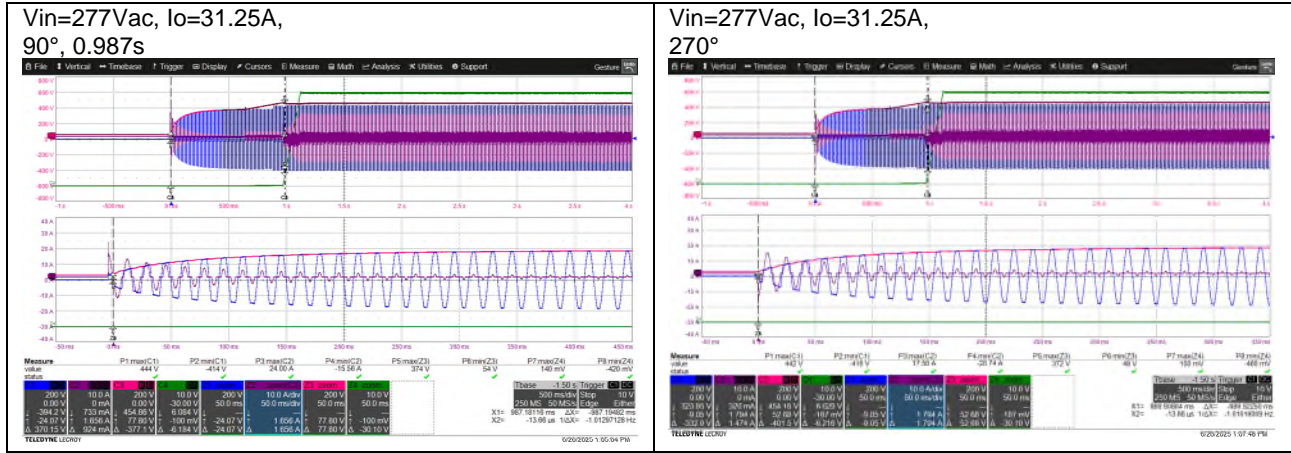

2.4 Hold Up Time Characteristic

CH1: AC line at fixture input, CH2: AC input current, CH3: Vbus, CH4: Vout

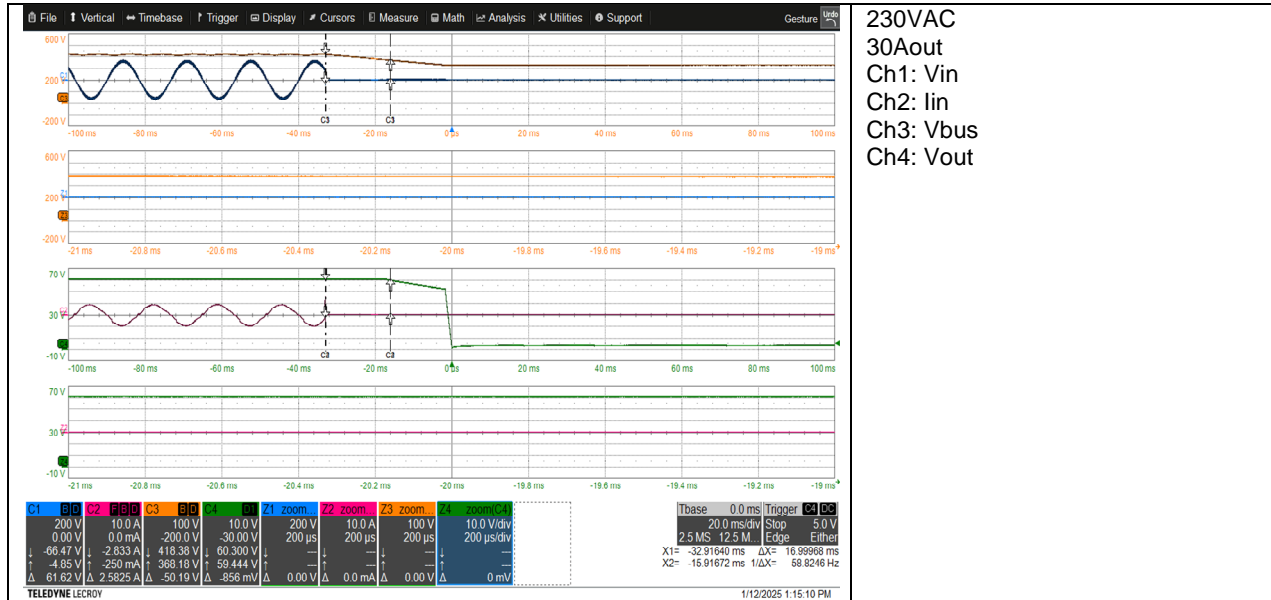

2.5 Dynamic Load Response

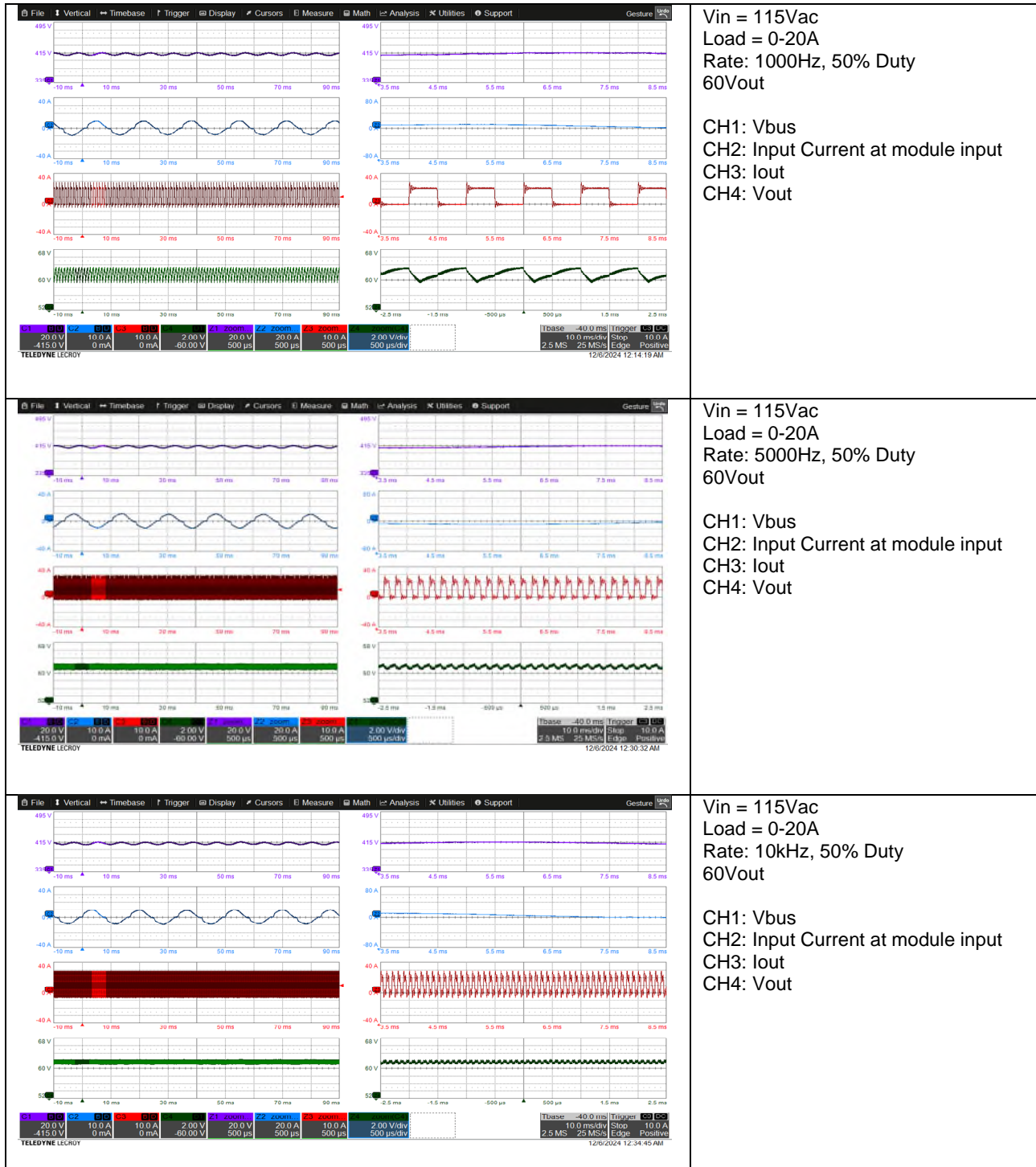

2.6 Input Current Waveform

$V_{IN} = 115 \text{ VAC } 60\text{Hz}; I_O = 25\text{A}$
CH2: V_{IN} ; CH3: I_{IN}

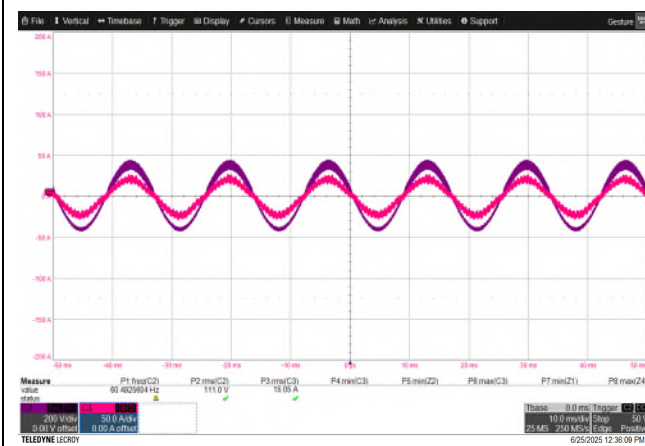

Current (THD = 5.87%) (PF = 0.996)

$V_{IN} = 230 \text{ VAC } 60\text{Hz}; I_O = 30.00\text{A}$
CH2: V_{IN} ; CH3: I_{IN}

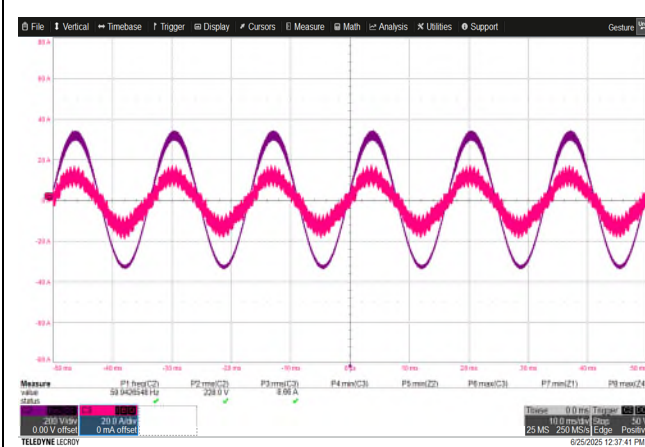

Current (THD = 7.82%) (PF = 0.991)

2.7 Input Current Harmonics

120VAC, 60Hz, 20.83Aout

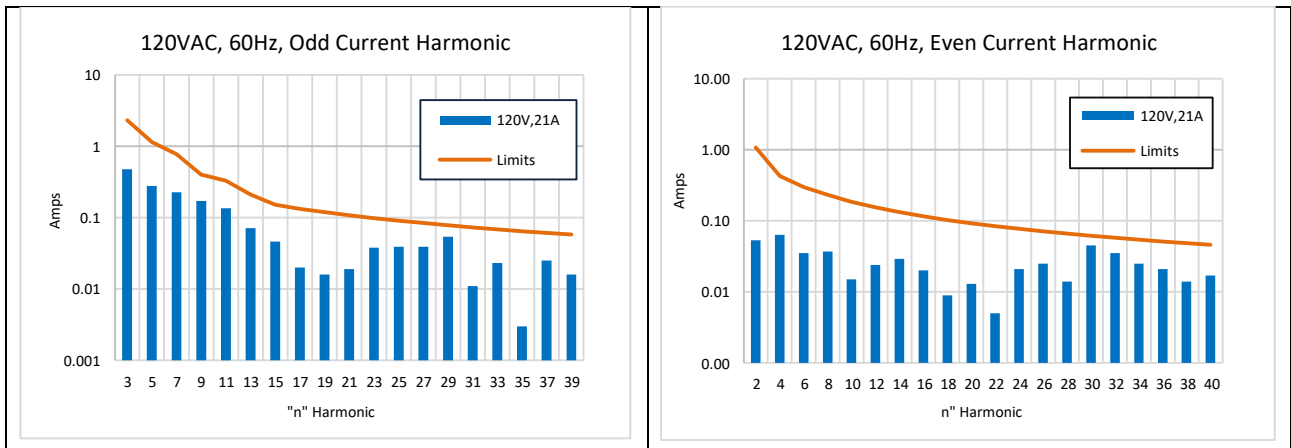

230VAC, 60Hz, 30Aout

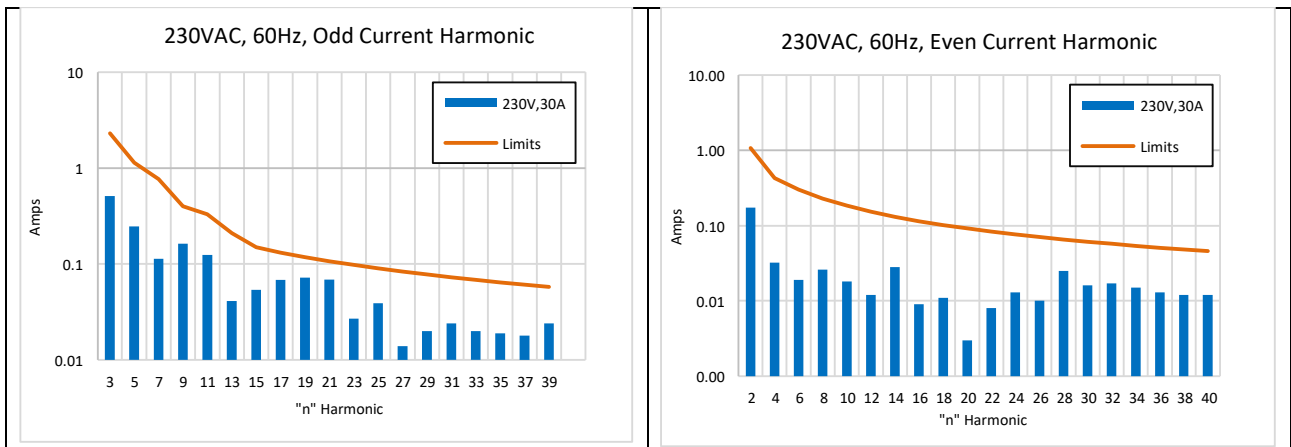

2.8 Input Inrush Current

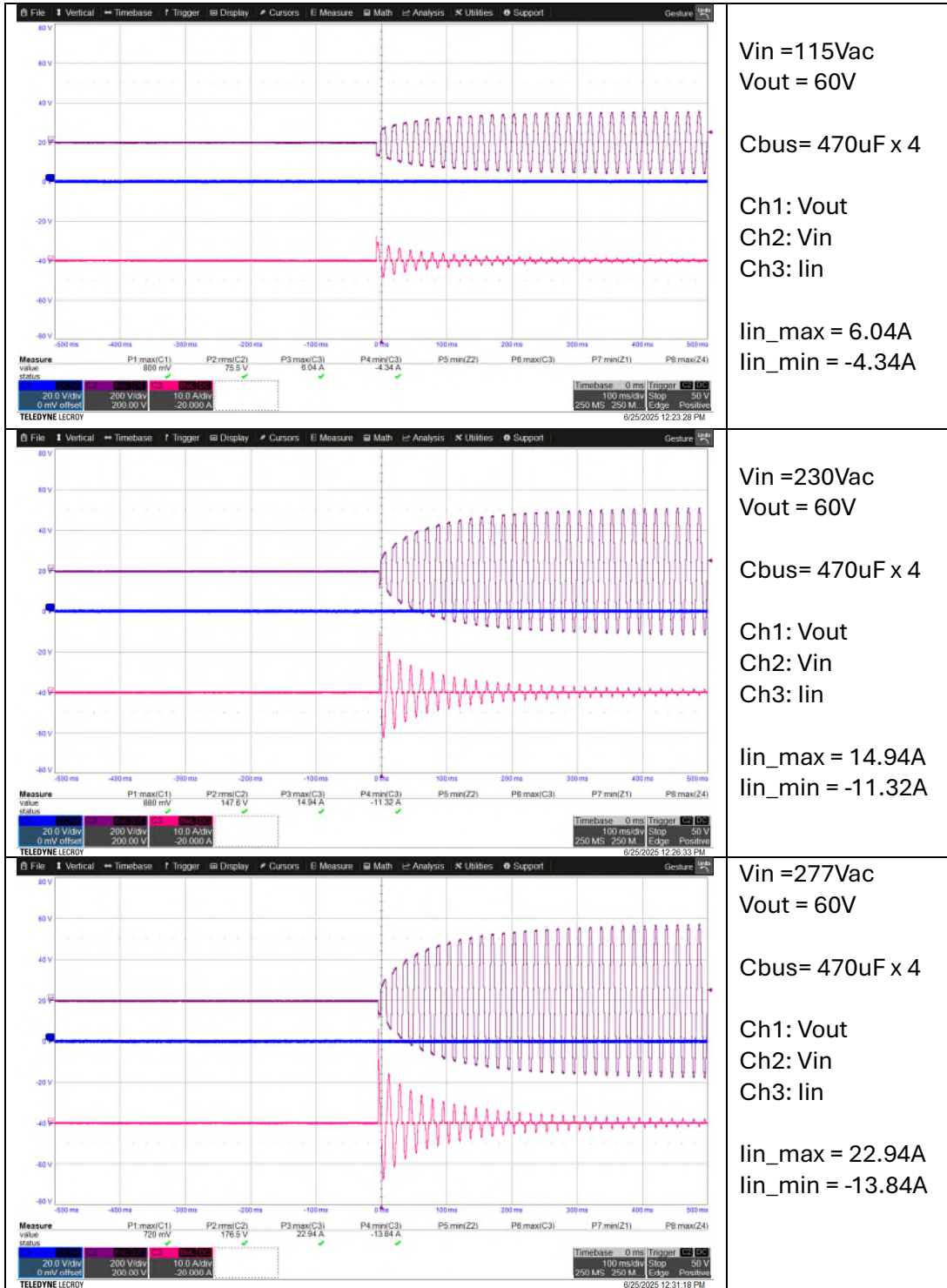

Vin = 115Vac
Vout = 60V
Cbus = 470uF x 4
Ch1: Vout
Ch2: Vin
Ch3: Iin
Iin_max = 6.04A
Iin_min = -4.34A

Vin = 230Vac
Vout = 60V
Cbus = 470uF x 4
Ch1: Vout
Ch2: Vin
Ch3: Iin
Iin_max = 14.94A
Iin_min = -11.32A

Vin = 277Vac
Vout = 60V
Cbus = 470uF x 4
Ch1: Vout
Ch2: Vin
Ch3: Iin
Iin_max = 22.94A
Iin_min = -13.84A

2.9 Brownout Data

Vout = 60V

Hardware: Open-frame, Vbus 4*470uF (electrolytic cap), Output 5*220uF (electrolytic cap) 8*4.7uF ceramic cap.

Results table

A = criteria A - DUT operates within specification limits during and after test.

B = criteria B - DUT exhibits a change in performance when operating then self-recovered.

A/B = some are criteria A or criteria B based on start angle

A* = criteria A, but due to derate at low Vrms, either resistive load or foldback must be used. Otherwise, criteria B.

	50Hz			60Hz		
	115VAC	230VAC	277VAC	115VAC	230VAC	277VAC
70% VAC, 0.5 cycle	A	A	A	A	A	A
40% VAC, 25 cycle	B	B	B	B	B	B
0% VAC, 250/300 cycles	B	B	B	B	B	B
0% VAC, 0.5 cycle	A	A/B	A	A	A	A
0% VAC, 1 cycle	B	B	A/B	B	B	A
40% VAC, 10 cycles	B	B	B	B	B	B
70% VAC, 25 cycles	B	A	A	B	A	A
80% VAC, 250 cycles	A*	A	A	A*	A	A
0% VAC, 250 cycles	B	B	B	B	B	B

2.11 Output Ripple and Noise

$T_a = 25\text{ }^\circ\text{C}$

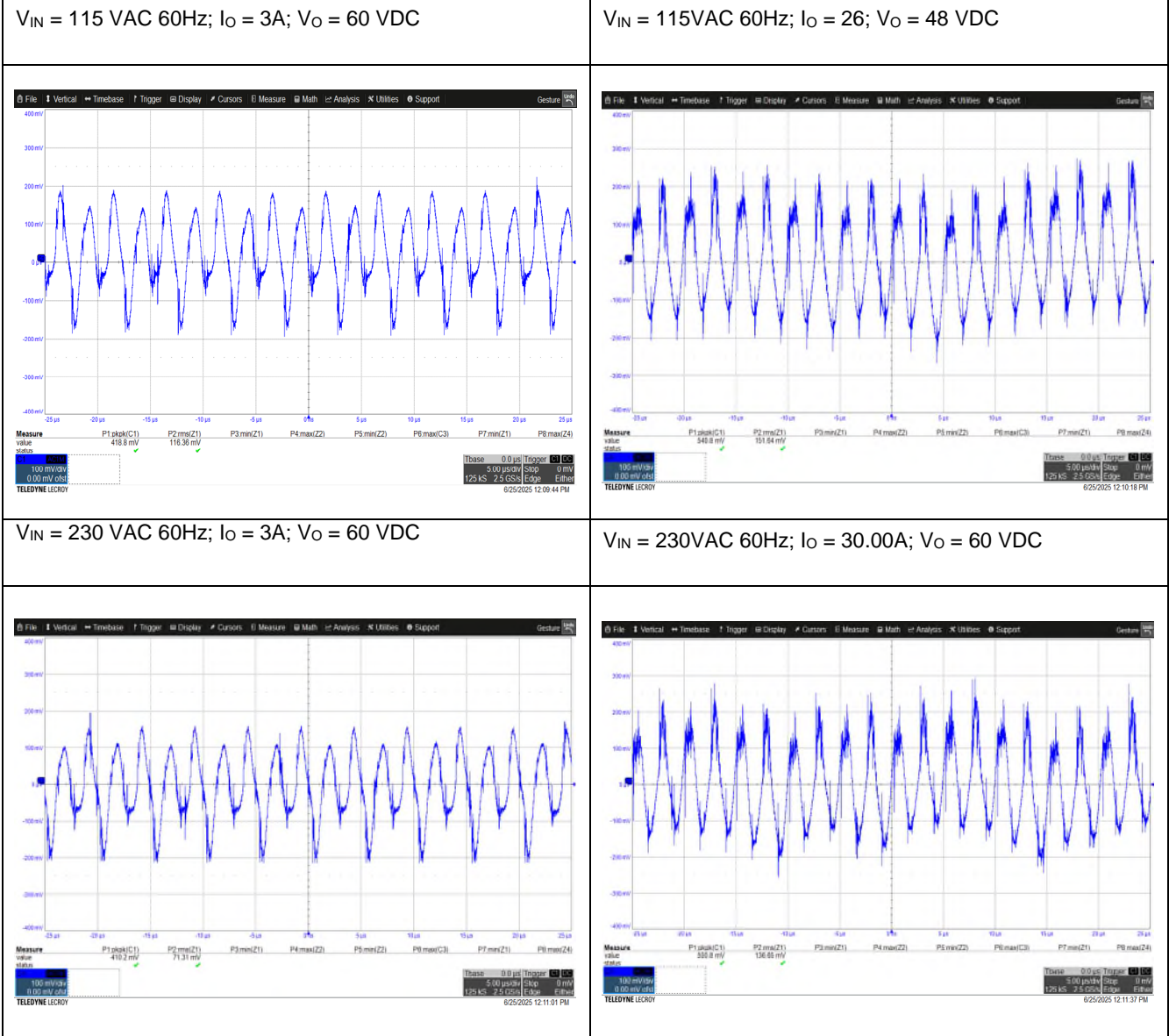

Information furnished by TDK-Lambda is believed to be accurate and reliable. However, TDK-Lambda assumes no responsibility for its use, nor for any infringement of patents or other rights of third parties, which may result from its use. No license is granted by implication or otherwise under any patent or patent rights of TDK-Lambda. TDK components are not designed to be used in applications, such as life support systems, wherein failure or malfunction could result in injury or death. All sales are subject to TDK-Lambda's Terms and Conditions of Sale, which are available upon request. Specifications are subject to change without notice.

TDK-Lambda



TDK-Lambda France SAS
Tel: +33 1 60 12 71 65
france@fr.tdk-lambda.com
www.emea.lambda.tdk.com/fr



Italy Sales Office
Tel: +39 02 61 29 38 63
info.italia@it.tdk-lambda.com
www.emea.lambda.tdk.com/it



Netherlands
info@nl.tdk-lambda.com
www.emea.lambda.tdk.com/nl



TDK-Lambda Germany GmbH
Tel: +49 7841 666 0
info.germany@de.tdk-lambda.com
www.emea.lambda.tdk.com/de



Austria Sales Office
Tel: +43 2256 655 84
info@at.tdk-lambda.com
www.emea.lambda.tdk.com/at



Switzerland Sales Office
Tel: +41 44 850 53 53
info@ch.tdk-lambda.com
www.emea.lambda.tdk.com/ch



Nordic Sales Office
Tel: +45 8853 8086
info@dk.tdk-lambda.com
www.emea.lambda.tdk.com/dk



TDK-Lambda UK Ltd.
Tel: +44 (0) 12 71 85 66 66
powersolutions@uk.tdk-lambda.com
www.emea.lambda.tdk.com/uk



TDK-Lambda Ltd.
Tel: +9 723 902 4333
info@tdk-lambda.co.il
www.emea.lambda.tdk.com/il



C.I.S.
Commercial Support:
Tel: +7 (495) 665 2627
Technical Support:
Tel: +7 (812) 658 0463
info@tdk-lambda.ru
www.emea.lambda.tdk.com/ru



TDK-Lambda Americas
Tel: +1 800-LAMBDA-4 or 1-800-526-2324
powersolutions@us.tdk-lambda.com
www.us.lambda.tdk.com



TDK Electronics do Brasil Ltda
Tel: +55 11 3289-9599
sales.br@tdk-electronics.tdk.com
www.tdk-electronics.tdk.com/en



TDK-Lambda Corporation
Tel: +81-3-6778-1113
www.jp.lambda.tdk.com



TDK-Lambda (China) Electronics Co. Ltd.
Tel: +86 21 6485-0777
powersolutions@cn.tdk-lambda.com
www.lambda.tdk.com.cn



TDK-Lambda Singapore Pte Ltd.
Tel: +65 6251 7211
tts.mkt@sg.tdk-lambda.com
www.sg.lambda.tdk.com



TDK India Private Limited, Power Supply Division
Tel: +91 80 4039-0660
mathew.philip@in.tdk-lambda.com
www.sg.lambda.tdk.com

