

ZWS300RC

EVALUATION DATA

型式データ

INDEX

PAGE

1. 測定方法 Evaluation Method	
1-1. 測定回路 Circuit used for determination	4
測定回路1 Circuit 1 used for determination	
静特性 Steady state data	
通電ドリフト特性 Warm up voltage drift characteristics	
出力保持時間特性 Hold up time characteristics	
出力立ち上がり特性 Output rise characteristics	
出力立ち下がり特性 Output fall characteristics	
過電流保護特性 Over current protection (OCP) characteristics	
過電圧保護特性 Over voltage protection (OVP) characteristics	
過渡応答(入力急変)特性 Dynamic line response characteristics	
入力電圧瞬停特性 Response to brown out characteristics	
入力電流波形 Input current waveform	
測定回路2 Circuit 2 used for determination	4
過渡応答(負荷急変)特性 Dynamic load response characteristics	
測定回路3 Circuit 3 used for determination	5
入力サージ電流(突入電流)波形 Inrush current waveform	
測定回路4 Circuit 4 used for determination	5
リーク電流特性 Leakage current characteristics	
測定回路5 Circuit 5 used for determination	5
ON/OFFコントロール時立ち上がり、立ち下がり特性	
Output rise, fall characteristics with ON/OFF Control	
測定回路6 Circuit 5 used for determination	6
出力リップル、ノイズ波形 Output ripple and noise waveform	
測定構成 Configuration used for determination	6
EMI特性 Electro-Magnetic Interference characteristics	
(a) 雑音端子電圧(帰還ノイズ) Conducted Emission	
(b) 雑音電界強度(放射ノイズ) Radiated Emission	
1-2. 使用測定機器 List of equipment used	7
1-3. 評価負荷条件 Load conditions	7

2. 特性データ Characteristics

2-1. 静特性 Steady state data	
(1) 入力・負荷・温度変動／出力起動・遮断電圧 Regulation - line and load, Temperature drift / Start up voltage and Drop out voltage	8
(2) リップルノイズ電圧対入力電圧 Ripple noise voltage vs. Input voltage	8
(3) 効率・力率対出力電流 Efficiency and Power factor vs. Output current	9
(4) 入力電力対出力電流 Input power vs. Output current	9
(5) 入力電流対出力電流 Input current vs. Output current	10
2-2. 通電ドリフト特性 Warm up voltage drift characteristics	11
2-3. 出力保持時間特性 Hold up time characteristics	11
2-4. 出力立ち上がり特性 Output rise characteristics	12
2-5. 出力立ち下がり特性 Output fall characteristics	13
2-6. ON/OFFコントロール時出力立ち上がり、立ち下がり特性 (*) Output rise, fall characteristics with ON/OFF Control	14
標準品 ZWS300RC-/R にて対応 For option model ZWS300RC-*/R	
2-7. 過電流保護特性 Over current protection (OCP) characteristics	15
2-8. 過電圧保護特性 Over voltage protection (OVP) characteristics	15
2-9. 過渡応答(入力急変)特性 Dynamic line response characteristics	16
2-10. 過渡応答(負荷急変)特性 Dynamic load response characteristics	16
2-11. 入力電圧瞬停特性 Response to brown out characteristics	17
2-12. 入力サージ電流(突入電流)波形 Inrush current waveform	18
2-13. 高調波成分 Input current harmonics	19
2-14. 入力電流波形 Input current waveform	19
2-15. リーク電流特性 Leakage current characteristics	20
2-16. 出力リップル、ノイズ波形 Output ripple and noise waveform	21
2-17. EMI特性 Electro-Magnetic Interference characteristics	22~23

■使用記号 Terminology used

定義 Definition

V _{in}	入力電圧 Input voltage
V _{out}	出力電圧 Output voltage
I _{in}	入力電流 Input current
I _{out}	出力電流 Output current
T _a	周囲温度 Ambient temperature
f	周波数 Frequency

■試験結果は、当社測定条件における結果であり、参考値としてお考え願います。

Test results are reference data based on our measurement condition.

1. 測定方法 Evaluation Method

1-1. 測定回路 Circuit used for determination

測定回路1 Circuit 1 used for determination

- 静特性 Steady state data
- 通電ドリフト特性 Warm up voltage drift characteristics
- 出力保持時間特性 Hold up time characteristics
- 出力立ち上がり特性 Output rise characteristics
- 出力立ち下がり特性 Output fall characteristics
- 過電流保護特性 Over current protection (OCP) characteristics
- 過電圧保護特性 Over voltage protection (OVP) characteristics
- 過渡応答(入力急変)特性 Dynamic line response characteristics
- 入力電圧瞬停特性 Response to brown out characteristics
- 入力電流波形 Input current waveform

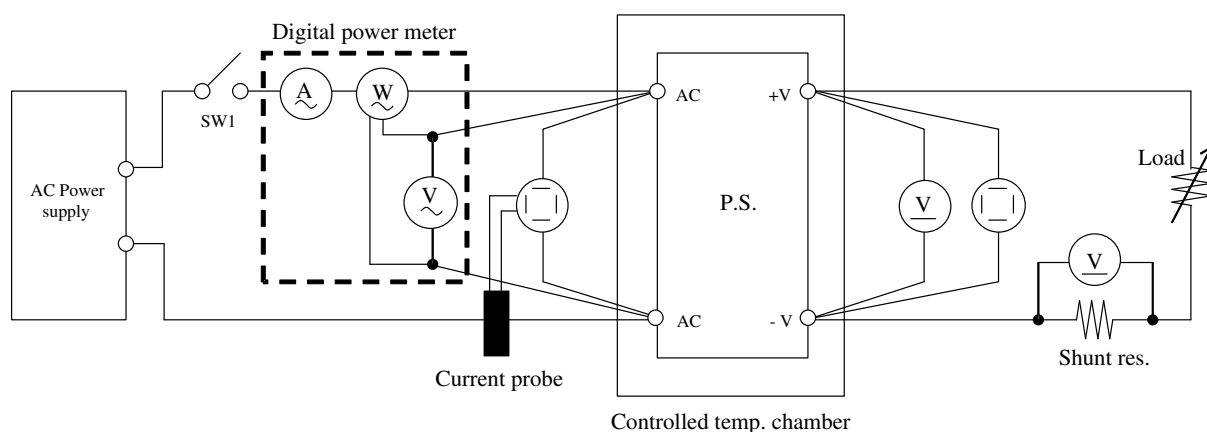

測定回路2 Circuit 2 used for determination

- 過渡応答(負荷急変)特性 Dynamic load response characteristics

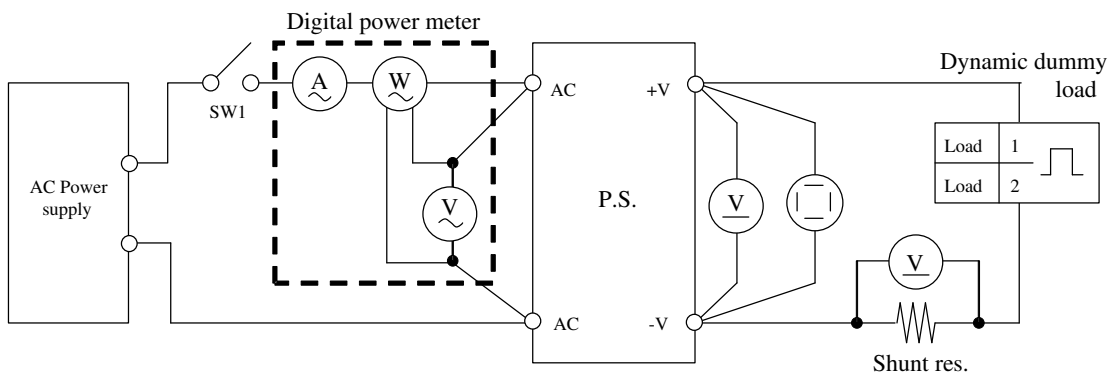

Output current waveform
 $I_{out} 50\% \iff 100\%$

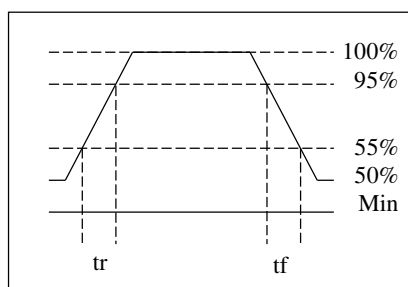

測定回路3 Circuit 3 used for determination

- 入力サージ電流 (突入電流) 波形 Inrush current waveform

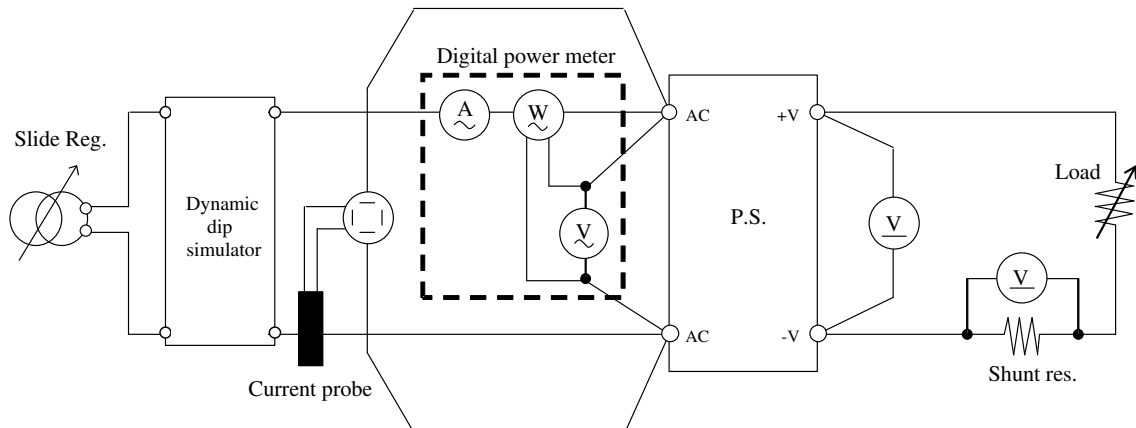

測定回路4 Circuit 4 used for determination

- リーク電流特性 Leakage current characteristics

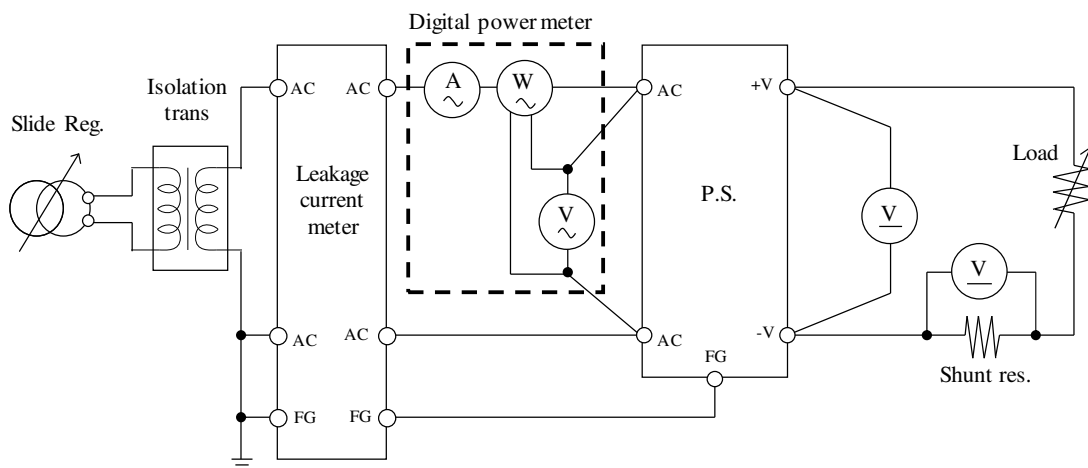

測定回路5 Circuit 54 used for determination

- ON/OFFコントロール時出力立ち上がり、立ち下がり特性
Output rise, fall characteristics with ON/OFF Control

準標準品 ZWS300RC-*/R にて対応 For alternative standard model ZWS300RC-*/R

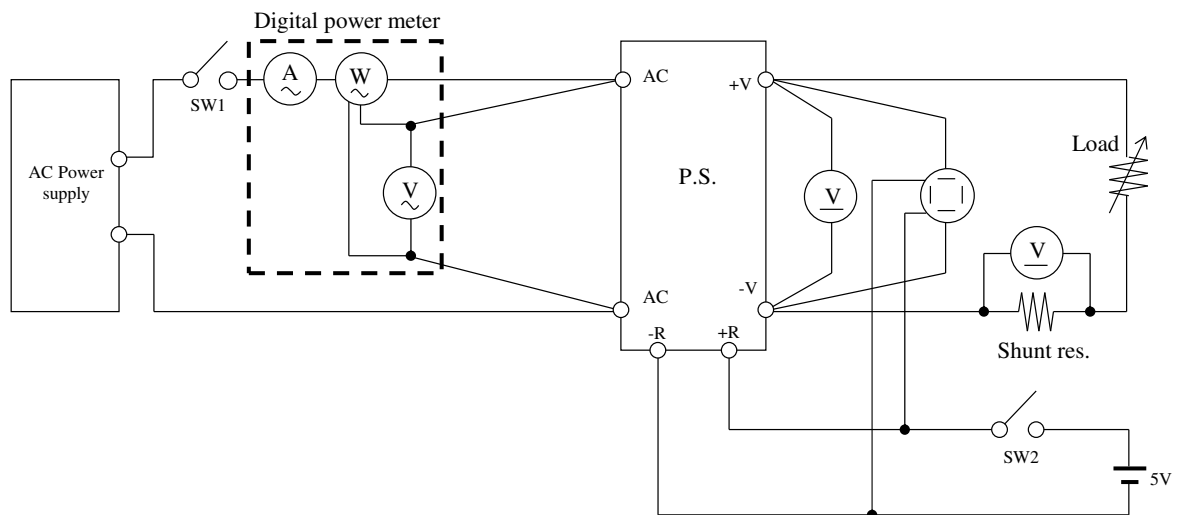

測定回路6 Circuit 5 used for determination

- 出力リップル、ノイズ波形 Output ripple and noise waveform

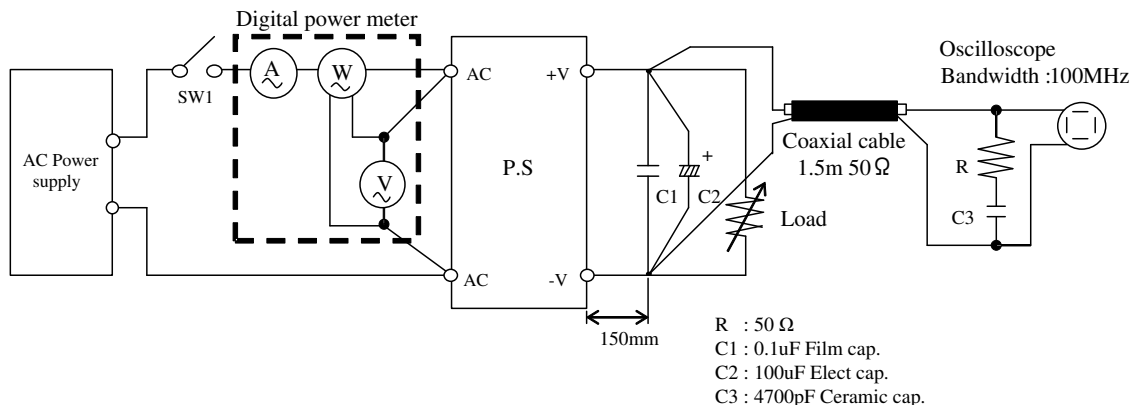

測定構成 Configuration used for determination

- EMI特性 Electro-Magnetic Interference characteristics

(a) 雑音端子電圧 (帰還ノイズ) Conducted Emission

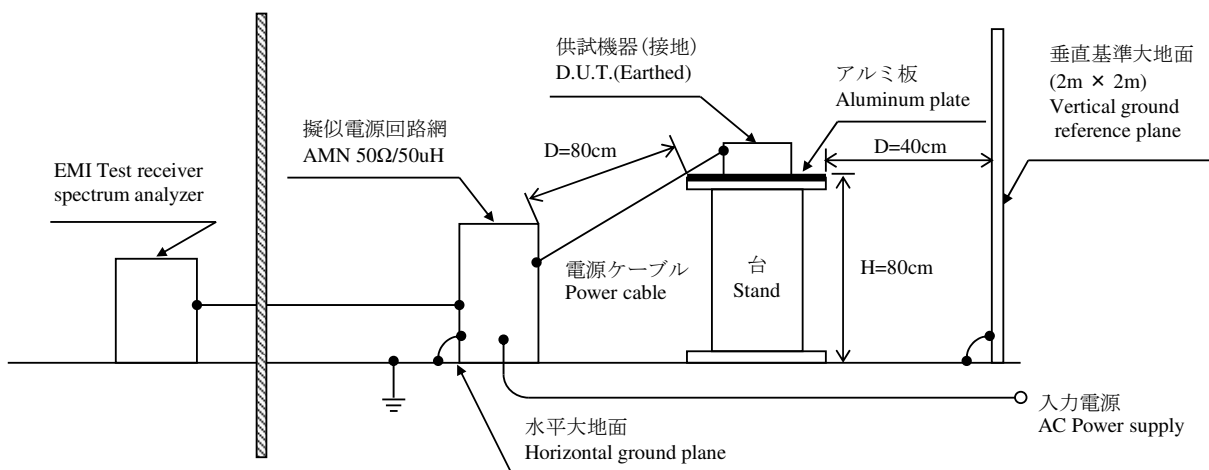

(b) 雑音電界強度 (放射ノイズ) Radiated Emission

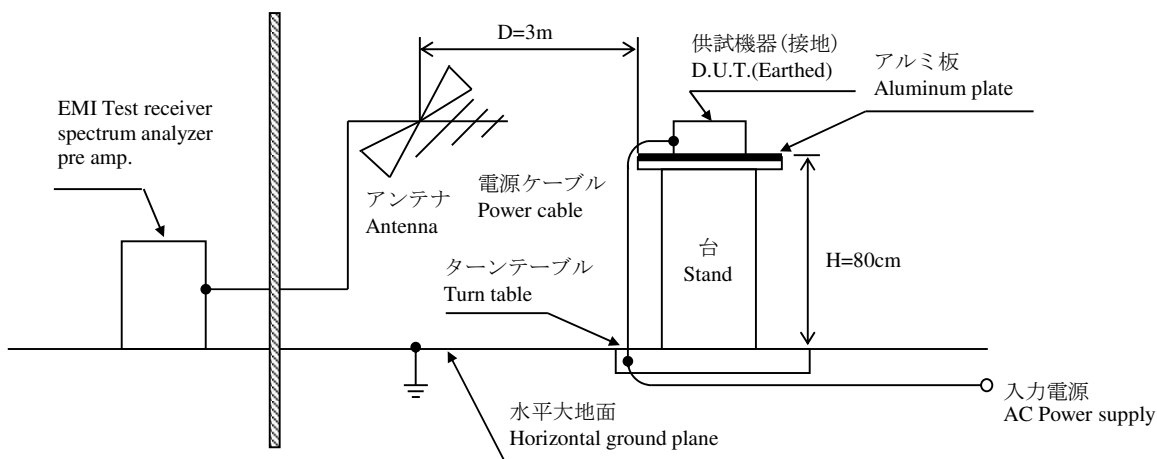

1-2. 使用測定機器 List of equipment used

	EQUIPMENT USED	MANUFACTURER	MODEL NO.
1	DIGITAL STORAGE OSCILLOSCOPE	YOKOGAWA ELECT.	DL9040L / DLM1740
2	DIGITAL MULTIMETER	AGILENT	34970A
3	DIGITAL POWER METER	YOKOGAWA ELECT.	WT210
4	CURRENT PROBE	YOKOGAWA ELECT.	701928
5	DYNAMIC DUMMY LOAD	TAKASAGO	FK-400L
6	DYNAMIC DUMMY LOAD	KIKUSUI	PLZ1004W
7	DUMMY LOAD	PCN	PHF250 SERIES
8	ISOLATION TRANS	NOISE KEN	TF-2302P
9	SLIDE REGULATOR	MATSUNAGA	S3-24100
10	SLIDE REGULATOR	MATSUNAGA	SD-2650
11	ISOLATION TRANS	MATSUNAGA	3WTC-50K
12	CVCF	TAKASAGO	AA2000XG/AA2000XG2
13	CVCF	NF	ES10000S
14	LEAKAGE CURRENT METER	HIOKI	ST5540
15	DYNAMIC DIP SIMULATOR	TAKAMISAWA	PSA-210
16	CONTROLLED TEMP. CHAMBER	ESPEC	SU-240
17	EMI TEST RECEIVER / SPECTRUM ANALYZER	ROHDE & SCHWARZ	ESCI
18	PRE AMP.	SONOMA	310N
19	AMN	SCHWARZBECK	NNLK8121
20	ANTENNA	TESEQ	CBL6111D
21	HARMONIC / FLICKER ANALYZER	KIKUSUI	KHA1000
22	SINGLE-PHASE MASTER	NF	4420
23	REFERENCE IMPEDANCE NETWORK 20A	NF	4150
24	MULTI OUTLET UNIT	KIKUSUI	OT01-KHA

1-3. 評価負荷条件 Load conditions

*入力電圧が90VAC未満の場合、下記のとおり出力ディレーティングが必要です。

出力ディレーティングについての詳細は、仕様書の「LOAD vs INPUT VOLTAGE」をご参照ください。

Output derating is required for AC input voltage less than 90VAC.

For more information about Output derating, please refer to “LOAD vs INPUT VOLTAGE” of specifications.

Vin	Iout : 100%
90 - 265VAC	100%
85VAC	80%

2. 特性データ Characteristics

2-1. 静特性 Steady state data

(1) 入力・負荷・温度変動／出力起動・遮断電圧

Regulation - line and load, Temperature drift / Start up voltage and Drop out voltage

24V

1. Regulation - line and load Condition Ta : 25 °C

Iout \ Vin	90VAC	100VAC	200VAC	265VAC	line regulation	
0%	24.007V	24.006V	24.006V	24.006V	1mV	0.006%
50%	23.979V	23.979V	23.979V	23.979V	0mV	0.000%
100%	23.951V	23.951V	23.951V	23.951V	0mV	0.000%
load regulation	56mV	55mV	55mV	55mV		
	0.311%	0.306%	0.306%	0.306%		

2. Temperature drift

Conditions Vin : 100 VAC
Iout : 100 %

Ta	-10°C	+25°C	+50°C	temperature stability	
Vout	23.918V	23.951V	23.935V	33mV	0.183%

3. Start up voltage and Drop out voltage

Conditions Ta : 25 °C
Iout : 100 %

Start up voltage (Vin)	77VAC
Drop out voltage (Vin)	50VAC

(2) リップルノイズ電圧対入力電圧 Ripple noise voltage vs. Input voltage

Conditions Iout: 100%

Ta : -10°C ---
25°C - - -
50°C —

24V

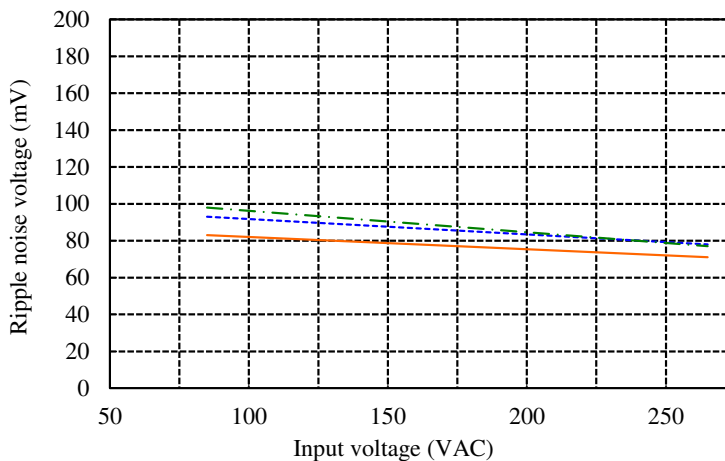

(3) 効率・力率対出力電流 Efficiency and Power factor vs. Output current

Conditions Vin : 90VAC ---
 100VAC ---
 200VAC ---
 265VAC ---
 Ta : 25°C

24V

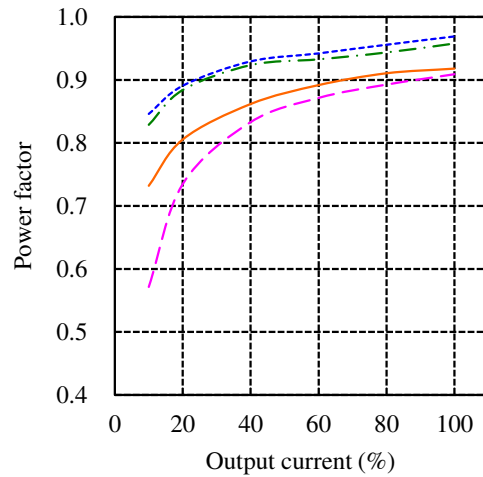
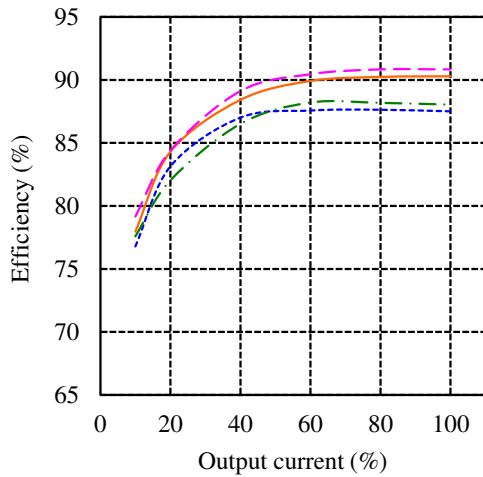

(4) 入力電力対出力電流 Input power vs. Output current

Conditions Vin : 90VAC ---
 100VAC ---
 200VAC ---
 265VAC ---
 Ta : 25°C

24V

Vin	Input power	
	Iout : 0%	Control OFF*
90VAC	2.0W	1.7W
100VAC	2.2W	2.0W
200VAC	2.4W	2.1W
265VAC	2.0W	1.8W

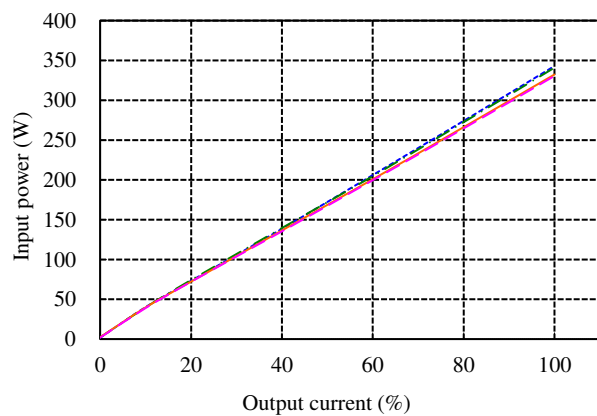

標準品 ZWS300RC-/R にて対応
 For option model ZWS300RC-*/R

(5) 入力電流対出力電流 Input current vs. Output current

Conditions Vin : 90VAC ---
 100VAC - - -
 200VAC ———
 265VAC - · - ·
 Ta : 25°C

24V

Vin	Input current	
	Iout : 0%	Control OFF*
90VAC	0.07A	0.06A
100VAC	0.07A	0.06A
200VAC	0.08A	0.07A
265VAC	0.11A	0.10A

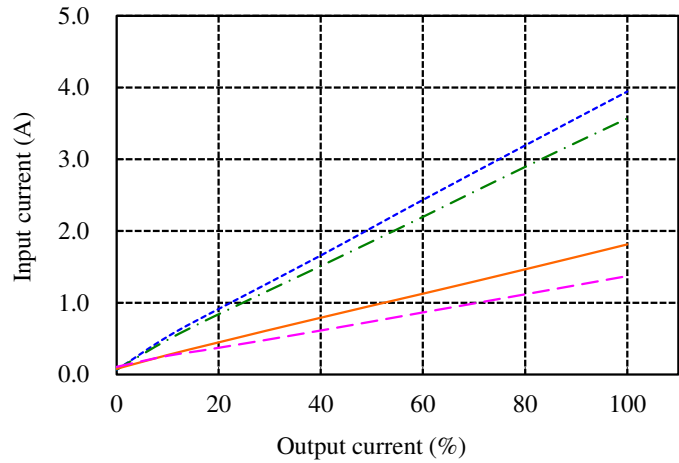

標準品 ZWS300RC-/R にて対応
 For option model ZWS300RC-*/R

2-2. 通電ドリフト特性 Warm up voltage drift characteristics

Conditions Vin : 100VAC
Iout : 100%
Ta : 25°C

24V

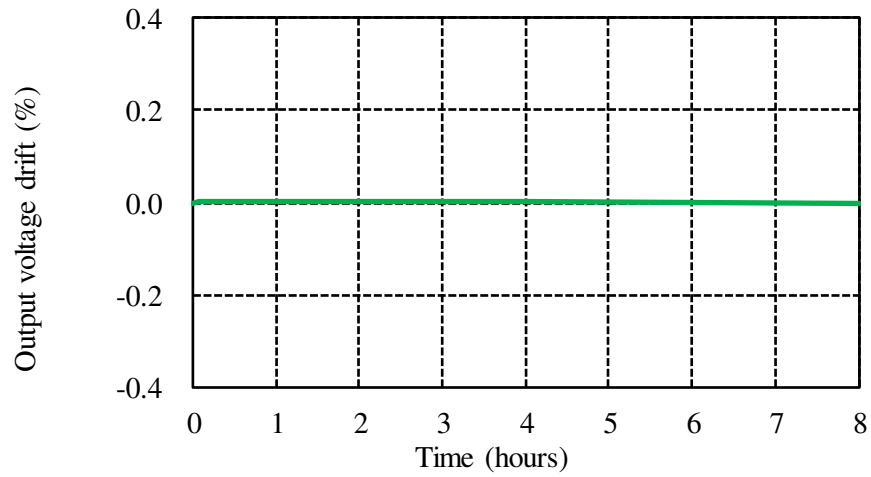

2-3. 出力保持時間特性 Hold up time characteristics

Conditions Vin : 100VAC ———
200VAC - - - - -
Ta : 25°C

24V

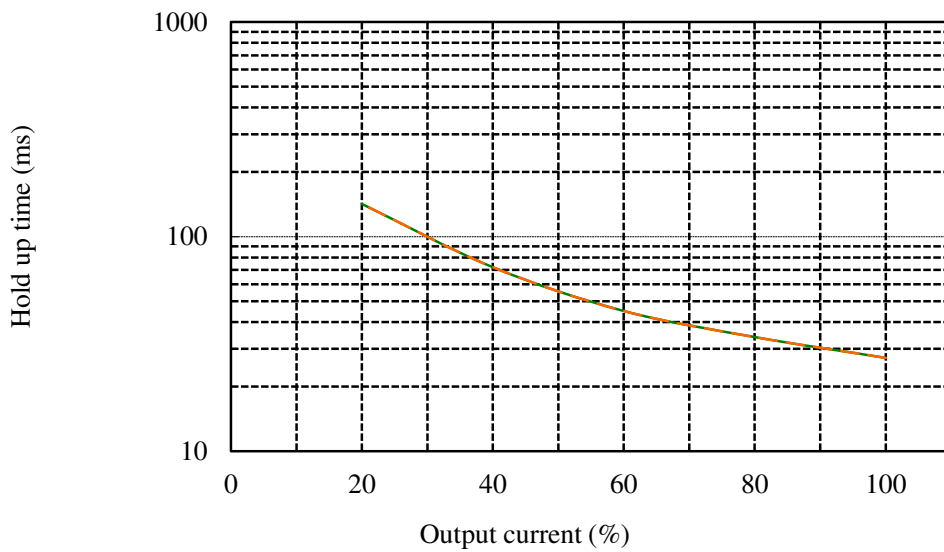

2-4. 出力立ち上がり特性 Output rise characteristics

Conditions Vin : 90VAC (A)
 : 100VAC (B)
 : 200VAC (C)
 : 265VAC (D)
 Ta : 25°C

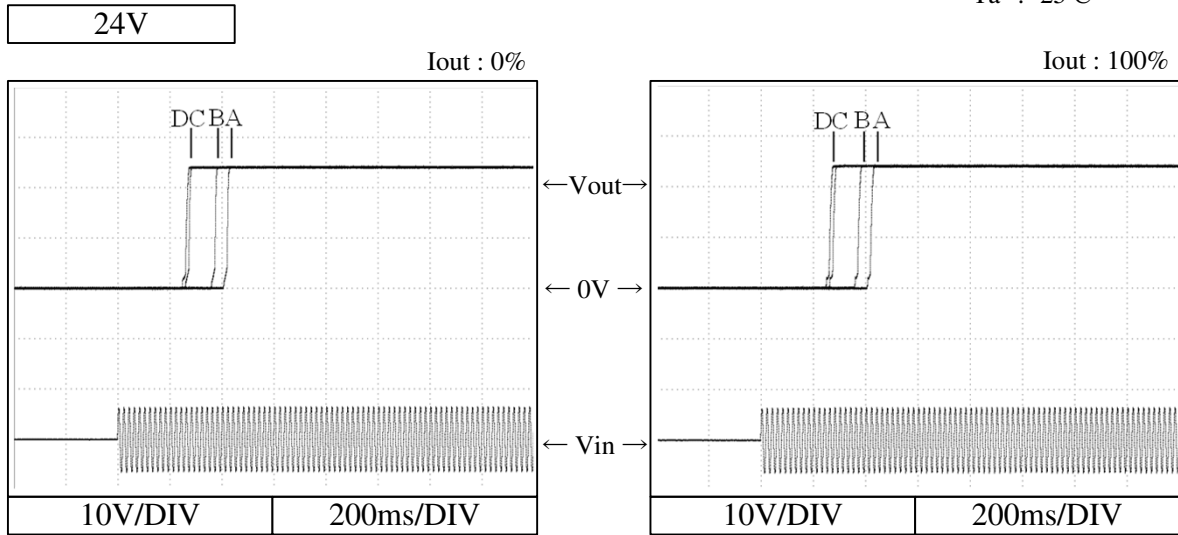

2-5. 出力立ち下がり特性 Output fall characteristics

Conditions Vin : 90VAC (A)
 : 100VAC (B)
 : 200VAC (C)
 : 265VAC (D)
 Ta : 25°C

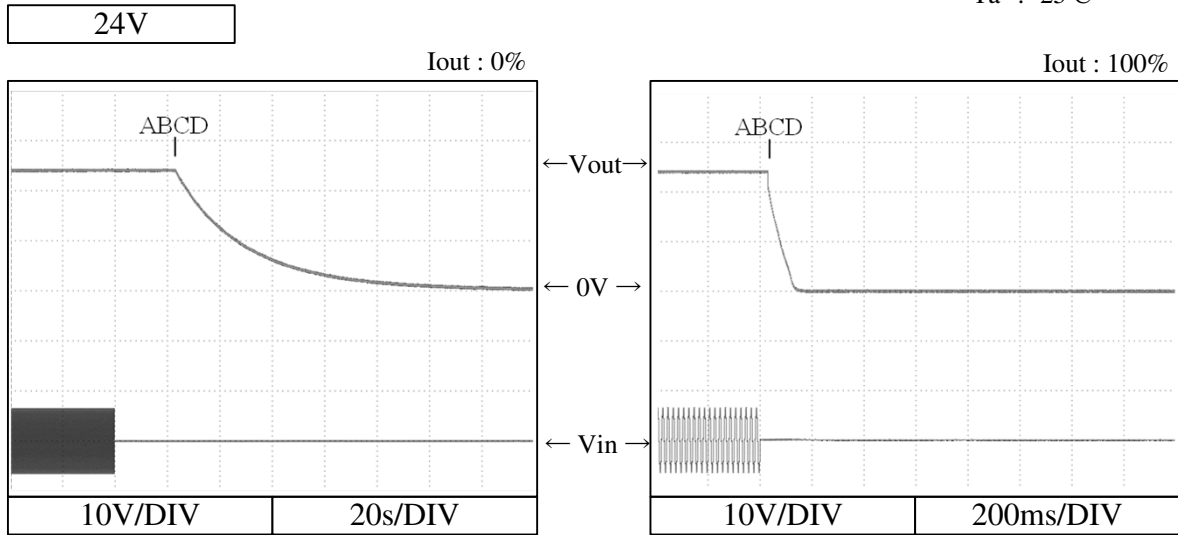

2-6. ON/OFFコントロール時出力立ち上がり、立ち下がり特性 Output rise, fall characteristics with ON/OFF Control

標準品 ZWS300RC-*/R にて対応
For option model ZWS300RC-*/R

Conditions V_{in} : 100VAC
 I_{out} : 100%
 T_a : 25°C

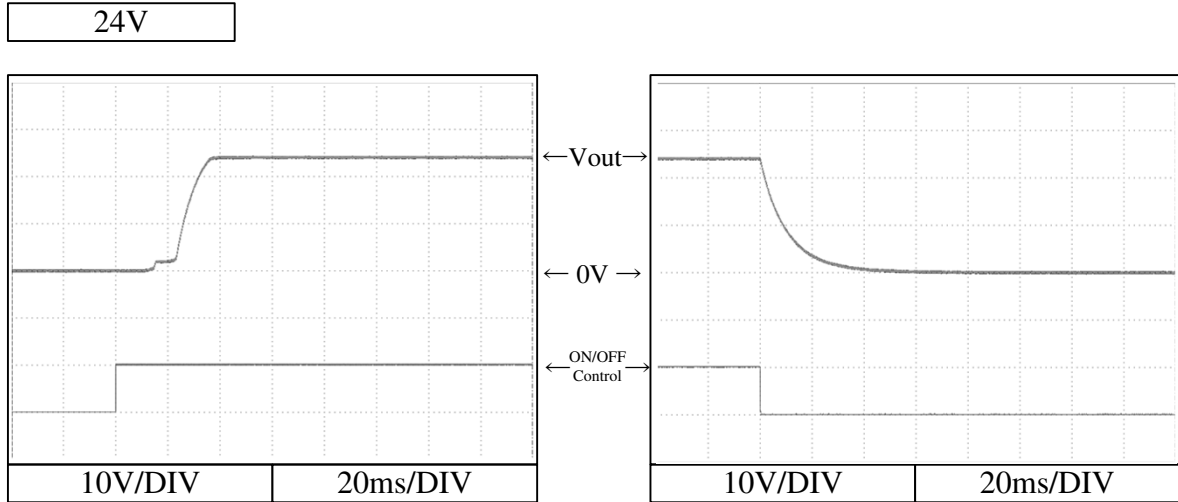

2-7. 過電流保護特性

Over current protection (OCP) characteristics

Conditions Vin : 100VAC
 Ta : -10°C -----
 25°C -.-.-.-
 50°C ————

24V

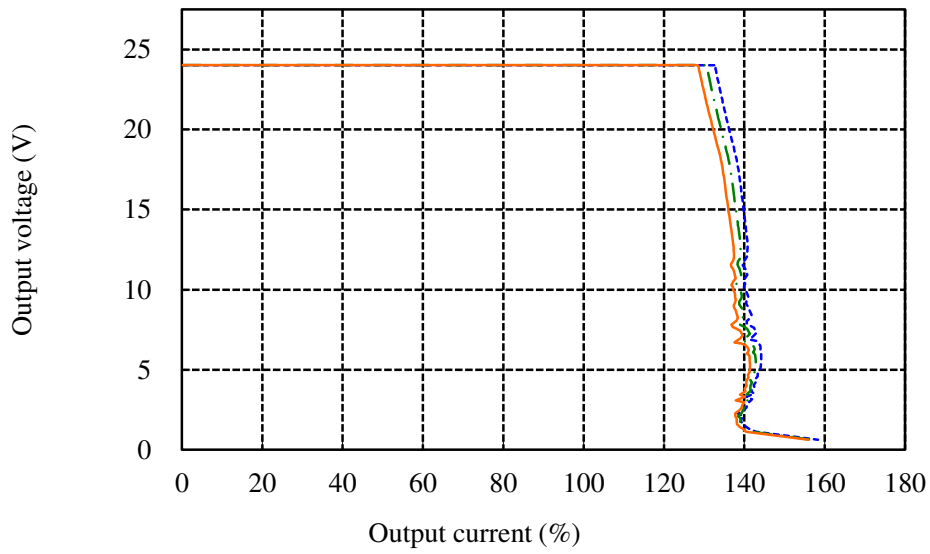

2-8. 過電壓保護特性

Over voltage protection (OVP) characteristics

Conditions Vin : 100VAC
 Iout : 0%
 Ta : 25°C

24V

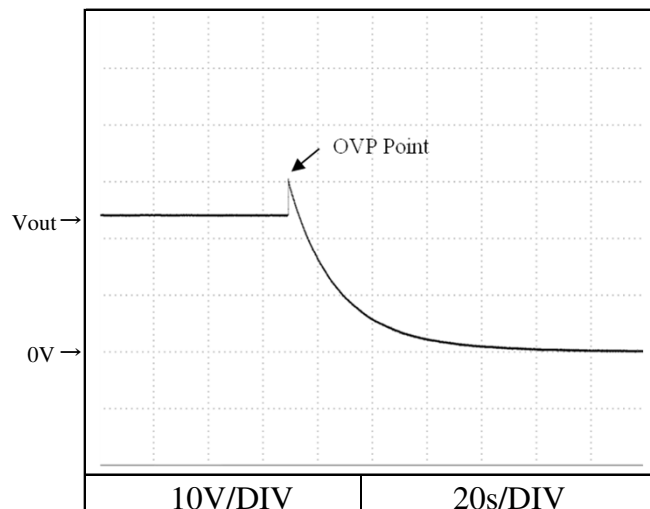

2-9. 過渡応答(入力急変)特性 Dynamic line response characteristics

Conditions Vin : 90VAC \longleftrightarrow 132VAC (A)
 170VAC \longleftrightarrow 265VAC (B)
 Iout : 100%
 Ta : 25°C

24V

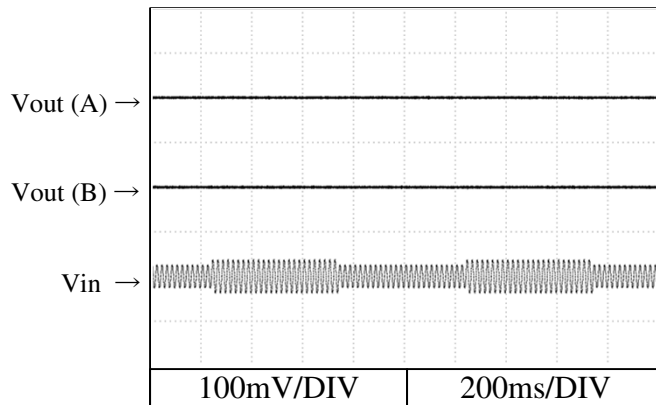

2-10. 過渡応答(負荷急変)特性 Dynamic load response characteristics

Conditions Vin : 100VAC
 Iout : 50% \longleftrightarrow 100%
 (tr = tf = 50us)
 Ta : 25°C

24V

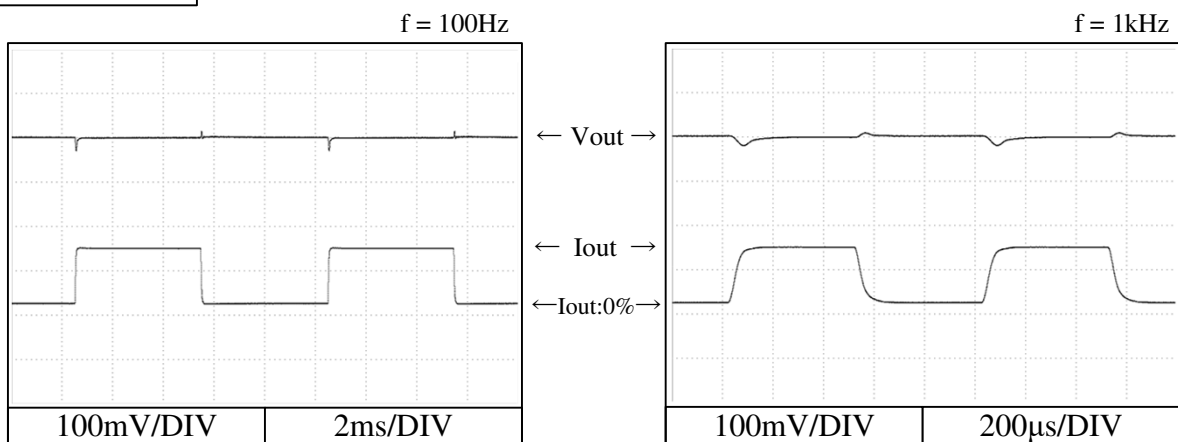

2-11. 入力電圧瞬停特性 Response to brown out characteristics

Conditions Iout : 100%

Ta : 25°C

瞬停時間 Interruption time

A : 出力電圧が低下なし Output voltage does not drop.

B : 出力電圧が0Vまで低下しない Output voltage drop down not reaching 0V.

C : 出力電圧が0Vまで低下 Output voltage drops until 0V.

24V

Vin : 100VAC

A = 26ms, B = 30ms, C = 118ms

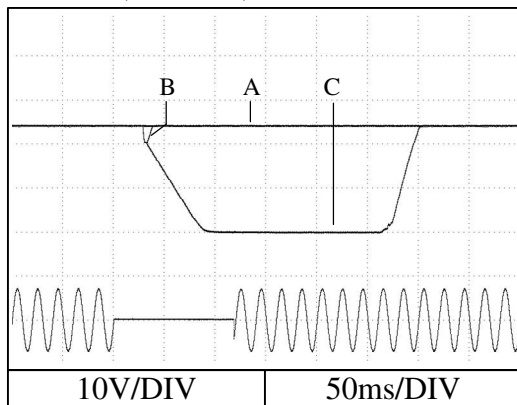

Vin : 200VAC

A = 27ms, B = 30ms, C = 118ms

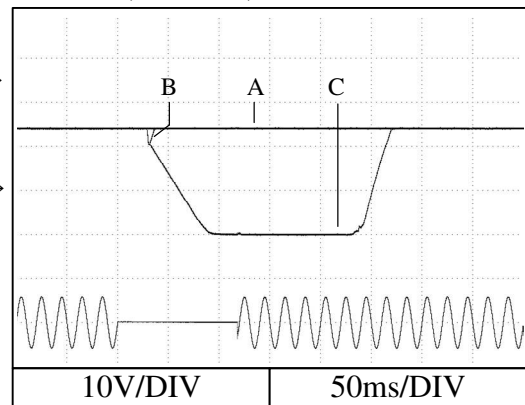

2-12. 入力サージ電流(突入電流)波形 Inrush current waveform

24V

Conditions Vin : 100VAC
Iout : 100%
Ta : 25°C

Switch on phase angle of input AC voltage
 $\phi = 0^\circ$

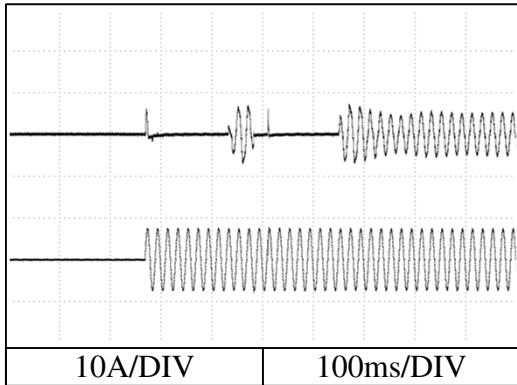

Switch on phase angle of input AC voltage
 $\phi = 90^\circ$

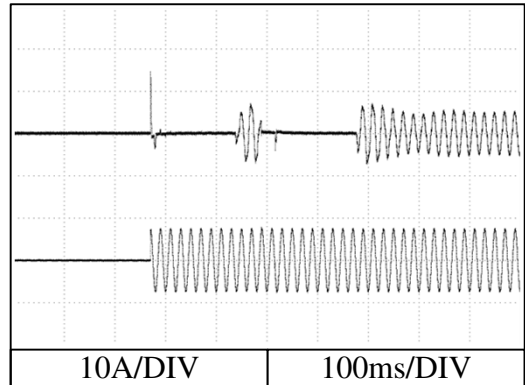

Switch on phase angle of input AC voltage
 $\phi = 0^\circ$

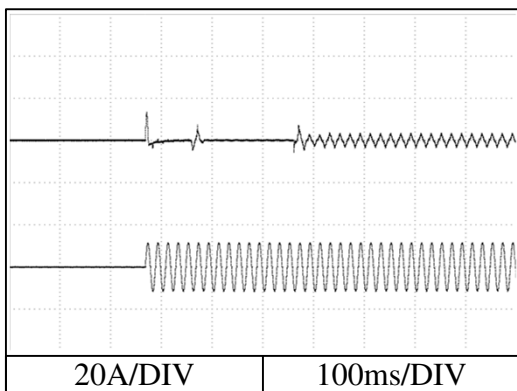

Switch on phase angle of input AC voltage
 $\phi = 90^\circ$

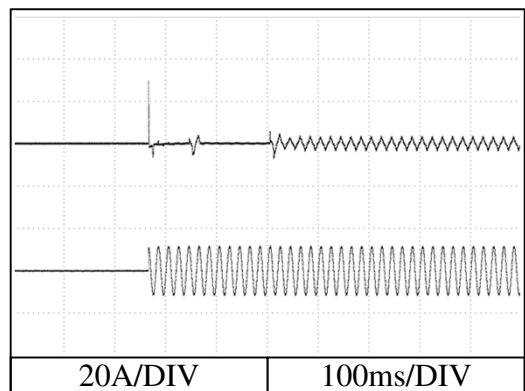

Conditions Vin : 200VAC
Iout : 100%
Ta : 25°C

2-13. 高調波成分 Input current harmonics

Conditions Iout : 100%

Ta : 25°C

24V

Vin : 100VAC

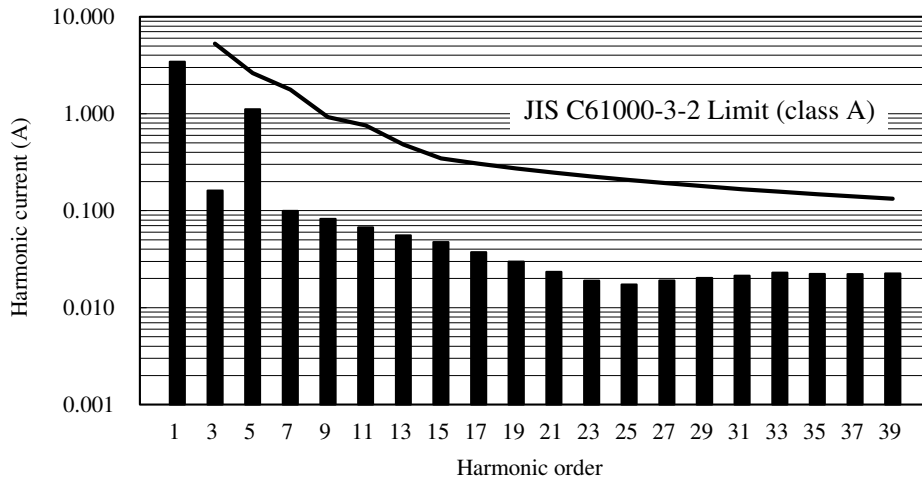

Vin : 230VAC

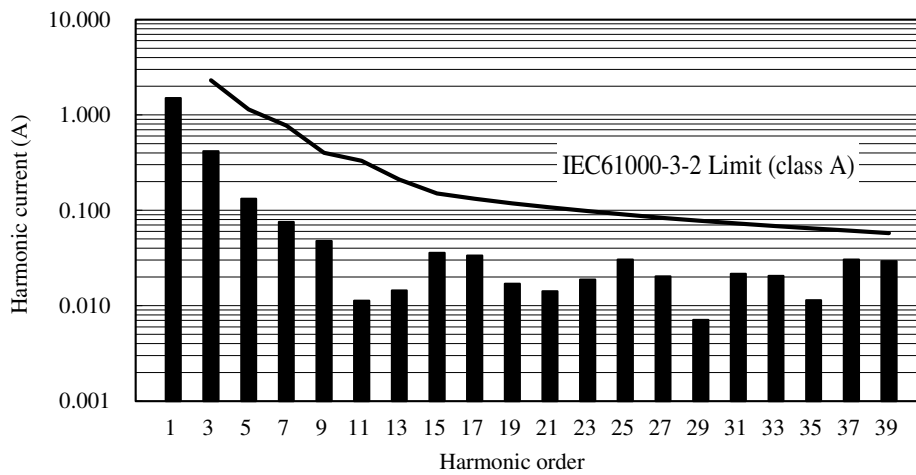

2-14. 入力電流波形 Input current waveform

Conditions Iout : 100%

Ta : 25°C

24V

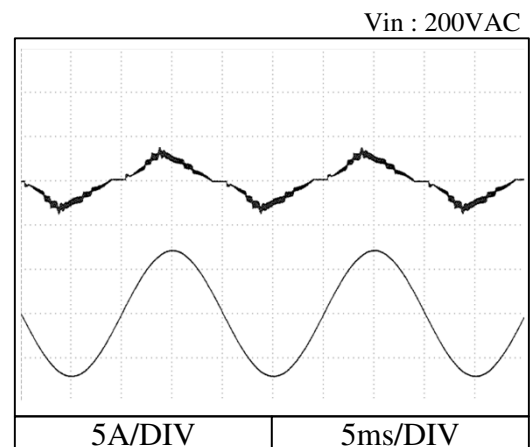
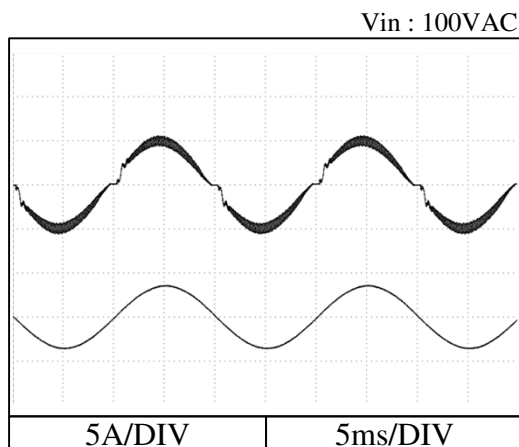

2-15. リーク電流特性 Leakage current characteristics

Conditions Iout : 0% ———
 100% - - - - -
 Ta : 25°C
 Equipment used : 3156 (HIOKI)

24V

f : 50Hz

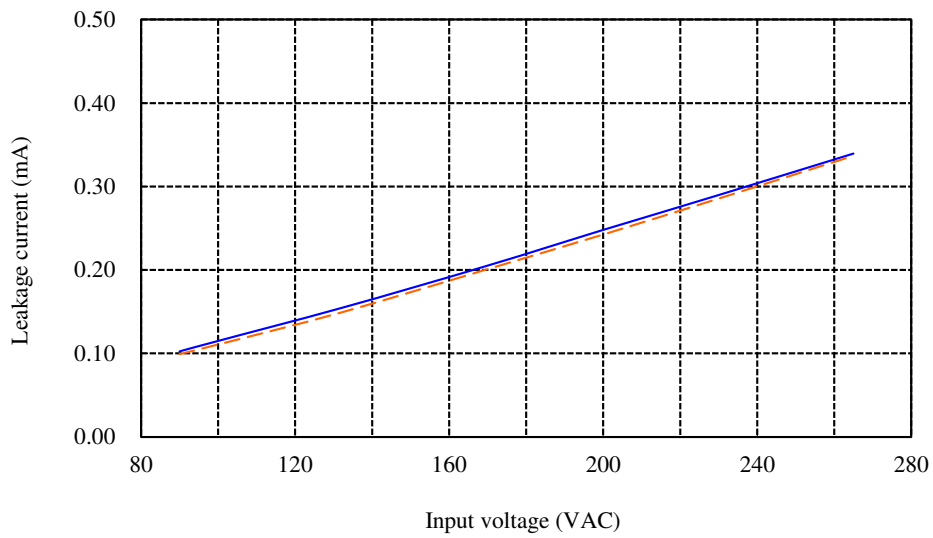

f : 60Hz

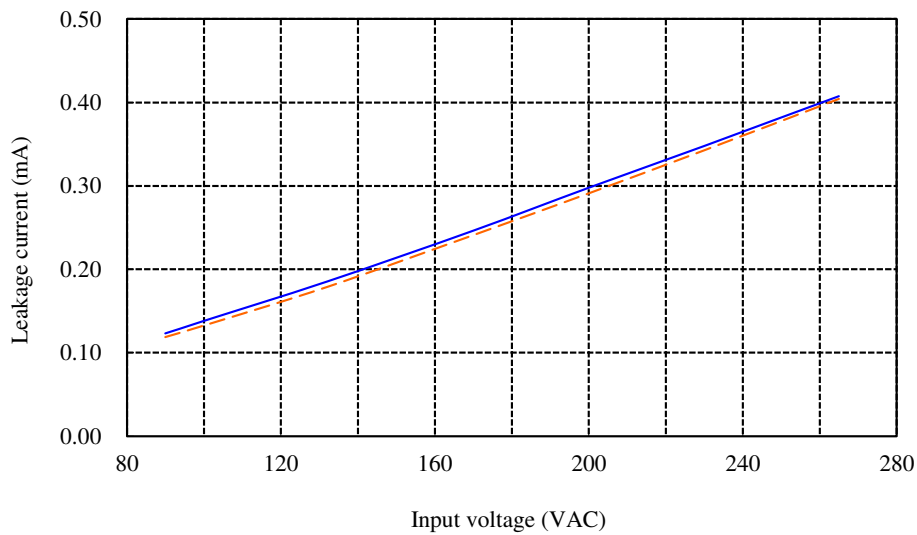

2-16. 出力リップル、ノイズ波形 Output ripple and noise waveform

Conditions Vin : 100VAC
Iout : 100%
Ta : 25°C

24V

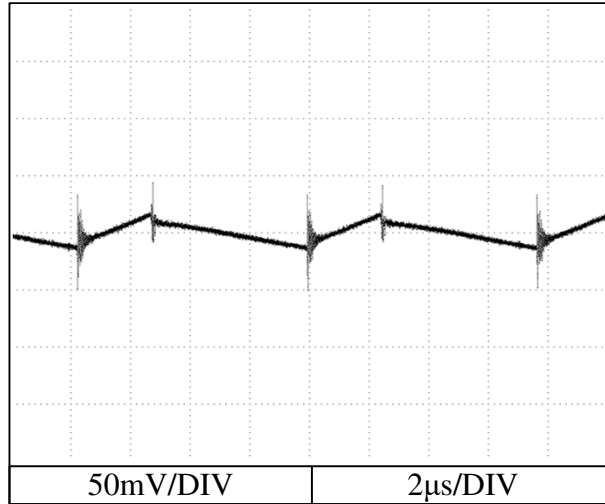

2-17. EMI特性 Electro-Magnetic Interference characteristics

Conditions Vin : 230VAC
Iout : 100%
Ta : 25°C

雑音端子電圧 Conducted Emission

24V

Point A (202kHz)		
Ref. Data	Limit (dB)	Measure (dB)
QP	63.5	45.7
AV	53.5	42.5

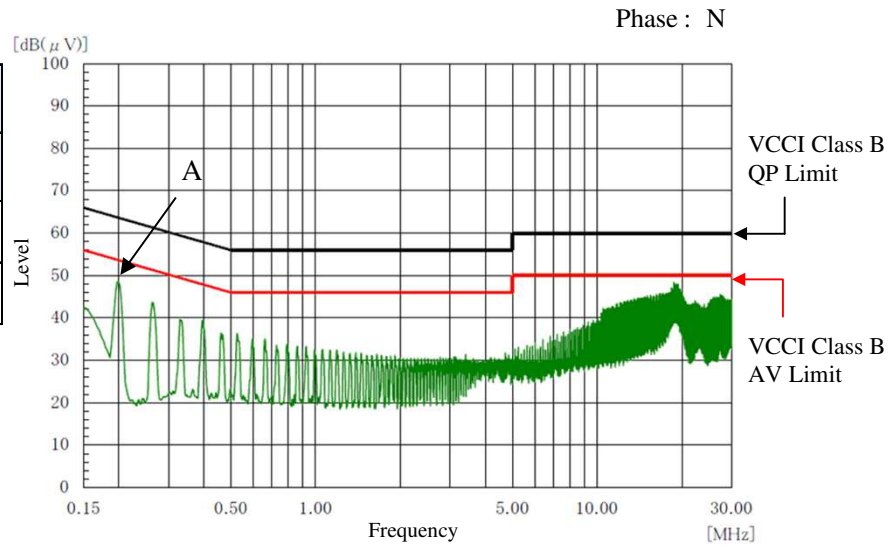

Point B (199kHz)		
Ref. Data	Limit (dB)	Measure (dB)
QP	63.7	47.3
AV	53.7	53.6

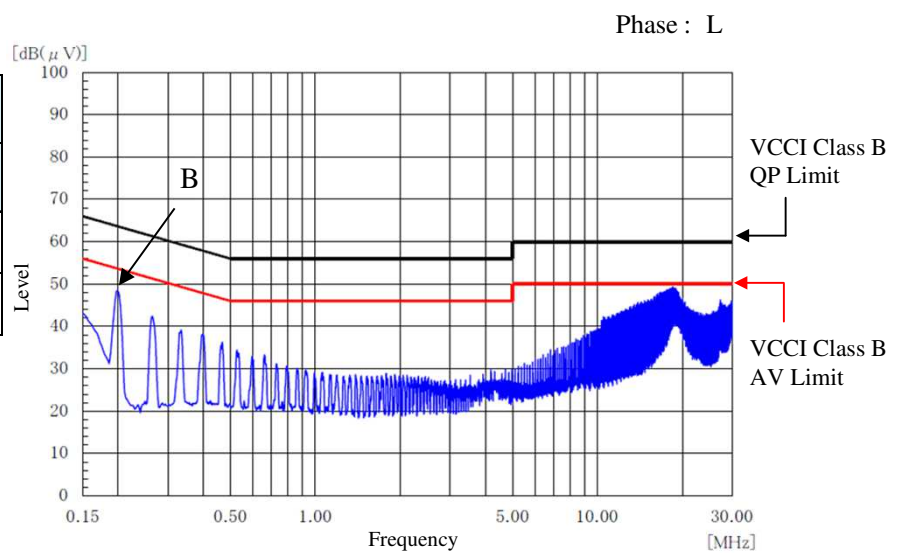

EN55011-B,EN55032-B,FCC-Bの限界値はVCCI class Bの限界値と同じ
Limit of EN55011-B,EN55032-B,FCC-B are same as its VCCI class B.

表示はピーク値

Indication is peak values.

2-17. EMI特性 Electro-Magnetic Interference characteristics

Conditions Vin : 230VAC
 Iout : 100%
 Ta : 25°C

雑音電界強度 Radiated Emission

24V

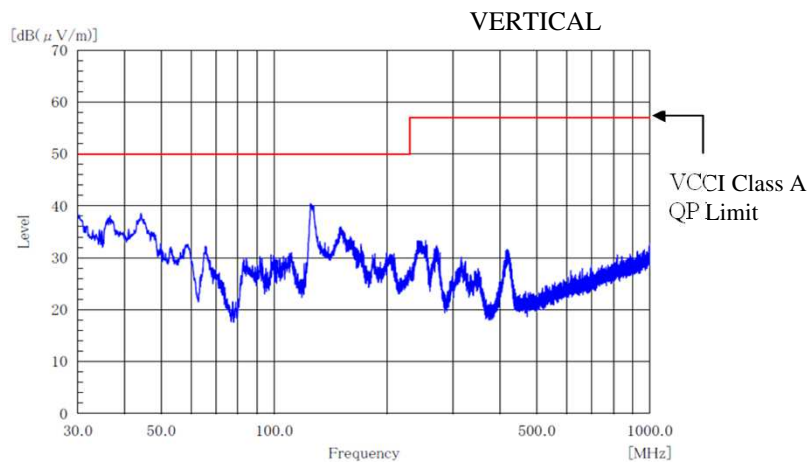
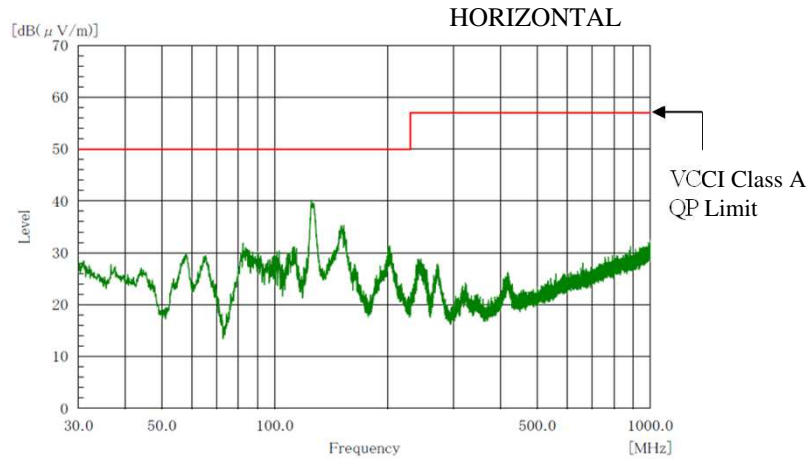

EN55011-A,EN55032-Aの限界値はVCCI class Aの限界値と同じ
 Limit of EN55011-A,EN55032-A are same as its VCCI class A.

表示はピーク値
 Indication is peak values.