

HMS 50-150 Series

Instruction Manual

BEFORE USING THE POWER SUPPLY UNIT

Be sure to read this instruction manual thoroughly before using this product. Pay attention to all cautions and warnings before using this product. Incorrect usage could lead to an electrical shock, damage to the unit or a fire hazard.

DANGER

Never use this product in locations where flammable gas or ignitable substances are present.

INSTALLATION WARNING

- When installing, ensure that work is done in accordance with the instruction manual. When installation is improper, there is risk of electric shock and fire.
- Installation shall be done by Service personnel with necessary and appropriate technical training and experience. There is a risk of electric shock and fire.
- Do not cover the product with cloth or paper etc. Do not place anything flammable around. This might cause damage, electric shock or fire.

WARNING ON USE

- Do not touch this product or its internal components while circuit in operation, or shortly after shutdown. You may receive a burn.
- While this product is operating, keep your hands and face away from it as you may be injured by an unexpected situation.
- For products with no cover, do not touch them as there are high-voltage and high temperature parts inside. Touching them might cause injury such as electric shock or burn.
- There are cases where high voltage charge remains inside the product. Therefore, do not touch even if they are not in operation as you might get injured due to high voltage and high temperature. You might also get electric shock or burn.
- Do not make unauthorized changes to this product nor remove the cover as you might get an electric shock or might damage the product. We will not be held responsible after the product has been modified, changed or dis-assembled.
- Do not use this product under unusual condition such as emission of smoke or abnormal smell and sound etc. Please stop using it immediately and shut off the product.
It might lead to fire and electric shock. In such cases, please contact us. Do not attempt repair by yourself, as it is dangerous for the user.
- Do not operate and store these products in environments where condensation occurs due to moisture and humidity. It might lead fire and electric shock.
- Do not drop or apply shock to this product. It might cause failure. Do not operate these products mechanical stress is applied.

CAUTION ON MOUNTING

- Confirm connections to input/output terminals are correct as indicated in the instruction manual before switching on.
- Input voltage, Output current, Output power, ambient temperature and ambient humidity should be kept within specifications, otherwise the product will be damaged.
- Input line, please use the wires as short and thick as possible.
- Do not use this product in special environment with strong electromagnetic field, corrosive gas or conductive substances and direct sunlight, or places where product is exposed to water or rain.
- Mount this product properly in accordance with the instruction manual, mounting direction and shall be properly be ventilated.
- Please shut down the input when connecting input and output of the product.
- When installing in environment where conductive foreign, dust and liquid may be present, please consider penetration of above foreign material in the power supply by installing filter, to prevent trouble or malfunction.

⚠ CAUTION ON USE

- Product individual notes are shown in the instruction manual. If there is any difference with common notes individual notes shall have priority.
- Before using this product, be sure to read the catalog and instruction manual. There is risk of electric shock or damage to the product or fire due to improper use.
- Input voltage, Output current, Output power, ambient temperature and ambient humidity should be kept within specifications, otherwise the product will be damaged, or cause electric shock or fire.
- If the built-in fuse is blown, do not use the product even after replacing the fuse, as there is risk of abnormality inside. Be sure to request repair to our company.
- For products without built-in protection circuit (element, fuse, etc.), insert fuse at the input to prevent smoke, fire during abnormal operation.
As for products with built-in protection circuit, depending on usage conditions, built-in protection circuit might not work. It is recommended to provide separate proper protection circuit.
- For externally mounted fuse do not use other fuses aside from our specified and recommended fuse.
- This product was made for general purpose electronic equipment use and is not designed for applications requiring high safety (such as extremely high reliability and safety requirements. Even though high reliability and safety are not required, this product should not be used directly for applications that have serious risk for life and physical safety. Take sufficient consideration in fail-safe design (such as providing protective circuit or protective device inside the system, providing redundant circuit to ensure no instability when single device failure occurs).
- When used in environments with strong electromagnetic field, there is possibility of product damage due to malfunction.
- When used in environment with corrosive gas (hydrogen sulfide, sulfur dioxide, etc.) , there is possibility that they might penetrate the product and lead to failure.
- When used in environments where there is conductive foreign matter or dust, there is possibility of product failure or malfunction.
- Provide countermeasure for prevention of lightning surge voltage as there is risk of damage due to abnormal voltage.
- Connect together the frame ground terminal of the product and the ground terminal of the equipment for safety and noise reduction. If these ground is not connected together, there is risk of electric shock.
- Parts with lifetime specifications (built-in fan electrolytic capacitor) are required to be replaced periodically. Set the overhaul period depending on the environment of usage and perform maintenance.
Also, note that there are cases when EOL products cannot be overhauled.
- Take care not to apply external abnormal voltage to the output. Especially, applying reverse voltage or overvoltage more than the rated voltage to the output might cause failure, electric shock or fire.
- Never operate the product under over current or short-circuit conditions, or outside its specified Input Voltage Range. Insulation failure, smoking, burning or other damage may occur.
- This product contains a printed circuit board utilizing surface mounted devices. PCB stress such as bending, twisting etc. could cause damage. Therefore, please handle with care.
- This power supply is designed and manufactured for use within an end product such that it is accessible to SERVICE ENGINEERS only.

⚠ NOTE

- Take note that traces of sheet metal processing be left in our power supplies.
- When disposing product, follow disposal laws of each municipality.
- Published EMI (CE, RE) or immunity is the result when measured in our standard measurement conditions and might not satisfy specification when mounted and wired inside end-user equipment.
Use the product after sufficiently evaluating at actual end-user equipment.
- When exporting our products, apply for necessary permissions as required by rules and regulations of Foreign Exchange and Foreign Trade Control Act.
- Catalogue, contents of the instruction manual may be changed without a prior notice. Refer to latest catalogue or instruction manual.
- Reproduction or reprinting the instruction manual or its portion is forbidden without our permission.

⚠ LONG-TERM STORAGE METHOD AND LONG-TERM STORAGE PERIOD

- Please keep the product in carton box.
- Please do not apply excessive vibration, shock or mechanical stress applied directly to the product.
- Please keep away from direct sunlight.
- For long-term storage temperature and humidity, the following conditions shall be used as a guideline :
 - Temperature range : 5°C~30°C
 - Humidity range : 40%~60%RH
 - Please keep away from the places where temperature and humidity can change drastically.
 - It can cause condensation on the product or deterioration.
- For long-term storage period, we recommend to use within 2 years after receiving the product.
 - < Unit type or PCB type of products : the product is used an aluminium electrolytic capacitor >
 - There is tendency that the leakage current of an aluminium electrolytic capacitor may increase when stored without using for a long time. This phenomenon can be improved by applying voltage to the aluminum electrolytic capacitor to reduce the increased leakage current through the self-recovery effect of the electrolyte.
 - For reference, before using products that have been stored for a very long time, please warm-up first for 30 minutes or more without taking load.
 - < Criterion of warm up voltage condition >
 - (1)Implementation period : 1 year or above after the delivery
 - (2)Electrical continuity condition
 - Input voltage : Rating
 - Load : 0A
 - Ambient temperature : Normal temperature
 - Time : 30 minutes or more

1. Model name identification method

HMS 50 - 5 / □

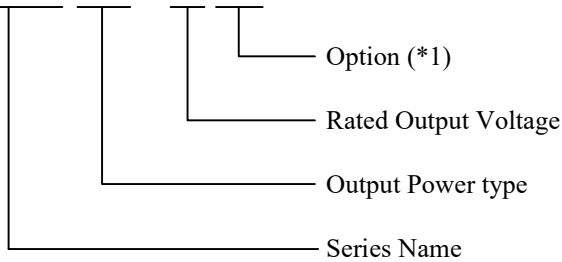

(*1) Blank : Standard model.
 /R : Remote ON/OFF control model.

2. Terminal Explanation

HMS50

- ① +V : + Output terminal
(15A max. / terminal)
- ② -V : - Output terminal
(15A max. / terminal)
- ③ FG : Frame Ground
- ④ L : Input terminal Live line (Fuse in line)
- ⑤ N : Input terminal Neutral line
- ⑥ Output voltage adjustment trimmer
- ⑦ Output monitoring indicator (Green LED)

*All screws size is M3.5

HMS50/R

- ⑧ -R : Remote ON/OFF control terminal
- ⑨ +R : Remote ON/OFF control terminal

*Remote ON/OFF control Connector (JST)

Connector	Housing	Terminal Pin
B2B-XH-AM	XHP-2	BXH-001T-P0.6 or SXH-001T-P0.6

Hand Crimping Tool : YC-110R (JST) or YRS-110 (JST)

Use maker recommended crimping tool.

Matching housing and terminal pin are not included in the product.

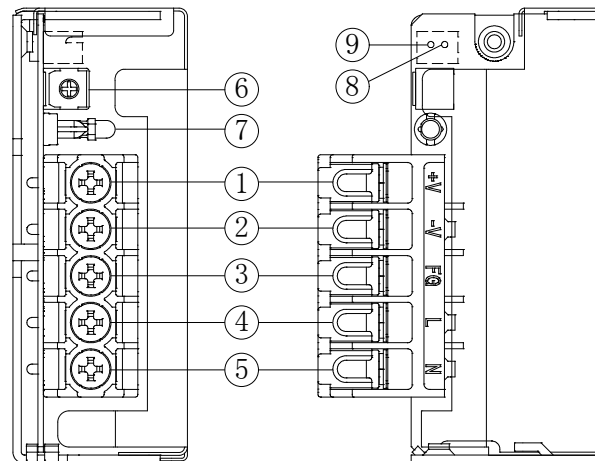

HMS80, HMS100, HMS150

- ① +V : +Output terminal
(30A max. / terminal)
- ② -V : -Output terminal
(30A max. / terminal)
- ③ FG : Frame Ground
- ④ L : Input terminal Live line (Fuse in line)
- ⑤ N : Input terminal Neutral line
- ⑥ +S : +Remote sensing terminal
- ⑦ -S : -Remote sensing terminal
- ⑧ Output voltage adjustment trimmer
- ⑨ Output monitoring indicator (Green LED)

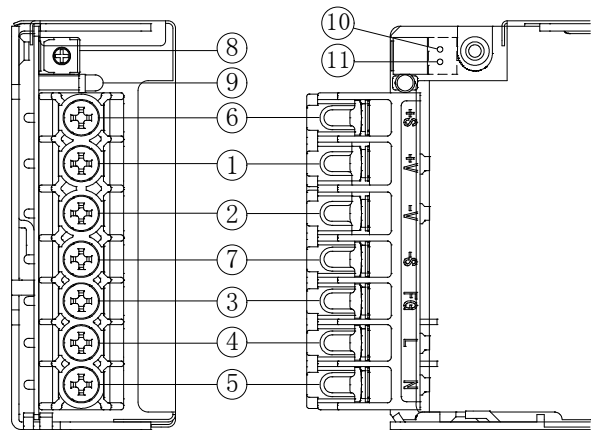

*All screws size is M3.5

HMS80/R, HMS100/R, HMS150/R

- ⑩ -R : Remote ON/OFF control terminal
- ⑪ +R : Remote ON/OFF control terminal

*Remote ON/OFF control Connector (JST)

Connector	Housing	Terminal Pin
B2B-XH-AM	XHP-2	BXH-001T-P0.6 or SXH-001T-P0.6

Hand Crimping Tool : YC-110R (JST) or YRS-110 (JST)

Use maker recommended crimping tool.

Matching housing and terminal pin are not included in the product.

3. Block Diagram

HMS50

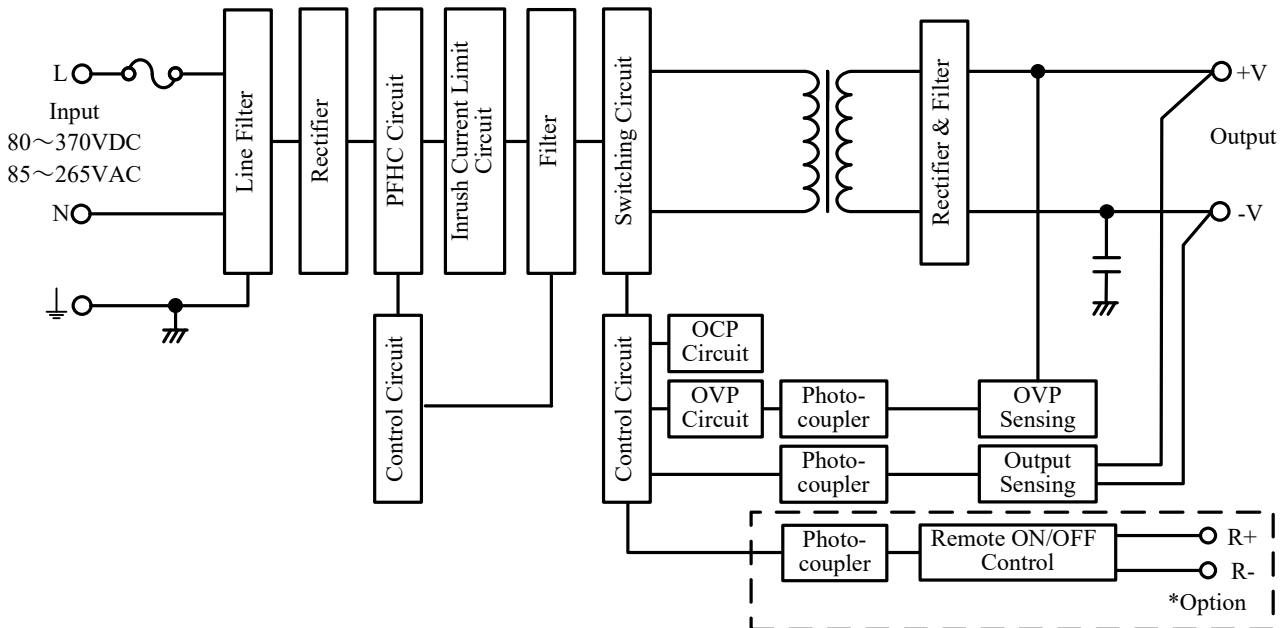

HMS80, HMS100, HMS150

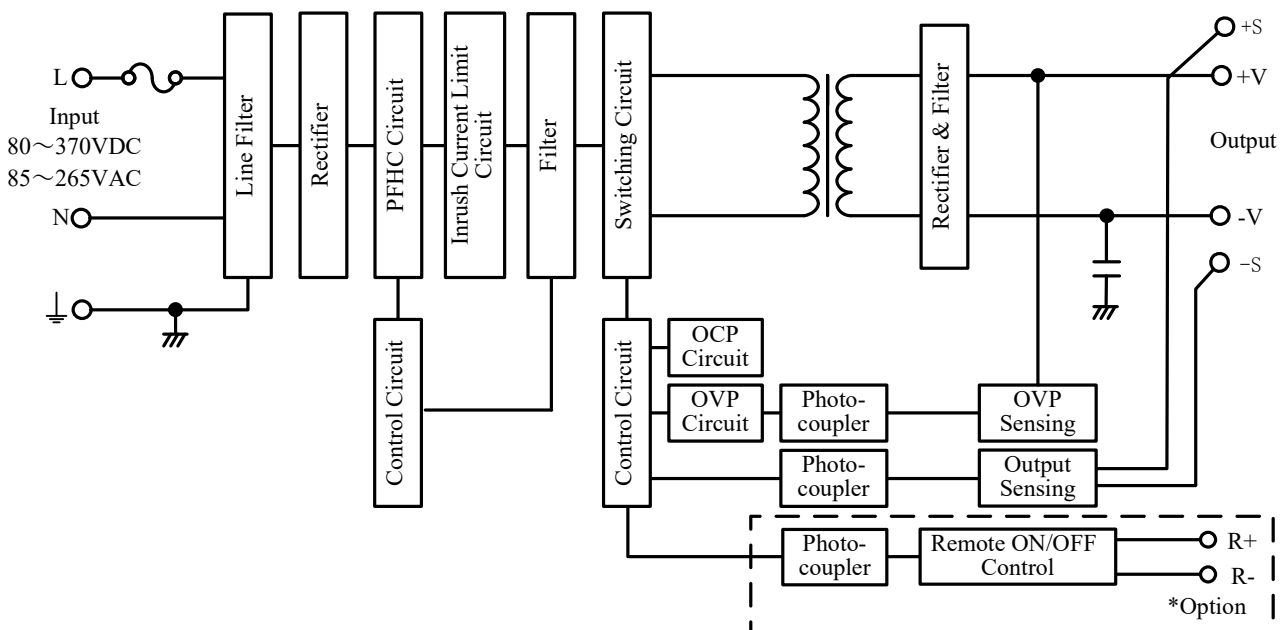

Fuse rating :

HMS50-100 : 3.15A

HMS150 : 5A

Circuit topology, switching frequency

HMS50 : Flyback topology 100kHz

HMS80-150 : Cascade forward topology 120kHz

PFHC circuit : active filter 65kHz (fixed)

4. Sequence Time Chart

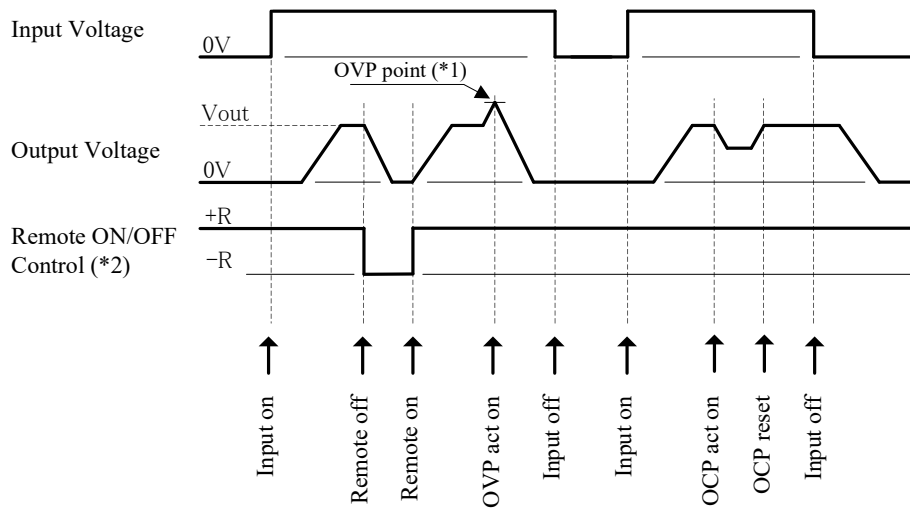

(*1) OVP Point

5V : 133%~155%

12V - 24V : 125%~145%

48V : 115%~135%

(*2) +R & -R level

4.5V or higher : ON

0.8V or less : OFF

5. Connecting method

Pay attention to the input wiring. If it is connected to wrong terminal, the power supply will be damaged.

- Input must be off when making connections.
- Connect FG terminal to earth (frame ground of the equipment etc.) by thick wire for safety and improvement of noise sensitivity.

HMS50

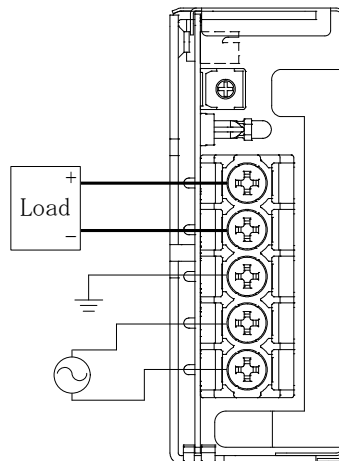

HMS80, HMS100, HMS150

•Basic connection (Local sensing)

Connect “+S” terminal to “+V” terminal, and “-S” terminal to “-V” terminal with the attached short pieces.

(Short pieces are mounted at time of shipment.)

•Remote sensing connection

Connect “+S” terminal to “+” terminal of load, and “-S” terminal to “-” terminal of load with wires.

If remote sensing terminals are opened, the output will rise and OVP may be triggered.

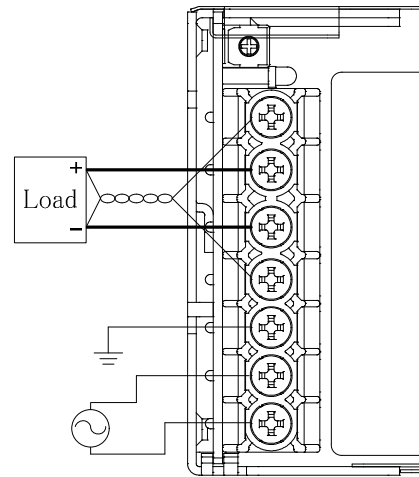
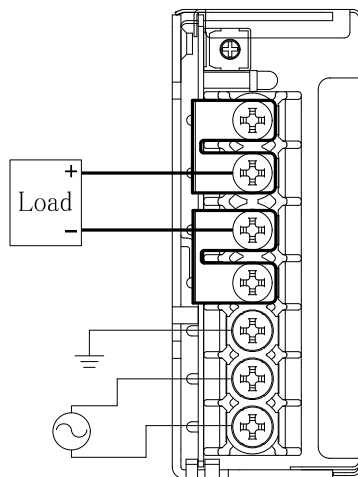

Recommended torque : HMS50~HMS150 M3.5 screw 1.0N·m (10.2kgf·cm) ~ 1.6N·m (16.3kgf·cm)

6. Explanation of Functions and Precautions

6-1. Input Voltage Range

Input voltage range is single phase 85-265VAC (47-63Hz) or 80-370VDC. Input voltage, which is out of specification, might lead unit damage. The slope of the rising / falling edge of the input voltage should be less than 15V / μ s.

HMS50, HMS80, HMS100 : Output derating is required for DC input voltage less than 110VDC.

HMS150 : Output derating is required for DC input voltage less than 95VDC.

Regarding the output derating, Please see at “7-2. Output Derating according to the Mounting Directions”.

Note : HMS series is possible to apply the input voltage for 20 seconds at a load factor of 60% , when input voltage range is "75VAC \leq Vin<85VAC". Please note that to satisfy the electrical characteristics, the input voltage range must be within 85-265VAC.

6-2. Output Voltage Range

Output voltage is set the rated value at shipment. V.ADJ trimmer can adjust the output voltage within the range. Output voltage range is within +/- 20% (5V : +28%/-20%, 12V : +20%/-25%, 48V : +10%/-20%) of nominal output voltage. To turn the trimmer clockwise, the output voltage will be increased. Take note when the output voltage is increased excessively, over voltage protection (OVP) function may trigger and voltage will be shut down. Furthermore, when increasing the output voltage reduce the output current so as not to exceed the maximum output power.

6-3. Inrush Current

This series equipped Power thermistor to limit the inrush current. This series are Power thermistor method so that higher current will flow at higher ambient temperature or re-input condition. Please select input switch and fuse carefully with the high temperature and re-input the power condition. The inrush current value is under cold start at 25°C in the specification.

6-4. Over Voltage Protection (OVP)

The OVP function is inverter shut down method and manual reset type. OVP function operates within 125-145% (5V : 133-155%, 48V : 115-135%) of nominal output voltage.

When OVP triggers, the output will be shut down. To reset OVP, remove the input voltage of power supply for a few minutes, and then re-input. In addition, the setting value of OVP is fixed and not adjustable. Pay attention not to apply higher voltage externally to the output terminal to avoid unit failure. In case of inductive load, put protective diode in series to the output power line.

6-5. Over Current Protection (OCP)

HMS50 : Fold back limit and hiccup mode with automatic recovery.

HMS80, HMS100, HMS150 :

5V : Constant current limit and hiccup with automatic recovery.

12V-48V : Constant current limit with automatic recovery.

OCP function operates when the output current exceeds 105% of maximum DC output current of specification.

The outputs will be automatically recovered when the overload condition is removed. Never operate the unit under over current or shorted conditions, which may lead unit damage. OCP setting is fixed and cannot be adjusted externally.

6-6. Remote Sensing (+S, -S terminal)

(For HMS80, HMS100, HMS150)

This function compensates voltage drop of wiring from output terminals to load terminals. Connect “+S” terminal to “+” terminal of load and “-S” terminal to “-” terminal of load with sensing wires.

The total line voltage drop (+ side line and - side line) shall be less than 0.3V.

In case that sensing line is too long, it is necessary to put an electrolytic capacitor in following 3 placed;

- 1) Across the load terminal,
- 2) Between “+S” terminal and “+V” terminal,
- 3) Between “-S” terminal and “-V” terminal.

If remote sensing terminal is opened, the output will rise and OVP may be triggered.

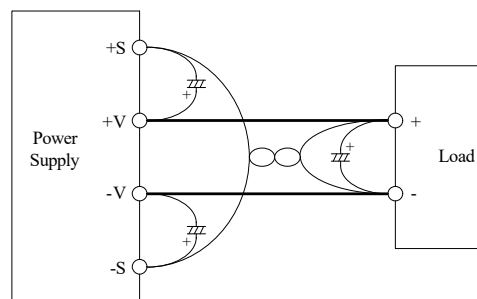

6-7. Output Ripple & Noise

The standard specification for maximum ripple value is measured according to measurement circuit specified by JEITA RC-9131B. When load lines are longer, ripple will become larger. In this case, electrolytic capacitor, film capacitor, etc. might be necessary to use across the load terminal.

The output ripple cannot be measured accurately if the probe ground lead of oscilloscope is too long.

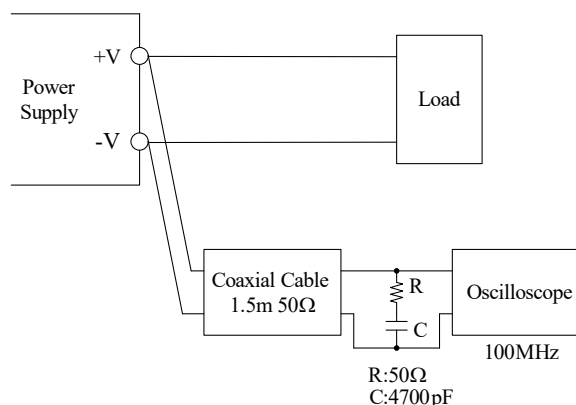

6-8. Series Operation

For series operation, either method (A) or (B) is possible.

Method (A)

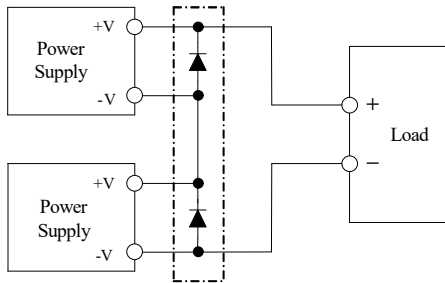

Method (B)

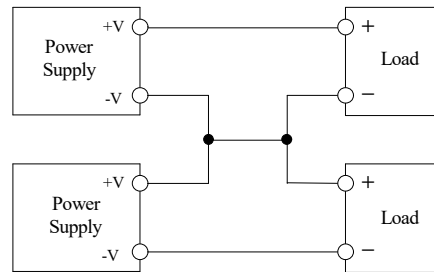

Note : In case of (A), please connect bypass diodes to prevent reverse voltage.

Please select a bypass diode with maximum forward current rating more than output load current.

And maximum reverse voltage must withstand each power supply output voltage.

*Series operation for HMS80, HMS100, HMS150 possible without bypass diode.

Never use when one of the unit not operate, which may leads damage.

6-9. Parallel Operation

(A) Operation to increase the Output Current is not possible.

(B) Operation as a Backup Power Supply is possible as follows.

1. Set the power supply output voltage higher by the amount of forward voltage drop (VF) of the diode.
2. Please adjust the output voltage of each power supply to be the same.
3. Please use within the specifications for output voltage and output power.
4. Please select a reverse current prevention diode with maximum forward current rating more than output load current.

(A)

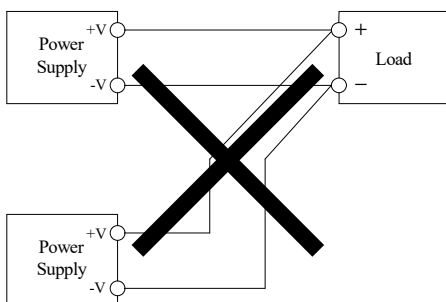

(B)

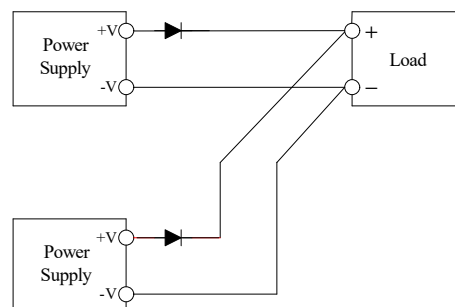

6-10. Isolation Test

Isolation resistance between Output - FG terminal is more than 100MΩ at 500VDC. For safety operation, voltage setting of DC isolation tester must be done before the test. Ensure that the unit is fully discharged after the test.

- Output - FG terminal : 500VDC More than 100MΩ

(A) HMS50

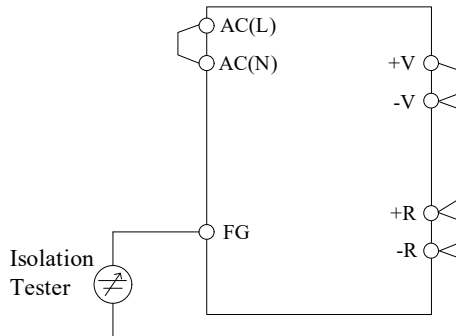

(B) HMS80, HMS100, HMS150

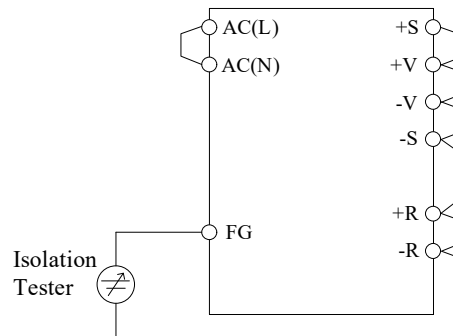

6-11. Withstand Voltage

This series is designed to withstand 3.0kVAC between input and output, 2.0kVAC between input and FG and 500VAC between output and FG each for 1 minute. When testing withstand voltage, set current limit of withstand voltage test equipment at 20mA. The applied voltage must be gradually increased from zero to testing value and then gradually decreased for shut down. When timer is used, the power supply may be damaged by high impulse voltage at timer switch on and off. Connect input and output as follows.

- Input - FG (solid line) : 2.0kVAC, 1min (20mA)
- Input - Output (dotted line) : 3.0kVAC, 1min (20mA)

(A) HMS50

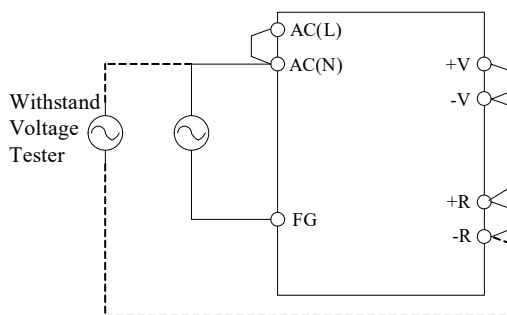

(B) HMS80, HMS100, HMS150

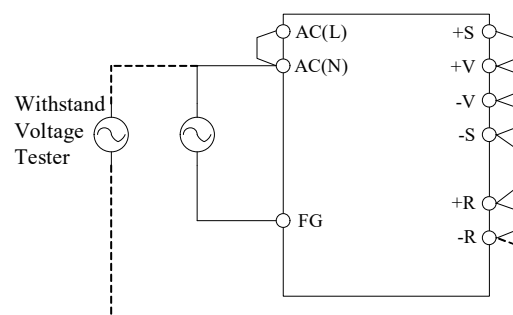

- Output - FG : 500VAC, 1min (20mA)

(A) HMS50

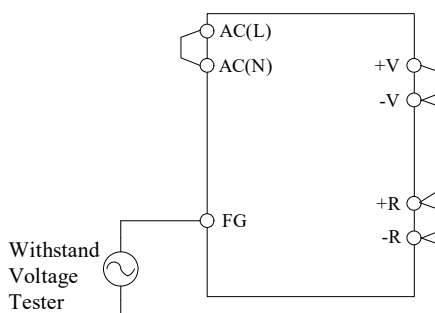

(B) HMS80, HMS100, HMS150

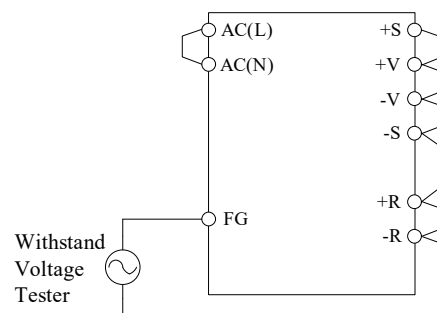

Note 1 : This product have monolithic ceramic capacitor in secondary circuit to Frame Ground.
 Some of the withstand voltage tester may generate high voltage at the matching with monolithic ceramic capacitor and may cause the unit damage.
 So, please check the waveform of applied voltage.

Note 2 : In case of using external noise filter, capacitance between "Input and FG" might be increased.
 When testing withstand voltage between "Input and Output", there is a possibility exceeding withstand voltage between "Output and FG" (500VAC). Please check the voltage between "Output and FG".
 If the voltage exceeding withstand voltage, please add external capacitor to "Output and FG". It can decrease the voltage.
 On the other hand, no need to check the voltage in case of "Output and FG" is shorted.

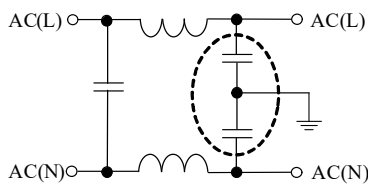

The example of noise filter circuit that may increasing capacitance value between "Input and FG".
 (Capacitance value in dashed line is added.)

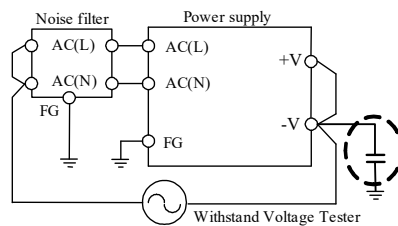

External capacitor adding point or short point
 Even in the case of "+V and FG", there is a similar effect.

6-12. Remote ON/OFF Control (HMS50-150 Option)

Remote ON/OFF control function is available as option with model name followed by /R.
 Using this function allows the user to turn the output on and off without having to turn the AC input off and on. It is controlled by the voltage applied to +R and -R. This circuit is in the Secondary side of the power supply unit. Do not connect in the primary side of power supply unit.
 And this circuit is isolated from the output of power supply unit.

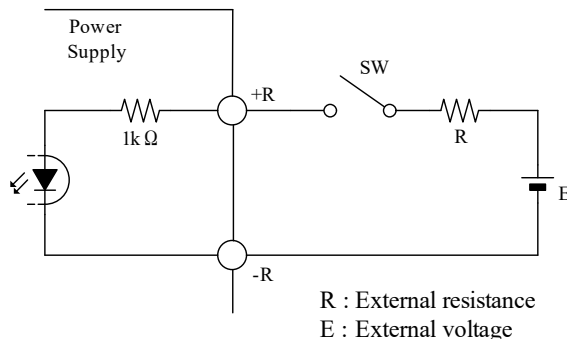

The control mode is shown below.

+R & -R terminal condition	Output condition
SW ON (Higher than 4.5V)	ON
SW OFF (Lower than 0.8V)	OFF

External voltage: E	External resistance: R
4.5 ~ 12.5VDC	No required
12.5 ~ 24.5VDC	1.5k Ω

7. Mounting Method

7-1. Mounting Method

- (1) These models are convection cooling type power supply. In the consideration for the heat radiation and safety.
 Please take a distance more than 15mm between the power supply and the peripheral parts.
 When lining up multiple units, please make sure to place them 15mm or more apart from each other.
- (2) The maximum allowable penetration of mounting screws is 6mm.
- (3) Recommended torque for mounting screw
 HMS50-150 (M3 screw) : 0.49N·m (5.0 kgf·cm)

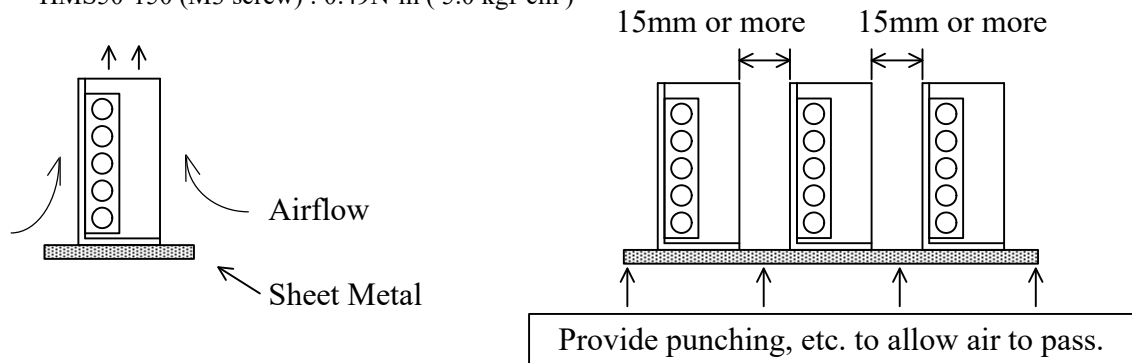

7-2. Output Derating according to the Mounting Directions

Recommend standard mounting is direction (A). Direction (B), (C) and (D) are also possible. Please contact our sales office for other mounting directions.

Refer to the derating below. Please do not use mounting direction (E), where the PCB will be on the topside and heat will be trapped inside the unit. Load (%) is percent of maximum output power or maximum output current, do not exceed its derating of maximum load.

■ Mounting direction

Standard Mounting

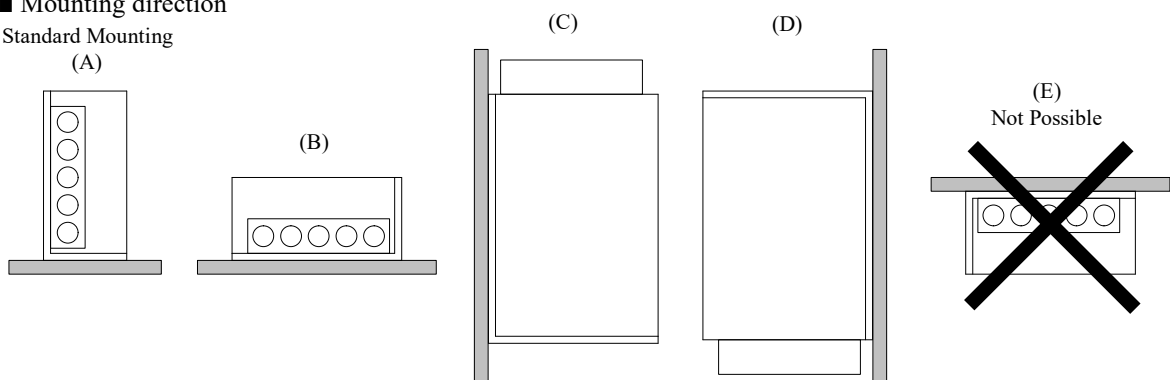

■ **Output Derating**

● **HMS50 (Include option model /R)**

• **AC input**

85 VAC \leq Vin \leq 265 VAC

Ta (°C)	Load (%)		
	Mounting (A)	Mounting (B), (D)	Mounting (C)
-10 - +40	100	100	100
50	100	76	73
60	60	53	46
70	20	30	20

◆ Mounting (A)
 ■ Mounting (B),(D)
 ▲ Mounting (C)

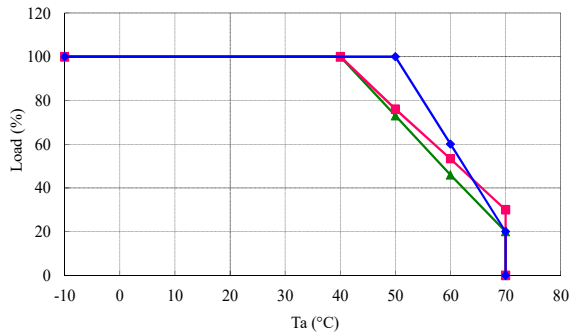

75 VAC \leq Vin < 85 VAC

(Operation time within 20 seconds.)

Ta (°C)	Load (%)		
	Mounting (A)	Mounting (B), (D)	Mounting (C)
-10 - +50	60	60	60
60	60	53	46
70	20	30	20

◆ Mounting (A)
 ■ Mounting (B),(D)
 ▲ Mounting (C)

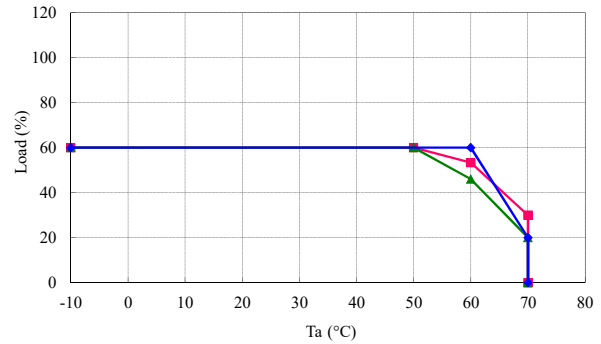

• **DC input**

110 VDC < Vin < 370 VDC

Ta (°C)	Load (%)		
	Mounting (A)	Mounting (B), (D)	Mounting (C)
-10 - +40	100	100	100
50	100	76	73
60	60	53	46
70	20	30	20

◆ Mounting (A)
 ■ Mounting (B),(D)
 ▲ Mounting (C)

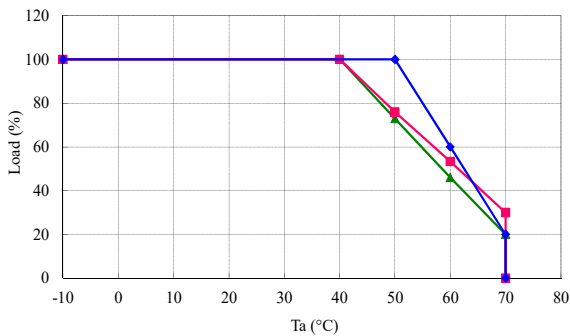

80 VDC < Vin < 110 VDC

Ta (°C)	Load (%)		
	Mounting (A)	Mounting (B), (D)	Mounting (C)
-10 - +40	80	80	80
50	80	61	58
60	48	42	37
70	16	24	16

◆ Mounting (A)
 ■ Mounting (B),(D)
 ▲ Mounting (C)

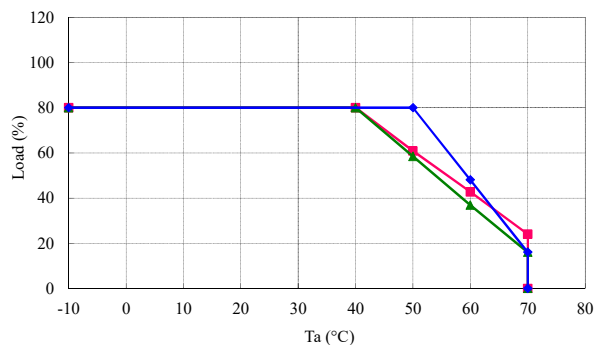

• **HMS80** (Include option model /R)

• AC input

85 VAC \leq Vin \leq 265 VAC

Ta (°C)	Load (%)		
	Mounting (A)	Mounting (B),(D)	Mounting (C)
-10 - +45	100	100	100
50	100	90	86
60	80	70	60
70	60	40	20

◆ Mounting (A)
 ■ Mounting (B),(D)
 ▲ Mounting (C)

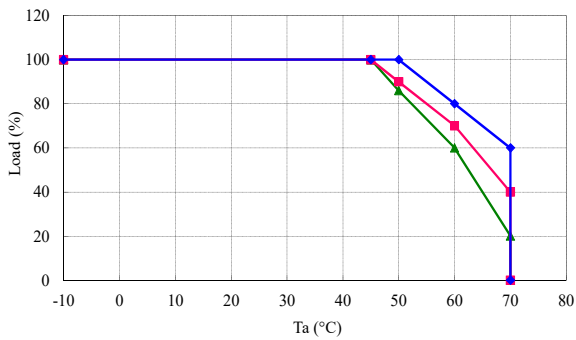

75 VAC \leq Vin < 85 VAC

(Operation time within 20 seconds.)

Ta (°C)	Load (%)		
	Mounting (A)	Mounting (B),(D)	Mounting (C)
-10 - +60	60	60	60
70	60	40	20

◆ Mounting (A)
 ■ Mounting (B),(D)
 ▲ Mounting (C)

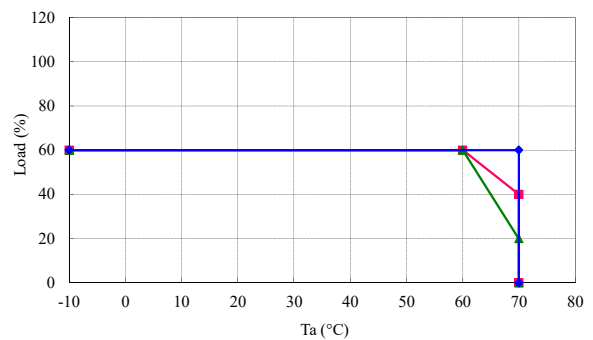

• DC input

110 VDC \leq Vin \leq 370 VDC

Ta (°C)	Load (%)		
	Mounting (A)	Mounting (B),(D)	Mounting (C)
-10 - +45	100	100	100
50	100	90	86
60	80	70	60
70	60	40	20

◆ Mounting (A)
 ■ Mounting (B),(D)
 ▲ Mounting (C)

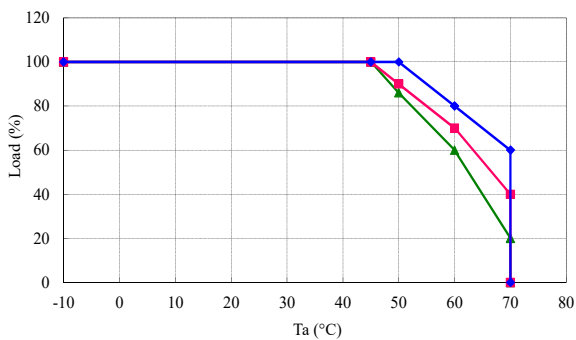

80 VDC \leq Vin < 110 VDC

Ta (°C)	Load (%)		
	Mounting (A)	Mounting (B),(D)	Mounting (C)
-10 - +45	80	80	80
50	80	72	69
60	64	56	48
70	48	32	16

◆ Mounting (A)
 ■ Mounting (B),(D)
 ▲ Mounting (C)

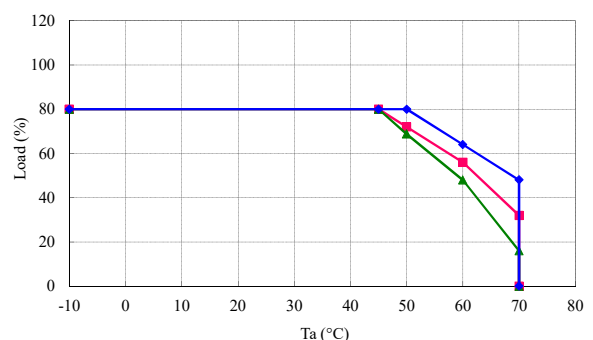

● **HMS100** (Include option model /R)

• AC input

85 VAC ≤ Vin ≤ 265 VAC

*Refer to dotted line for output derating curve, when input voltage range is “85 ≤ Vin < 90” for the MOUNTING A.

Ta (°C)	Load (%)			
	Mounting (A)	Mounting (B)	Mounting (C)	Mounting (D)
-10 - +30	100	100	100	100
35	100	100	92	100
50	100	65	65	65
60	60	37	37	42
70	20	10	10	20

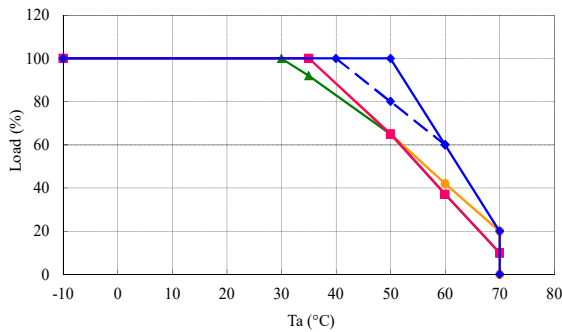

75 VAC ≤ Vin < 85 VAC

(Operation time within 20 seconds.)

Ta (°C)	Load (%)		
	Mounting (A)	Mounting (B),(C)	Mounting (D)
-10 - +50	60	60	60
60	60	37	42
70	20	10	20

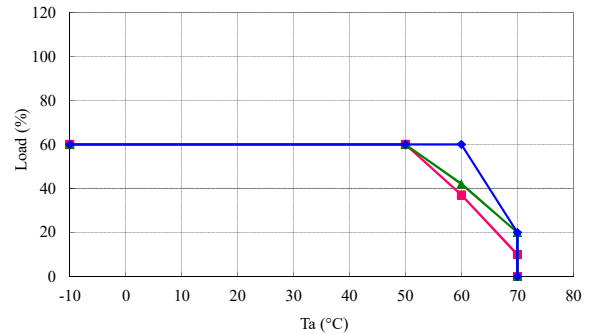
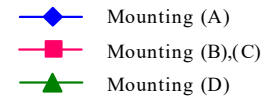

• DC input

110 VDC ≤ Vin ≤ 370 VDC

Ta (°C)	Load (%)			
	Mounting (A)	Mounting (B)	Mounting (C)	Mounting (D)
-10 - +30	100	100	100	100
35	100	100	92	100
50	100	65	65	65
60	60	37	37	42
70	20	10	10	20

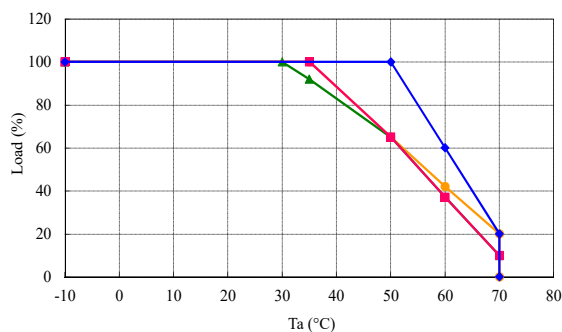

80 VDC ≤ Vin < 110 VDC

Ta (°C)	Load (%)			
	Mounting (A)	Mounting (B)	Mounting (C)	Mounting (D)
-10 - +30	80	80	80	80
35	80	80	74	80
50	80	52	52	52
60	48	30	30	34
70	16	8	8	16

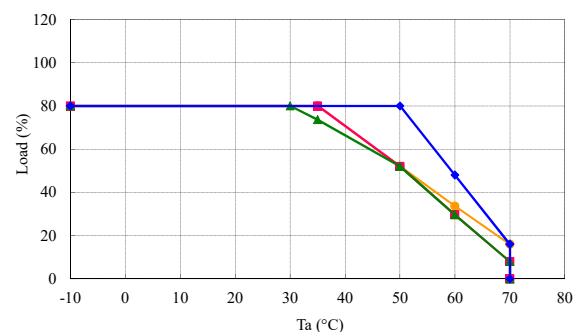

●HMS150 (Include option model /R)

•AC input

85 VAC ≤ Vin ≤ 265 VAC

*Refer to dotted line for output derating curve, when input voltage range is “85≤Vin<90” for the MOUNTING A.

Ta (°C)	Load (%)	
	Mounting (A)	Mounting (B), (C), (D)
-10 - +30	100	100
50	100	60
60	60	35
70	20	10

◆ Mounting (A)
 ■ Mounting (B),(C),(D)

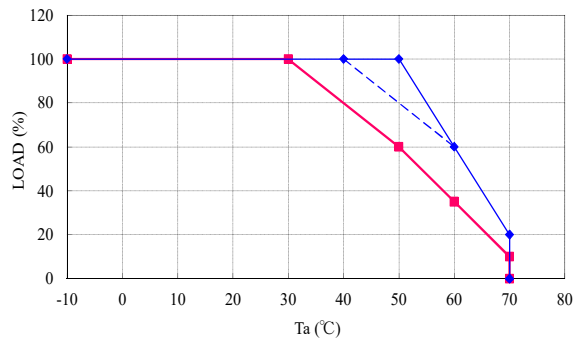

75 VAC ≤ Vin < 85 VAC

(Operation time within 20 seconds.)

Ta (°C)	Load (%)	
	Mounting (A)	Mounting (B), (C), (D)
-10 - +50	60	60
60	60	35
70	20	10

◆ Mounting (A)
 ■ Mounting (B),(C),(D)

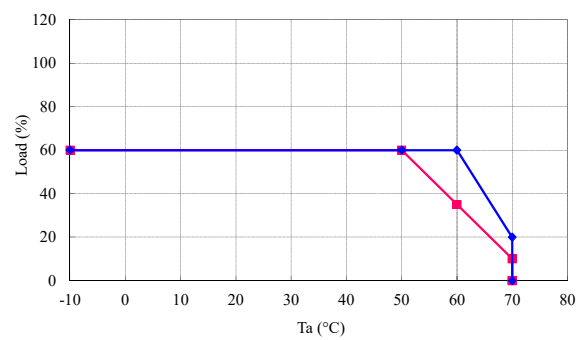

•DC input

95 VDC ≤ Vin ≤ 370 VDC

Ta (°C)	Load (%)	
	Mounting (A)	Mounting (B), (C), (D)
-10 - +30	100	100
50	100	60
60	60	35
70	20	10

◆ Mounting (A)
 ■ Mounting (B),(C),(D)

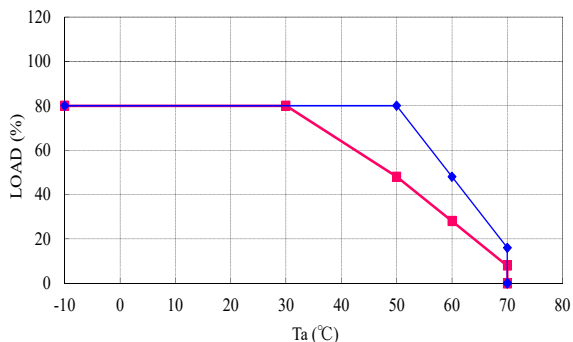

80 VDC ≤ Vin < 95 VDC

Ta (°C)	Load (%)	
	Mounting (A)	Mounting (B), (C), (D)
-10 - +30	80	80
50	80	48
60	48	28
70	16	8

◆ Mounting (A)
 ■ Mounting (B),(C),(D)

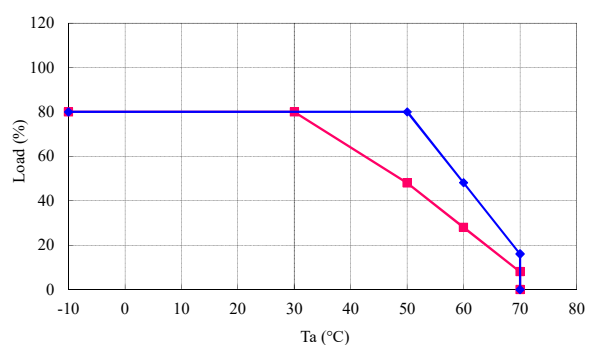

8. Wiring Method

- (1) The output load line and input line shall be separated, and use all lines as thick and short as possible to make lower impedance. The output load line and input line shall be twisted or use shielded wire to improve noise sensitivity.
- (2) Remote sensing lines and remote ON/OFF control lines shall be twisted and separated from the output lines.
- (3) Noise can be eliminated by attaching a capacitor to the load terminals.
- (4) The recommended wire type, torque and crimp-type terminal :

MODEL	Recommended Wire	Recommended torque	Recommended crimp-type terminal		
			D (MAX)	t (MAX)	Mounting pieces (MAX)
HMS50	AWG14-22	All terminal M3.5 Screws 1.0N·m(10.2kgf·cm)~1.6N·m(16.3kgf·cm)	6.8mm	0.8mm	2 piece
HMS80 HMS100	AWG12-22	Output terminal M3.5 Screws 1.0N·m(10.2kgf·cm)~1.6N·m(16.3kgf·cm)	8.1mm	1.0mm	1 piece
	AWG14-22	Other terminal M3.5 Screws 1.0N·m(10.2kgf·cm)~1.6N·m(16.3kgf·cm)		0.8mm	2 piece
HMS150	AWG10-22	Output terminal M3.5 Screws 1.0N·m(10.2kgf·cm)~1.6N·m(16.3kgf·cm)	8.1mm	1.0mm	1 piece
				0.8mm	2 piece
	AWG14-22	Other terminal M3.5 Screws 1.0N·m(10.2kgf·cm)~1.6N·m(16.3kgf·cm)	6.8mm	0.8mm	2 piece

Note 1 : When using separate loads, use of two pcs. of 0.8mm thick crimp-type terminal is recommended.

Note 2 : For recommended wire type, refer to wire maker recommended allowable current and voltage drop.

Especially for 5V models, output current is large.
 Thick diameter wire is recommended.

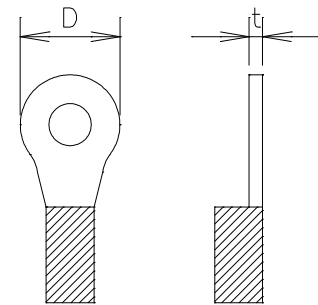

9. The life expectancy

The life of the power supply depends on the life of the built-in aluminum electrolytic capacitor. The life is described in reliability data.

The life of the aluminum electrolytic capacitor varies depending on the method of mounting the power supply, the load current, and the ambient temperature. Please refer to “Electrolytic Capacitor Lifetime”.

Please do not use the product which passed over the life expectancy. There is a risk of unexpected output shutdown and specifications may not be satisfied.

Please contact us for maintenance or exchange the product which passed over the life expectancy.

10. Internal Fuse Rating

Fuse is in Live line.

HMS series uses time-lug fuse.

HMS50-100(F1): AC500V/DC400V 3.15A

HMS150 (F1): AC500V/DC400V 5A

11. External Fuse Rating

Refer to the following fuse rating when selecting the external input fuse.
 Surge current flows when input turn on. Use slow-blow fuse or time-lag fuse. Fast-blow fuse can not be used.
 Fuse rating is specified by inrush current value at input turn on.
 Do not select the fuse according to actual input current (rms.) values.

HMS50-HMS100 : 3.15A
 HMS150 : 5A

12. Before concluding that the unit is at fault...

Before concluding that the unit is at fault, make the following checks.

- (1) Check if the rated input voltage is connected.
- (2) Check if the wiring of input and output is correct.
- (3) Check if the wire size is not too thin.
- (4) Check if the output voltage control (V.ADJ) is properly adjusted.
- (5) Check if the remote sensing terminal is not opened. The output will rise and OVP may be triggered.
- (6) Check if the output current and output power does not over specifications.
- (7) Audible noise can be heard when input voltage waveform is not sinusoidal wave.
- (8) Audible noise can be heard during Dynamic-Load operation.
- (9) Ensure that large capacitor is not connected on the output side.

Please use within maximum capacitance shown below.

If connecting more than the following capacitance value is required, please contact us for details.

MODEL	Maximum external capacitance				
	5V	12V	15V	24V	48V
HMS50	10,000uF	5,000uF		2,000uF	500uF
HMS80 - HMS150	100,000uF	No specification			

13. Warranty Period

This product is warranted for a period of 5 years from the date of shipment.

For damages occurring at normal operation within this warranty period, repair is free of charge.