

HWS 3000G

Instruction Manual

INDEX

	PAGE
BEFORE USING THE POWER SUPPLY UNIT	<u>4-6</u>
1. Model name identification method	<u>7</u>
2. Terminal explanation	<u>7</u>
2-1. Connector pin Configuration and Function	<u>8</u>
2-1-1. CN41、CN42	<u>8-9</u>
2-1-2. CN61	<u>9</u>
2-1-3. CN71	<u>10</u>
3. Connecting method	<u>11</u>
3-1. Basic connection	
(Common connection when using analog function/communication function) ···	<u>11</u>
3-1-1. At time of shipment	<u>11</u>
3-1-2. Remote sensing connection	<u>11</u>
3-1-3. Parallel operation: For constant voltage output mode when using output current balance function	<u>12</u>
3-1-4. Series operation: For constant current output mode when using output voltage balance function	<u>13</u>
3-1-5. Series parallel connection	<u>14</u>
3-1-6. Redundant operation disable function	<u>15</u>
3-1-7. Auxiliary power supply	<u>15</u>
3-2. Connection method when using analog function	<u>16</u>
3-2-1. Leader-Follower function	<u>16</u>
3-2-2. Remote ON/OFF control function	<u>17</u>
3-2-3. Output voltage external control function (Apply external power to CV terminal)	<u>18</u>
3-2-4. Output current external control function (Apply external power to CC terminal)	<u>18</u>
3-2-5. Parallel operation: when using constant current output mode	<u>19</u>
3-2-6. Series operation: when using constant voltage output mode	<u>20</u>
3-2-7. Output voltage monitor function	<u>21</u>
3-2-8. Output current monitor function	<u>21</u>
3-2-9. Constant voltage output mode voltage shortage alarm (VPF signal)· ····	<u>22</u>
3-2-10. Constant current output mode current shortage alarm (CPF signal)· ····	<u>22</u>
3-2-11. Input voltage shortage alarm (ACF signal)	<u>22</u>
3-3. Connection method when using communication function	<u>23</u>
3-3-1. Connection method when using multiple power supplies in conjunction·	<u>23</u>
3-3-2. Case for use with one power supply	<u>24</u>
3-3-3. Cases for changing power output settings & checking operation history·	<u>24</u>

	PAGE
4. Notes on wiring	<u>25</u>
4-1. Input/output wiring	<u>25</u>
4-2. Signal wiring	<u>26</u>
5. Installation method and notes	<u>27</u>
5-1. Mounting direction	<u>27</u>
6. Functional explanation and notes	<u>28</u>
6-1. Input voltage	<u>28</u>
6-2. Input inrush current	<u>28</u>
6-3. Variable output voltage (variable constant voltage output setting value)	<u>28</u>
6-3-1. Variable with built-in output voltage adjustment trimmer	<u>28</u>
6-3-2. Variable by external power (CV terminal external voltage applied)	<u>29</u>
6-3-3. Variable by external power (CV terminal external current applied)	<u>29</u>
6-3-4. Variable by communication	<u>29</u>
6-4. Variable output current (variable constant current output setting value)	<u>30</u>
6-4-1. Variable by external power (CC terminal external voltage applied)	<u>30</u>
6-4-2. Variable by external power (CC terminal external current applied)	<u>31</u>
6-4-3. Variable by communication	<u>31</u>
6-5. Over voltage protection (OVP)	<u>31</u>
6-6. Over current protection (OCP)	<u>31</u>
6-7. Output ripple & noise	<u>32</u>
6-8. Remote sensing (+S, -S terminal)	<u>32</u>
6-9. Parallel operation	<u>33</u>
6-9-1. Parallel operation to increase output current	<u>33</u>
6-9-2. N+1 redundant operation	<u>34</u>
6-9-3. Backup power source (1+1 redundant operation)	<u>35</u>
6-9-4. Leader-Follower connection	<u>35</u>
6-10. Series operation	<u>36</u>
6-10-1. Series operation for increasing output voltage	<u>36</u>
6-10-2. Series operation for plus/minus output	<u>37</u>
6-10-3. Leader-Follower connection	<u>37</u>
6-11. Redundant operation disable function	<u>38</u>
6-12. AUX output	<u>38</u>
6-13. Remote ON/OFF control	<u>39</u>
6-14. Output voltage monitor function	<u>40</u>
6-15. Output current monitor function	<u>40</u>

	PAGE
6-16. Constant voltage output mode voltage shortage alarm (VPF signal)	41
6-17. Constant current output mode current shortage alarm (CPF signal).....	41
6-18. Input voltage shortage alarm (ACF signal).....	42
6-19. Communication function	42
6-20. Isolation test	43
6-21. Withstand voltage.....	44-45
7. Block diagram	46
8. Sequence time chart	47
9. External fuse rating	48
10. Before concluding that the unit is at fault... ..	48
11. The life expectancy	49
12. Warranty period	49
13. CE MARKING / UKCA MARKING	49

BEFORE USING THE POWER SUPPLY UNIT

Be sure to read this instruction manual thoroughly before using this product. Pay attention to all cautions and warnings before using this product. Incorrect usage could lead to an electrical shock, damage to the unit or a fire hazard.

DANGER

1. Never use this product in locations where flammable gas or ignitable substances are present.

INSTALLATION WARNING

1. When installing, ensure that work is done in accordance with the instruction manual. When installation is improper, there is risk of electric shock and fire.
2. Installation shall be done by Service personnel with necessary and appropriate technical training and experience. There is a risk of electric shock and fire.
3. Do not cover the product with cloth or paper etc. Do not place anything flammable around. This might cause damage, electric shock or fire.

WARNING ON USE

1. Do not touch this product or its internal components while circuit in operation, or shortly after shutdown. You may receive a burn.
2. While this product is operating, keep your hands and face away from it as you may be injured by an unexpected situation.
3. For products with no cover, do not touch them as there are high-voltage and high temperature parts inside. Touching them might cause injury such as electric shock or burn.
4. There are cases where high voltage charge remains inside the product. Therefore, do not touch even if they are not in operation as you might get injured due to high voltage and high temperature. You might also get electric shock or burn.
5. Do not make unauthorized changes to this product nor remove the cover as you might get an electric shock or might damage the product. We will not be held responsible after the product has been modified, changed or dis-assembled.
6. Do not use this product under unusual condition such as emission of smoke or abnormal smell and sound etc. Please stop using it immediately and shut off the product.
It might lead to fire and electric shock. In such cases, please contact us. Do not attempt repair by yourself, as it is dangerous for the user.
7. Do not operate and store these products in environments where condensation occurs due to moisture and humidity.
It might lead fire and electric shock.
8. Do not drop or apply shock to this product. It might cause failure. Do not operate these products mechanical stress is applied.

CAUTION ON MOUNTING

1. Confirm connections to input/output terminals are correct as indicated in the instruction manual before switching on.
2. Input voltage, Output current, Output power, ambient temperature and ambient humidity should be kept within specifications, otherwise the product will be damaged.
3. Input line, please use the wires as short and thick as possible.
4. Do not use this product in special environment with strong electromagnetic field, corrosive gas or conductive substances and direct sunlight, or places where product is exposed to water or rain.
5. Mount this product properly in accordance with the instruction manual, mounting direction and shall be properly be ventilated.
6. Please shut down the input when connecting input and output of the product.
7. When installing in environment where conductive foreign, dust and liquid may be present, please consider penetration of above foreign material in the power supply by installing filter, to prevent trouble or malfunction.
8. Not for use in salt water-wet locations.
9. Suitable for mounting on concrete or other non-combustible surfaces only.
10. This open type PECS does not provide comprehensive mitigation for fire hazards. It is intended to be installed inside a supplementary enclosure or in a restricted access area which provides appropriate.
11. This open type PECS does not provide protective means for access to hazardous live parts. It is intended to be installed inside a supplementary enclosure or in a restricted access area which provides.
12. Intended to be used only in areas without combustible materials.
13. No touch of conductive surface of cooling fan due to hazard voltage may appear.

CAUTION ON USE

1. Product individual notes are shown in the instruction manual. If there is any difference with common notes individual notes shall have priority.
2. Before using this product, be sure to read the catalog and instruction manual. There is risk of electric shock or damage to the product or fire due to improper use.
3. Input voltage, Output current, Output power, ambient temperature and ambient humidity should be kept within specifications, otherwise the product will be damaged, or cause electric shock or fire.
4. If the built-in fuse is blown, do not use the product even after replacing the fuse, as there is risk of abnormality inside. Be sure to request repair to our company.
5. For products without built-in protection circuit (element, fuse, etc.), insert fuse at the input to prevent smoke, fire during abnormal operation.
As for products with built-in protection circuit, depending on usage conditions, built-in protection circuit might not work. It is recommended to provide separate proper protection circuit.
6. For externally mounted fuse do not use other fuses aside from our specified and recommended fuse.
7. This product was made for general purpose electronic equipment use and is not designed for applications requiring high safety (such as extremely high reliability and safety requirements. Even though high reliability and safety are not required, this product should not be used directly for applications that have serious risk for life and physical safety.
Take sufficient consideration in fail-safe design (such as providing protective circuit or protective device inside the system, providing redundant circuit to ensure no instability when single device failure occurs).
8. When used in environments with strong electromagnetic field, there is possibility of product damage due to malfunction.
9. When used in environment with corrosive gas (hydrogen sulfide, sulfur dioxide, etc.) , there is possibility that they might penetrate the product and lead to failure.
10. When used in environments where there is conductive foreign matter or dust, there is possibility of product failure or malfunction.
11. Provide countermeasure for prevention of lightning surge voltage as there is risk of damage due to abnormal voltage.
12. Connect together the frame ground terminal of the product and the ground terminal of the equipment for safety and noise reduction. If these ground is not connected together, there is risk of electric shock.
13. Parts with lifetime specifications (built-in fan electrolytic capacitor) are required to be replaced periodically. Set the overhaul period depending on the environment of usage and perform maintenance.
Also, note that there are cases when EOL products cannot be overhauled.
14. Take care not to apply external abnormal voltage to the output. Especially, applying reverse voltage or overvoltage more than the rated voltage to the output might cause failure, electric shock or fire.

NOTE

1. Take note that traces of sheet metal processing be left in our power supplies.
2. When disposing product, follow disposal laws of each municipality.
3. Published EMI (CE, RE) or immunity is the result when measured in our standard measurement conditions and might not satisfy specification when mounted and wired inside end-user equipment.
Use the product after sufficiently evaluating at actual end-user equipment.
4. When exporting our products, apply for necessary permissions as required by rules and regulations of Foreign Exchange and foreign Trade Control Act.
5. Catalogue, contents of the instruction manual may be changed without a prior notice. Refer to latest catalogue or instruction manual.
6. Reproduction or reprinting the instruction manual or its portion is forbidden without our permission.

LONG-TERM STORAGE METHOD AND PERIOD

1. Please keep the product in carton box.
2. Please do not apply excessive vibration, shock or mechanical stress applied directly to the product.
3. Please keep away from direct sunlight.
4. For long-term storage temperature and humidity, the following conditions shall be used as a guideline :
 - Temperature range : 5°C~30°C
 - Humidity range : 40%~60%RH
 - Please keep away from the places where temperature and humidity can change drastically.
 - It can cause condensation on the product or deterioration.
5. For long-term storage period, we recommend to use within 2 years after receiving the product.
 - < Soldering and PCB mounted products : On Board, Power Module and etc >
 - For products that have been received for more than 1 year, please check lead oxidation and solderability.
 - In addition, SMD type products may have MSL (Moisture Sensitivity Level) provision.
 - Please be sure to read the instruction manual and delivery specifications.
 - < Unit type or PCB type of products : the product is used an aluminium electrolytic capacitor >
 - There is tendency that the leakage current of an aluminium electrolytic capacitor may increase when stored without using for a long time. This phenomenon can be improved by applying voltage to the aluminium electrolytic capacitor to reduce the increased leakage current through the self-recovery effect of the electrolyte.
 - For reference, before using products that have been stored for a very long time, please warm-up first for 30 minutes or more without taking load.
 - < Criterion of warm up voltage condition >
 - (1)Implementation period : 1 year or above after the delivery
 - (2)Electrical continuity condition
 - Input voltage : Rating
 - Load : 0A
 - Ambient temperature : Normal temperature
 - Time : 30 minutes or more

1. Model name identification method

HWS 3000G - 24 / □

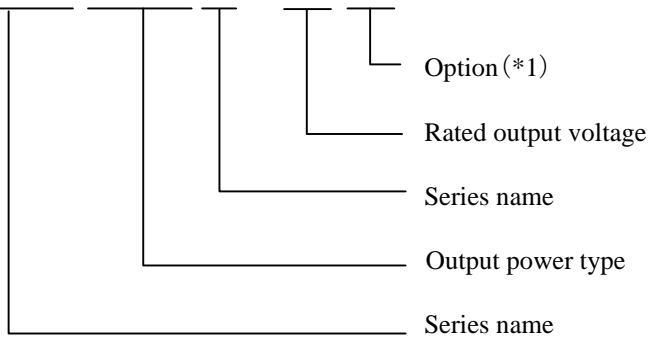

(*1)

Blank: Standard

/HD : Refer to the specifications for details

•With coating on both sides of PCB

•Designed to meet 「MIL-STD-810G」
(Vibration • Shock)

2. Terminal explanation

Top side screw (Shipment condition)

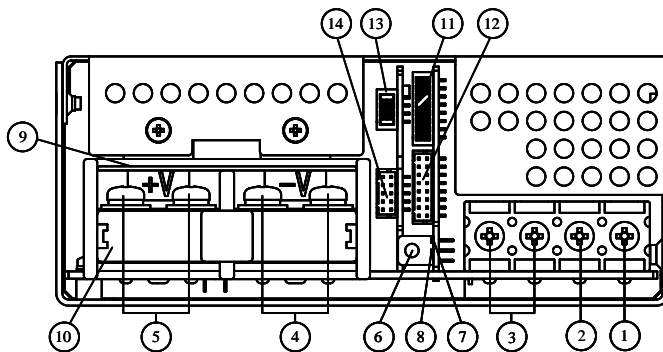

Front side screw

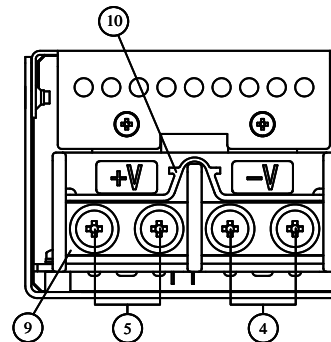

- ① N : Input terminal Neutral line (Fuse in line) (M4 screw) *Basic insulation between FG
- ② L : Input terminal Live line (Fuse in line) (M4 screw) *Basic insulation between FG
- ③ ⚡ : Earth terminal (FG) (M4 screw) *Connected to the power supply case inside the power supply
- ④ -V : -Output terminal (62.5A max. / terminal, M5 screw) *Basic insulation between FG
- ⑤ +V : +Output terminal (62.5A max. / terminal, M5 screw) *Basic insulation between FG
- ⑥ Output voltage adjustment trimmer
- ⑦ Output monitoring indicator (Green LED lights up when power is output)
(Flashes when output voltage is 60V or more after input voltage cutoff)
- ⑧ Communication display LED (yellow LED flashes during communication)
- ⑨ Terminal cover 1
- ⑩ Terminal cover 2
- ⑪ Signal connector CN41 *Functional insulation between FG
- ⑫ Signal connector CN42 *Functional insulation between FG
- ⑬ Signal connector CN61 *Basic insulation between FG
- ⑭ Signal connector CN71 *Functional insulation between FG

2-1. Connector pin Configuration and Function

[TOP](#)

2-1-1. CN41, CN42

Terminals with the same name, CN41 and CN42, are connected inside the power supply.

If you short the terminals on the CN41 side, the terminals on the CN42 side will also short.

*Please note that pin No. 5 has different functions between CN41 and CN42.

CN41 and CN42 are isolated from the power input and output circuits.

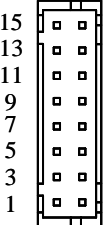
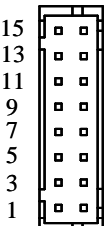
Configuration	No.	Pin name	Function
 <p style="text-align: center;">CN41</p>	1	-D	Differential data - for RS-485
	2	+D	Differential data + for RS-485
	3	-DR	Termination resistor terminal for RS-485
	4	DG	Ground for -D,+D,A/I,HL (internally connected to AG terminal.)
	5	A/I	Address assignment input terminal
	6	DG	Ground for -D,+D,A/I,HL (internally connected to AG terminal.)
	7	HL	Redundant operation invalid terminal
	8	PWR	External power supply terminal for communication By applying the communication power supply voltage externally, settings and operation history can be read through communication without applying an AC input voltage.
	9	-R	Remote ON/OFF control terminal
	10	+R	Remote ON/OFF control terminal
	11	AG	Ground for CB,VB,CC,CV (internally connected to DG terminal.)
	12	AG	Ground for CB,VB,CC,CV (internally connected to DG terminal.)
	13	CB	Current balance terminal. (For current balancing in parallel operation.)
	14	VB	Voltage balance terminal (For voltage balancing in series operation)
	15	CC	Output current external control terminal.
	16	CV	Output voltage external control terminal.
Configuration	No.	Pin name	Function
 <p style="text-align: center;">CN42</p>	1	-D	Differential data - for RS-485
	2	+D	Differential data + for RS-485
	3	-DR	Termination resistor terminal for RS-485
	4	DG	Ground for -D,+D,A/O,HL (internally connected to AG terminal.)
	5	A/O	Address assignment output terminal
	6	DG	Ground for -D,+D,A/O,HL (internally connected to AG terminal.)
	7	HL	Redundant operation invalid terminal
	8	PWR	External power supply terminal for communication By applying the communication power supply voltage externally, settings and operation history can be read through communication without applying an AC input voltage.
	9	-R	Remote ON/OFF control terminal
	10	+R	Remote ON/OFF control terminal
	11	AG	Ground for CB,VB,CC,CV (internally connected to DG terminal.)
	12	AG	Ground for CB,VB,CC,CV (internally connected to DG terminal.)
	13	CB	Current balance terminal. (For current balancing in parallel operation.)
	14	VB	Voltage balance terminal (For voltage balancing in series operation)
	15	CC	Output current external control terminal.
	16	CV	Output voltage external control terminal.

[TOP](#)

*CN41、CN42 Connector (JST)

Connector	Housing	Terminal Pin
S16B-PHDSS	PHDR-16VS	SPHD-002T-P0.5 (AWG24 ~ 28) or SPHD-001T-P0.5 (AWG22 ~ 26)

Use maker recommended crimping tool.

Hand Crimping Tool : YRS-620(SPHD-002T-P0.5)(JST) or YC-610R(SPHD-001T-P0.5)(JST)

These are connected by short pieces at time of shipment.

CN41 : -R terminal (Pin No.9) to AG terminal (PinNo.12)

When using a built-in terminating resistor, be sure to use twisted pair wires with characteristic impedance of 100 Ω RS-485 compatible wire material for the +D and -D terminals. (Ex: HK-SB/20276XL LF TAIYO CABLETEC)

Note 1: The characteristic impedance of the wire material varies depending on the manufacturer and the type of wire material. Please contact the wire manufacturer for the characteristic impedance when selecting wire materials.

Note 2: The built-in terminating resistor cannot be used when using twisted pair wires other than RS-485 compatible wires with a characteristic impedance of 100Ω. A terminating resistor that takes impedance matching with the characteristic impedance of the wire into consideration must be externally mounted between the +D and -D terminals of the power supply at the end of the line.

Note 3: Communication stability varies depending on the type and length of the communication line, ambient noise environment, and other factors.

Please evaluate it thoroughly in your environment of use and consider using shielded wires depending on the environment of use.

2-1-2. CN61

Connector for remote sensing.

CN61 is connected to the output of the power supply.

Note: Products with 60 V output and products with 130 V output will have voltages above 60 V.

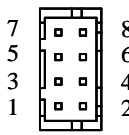
Configuration	No.	Pin name	Function
 <p>CN61</p>	1	-S	Remote sensing terminal for -output side. (For remote sensing function, which compensates for line drop between power supply terminals and load terminals. Connect to -L terminal when remote sensing function unnecessary.)
	2	-L	Local sensing terminal, internally connected to -output terminal. (-L terminal cannot supply load current.)
	3	NC	Do not connect.
	4	NC	Do not connect.
	5	NC	Do not connect.
	6	NC	Do not connect.
	7	+S	Remote sensing terminal for +output side. (For remote sensing function, which compensates for line drop between power supply terminals and load terminals. Connect to +L terminal when remote sensing function unnecessary.)
	8	+L	Local sensing terminal, internally connected to +output terminal. (+L terminal cannot supply load current.)

*CN61 Connector (JST)

Connector	Housing	Terminal Pin
S8B-PHDSS	PHDR-8VS	SPHD-002T-P0.5 (AWG24 ~ 28) or SPHD-001T-P0.5 (AWG22 ~ 26)

Use maker recommended crimping tool.

Hand Crimping Tool : YRS-620(SPHD-002T-P0.5)(JST) or YC-610R(SPHD-001T-P0.5)(JST)

These are connected by short pieces at time of shipment.

-S terminal (Pin No.1) to -L terminal (Pin No.2)

+S terminal (Pin No.7) to +L terminal (Pin No.8)

*The attached short piece is designed for basic insulation between CN61 and FG.

2-1-3. CN71

CN71 are isolated from the power input and output circuits.

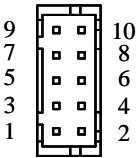
Configuration	No.	Pin name	Function
 <p>CN71</p>	1	AUX	+ output terminal of auxiliary power output
	2	AUX	+ output terminal of auxiliary power output
	3	GND	- output terminal of auxiliary power output (internally connected to DG terminal.)
	4	GND	- output terminal of auxiliary power output (internally connected to DG terminal.)
	5	DG	Ground for L/E,ACF,CPF,VPF (internally connected to GND terminal.)
	6	L/E	Leader machine setting terminal for Leader/Follower operation, short-circuiting with DG terminal sets Leader machine setting.
	7	DG	Ground for L/E,ACF,CPF,VPF (internally connected to GND terminal.)
	8	ACF	Input voltage shortage alarm (Open collector output. Opens when input voltage is lost.)
	9	CPF	Constant current output mode current shortage alarm (Open collector output. Open when output current decreases)
	10	VPF	Constant voltage output mode voltage shortage alarm (Open collector output. Open when the output voltage drops)

*CN71 Connector (JST)

Connector	Housing	Terminal Pin
S10B-PHDSS	PHDR-10VS	SPHD-002T-P0.5 (AWG24 ~ 28) or SPHD-001T-P0.5 (AWG22 ~ 26)

Use SPHD-001T-P0.5 (AWG22 ~ 26) for the AUX and GND terminals, and select a wire with a thickness according to the output current.

Use maker recommended crimping tool.

Hand Crimping Tool : YRS-620(SPHD-002T-P0.5)(JST) or YC-610R(SPHD-001T-P0.5)(JST)

3. Connecting method

[TOP](#)

Pay attention to the input wiring. If it is connected to wrong terminal, the power supply will be damaged.

- Input must be off when making connections.
- Connect terminal to earth (frame ground of the equipment etc.) by thick wire for safety and improvement of Noise sensitivity.

3-1. Basic connection(Common connection when using analog function/communication function)

3-1-1. At time of shipment

Short pieces ① and ② are connected at the time of shipment from the factory.

- ① When not using the remote sensing function (local sensing), short-connect the -S terminal (Pin No.1) and -L terminal (Pin No.2), and short-connect the +S terminal (Pin No.7) and +L terminal (Pin No.8) of CN61.
- ② When not using the remote ON/OFF control function, short-connect the -R terminal (Pin No.9) and AG terminal (Pin No.12) of CN41 or CN42.

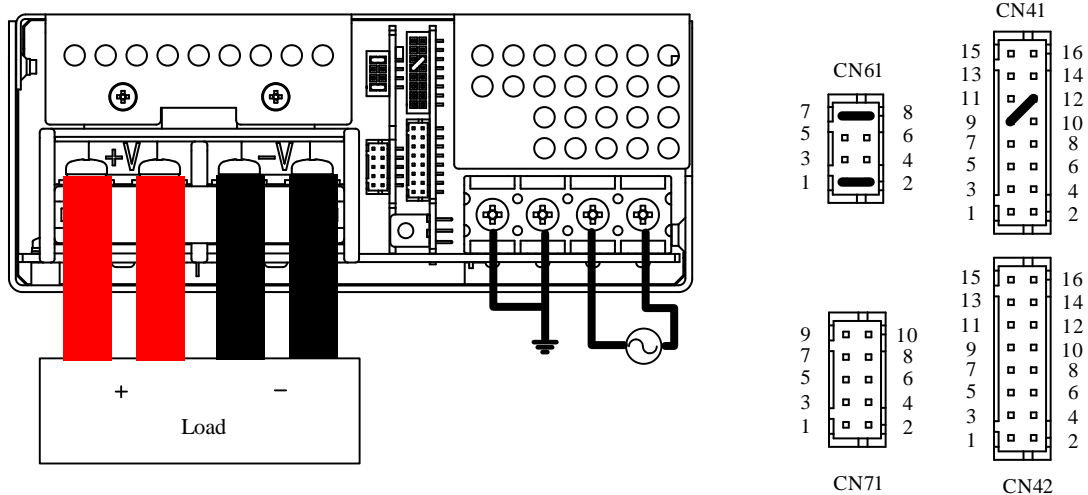

3-1-2. Remote sensing connection

Connect the sensing wire from the +S terminal (pin No. 7) of CN61 to the + side of the load terminal, and from the -S terminal (pin No. 1) of CN61 to the - side of the load terminal.

Use twisted or shielded sensing wires.

Be careful not to remove the load wire screws. Load current may flow through the sensing wires, causing power supply failure.

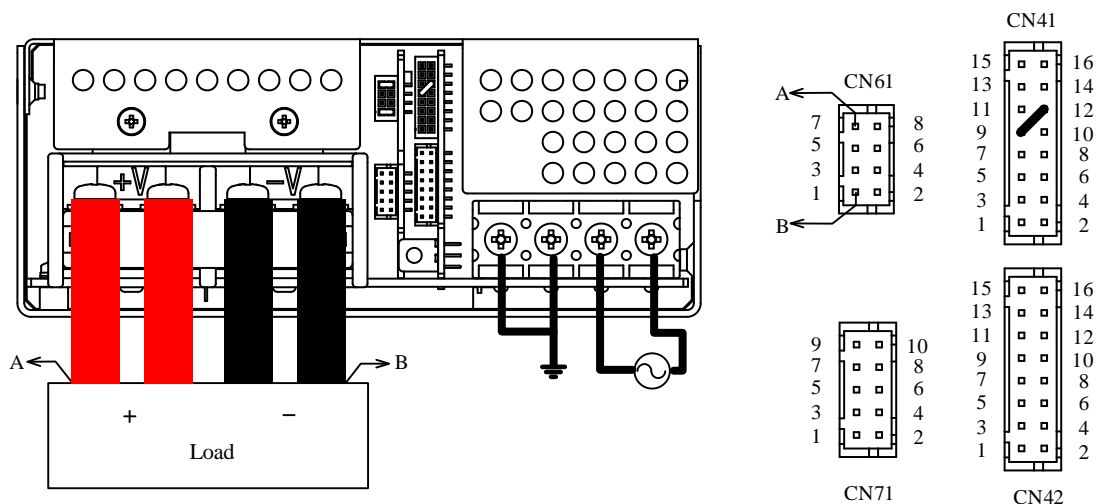

3-1-3. Parallel operation: For constant voltage output mode when using output current balance function

Parallel operation in constant voltage output mode is possible by using the output current balance function.

Connect between the CB terminals (pin No. 13 of CN41 or CN42) and the AG terminals (pin No. 11 or pin No. 12 of CN41 or CN42) of all power supplies operating in parallel.

The wires between CB terminals and AG terminals should be the same length and as short as possible, and twisted or shielded wires should be used.

Make sure that the load wires from each power supply are the same size and length.

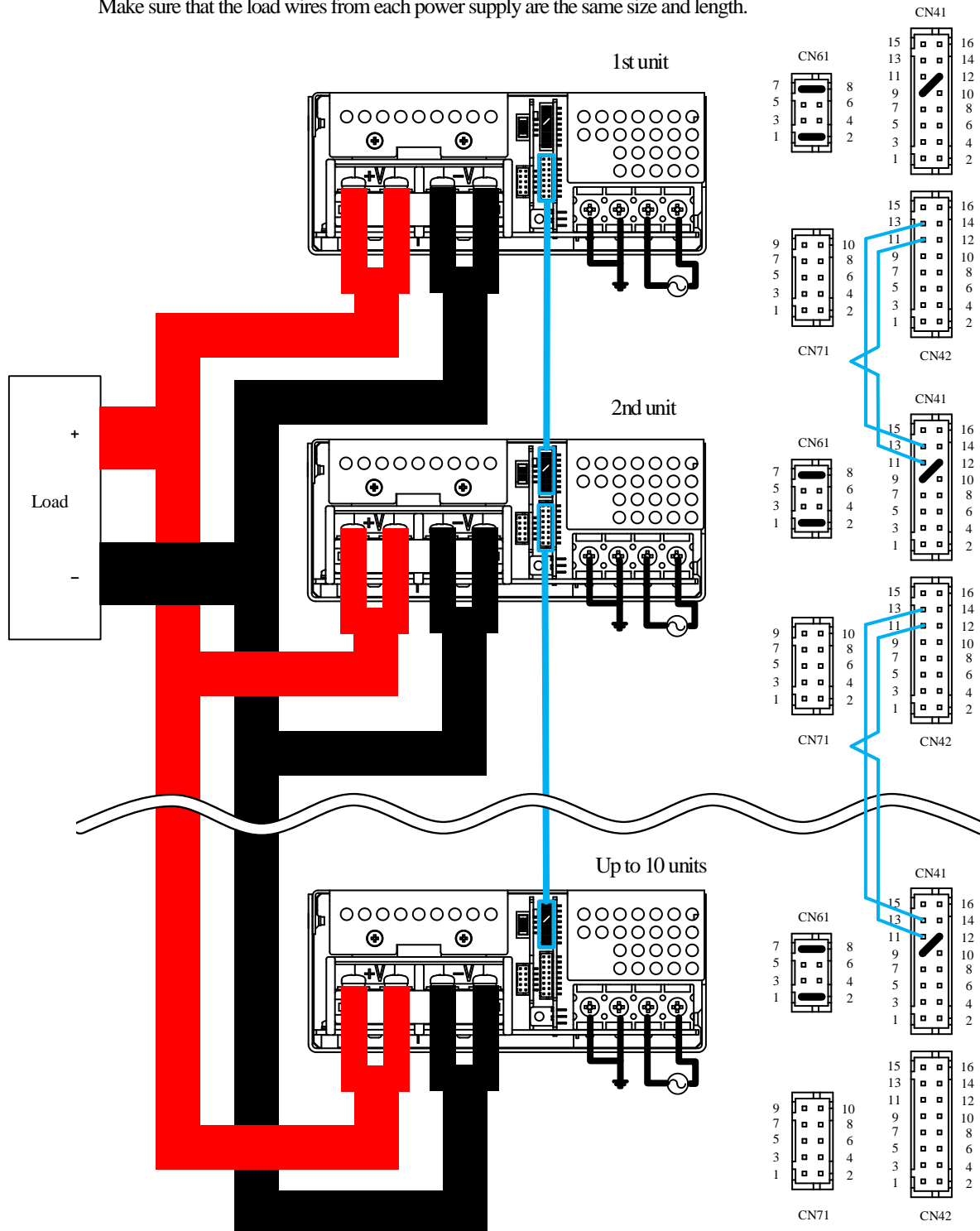

3-1-4. Series operation: For constant current output mode when using output voltage balance function

Series operation in constant current output mode is possible by using the output voltage balance function.

Connect the VB terminals (pin No. 14 of CN41 or CN42) and the AG terminals (pin No. 11 or pin No. 12 of CN41 or CN42) of all power supplies operating in series.

The wires between the VB and AG terminals should be the same length and as short as possible, and twisted or shielded wires should be used.

To protect when one unit stops, connect the HL terminals (CN41 or CN42 pin No. 7) and the DG terminals (CN41 or CN42 pin No. 4 or pin No. 6) of all power supplies.

The wires between HL terminals and DG terminals should be the same length and as short as possible, and twisted or shielded wires should be used.

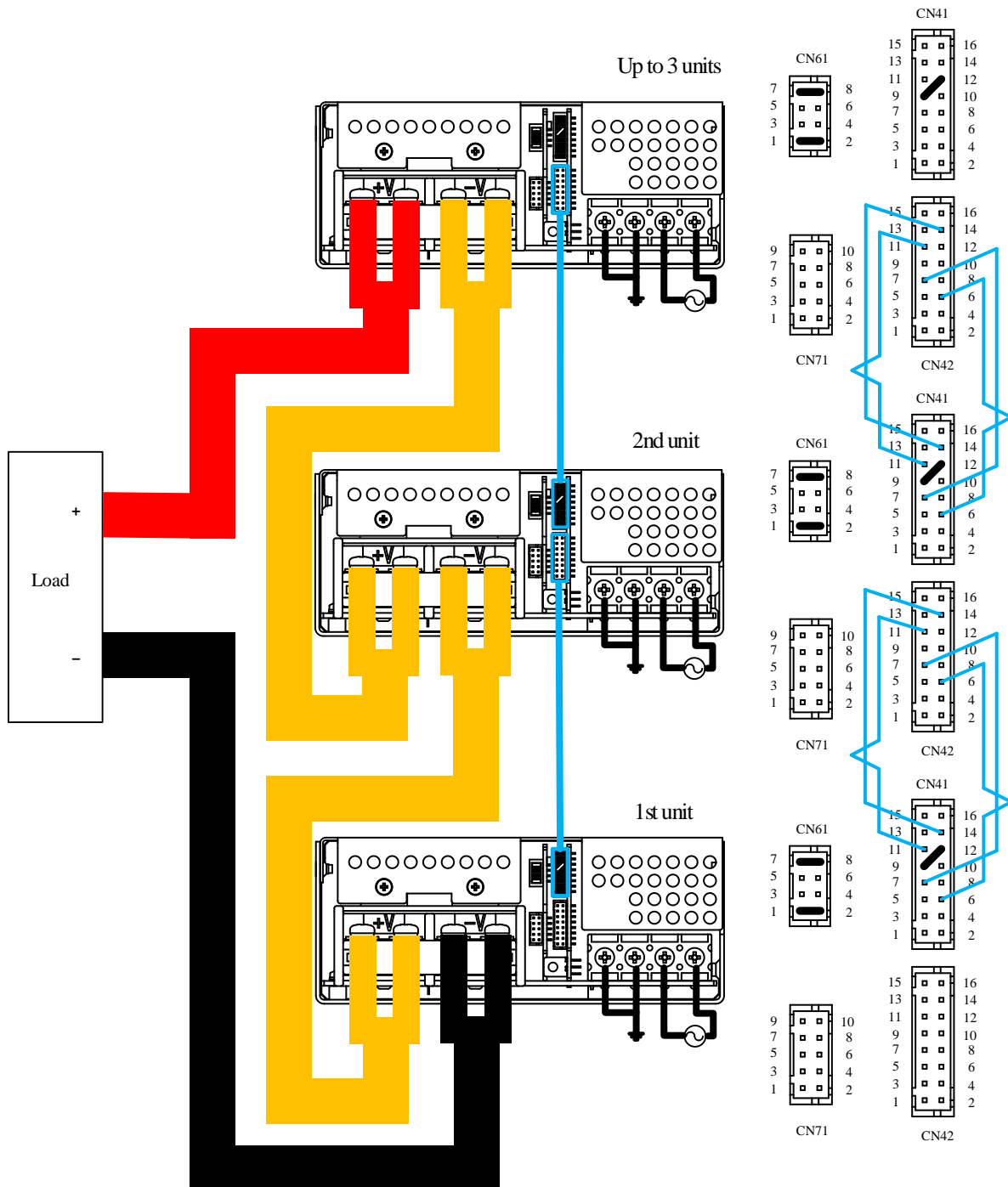

3-1-5. Series parallel connection

When using series-parallel connections, connect the series-connected power supplies in parallel.
 If power supplies connected in parallel are connected in series, the output may become unstable.
 Use load wires from each series-connected power supply that are the same size and length.

Connect between the VB terminals (pin No. 14 of CN41 or CN42) and the AG terminals (pin No. 11 or pin No. 12 of CN41 or CN42) of the power supplies connected in series.

Connect between the CB terminals (pin No. 13 of CN41 or CN42) and the AG terminals (pin No. 11 or pin No. 12 of CN41 or CN42) of all power supplies.

The wires between the VB, CB, and AG terminals should be the same length and as short as possible, and twisted or shielded wires should be used.

To protect when one unit stops, connect the HL terminals (CN41 or CN42 pin No. 7) and the DG terminals (CN41 or CN42 pin No. 4 or pin No. 6) of all power supplies.

The wires between HL terminals and DG terminals should be the same length and as short as possible, and twisted or shielded wires should be used.

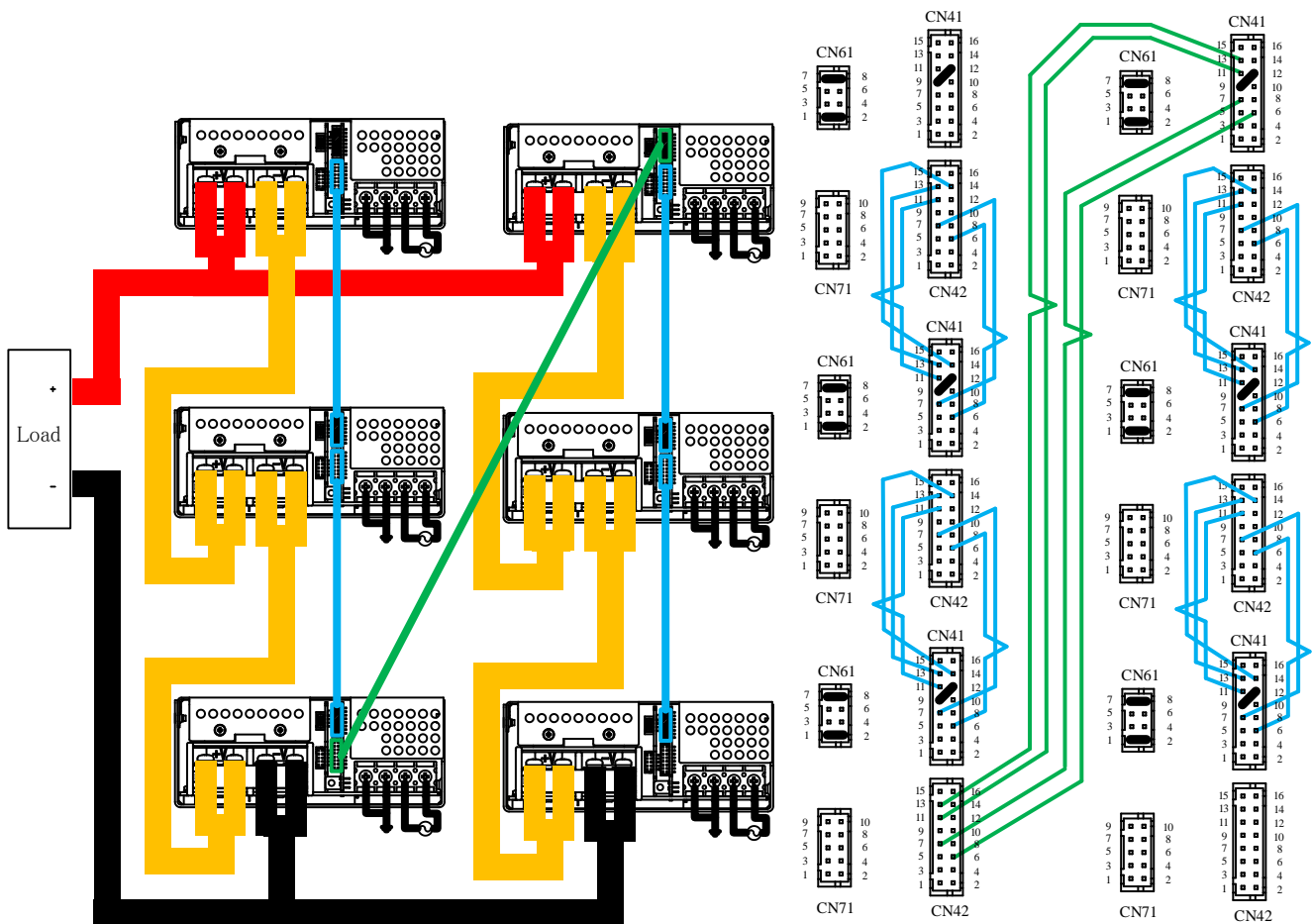

3-1-6. Redundant operation disable function

When linking multiple power supplies, it is possible to disable redundant operation so that all units stop when one unit stops.

Connect the HL terminals (CN41 or CN42 pin No. 7) and the DG terminals (CN41 or CN42 pin No. 4 or pin No. 6) of all power supplies to be linked.

The wires between HL terminals and DG terminals should be the same length and as short as possible, and twisted or shielded wires should be used.

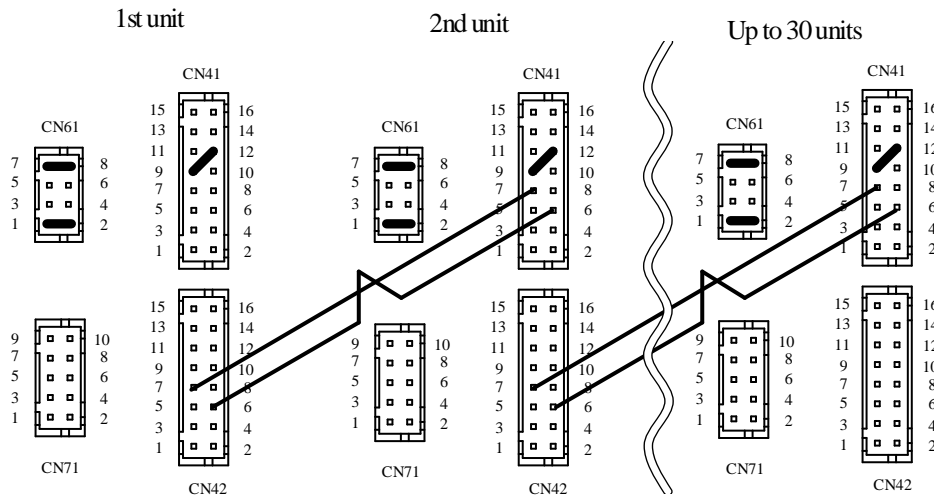

3-1-7. Auxiliary power supply

Connect the AUX terminal (pin No. 1 and pin No. 2) and GND terminal (pin No. 3 and pin No. 4) of CN71 to the external load.

Twist the load wires.

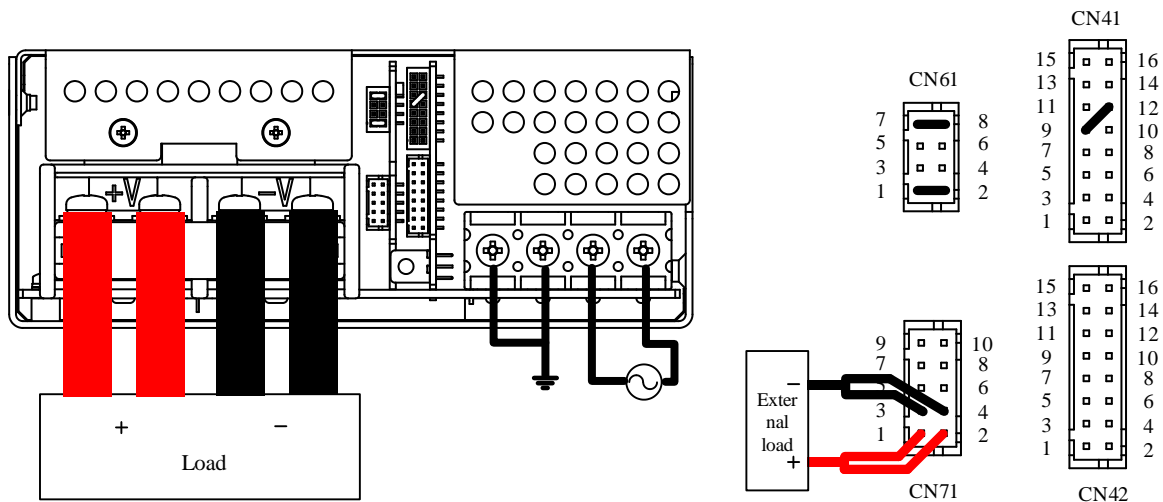

3-2. Connection method when using analog function

[TOP](#)

3-2-1. Leader-Follower function

Leader-Follower control allows multiple power supplies to be linked together with one control.

The controlling side is called the "leader machine" and the controlled side is called the "follower machine."

◆ Pre-configuration

Before connecting multiple power supplies, set up the leader and follower devices.

<Leader machine setting>

Short-circuit between the L/E terminal (CN71 pin No. 6) and the DG terminal (CN71 pin No. 5 or pin No. 7).

<Follower machine setting>

Open the -R terminal (pin No.9 of CN41 and CN42).

◆ Leader/follower connection

Connect the Leader machine to the starting point.

Connect between the +D terminals(CN41 or CN42 pin No.2), between the -D terminals(CN41 or CN42 pin No.1), and between the DG terminals(CN41 or CN42 pin No.4 or pin No.6) of all power supplies. Short between the +D and -DR terminals(CN41 or CN42 pin No.3) of the leader machine and the last follower machine.

The wires between +D terminals, -D terminals, and DG terminals should be the same length and as short as possible, and twisted or shielded wires should be used.

Note: Be sure to use twisted pair wires with characteristic impedance of 100 Ω for the +D and -D terminals, which are compatible with RS-485. See section 2-1-1 for details.

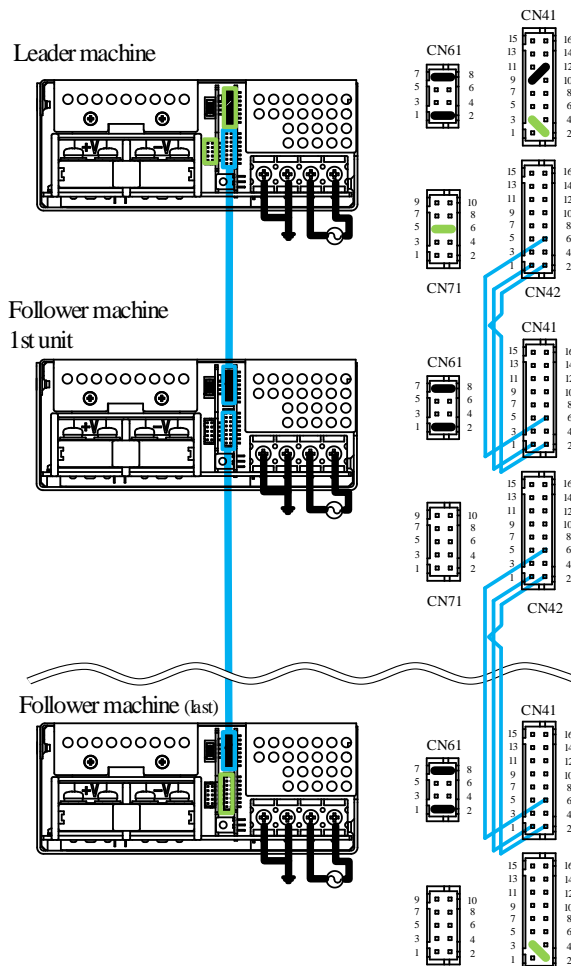

3-2-2. Remote ON/OFF control function

Power output can be controlled ON/OFF using +R terminal (pin No. 10), -R terminal (pin No. 9), and AG terminal (pin No. 11 or pin No. 12) of CN41 or CN42. .

The following three types of ON/OFF control are possible.

1) Power output by applying external voltage

Connect an external voltage source and limiting resistor between +R terminal (pin No. 10) and -R terminal (pin No. 9).

(Use twisted or shielded wires for the ON/OFF control wires.)

2) Power output when short-circuited between terminals

Connect a switch between -R terminal (pin No. 9) and AG terminal (pin No. 11 or pin No. 12).

(Use twisted or shielded wires for the ON/OFF control wires.)

3) Power output when terminals are open

Short-connect between -R terminal (pin No. 9) and AG terminal (pin No. 11 or pin No. 12).

Connect a switch between +R terminal (pin No. 10) and -R terminal (pin No. 9).

(Use twisted or shielded wires for the ON/OFF control wires.)

1) Power output by applying external voltage

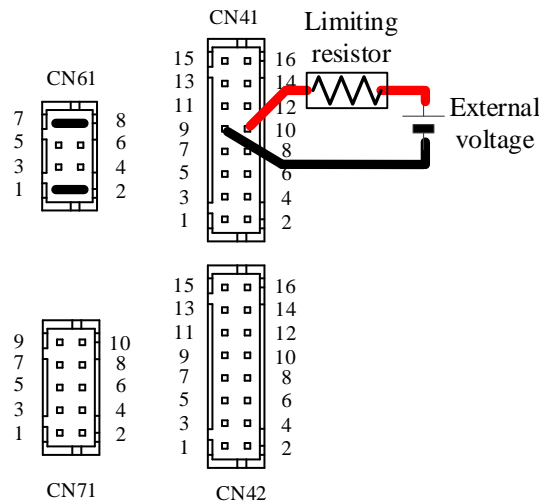

2) Power output when short-circuited between terminals

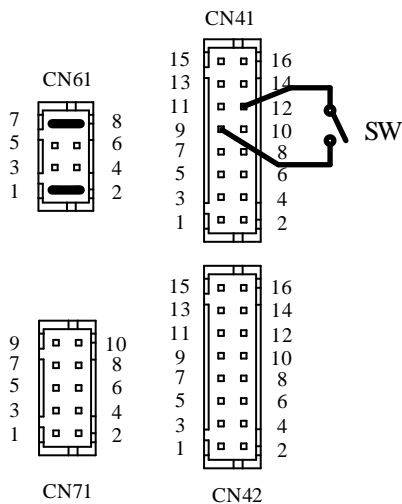

3) Power output when terminals are open

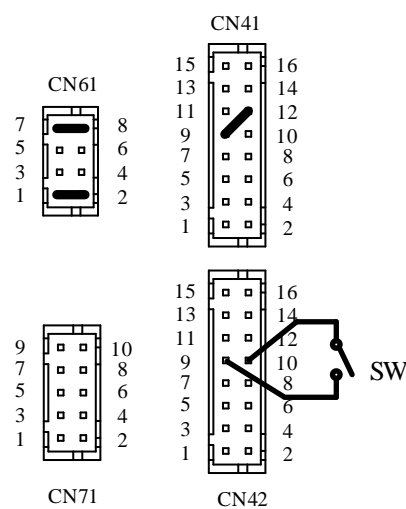

3-2-3. Output voltage external control function (Apply external power to CV terminal)

Connect the external power supply between the CV terminal (pin No. 16 of CN41 or CN42) and the AG terminal (pin No. 11 or pin No. 12 of CN41 or CN42).

Use twisted or shielded signal wires.

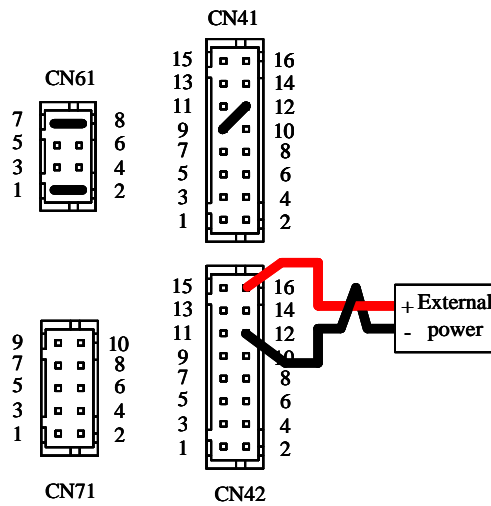

3-2-4. Output current external control function (Apply external power to CC terminal)

Connect the external power supply between the CC terminal (pin No. 15 of CN41 or CN42) and the AG terminal (pin No. 11 or pin No. 12 of CN41 or CN42).

Use twisted or shielded signal wires.

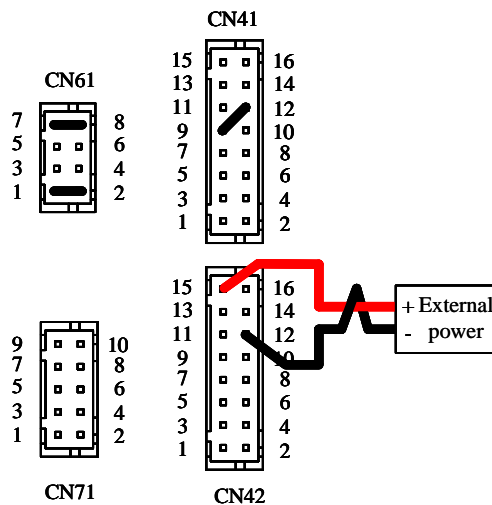

3-2-5. Parallel operation: When using constant current output mode

Connect the CC terminals in a daisy chain and apply an external voltage to the CC terminals.

Connect between the CC terminals (pin No. 15 of CN41 or CN42) and the AG terminals (pin No. 11 or pin No. 12 of CN41 or CN42) of all power supplies operating in parallel. Apply an external voltage between the CC and AG terminals.

The wires between CC and AG terminals should be the same length and as short as possible, and twisted or shielded wires should be used.

Make sure that the load wires from each power supply are the same size and length.

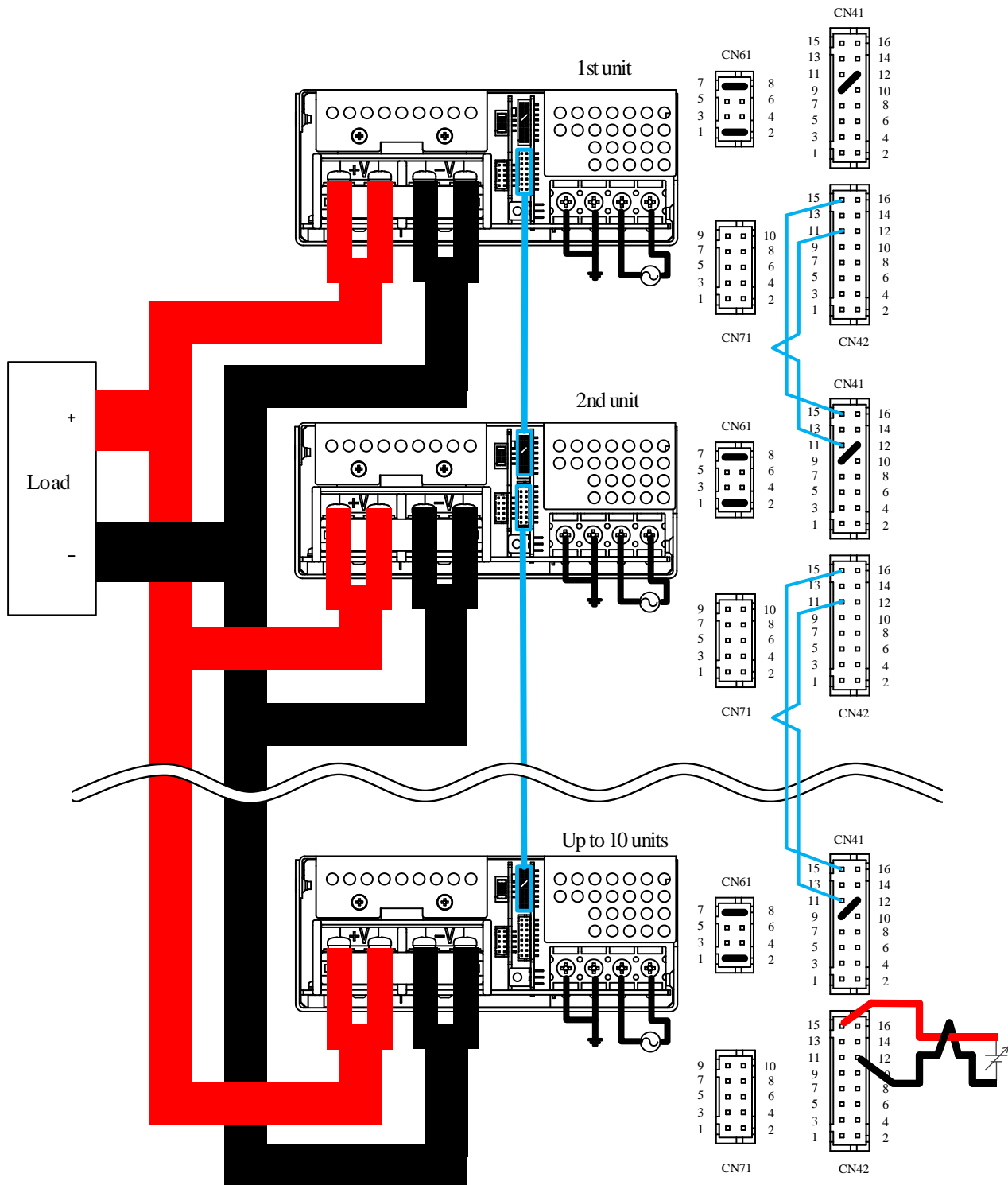

3-2-6. Series operation: When using constant voltage output mode

Connect the CV terminals in a daisy chain and apply an external voltage to the CV terminals.

Connect between the CV terminals (pin No. 16 of CN41 or CN42) and the AG terminals (pin No. 11 or pin No. 12 of CN41 or CN42) of all power supplies operating in parallel. Apply an external voltage between the CV and AG terminals.

The wires between CV and AG terminals should be the same length and as short as possible, and twisted or shielded wires should be used.

To protect when one unit stops, connect the HL terminals (CN41 or CN42 pin No. 7) and the DG terminals (CN41 or CN42 pin No. 4 or pin No. 6) of all power supplies.

The wires between HL terminals and DG terminals should be the same length and as short as possible, and twisted or shielded wires should be used.

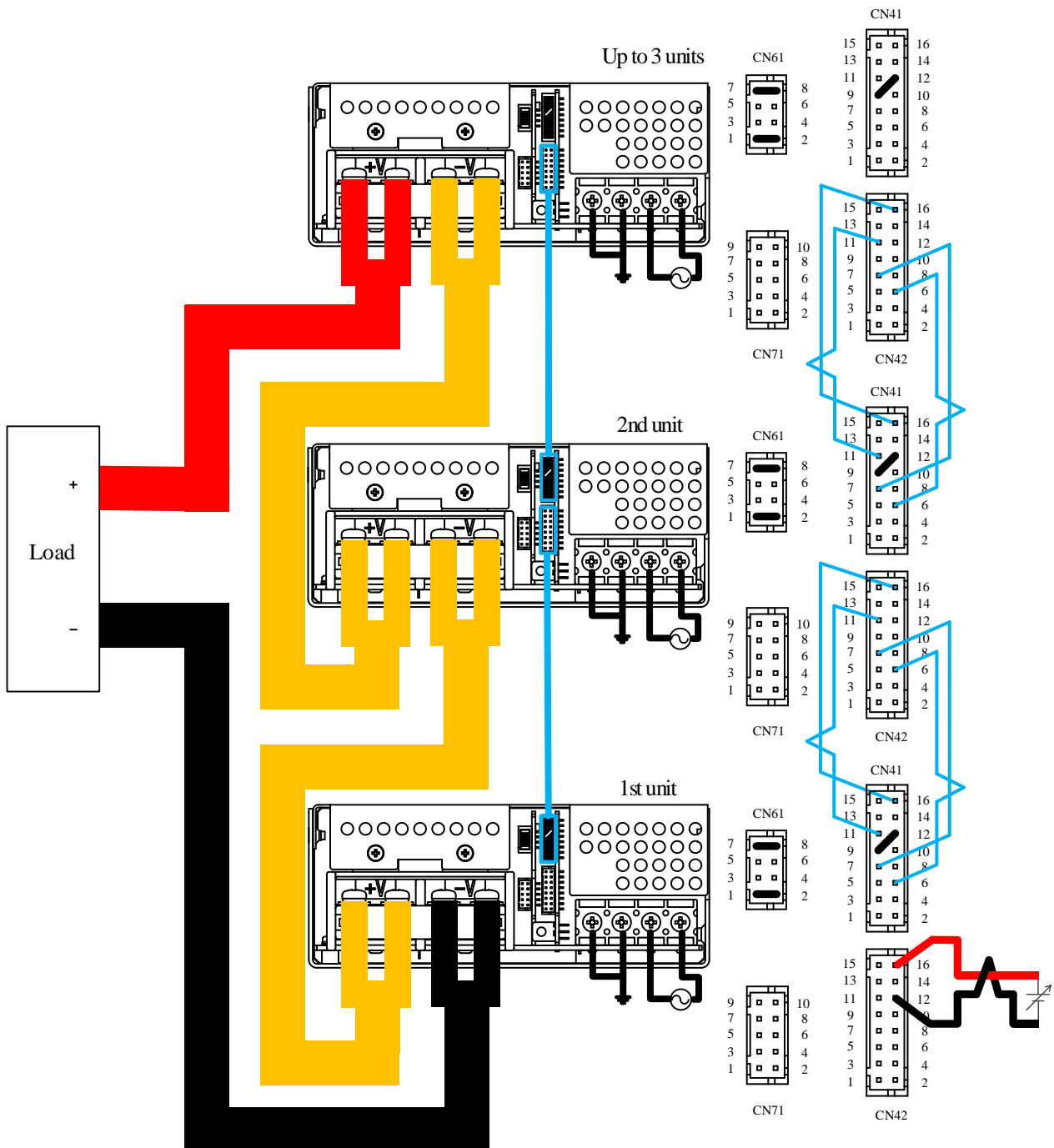

3-2-7. Output voltage monitor function

Measure the voltage between the VB terminal (pin No. 14 of CN41 or CN42) and the AG terminal (pin No. 11 or pin No. 12 of CN41 or CN42).

Use twisted or shielded signal wires.

Use a measuring device with an input impedance of 500kΩ or more.

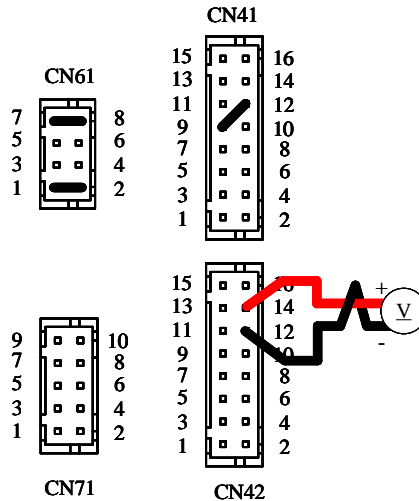

3-2-8. Output current monitor function

Measure the voltage between the CB terminal (pin No. 13 of CN41 or CN42) and the AG terminal (pin No. 11 or pin No. 12 of CN41 or CN42).

Use twisted or shielded signal wires.

Use a measuring device with an input impedance of 500kΩ or more.

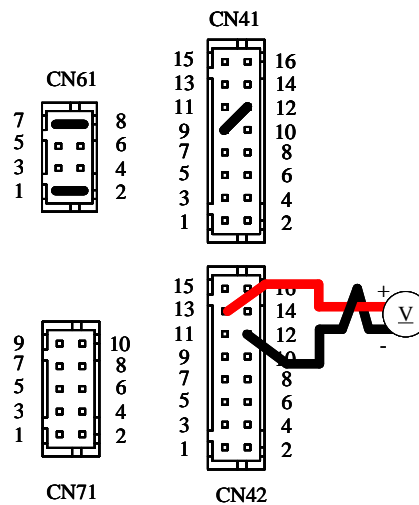

3-2-9. Constant voltage output mode voltage shortage alarm (VPF signal)

Open collector output. Connect the external voltage between the VPF terminal (pin No. 10 of CN71) and the DG terminal (pin No. 5 or pin No. 7 of CN71).

Use twisted or shielded signal wires.

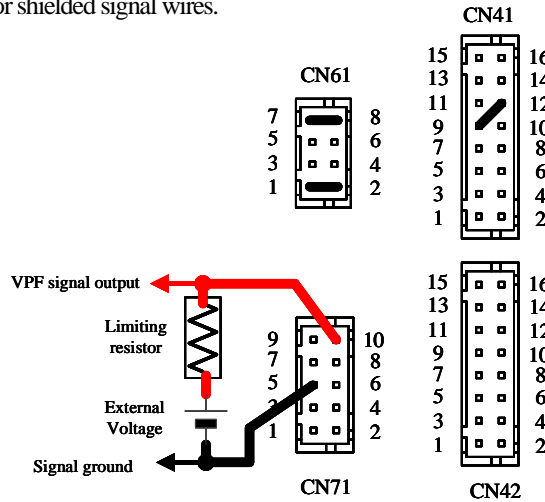

3-2-10. Constant current output mode current shortage alarm (CPF signal)

Open collector output. Connect the external voltage between the CPF terminal (pin No. 9 of CN71) and the DG terminal (pin No. 5 or pin No. 7 of CN71).

Use twisted or shielded signal wires.

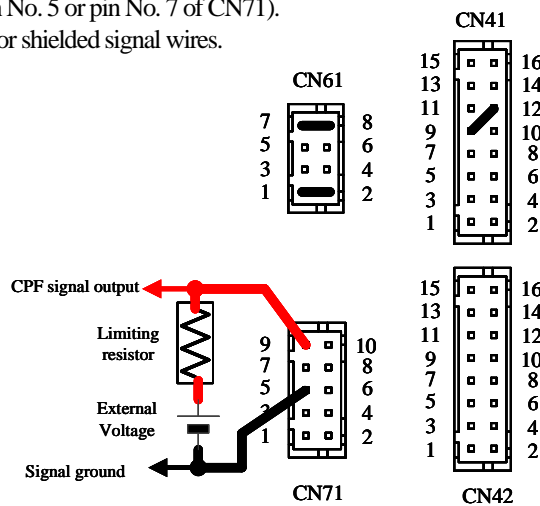

3-2-11. Input voltage shortage alarm (ACF signal)

Open collector output. Connect the external voltage between the ACF terminal (pin No. 8 of CN71) and the DG terminal (pin No. 5 or pin No. 7 of CN71).

Use twisted or shielded signal wires.

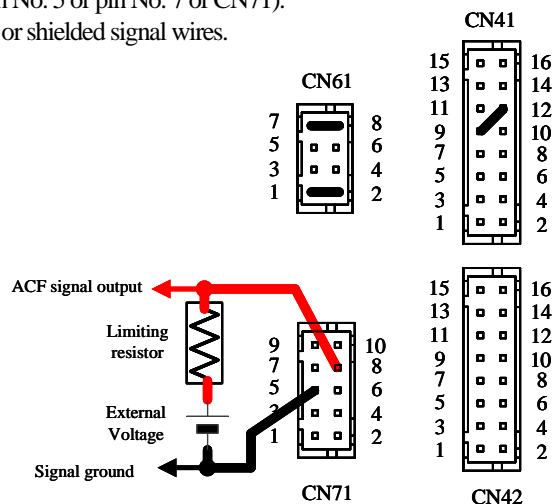

3-3. Connection method when using communication function

3-3-1. Connection method when using multiple power supplies in conjunction

Wiring starts from the power supply that connects to the host device.

Connect between the RS-485 + terminal of the host device and the +D terminal (CN41 or CN42 pin No. 2) of the power supply to be connected. Connect between the RS-485 - terminal of the host device and the -D terminal (pin No. 1 of CN41 or CN42) of the power supply to be connected. Connect between the RS-485 signal ground (SG) terminal of the host device and the DG terminal (pin No. 4 or pin No. 6 of CN41 or CN42) of the power supply to be connected.

Starting from the power supply connected to the host device, connect "+D terminals, -D terminals, and DG terminals" of all power supplies. Make a short connection between the +D terminal and -DR terminal (CN41 or CN42 pin No. 3) of the last power supply. Connect the A/O terminal (pin No. 5 of CN42) of the starting power supply to the A/I terminal (pin No. 5 of CN41) of the second power supply. Connect the A/O terminal (pin No. 5 of CN42) of the second power supply to the A/I terminal (pin No. 5 of CN41) of the n-th power supply (last power supply).

Connect the terminating resistor to the RS-485 port of the host device. The host device may have a built-in termination resistor. Please refer to the instruction manual of the host device.

Connect the CB and VB terminals as necessary.

Use twisted or shielded signal wires.

Note: Be sure to use twisted pair wires with characteristic impedance of 100 Ω for the +D and -D terminals, which are compatible with RS-485. See section 2-1-1 for details.

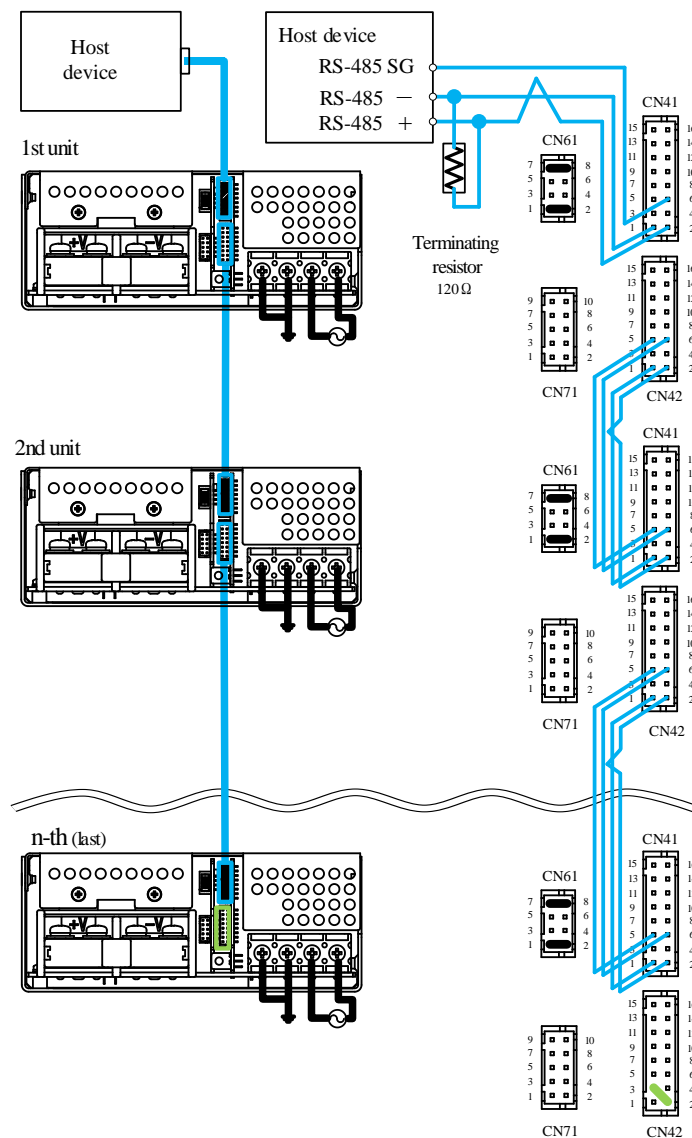

[TOP](#)

3-3-2. Case for use with one power supply

Connect between the RS-485 + terminal of the host device and the +D terminal (CN41 or CN42 pin No. 2) of the power supply. Connect between the RS-485 - terminal of the host device and the -D terminal (CN41 or CN42 pin No. 1) of the power supply. Connect the RS-485 signal ground Terminal (SG) of the host device and the DG terminal (pin No. 4 or pin No. 6 of CN41 or CN42) of the power supply .

Connect between the +D terminal and -DR terminal (CN41 or CN42 pin No. 3) of the power supply.

Connect the terminating resistor to the RS-485 port of the host device. The host device may have a built-in termination resistor. Please refer to the instruction manual of the host device.

Note: Be sure to use twisted pair wires with characteristic impedance of 100 Ω for the +D and -D terminals, which are compatible with RS-485. See section 2-1-1 for details.

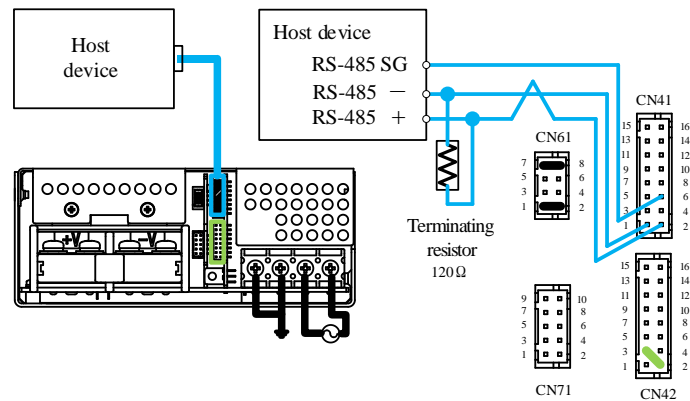

3-3-3. Cases for changing power output settings and checking operation history

Make the connections below. Setting changes and operation history can be checked without applying input voltage to the power supply. Refer to the Communication Manual for details.

Connect an external voltage between the PWR terminal (pin No. 8 of CN41 or CN42) and the AG terminal (pin No. 11 or pin No. 12 of CN41 or CN42).

Connect between the RS-485 + terminal of the host device and the +D terminal (pin No. 2 of CN41 or CN42) of the power supply. Connect between the RS-485 - terminal of the host device and the -D terminal (CN41 or CN42 pin No. 1) of the power supply. Connect the RS-485 signal ground terminal (SG) of the host device and the DG terminal (pin No. 4 or pin No. 6 of CN41 or CN42) of the power supply.

Connect between the +D terminal and -DR terminal (pin No. 3 of CN41 or CN42) of the power supply.

Connect the terminating resistor to the RS-485 port of the host device. The host device may have a built-in termination resistor. Please refer to the instruction manual of the host device.

Use twisted or shielded signal wires.

Note: Be sure to use twisted pair wires with characteristic impedance of 100 Ω for the +D and -D terminals, which are compatible with RS-485. See section 2-1-1 for details.

• Be sure to disconnect the PWR terminal when using the product with input voltage applied.

If an external voltage is applied to the PWR terminal while input voltage is being applied, the protection function will activate and cut off the output.

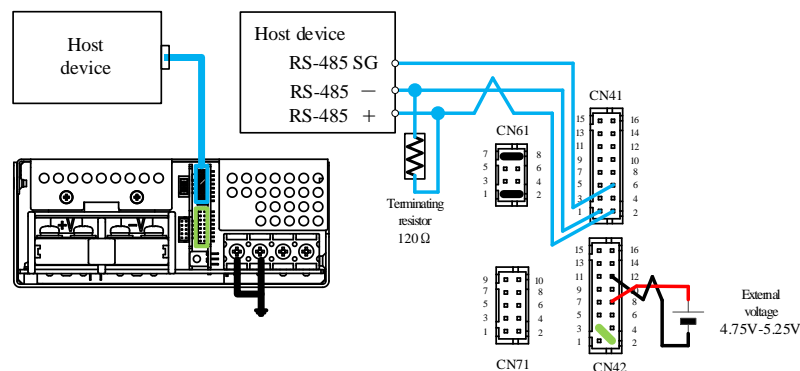

4. Notes on wiring

[TOP](#)

4-1. Input/output wiring

- (1) The output load line and input line shall be separated, and use all lines as thick and short as possible to make lower impedance. The output load line and input line shall be twisted or use shielded wire to improve noise sensitivity.

The recommended wire type, torque and crimp-type terminal :

	Recommended Wire	Recommended torque	Recommended crimp-type terminal		
			D (MAX)	t (MAX)	Mounting pieces (MAX)
Input terminal	AWG12-22	M4 Screws 1.2N·m (12.2kgf·cm) ~ 1.6N·m (16.3kgf·cm)	9.1mm	1.0mm	1piece
				0.8mm	2pieces
Output terminal	AWG6-14	M5 Screws 2.0N·m (20.4kgf·cm) ~ 2.4N·m (24.4kgf·cm)	12.0mm	1.5mm	1piece

Note : Recommended wire type and crimp-type terminal vary depending on use conditions. Choice most appropriate wire type and crimp-type terminal after referring to wire maker recommended allowable current and voltage drop.

Thick diameter wire is recommended.

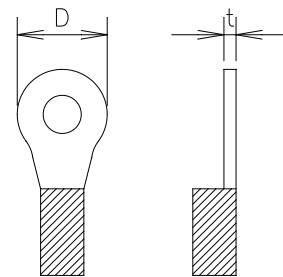

- (2) Noise can be reduced by attaching a capacitor to the load terminals.
 (3) The output terminal can be wired on the top or front side.

For safety, we recommend installing the attached terminal cover on the side that will not be used.
 At the time of shipment, the mounting screws are attached to the top surface.

It cannot be installed on two sides at the same time as there is a risk that the screws may come into contact with each other internally.

Output terminal top side screw (Shipment condition)

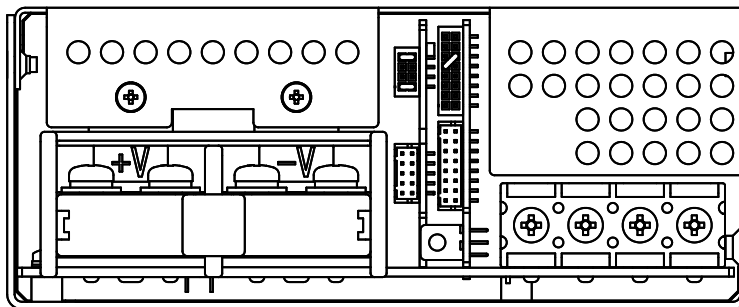

Output terminal front side screw

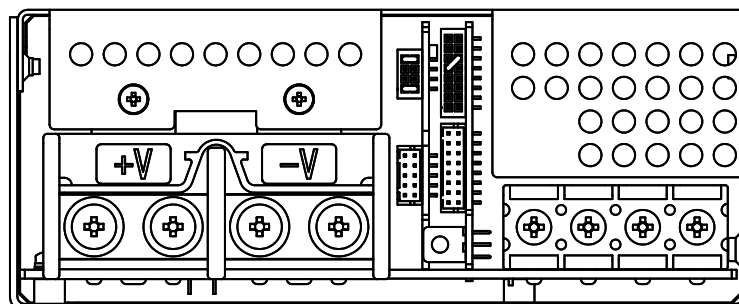

[TOP](#)

4-2. Signal wiring

- (1) Be sure to twist the signal wire and separate it from the input and output wires.
- (2) Hold the socket housing firmly and insert it straight into the post until it clicks into place.
- (3) To pull out the connector, hold the wires together, secure the socket housing with your fingers so as not to pry it, and pull it out while mating.

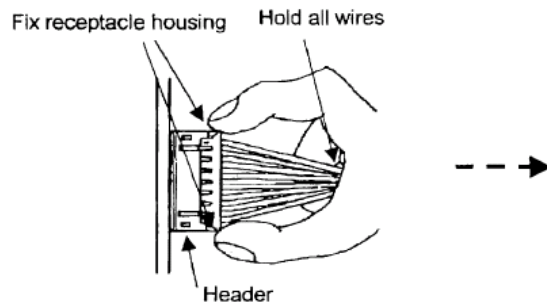

5. Installation method and notes

[TOP](#)

- (1) Forced air cooling power supply with built-in fan. There are cooling air intake and exhaust ports on the front and rear sides. Leave a space of at least 50mm from the intake and exhaust surfaces.
 In addition, in a dusty environment, if ventilation becomes poor due to clogged intake/exhaust ports, or if conductive foreign matter, dust, or liquid enters the power supply, there is a risk of failure or malfunction.
- (2) The maximum allowable penetration of mounting screws is 6mm.
 Incomplete threads must not enter inside the power supply.
- (3) Recommended torque for mounting screw.
 M4 screw : 1.27 N·m (13.0kgf·cm)
- (4) The power supply is considered a component which will be installed into a final equipment.
 Depending on the environment in which the power supply is installed, it may not meet EMC, vibration resistance, and shock resistance specifications.
 The final equipment should be re-evaluated that it meets EMC, vibration and shock requirement.

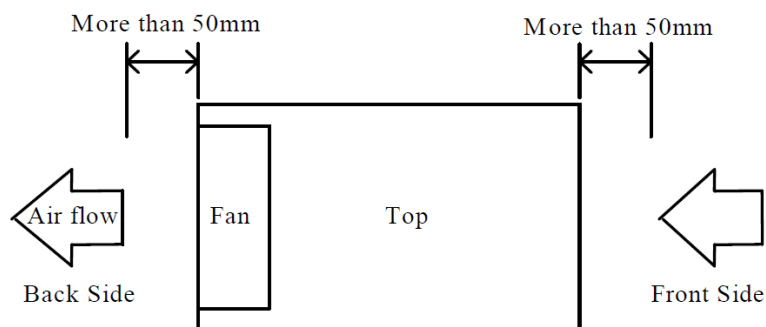

5-1. Mounting direction

The mounting direction is shown in the figure below. The standard mounting direction is (A).
 For output derating, refer to specifications (A291-01-02_).

- Mounting direction (A) is the only mounting direction that satisfies the vibration and shock resistance listed in the specifications.
- The power supply is considered a component which will be installed into a final equipment.
 Depending on the environment in which the power supply is installed, it may not meet EMC, vibration resistance, and shock resistance specifications.
 The final equipment should be re-evaluated that it meets EMC, vibration and shock requirement.

■ Mounting direction A
 Standard mounting

■ Mounting direction B

■ In case of strong vibration or shock
 Fix the bottom and sides together.

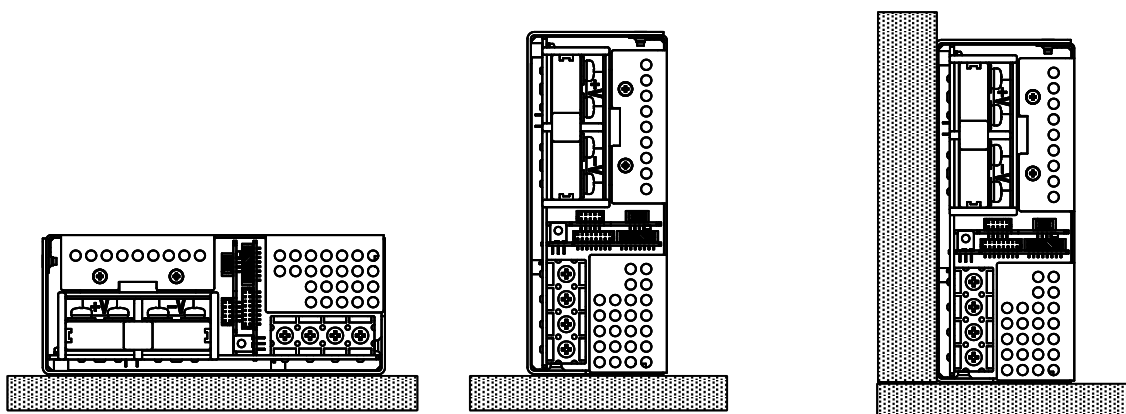

6. Functional explanation and notes

[TOP](#)

6-1. Input voltage

Input voltage range is single-phase 85 - 265VAC (47 - 63Hz).

The maximum power is different for the input voltage range 85 - 132VAC (47 - 63Hz) and 170 - 265VAC (47 - 63Hz), and the protection function threshold switches depending on the input voltage. When switching the input voltage from the 100V line to the 200V line, or from the 200V line to the 100V line, first cut off the input and wait 60 seconds before switching.

Applying input voltage outside of specifications may damage the power supply.

The safety standard certified input voltage range is 100 - 120VAC/200 - 240VAC (50 - 60Hz).

6-2. Input inrush current

The switch method is used for limiting the inrush current. Higher current might flow when input turn on interval is short.

First inrush current and second inrush current flow. Select input switch and external fuse carefully.

6-3. Variable output voltage (variable constant voltage output setting value)

In the initial state, the output voltage of the power supply is set to the nominal output voltage value.

The output voltage can be set using the built-in output voltage adjustment trimmer or external signals (communication function, CV terminal external voltage application, CV terminal external current application).

When using the product at a voltage exceeding the rated voltage, it is necessary to derate the output current so as not to exceed the maximum output power.

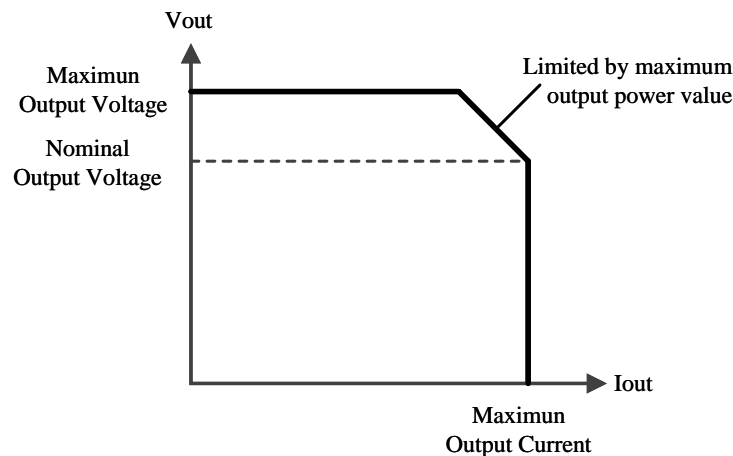

6-3-1. Variable with built-in output voltage adjustment trimmer

The built-in output voltage adjustment trimmer allows you to change the constant voltage output value setting.

Turning the output voltage adjustment trimmer clockwise, the output voltage will be increased.

For the output voltage variable range refer to specifications (A291-01-01_).

6-3-2. Variable by external power (CV terminal external voltage applied)

The constant voltage output value setting can be changed by applying an external voltage in the range of 1-5.4V or 1-5.8V between the CV and AG terminals.

When an external voltage is applied to the CV terminal, the output voltage adjustment trimmer setting value will be invalid.

Note that if no external voltage is applied to the CV terminal when the input is turned on, the output voltage will be the setting value of the output voltage adjustment trimmer.

Internal resistance between CV terminal and AG terminal is 250Ω. Pay attention to the current limit of the external voltage source.

◆ 24V, 130V

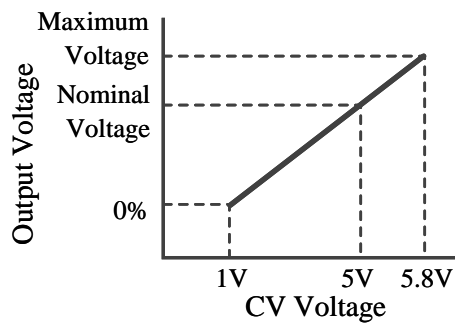

◆ 48V, 60V

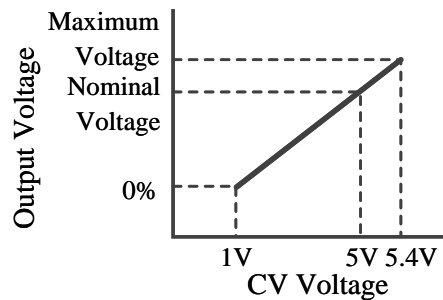

■ Internal resistance between CV terminal and AG terminal

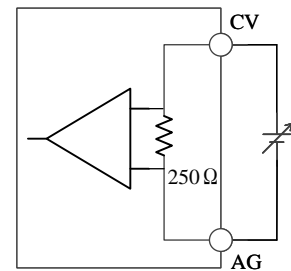

6-3-3. Variable by external power (CV terminal external current applied)

The constant voltage output value setting can be changed by applying an external current in the range of 4-21.6mA or 4-23.2mA to the CV terminal.

Connect the external power supply ground to the AG terminal.

When an external current is applied to the CV terminal, the output voltage adjustment trimmer setting value will be invalid.

Note that if no external current is applied to the CV terminal when the input is turned on, the output voltage will be the setting value of the output voltage adjustment trimmer.

When using multiple power supplies, daisy chain connection of CV terminals is not possible. When connecting in a daisy chain, apply external voltage to the CV terminal (Section 6-3-2).

◆ 24V, 130V

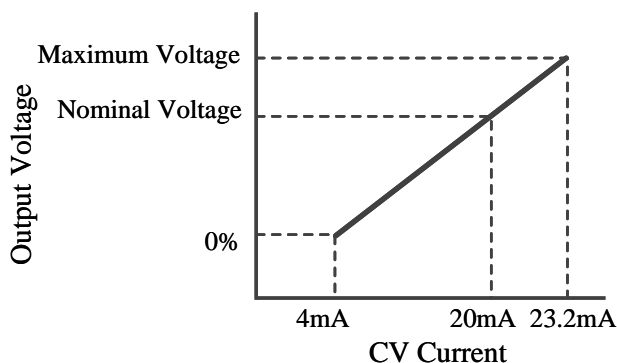

◆ 48V, 60V

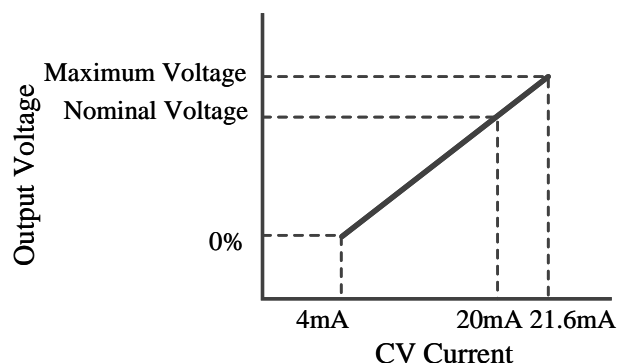

6-3-4. Variable by communication

Constant voltage output value settings can be changed using Modbus RTU.

When communication is enabled, the output voltage adjustment trimmer and the set value by external application to the CV terminal will be invalidated.

When communication is enabled, the output voltage setting value is maintained even if the input voltage is cut off.

Refer to communication manual (A291-04-02_).

6-4. Variable output current (variable constant current output setting value)

Output current can be set using an external signal (communication function, CC terminal external voltage application, CC terminal external current application).

In constant current operation, when the output voltage reaches the value set by the built-in volume or external signal (communication function, CV terminal external voltage application, CV terminal external current application), it switches to constant voltage operation.

When using the product at a voltage exceeding the rated voltage, it is necessary to derate the output current so as not to exceed the maximum output power.

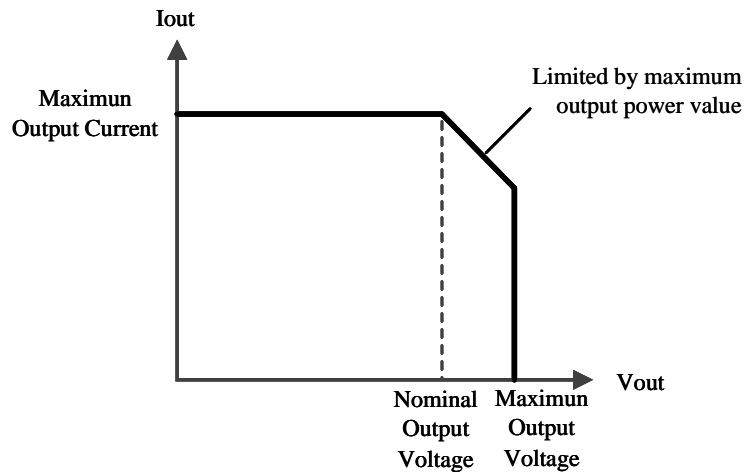

6-4-1. Variable by external power (CC terminal external voltage applied)

The constant current output value setting can be changed by applying an external voltage in the range of 1-5V between the CC and AG terminals.

Note that if no external voltage is applied to the CC terminal when the input is turned on, the power output will be a constant voltage output.

Internal resistance between CC terminal and AG terminal is 250Ω . Pay attention to the current limit of the external voltage source.

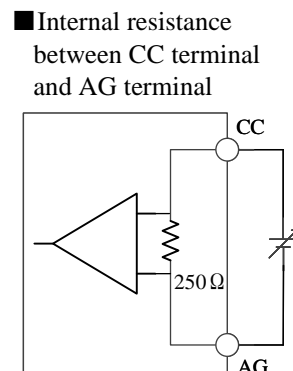
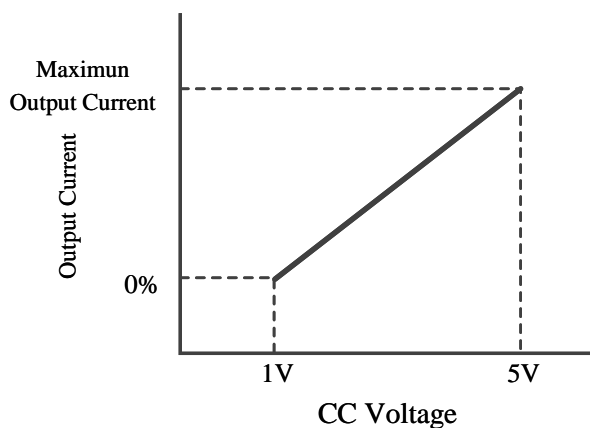

6-4-2. Variable by external power (CC terminal external current applied)

The constant current output value setting can be changed by applying an external current in the range of 4-20mA to the CC terminal.

Connect the external power supply ground to the AG terminal.

Note that if no external current is applied to the CC terminal when the input is turned on, the power output will be a constant voltage output.

When using multiple power supplies, daisy chain connection of CC terminals is not possible.

When connecting in a daisy chain, apply external voltage to the CC terminal (Section 6-4-1).

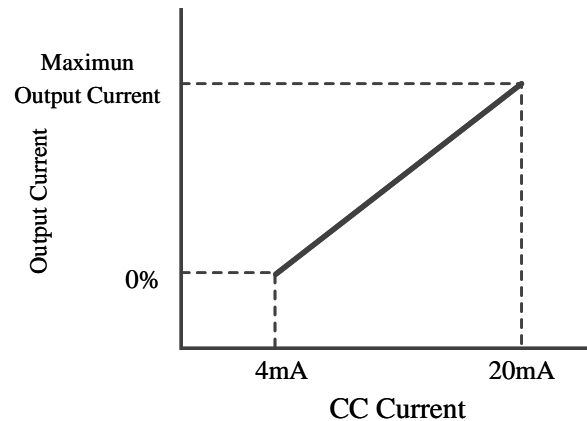

6-4-3. Variable by communication

Constant current output value settings can be changed using Modbus RTU.

When communication is enabled, the set value by external application to the CC terminal will be invalidated.

When communication is enabled, the output current setting value is maintained even if the input voltage is cut off.

Refer to communication manual (A291-04-02_).

6-5. Over voltage protection (OVP)

OVP function is output shutdown method and manual reset type.

When OVP is activated, shut off the input, correct the cause of the overvoltage, and then turn it back on after a few minutes.

Or, turn off the remote ON/OFF control signal, correct the cause of the overvoltage, and then turn it back on.

Never apply voltage externally to the output terminal to avoid unit failure.

In case of inductive load, put protective diode in series to the output power line.

6-6. Over current protection (OCP)

Constant current limit with automatic recovery.

If the overcurrent protection operation continues for 30 seconds or more, the output will latch and stop.

In addition, the output will latch and stop if a sudden output short circuit occurs.

When the latch stops, shut off the input, correct the cause of the overcurrent, and then turn it back on after a few minutes.

Or, turn off the remote ON/OFF control signal, correct the cause of the overcurrent, and then turn it back on.

Never operate the unit under over current or shorted conditions, which may lead unit damage.

6-7. Output ripple & noise

The maximum ripple noise voltage value in the specifications is the value measured using the measurement circuit below.

When load lines are longer, ripple will become larger. In this case, electrolytic capacitor, film capacitor, etc. might be necessary to use across the load terminal.

The output ripple cannot be measured accurately if the probe ground lead of oscilloscope is too long.

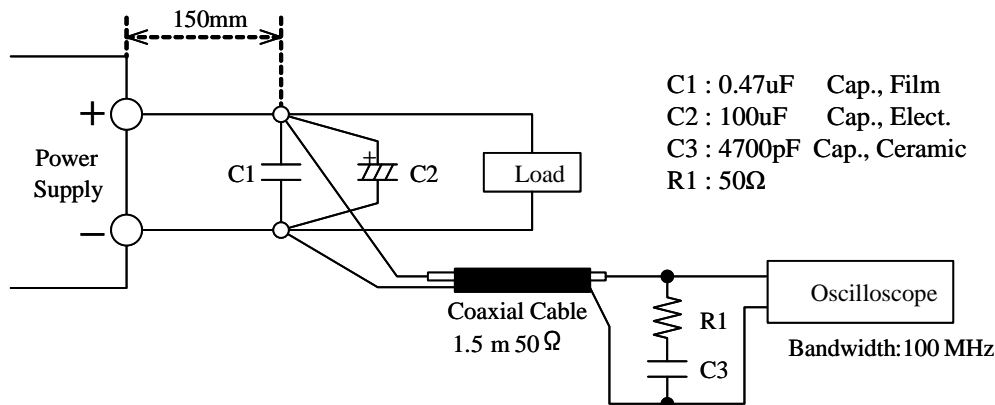

6-8. Remote sensing (+S, -S terminal)

This function compensates voltage drop of wiring from output terminals to load terminals.

Connect "+S" terminal to "+" terminal of load and "-S" terminal to "-" terminal of load with sensing wires.

The total line voltage drop (+ side line and - side line) shall be less than 0.3V.

In case that sensing line is too long, we recommend connecting electrolytic capacitors at the following locations:

- 1) Across the load terminals,
- 2) Between "+S" terminal and "+L" terminal,
- 3) Between "-S" terminal and "-L" terminal.

When not using the remote sensing function, short-connect the "+S" and "+L" terminal, and the "-S" and "-L" terminal.

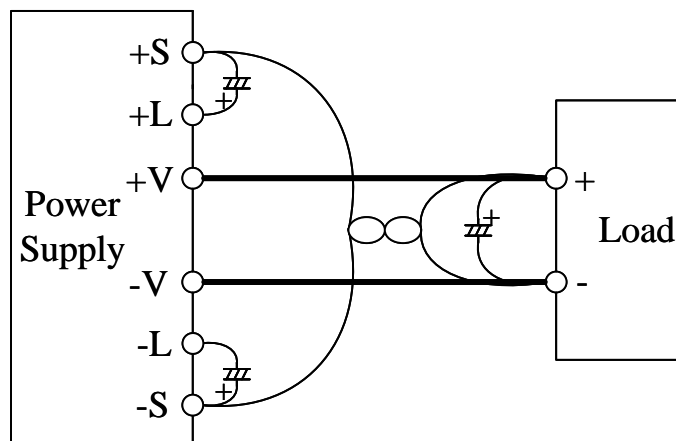

6-9. Parallel operation

Four types of parallel connection are possible: parallel operation to increase output current, N+1 redundant operation, connection as a backup power source (1+1 redundant operation), and leader-follower.

When using series-parallel connections, connect series-connected units in parallel.

6-9-1. Parallel operation to increase output current

(A) When using in constant voltage output mode

Connecting CB to CB terminal and AG to AG terminal, the current balancing function activates and output current of each power supply is equivalently supplied to load.

The CB and AG terminals are isolated from the power input and output circuits.

Wire to CB terminal, AG terminals shall be as short as possible and same length with twist.

(B) When using in constant current output mode

Connect the CC and AG terminals between the power supplies, and apply an external voltage between the CC and AG terminals.

The CC and AG terminals are isolated from the power input and output circuits.

Wire to CC terminal, AG terminals shall be as short as possible and same length with twist.

- Adjust the output voltage of each power supply to be same value within 1%.
- Use same length and type of wires for all load lines.
- Parallel operation is possible up to 10 units. Maximum value of output current in parallel is up to 95% of all paralleled models.
- There is a possibility that output voltage dips at dynamic load change.
- When changing the output rise speed settings (both current and voltage) using the communication function, be sure to use the same settings for all power supplies.

(A) When using in constant voltage output mode

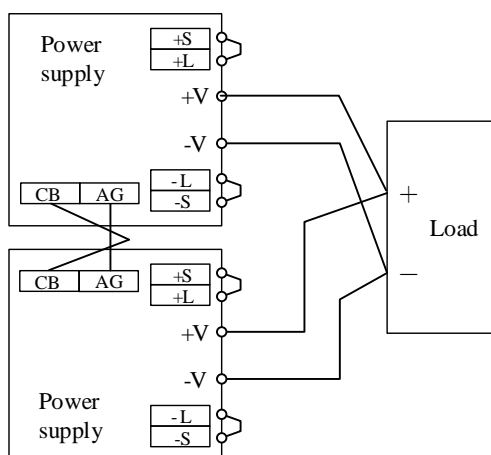

(B) When using in constant current output mode

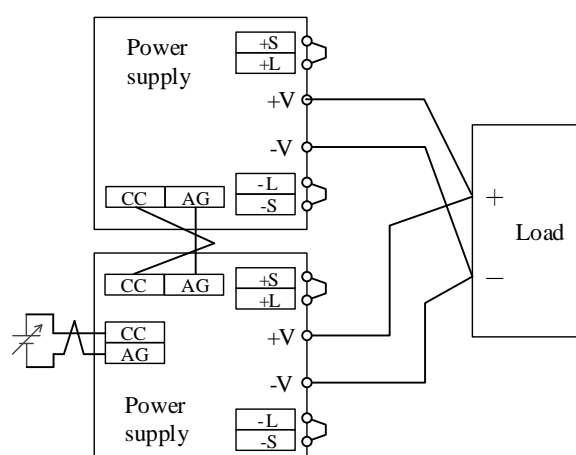

6-9-2. N+1 redundant operation

In power supply systems that require higher reliability, it is possible to increase system reliability by using N+1 units for a load of N units.

When N+1 units are operating in parallel, even if one unit stops, the load current is automatically shared with the other power supplies to maintain system functionality.

Connecting CB to CB terminal and AG to AG terminal, the current balancing function activates and output current of each power supply is equivalently supplied to load.

This product has a function to disconnect the CB terminal when the power is stopped, which suppresses fluctuations in the output voltage when one unit is stopped.

The CB and AG terminals are isolated from the power input and output circuits.

- Wire to CB terminal, AG terminals shall be as short as possible and same length with twist.
- Adjust the output voltage of each power supply to be same value within 1%.
- Use same length and type of wires for all load lines.
- Parallel operation is possible up to 10 units. Maximum value of output current in parallel is up to 95% of all paralleled models.
- There is a possibility that output voltage dips at dynamic load change.
- When changing the output rise speed settings (both current and voltage) using the communication function, be sure to use the same settings for all power supplies.
- Even if one unit stops, check that the output current satisfies the formula below using only a normally operating power supply.

$$\text{Maximum output current} \leq \text{Rated current per power supply} \times \text{Number of power supplies operating normally} \times 0.95$$

- Redundant operation is not possible with other products.
- When two or more power supplies fail and cannot supply output current, the output voltage may drop and the system may stop. If even one power supply is found to be faulty, immediately replace the faulty power supply.

A failed power supply can be identified using the shortage alarm.

- Disconnect the input voltage before removing or replacing a failed power supply.
- Depending on the failure mode of the power supply, redundant operation may not be possible. If you want to perform complete redundant operation, please build a redundant function by adding a diode to the output of the power supply.

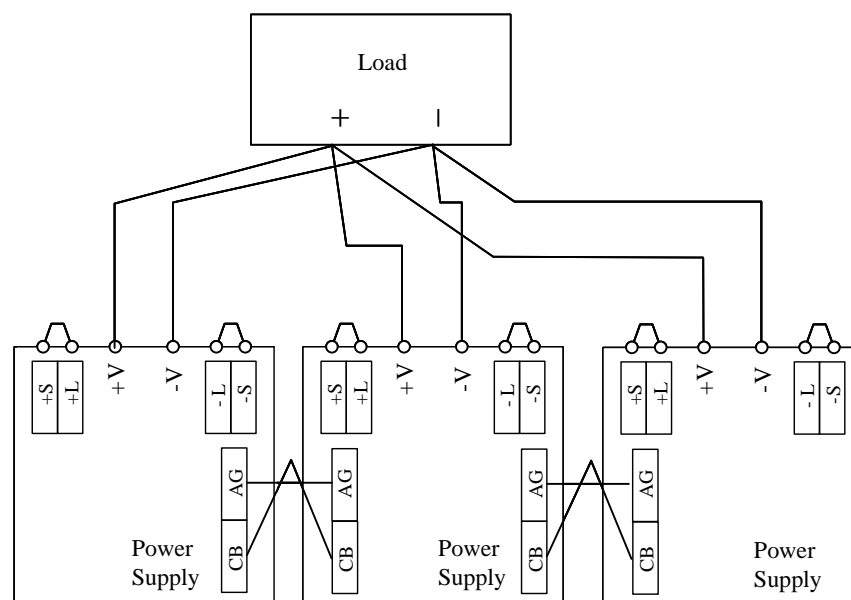

6-9-3. Backup power source (1+1 redundant operation)

- Adjust the output voltage higher by the value of forward voltage drop (VF) of the diode.
- *Output voltage and output power should be used within specifications.
- Use blocking diode to prevent reverse current. Diode current rating must be more than output load current.

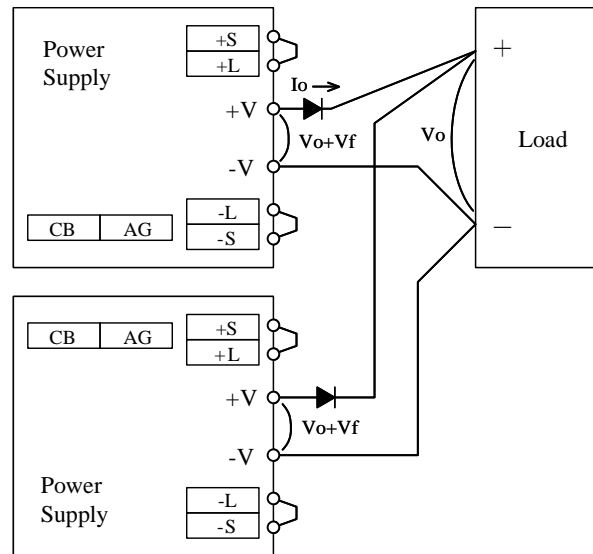

6-9-4. Leader-Follower connection

Leader-Follower control allows multiple power supplies to be linked together with one control. The controlling side is called the "leader machine" and the controlled side is called the "follower machine."

Set each power supply to the leader machine and follower machine, and connect the leader/follower. Then, use the method of "parallel operation to increase output current" described in 6-9-1.

When connecting a Leader-Follower, it cannot be used in N+1 redundant operation. If the leader machine stops or malfunctions, the entire system will stop.

For details on setting the leader machine and follower machine, and how to connect the leader-follower, see section 3-2-1.

◆ Leader-Follower control list

<Analog function>

The following controls are possible by applying analog signals to the leader machine after connecting the leader-follower.

- Remote ON/OFF control
- Output voltage variable by built-in volume or external signal (CV terminal external voltage applied, CV terminal external current applied)
- Output current variable by external signal (CC terminal external voltage applied, CC terminal external current applied)

<Pre-configuration>

If you set the following functions to the leader machine via communication in advance, the follower machines will have the same settings.

*When a leader-follower is connected, settings cannot be changed via communication.

When configuring settings via communication, please configure the settings on the leader machine before connecting the leader/follower.

- Constant voltage output setting value using built-in volume or communication function
- Constant current output setting value using communication function
- Setting of output rise speed (both current and voltage) using communication function

6-10. Series operation

Three types of series connection are possible: series operation for increasing output voltage, series operation for plus/minus output, and leader-follower.

When using series-parallel connections, connect series-connected units in parallel.

6-10-1. Series operation for increasing output voltage

As a protection when one of the series-connected units stops, connect the HL to HL terminals and DG to DG terminals between the power supplies that are operated in series. If even one power supply stops (stops or breaks down), all remaining power supplies will be stopped.

(A) When using in constant current output mode

Connecting VB to VB terminal and AG to AG terminal, the voltage balancing function activates and it is possible to operate in constant current output mode even during series operation.

Adjust the output voltage of each power supply to be same value within 1%.

The VB and AG terminals are isolated from the power input and output circuits.

Wire to VB terminal, AG terminal, HL terminal, DG terminal shall be as short as possible and same length with twist.

(B) When using in constant voltage output mode

Connect the CV and AG terminals between the power supplies, and apply an external voltage between the CV and AG terminals.

The CV and AG terminals are isolated from the power input and output circuits.

Wire to CV terminal, AG terminal, HL terminal, DG terminal shall be as short as possible and same length with twist.

When changing the constant voltage output value using the built-in output voltage adjustment trimmer : Connection between CV and AG terminals is not required. When using the product at a voltage exceeding the rated voltage, be careful not to exceed the maximum output power.

- Series operation is possible up to 3 units.
- When changing the output rise speed settings (both current and voltage) using the communication function, be sure to use the same settings for all power supplies.

(A) When using in constant current output mode

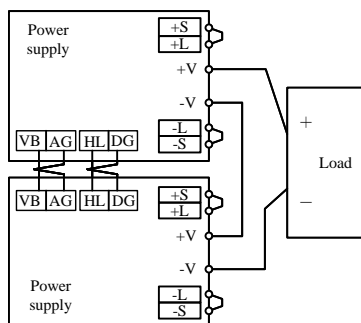

(B) When using in constant voltage output mode

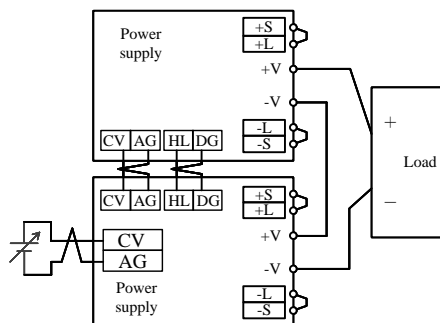

(B) When using in constant voltage output mode
 (Using output voltage adjustment trimmer)

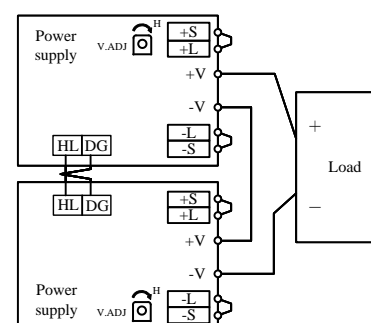

6-10-2. Series operation for plus/minus output

Series operation is possible for plus/minus output.

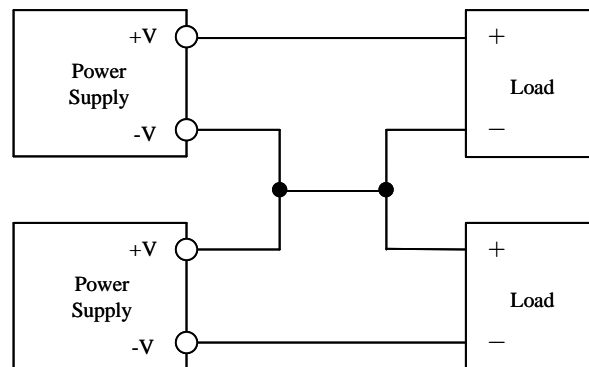

6-10-3. Leader-Follower connection

Leader-Follower control allows multiple power supplies to be linked together with one control.

The controlling side is called the "leader machine" and the controlled side is called the "follower machine."

Set each power supply to the leader machine and follower machine, and connect the leader/follower.

Then, use the method of "series operation to increase output voltage" described in 6-10-1.

For details on setting the leader machine and follower machine, and how to connect the leader-follower, see section 3-2-1.

◆ Leader-Follower control list

<Analog function>

The following controls are possible by applying analog signals to the leader machine after connecting the leader-follower.

- Remote ON/OFF control
- Output voltage variable by built-in volume or external signal (CV terminal external voltage applied, CV terminal external current applied)
- Output current variable by external signal (CC terminal external voltage applied, CC terminal external current applied)

<Pre-configuration>

If you set the following functions to the leader machine via communication in advance, the follower machines will have the same settings.

*When a leader-follower is connected, settings cannot be changed via communication.

When configuring settings via communication, please configure the settings on the leader machine before connecting the leader/follower.

- Constant voltage output setting value using built-in volume or communication function
- Constant current output setting value using communication function
- Setting of output rise speed (both current and voltage) using communication function

6-11. Redundant operation disable function

When linking multiple power supplies, it is possible to disable redundant operation so that all units stop when one unit stops.

Connect the HL to HL terminals and DG to DG terminals between the power supplies.
If even one power supply stops (stops or breaks down), all remaining power supplies will be stopped.

It can also be used for stop protection during series or parallel operation, or when you want to synchronize the start and stop timing of power supplies.

- Wire to HL terminal, DG terminals shall be as short as possible and same length with twist.
- Redundant operation disable function is possible up to 30 units.

6-12. AUX output

The AUX output voltage is 5V Typ. (4.8 to 5.2V), and the maximum output current is 2A.

The AUX output does not depend on the state of the main output.

AUX output is output even when the main output is in the control OFF state.

Even if the main output is stopped due to a protection function, the AUX will continue to output.

Over Current Protection (OCP) is fold back limit and hiccup mode with automatic recovery.

OCP function operates when the output current exceeds 105% of maximum DC output current of specification.

The outputs will be automatically recovered when the overload condition is canceled.

Never operate the unit under over current or shorted conditions, which may leads damage or insulation failure.

Never apply higher voltage externally to the output terminal to avoid unit failure.

In case of inductive load, put protective diode in series to the output power line.

6-13. Remote ON/OFF control

Output ON/OFF can be controlled while maintaining the input application state.

Remote ON/OFF control can be controlled in four ways: output by applying external voltage, output by shorting between terminals, output by opening between terminals, and ON/OFF control by communication function.

If you do not use this function, short the -R terminal and AG terminal.

1) Output by applying external voltage

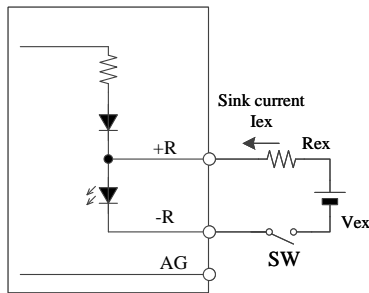

+R to -R terminal voltage	Output status
4.5V or more	ON
0.5V or less	OFF

Requires a limit on sink current I_{ex} .

Select V_{ex} and R_{ex} so that I_{ex} is in the range of 2 to 5mA using the formula below.

V_{ex} is 4.5V or more and 25.5V or less.

$$I_{ex} = (V_{ex} - 1.1) / (R_{ex})$$

2) Output by shorting between terminals

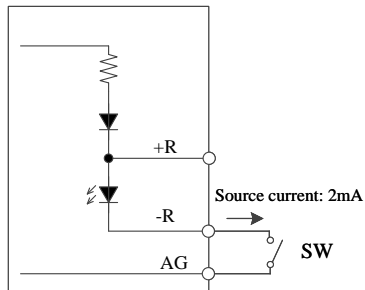

SW	Output status
ON	ON
OFF	OFF

3) Output by opening between terminals

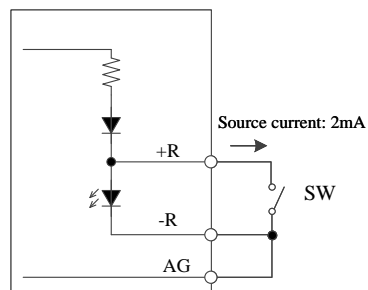

SW	Output status
OFF	ON
ON	OFF

6-14. Output voltage monitor function

The output voltage can be monitored by measuring the voltage between the VB and AG terminals.

- Use a measuring device with an input impedance of 500k Ω or more
- Do not short-circuit between the VB terminal and AG terminal. It will be the cause of the failure.
- VB terminal voltage may be 1V or less when remote control is off or output is stopped by protection function.

The relationship between VB terminal voltage and output voltage is as follows.

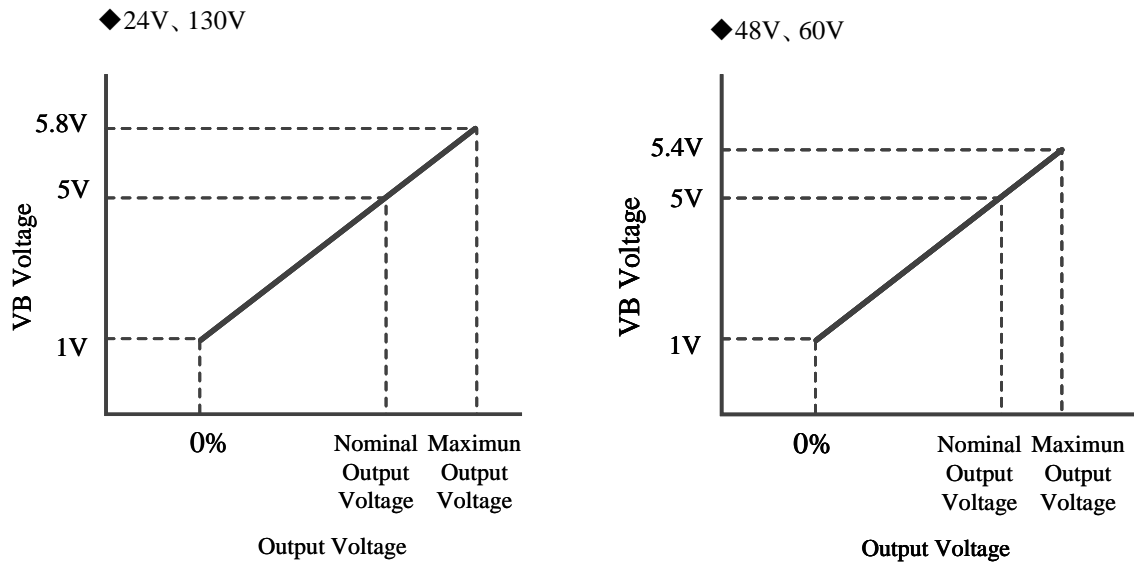

6-15. Output current monitor function

The output current can be monitored by measuring the voltage between the CB and AG terminals.

- Use a measuring device with an input impedance of 500k Ω or more
- Do not short-circuit between the CB terminal and AG terminal. It will be the cause of the failure.
- CB terminal voltage may be 1V or less when remote control is off or output is stopped by protection function.

The relationship between CB terminal voltage and output current is as follows.

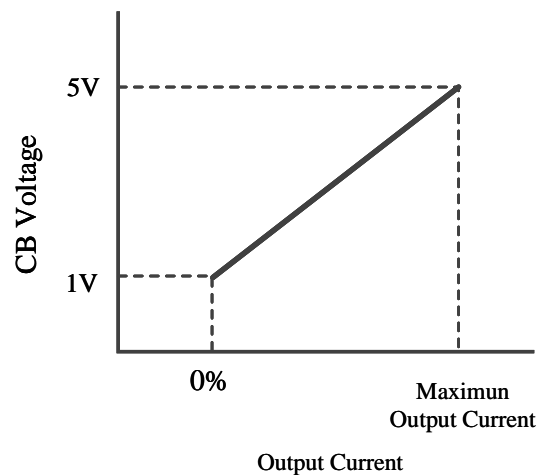

6-16. Constant voltage output mode voltage shortage alarm (VPF signal)

Detects converter oscillation stop. At this time, the VPF signal goes high.

Conditions for converter oscillation to stop: When the input voltage drops, during a momentary power outage, when an abnormality occurs that activates various protection functions, when the remote control is turned off, or when the voltage on the load side is higher than the power supply output setting voltage. The VPF signal is an open collector output, and the emitter is connected to the DG terminal.

Note: VPF signal may also be output in the following cases

- When the output is light load in parallel operation or N+1 redundant operation
- When the output voltage drops to 10% or less of the nominal voltage
- When the output voltage is suddenly reduced by using the variable output voltage function under light load conditions.
- When the output voltage is lowered to 10% or less of the rated voltage using the output voltage variable function
- When the rotation speed of the FAN becomes abnormal or when it stops

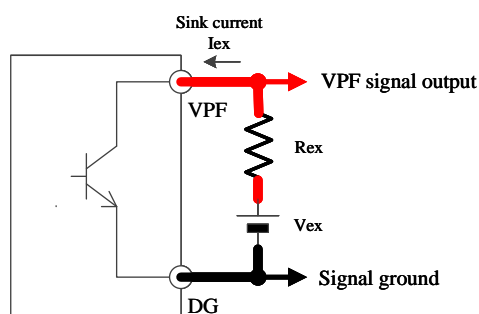

Requires a limit on sink current I_{ex} .

Select V_{ex} and R_{ex} so that I_{ex} is within the range of 0.1 to 20mA using the formula below.

V_{ex} is 1V or more and 30V or less.

$$I_{ex} = (V_{ex} - 0.3) / (R_{ex})$$

6-17. Constant current output mode current shortage alarm (CPF signal)

Detects converter oscillation stop. At this time, the CPF signal goes high.

Conditions for converter oscillation to stop: When the input voltage drops, during a momentary power outage, when an abnormality occurs that activates various protection functions, when the remote control is turned off, or when the voltage on the load side is higher than the power supply output setting voltage. The CPF signal is an open collector output, and the emitter is connected to the DG terminal.

Note: CPF signal may also be output in the following cases

- When the output is light load in parallel operation or N+1 redundant operation
- When the output current is suddenly reduced using the variable output current function
- When using the variable output current function to reduce the output current to 10% or less of the maximum current
- When the rotation speed of the FAN becomes abnormal or when it stops

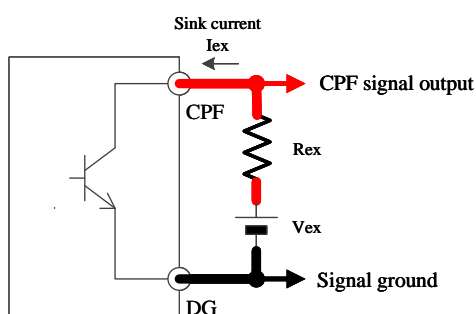

Requires a limit on sink current I_{ex} .

Select V_{ex} and R_{ex} so that I_{ex} is within the range of 0.1 to 20mA using the formula below.

V_{ex} is 1V or more and 30V or less.

$$I_{ex} = (V_{ex} - 0.3) / (R_{ex})$$

6-18. Input voltage shortage alarm (ACF signal)

It detects that the input voltage is cut off and the ACF signal becomes High.

When the power supply output power is 20% or more, the time from the input cutoff state until the signal becomes High is 15ms or less.

This time may change if the power supply output power is less than 20% of maximum or if the input voltage is distorted.

The ACF signal is an open collector output, and the emitter is connected to the DG terminal.

ACF signal may also be output in the following cases

- When the input voltage falls below the specifications

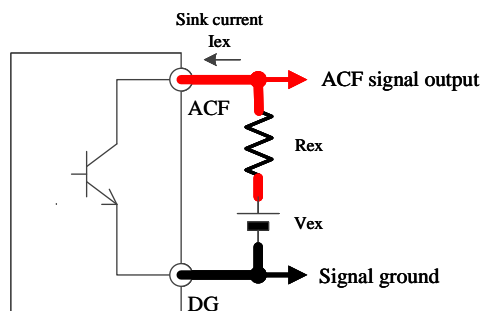

Requires a limit on sink current I_{ex} .

Select V_{ex} and R_{ex} so that I_{ex} is within the range of 0.1 to 20mA using the formula below.

V_{ex} is 1V or more and 30V or less.

$$I_{ex} = (V_{ex} - 0.3) / (R_{ex})$$

6-19. Communication function

Built-in communication function using RS-485 interface.

Using the Modbus-RTU protocol, it is possible to monitor the power supply operating status and change various settings.

When communication is enabled, various setting values are retained even if the input voltage is cut off.

Additionally, information such as cumulative operating time and product information is recorded in internal non-volatile memory, so it can be retained even if the input voltage is cut off.

Refer to the communication manual for details.

<Communication function example>

- monitoring : Power supply operating status can be read.
ex. Output voltage, output current, power supply ambient temperature, various protection operations, etc.
- Display log : Operation history can be read.
ex. Cumulative operating time, protection operation history, input voltage shortage alarm, etc.
- Setting value change : Output voltage and output current settings can be changed.
Real-time control of constant voltage output setting value and constant current output setting value is also possible.
The output rise time can also be changed.
- Output ON/OFF : Output ON/OFF can be controlled while maintaining the input application state.
- Product information : Product information can be read
ex. Model name, serial number, lot number, firmware version, etc.
- communication settings : Address, communication speed, parity bit, and stop bit can be set.

6-20. Isolation test

Isolation resistance between Output - \perp terminal is more than 100M Ω at 500VDC.
For safety operation, voltage setting of DC isolation tester must be done before the test.
Ensure that the unit is fully discharged after the test.

- Output - \perp terminal : 500VDC More than 100M Ω

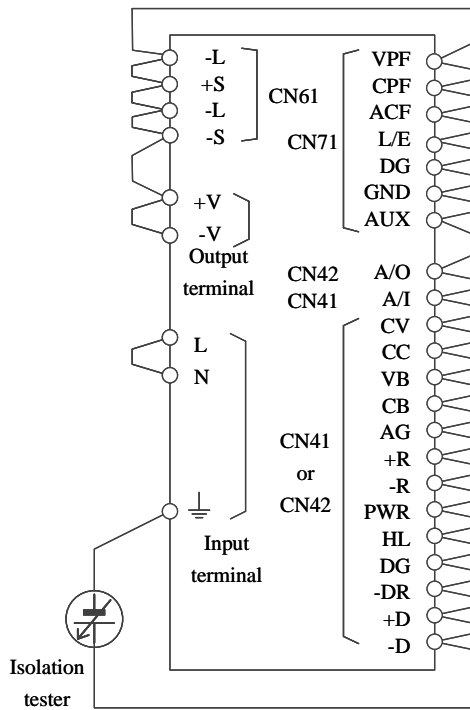

6-21. Withstand voltage

This series is designed to withstand 2.0kVAC between input and \perp terminal (FG), 3.0kVAC between input and output, 3.0kVAC between input and signal, AUX terminal, 2.0kVAC between output and signal, AUX terminal, 1.5kVAC between output and \perp terminal (FG) and each for 1 minute.

In the withstand voltage tester, set current limit of the withstand voltage tester at 20mA.

The applied voltage must be gradually increased from zero to test value and then gradually decreased for shut down.

When timer is used, the power supply might be damaged by high impulse voltage at switch on and off timing. Connection as follows.

- Input - \perp terminal (solid line) : 2.0kVAC 1min (20mA)
- Input - Signal, AUX terminal : 3.0kVAC 1min (20mA)
- Input - Output (dotted line) : 3.0kVAC 1min (20mA)

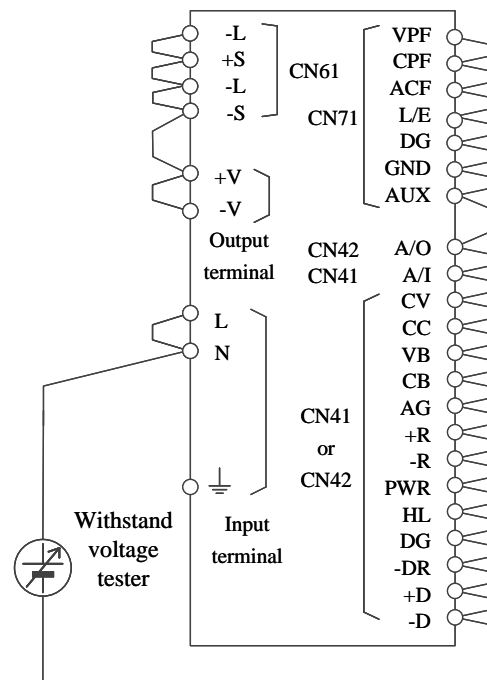
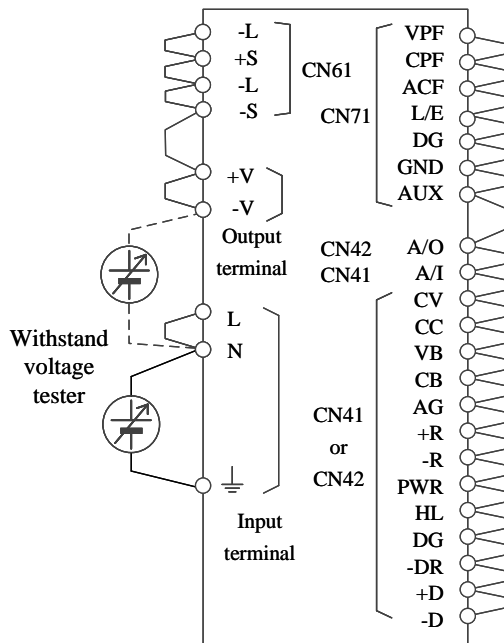

[TOP](#)

- Output - Signal, AUX terminal : 2.0kVAC 1min (20mA)
- Output - \perp terminal : 1.5kVAC 1min (20mA)

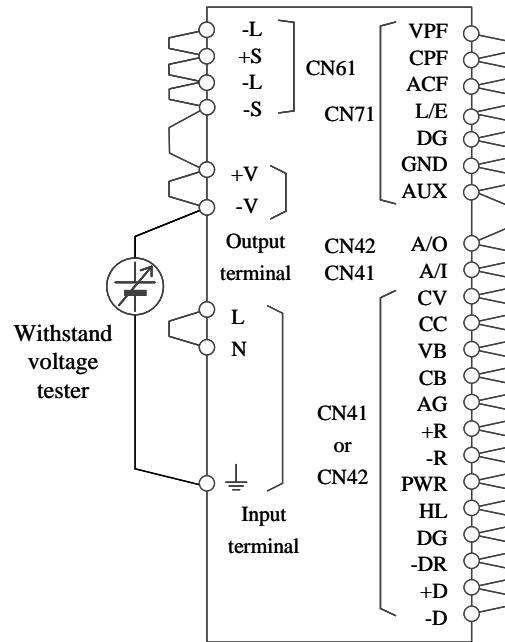
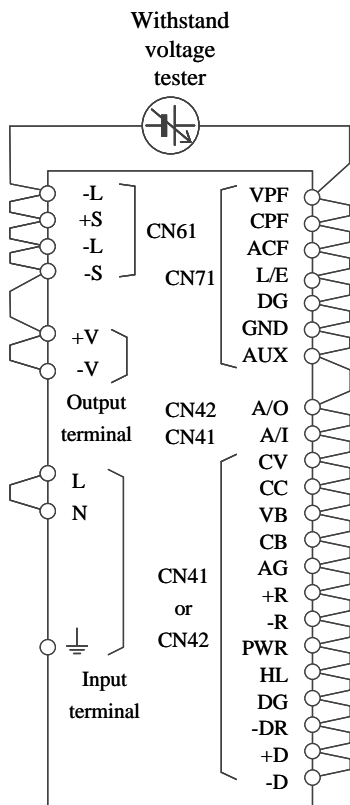

7. Block diagram

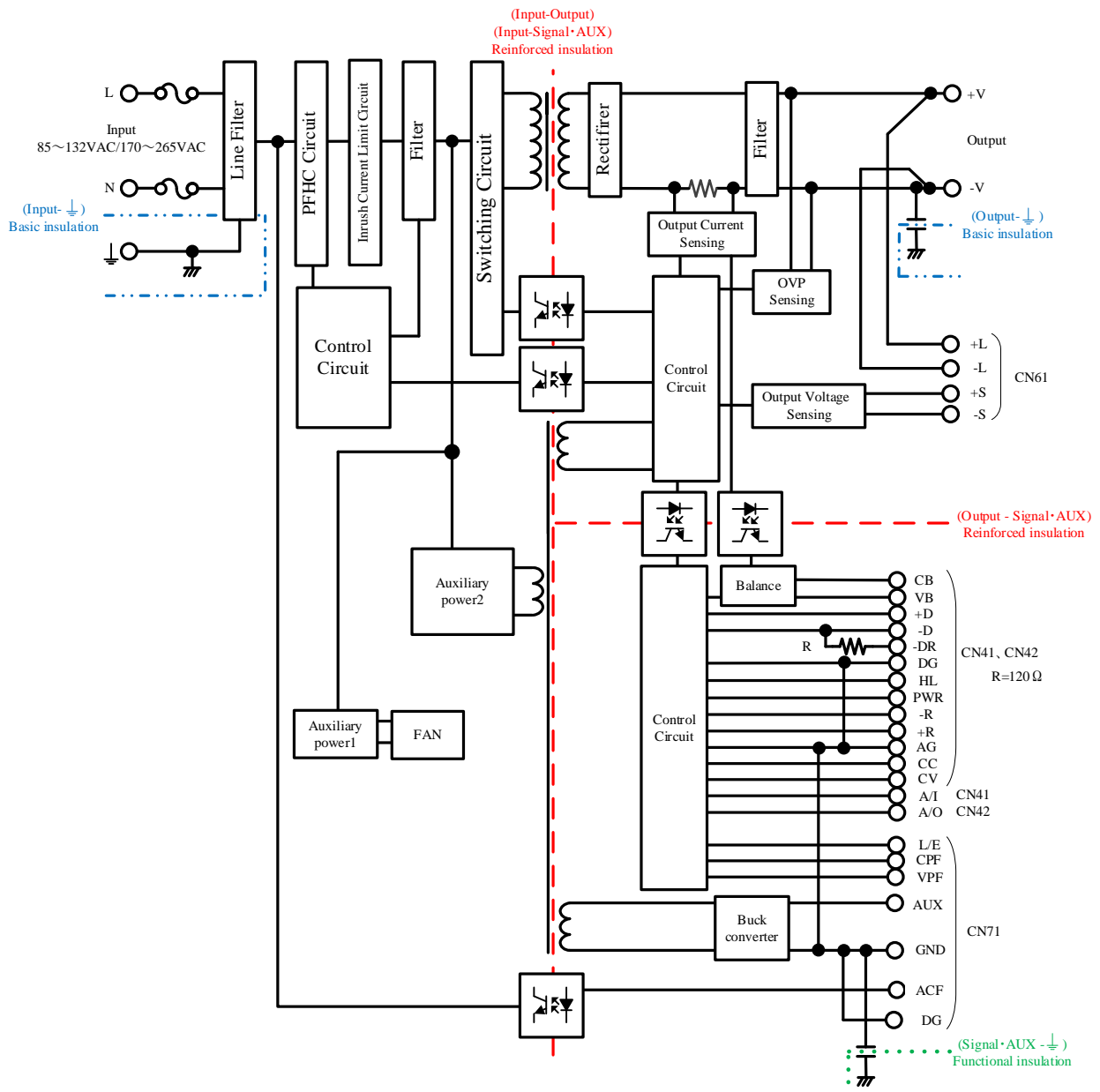

- Circuit topology, switching frequency
 PFHC circuit : Active filter 100kHz
 Switching Circuit : Full-Bridge converter 120kHz (Primary circuit), 240kHz (Secondary circuit)
 Auxiliary power1: Flyback converter 125kHz
 Auxiliary power2: Flyback converter 77kHz
 Buck converter (AUX): Buck converter 300kHz
- Fuse rating : 30A
 Parts name : 0324030
 Manufacturer name : Littell fuse

8. Sequence time chart

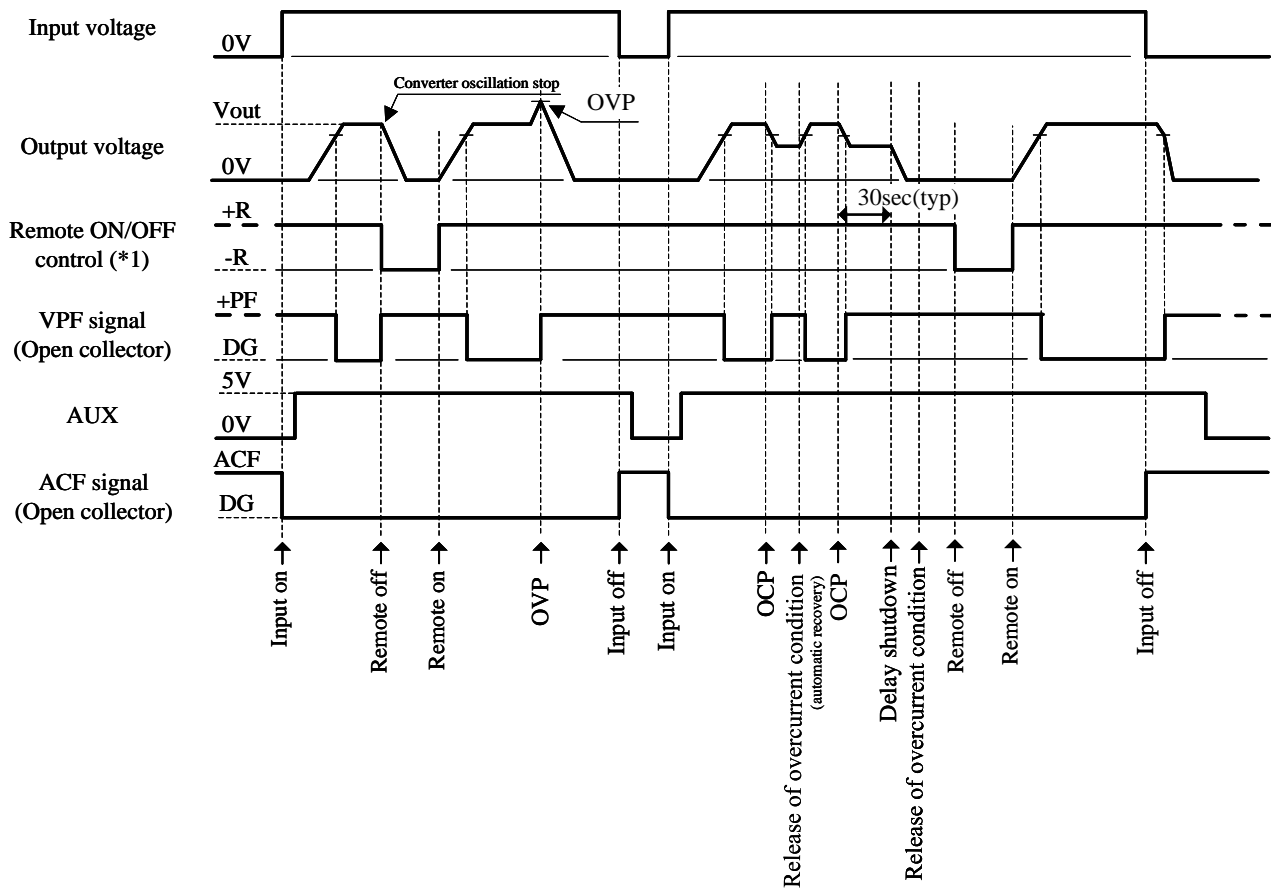

- (*1) Sequence for remote ON/OFF control by applying external voltage
+R to -R terminal voltage
- 4.5V or more : Output ON
 - 0.5V or less : Output OFF

9. External fuse rating

Refer to the following fuse rating when selecting the external input fuse.

Surge current flows when input turn on. Use slow-blow fuse or time-lag fuse. Fast-blow fuse can not be used.

Fuse rating is specified by inrush current value at input turn on.

Do not select the fuse according to actual input current (rms.) values.

External fuse rating : 30A (Icp,mr \geq 100A , Icc \leq 1.5kA)

10. Before concluding that the unit is at fault...

Before concluding that the unit is at fault, make the following checks.

- (1) Check if the rated input voltage is connected.
- (2) Check if the wiring of input and output is correct.
- (3) Check if the wire size is not too thin.
- (4) Check if the output voltage control (V.ADJ) is properly adjusted.
- (5) Check if the Remote sensing terminal is not opened.
In an open state, the output stability and accuracy will deteriorate.
- (6) Check if the output current and output power are not over specifications.
- (7) Audible noise can be heard when input voltage waveform is not sinusoidal wave.
- (8) Audible noise may be generated from the power supply depending on the frequency at which the load fluctuates.
- (9) Check that the remote ON/OFF control terminal is connected as specified.
- (10) Check if the built-in fan has stopped.
Check that the fan is not stopped due to foreign matter, dust, etc.
When the fan is stopped, the protection function cuts off the output.
- (11) Power supply has ventilating holes on the front and back panels.
Check for ventilation problems due to foreign matter or dust.
- (12) When using in constant voltage output mode:
Check that there is no external voltage applied to the CC terminal.
It may be operating in constant current output mode.
- (13) When using constant current output mode:
Check that there is no external voltage applied to the CV terminal.
It may be operating in constant voltage output mode.
- (14) Check that the wiring to the signal connector is connected correctly.

11. The life expectancy

The life of the power supply depends on the life of the built-in aluminum electrolytic capacitor being used and mounted fan. Each life is described in reliability data.

The life of the aluminum electrolytic capacitor varies depending on the method of the load current, and the ambient temperature. Please refer to "Electrolytic Capacitor Lifetime".

The life of the fan depends on the fan intake or exhaust temperature.

Please refer to "Fan Life Expectancy".

Please do not use the product which passed over the life expectancy.

There is a risk of unexpected output shutdown and specifications may not be satisfied.

Please contact us for maintenance or exchange the product which passed over the life expectancy.

12. Warranty period

This product is warranted for a period of 5 years from the date of shipment.

For damages occurring at normal operation within this warranty period, repair is free of charge.

13. CE MARKING / UKCA MARKING

CE MARKING

CE Marking, when applied to a product or packing material for a product covered by this handbook, indicates compliance with the Low Voltage Directive, EMC Directive and RoHS Directive.

UKCA MARKING

UKCA Marking, when applied to a product or packing material for a product covered by this handbook, indicates compliance with the Electrical Equipment (Safety) Regulations, Electromagnetic Compatibility Regulations and Restriction of the Use of Certain Hazardous Substances in Electrical & Electronic Equipment Regulations.