

# *PF1500B-360 Series*

## *Instruction Manual*

### **BEFORE USING THE POWER SUPPLY UNIT**

Be sure to read this instruction manual thoroughly before using this product. Pay attention to all cautions and warnings before using this product. Incorrect usage could lead to an electrical shock, damage to the unit or a fire hazard.

#### **⚠ DANGER**

- Never use this product in locations where flammable gas or ignitable substances are present.

#### **⚠ INSTALLATION WARNING**

- When installing, ensure that work is done in accordance with the instruction manual. When installation is improper, there is risk of electric shock and fire.
- Installation shall be done by Service personnel with necessary and appropriate technical training and experience. There is a risk of electric shock and fire.
- Do not cover the product with cloth or paper etc. Do not place anything flammable around. This might cause damage, electric shock or fire.

#### **⚠ WARNING on USE**

- Do not touch this product or its internal components while circuit in operation, or shortly after shutdown. You may receive a burn.
- While this product is operating, keep your hands and face away from it as you may be injured by an unexpected situation.
- There are cases where high voltage charge remains inside the product. Therefore, do not touch even if they are not in operation as you might get injured due to high voltage and high temperature. You might also get electric shock or burn.
- Do not make unauthorized changes to this product nor remove the cover as you might get an electric shock or might damage the product. We will not be held responsible after the product has been modified, changed or disassembled.
- Do not use this product under unusual condition such as emission of smoke or abnormal smell and sound etc. Please stop using it immediately and shut off the product. It might lead to fire and electric shock. In such cases, please contact us. Do not attempt repair by yourself, as it is dangerous for the user.
- Do not operate and store these products in environments where condensation occurs due to moisture and humidity. It might lead fire and electric shock.
- Do not drop or apply shock to this product. It might cause failure. Do not operate these products mechanical stress is applied.

#### **⚠ CAUTION on MOUNTING**

- Confirm connections to input terminals, output terminals and signal terminals are correct as indicated in the instruction manual before switching on.
- Input voltage, Output current, Output power, Base-plate temperature, ambient temperature and ambient humidity should be kept within specifications, otherwise the product will be damaged or malfunctioned.
- Input line and output line, please use the wires as short and thick as possible.
- Do not use this product in special environment with strong electromagnetic field, corrosive gas or conductive substances and direct sunlight, or places where product is exposed to water or rain.
- Mount this product properly in accordance with the instruction manual, mounting direction and shall be properly be ventilated.
- Please shut down the input when connecting input and output of the product.
- When mounted in environments where there is conductive foreign matter, dust or liquid, there is possibility of product failure or malfunction. Such as install filter, please consider that a conductive foreign matter, dust and liquid do not invade inside the power supply.

**⚠ CAUTION on USE**

- Product individual notes are shown in the instruction manual. If there is any difference with common notes, individual notes shall have priority.
- Before using this product, be sure to read the catalog and instruction manual. There is risk of electric shock or damage to the product or fire due to improper use.
- Input voltage, Output current, Output power, Base-plate temperature, ambient temperature and ambient humidity should be kept within specifications, otherwise the product will be damaged or malfunctioned, or cause electric shock or fire.
- Input voltage is that takes into consideration each country's standard input voltage and tolerance range.
- Take care input voltage rating is single phase and not to apply input voltage which is out specified range nor should a DC input voltage be applied as this would result into power supply damage.
- For products without built-in protection circuit (element, fuse, etc.), insert fuse at the input to prevent smoke, fire during abnormal operation.
- For externally mounted fuse do not use other fuses aside from our specified and recommended fuse.
- As our product is standard industrial use product that was manufactured by purpose that is used to an general electronics equipment etc., it is not products that to designed for High Safety uses (Uses extremely high reliability and safety are required, if reliability and safety has not been secured, with significant dangerousness for directly life or body) is expected. Please consider a fail safe (systems that was provided with protection circuit protective devices or systems that redundant circuit was mounted so that was not unstable in single failure) design enough.
- When used in environments with strong electromagnetic field, there is possibility of product damage due to malfunction.
- When used in environment with corrosive gas (hydrogen sulfide, sulfur dioxide, etc.), there is possibility that they might penetrate the product and lead to failure.
- When used in environments where there is conductive foreign matter, dust or liquid, there is possibility of product failure or malfunction.
- Do not operate and store this product in an environment where condensation might occur. In such case, waterproof treatment is necessary.
- Provide countermeasure for prevention of lightning surge voltage as there is risk of damage due to abnormal voltage.
- Connect together the frame ground terminal of the product and the ground terminal of the equipment for safety and noise reduction. If these ground is not connected together, there is risk of electric shock.
- Take care not to apply external abnormal voltage to the output terminals and signal terminals. Especially, applying reverse voltage or overvoltage more than the rated voltage to the output might cause failure, electric shock or fire.
- Do not use this product in special environment with strong electromagnetic field, corrosive gas or conductive substances and direct sunlight, or places where product is exposed to water or rain.
- Never operate the product under overcurrent or short circuit condition. Insulation failure, or other damages may occur.
- Protection must be provided for Service Engineers against indirect contact with the output terminals and/or to prevent tools being dropped across them. While working on this product, the AC input power must be switched off and the input, output, +V, -V and R terminal voltage should be safe level.
- The application circuits and their parameters are for reference only. Be sure to verify effectiveness of these circuits and their parameters before finalizing the circuit design.
- Take care when used at below -20 ambient temperature, AC ripple of boost voltage, output ripple voltage might be affected by ESR characteristics of the bulk capacitors. In this case, the maximum allowable ripple voltage must be considered when selecting the capacitance, and the capacitance selected must not exceed the maximum allowable value in the instruction manual. Therefore, be sure to verify characteristic by actual performance. Therefore, it is important to verify features against actual performance.
- Take care when soldering the connector pins of the power supply installed on the PCB board, ensure that the power supply is reliably locked with screws before soldering to prevent damage.
- Excessive stress could cause damage. Therefore, please handle with care.

**⚠ Note**

- Consider storage of the product at normal temperature and humidity avoiding direct exposure to sunlight at environment with minimal temperature and humidity changes. Storage of product at high temperature, high humidity and environments with severe changes in temperature and humidity might cause deterioration, and occurrence of condensation in the product.
- When disposing product, follow disposal laws of each municipality.
- Published EMI (CE, RE) or immunity is the result when measured in our standard measurement conditions and might not satisfy specification when mounted and wired inside end-user equipment. Use the product after sufficiently evaluating at actual end-user equipment.
- When exporting our products, apply for necessary permissions as required by rules and regulations of Foreign Exchange and Foreign Trade Control Act.
- The information in this document is subject to change without prior notice. Please refer to the latest version of the data sheet, etc., for the most up-to date specifications of the product.
- No part of this document may be copied or reproduced in any form without prior written consent TDK-Lambda.

**⚠ LONG-TERM STORAGE METHOD AND LONG-TERM STORAGE PERIOD**

- Please keep the product in carton box.
- Please do not apply excessive vibration, shock or mechanical stress applied directly to the product.
- Please keep away from direct sunlight.
- For long-term storage temperature and humidity, the following conditions shall be used as a guideline :
  - Temperature range : 5°C~30°C
  - Humidity range : 40%~60%RH
  - Please keep away from the places where temperature and humidity can change drastically.
  - It can cause condensation on the product or deterioration.
- For long-term storage period, we recommend to use within 2 years after receiving the product.
  - For products that have been received for more than 1 year, please check lead oxidation and solderability.
  - In addition, SMD type products may have MSL (Moisture Sensitivity Level) provision.
  - Please be sure to read the instruction manual and delivery specifications.

1. Model name identification method

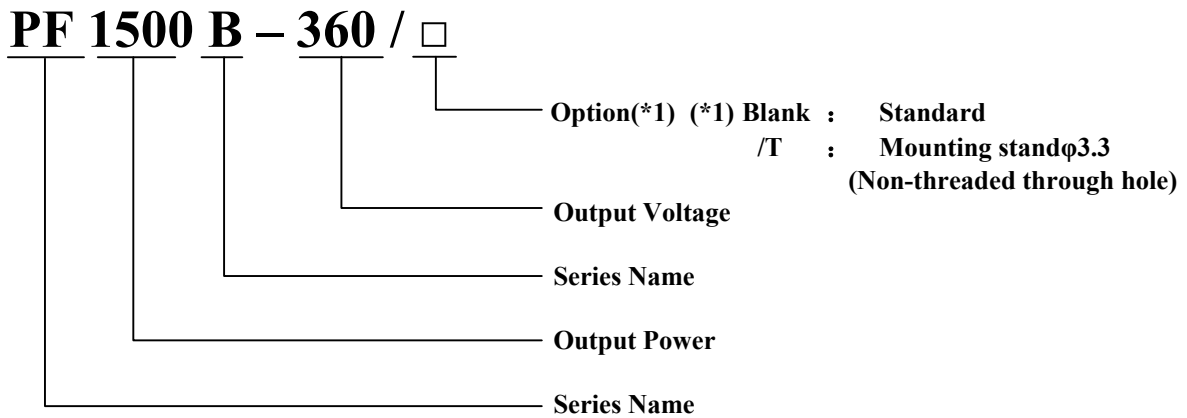

2. Terminal Explanation

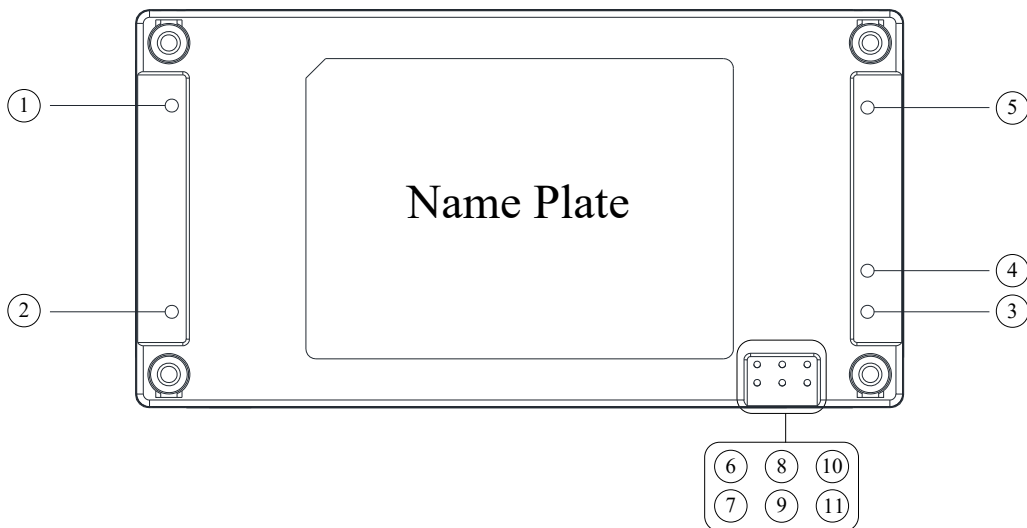

- ① AC(L) : Input terminal neutral line
- ② AC(N) : Input terminal live line
- ③ +V : +Output voltage terminal
- ④ -R : External inrush current limiting resistor terminal
- ⑤ -V : -Output voltage terminal
- ⑥ ENA : Output load enable terminal
- ⑦ AUX : Auxiliary power supply terminal for external circuits
- ⑧ PC : Output current balance terminal ( Parallel control )
- ⑨ CNT : ON/OFF control terminal
- ⑩ SG : Common signal ground terminal
- ⑪ IOG : Inverter operation good terminal

- Base-plate can be connected to FG through by M3 Mounting tapped holes.
- Consider contact resistance when connecting AC(L), AC(N), +V, -V, R.
- Note that +V, R and -V terminals are primary voltage with high voltage (360VDC).

### 3. Block Diagram

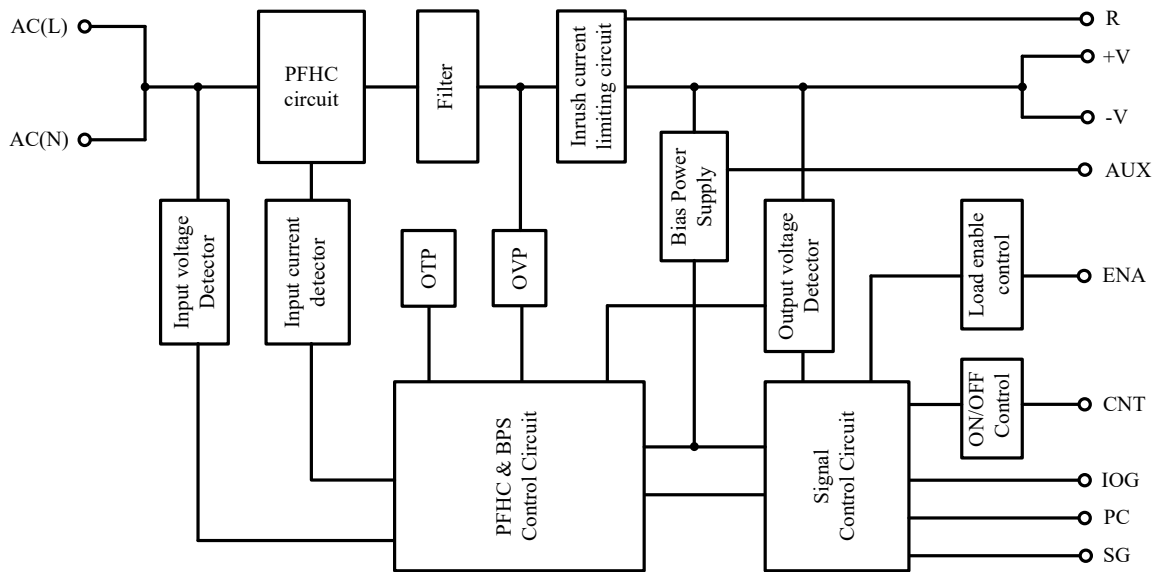

Switching Frequency(fixed) : 127kHz  $\pm$  10kHz

### 4. Sequence Time Chart

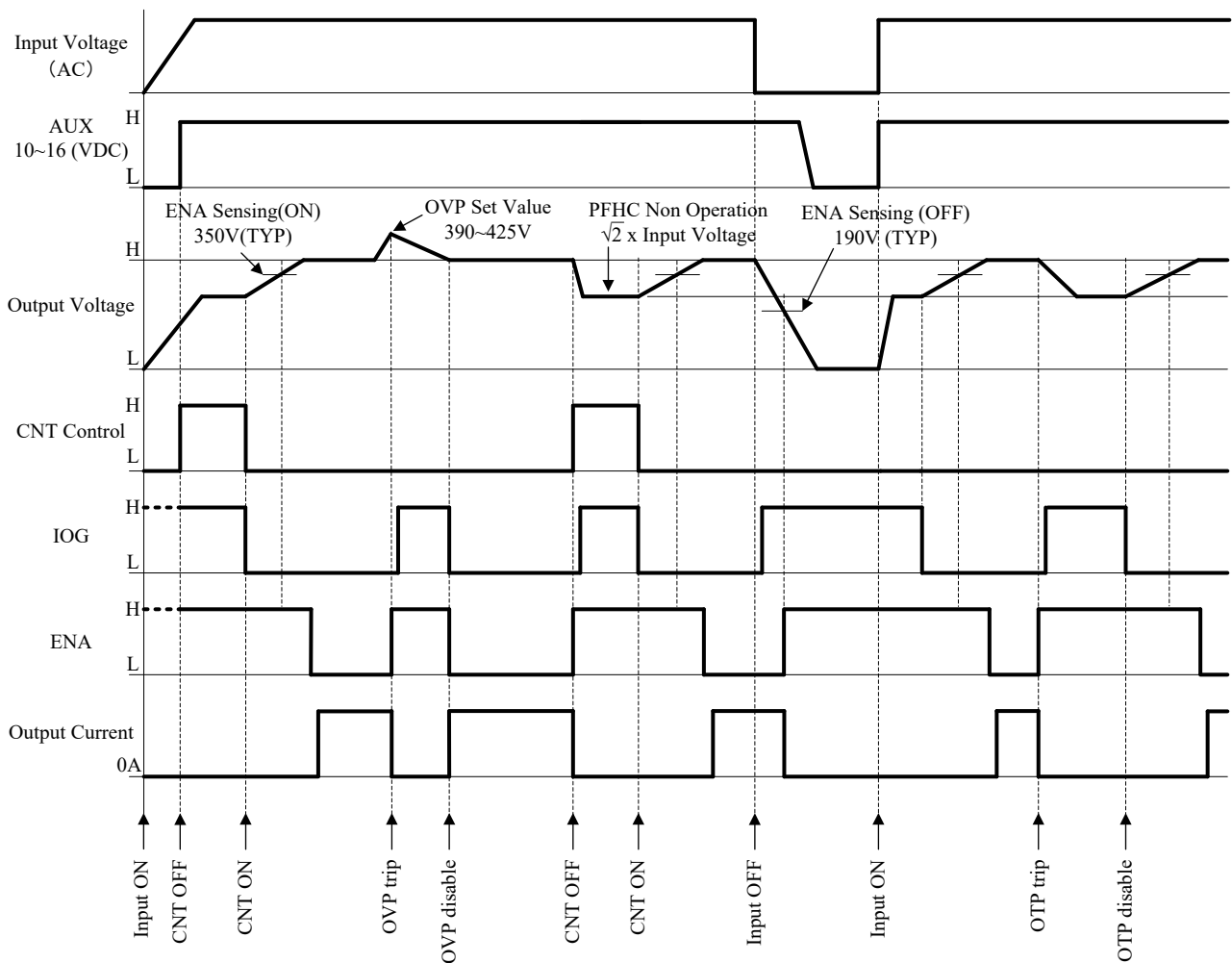

## 5. Terminal connecting method

In order to use the PF1500B Series, this module must be connected with external components according to Fig.5-1.

Pay attention to the each wiring. If it is connected to wrong terminal, the power supply will be damaged. PF1500B series employs conduction cooling method. Use heat sink and fan to dissipate heat.

For selection of heat sink and heat sink dissipation method, refer to the Power Module Application Note. External noise filter should be connected in order to meet EMI, EMS requirement. Refer to Evaluation data, Reliability data and IEC61000 Test data of PF1500B series.

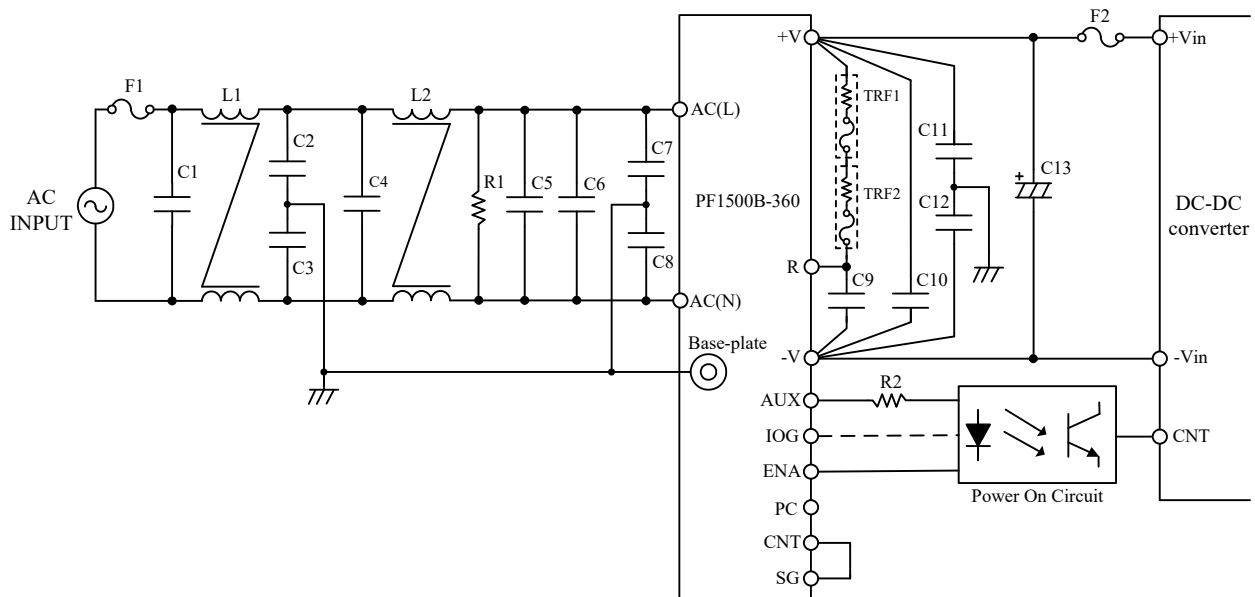

Fig.5-1 Basic connection

### ■ External Components

#### C1, C4, C5, C6 : 1uF or more ( Film Capacitor )

Ripple current flows through this capacitor. When selecting capacitor, be sure to check the allowable maximum ripple current rating of this capacitor. Verify the actual ripple current flowing through this capacitor by doing actual measurement.

Connect C5, C6 as close as possible toward the input terminals AC(N) and AC(L) of this power module.

Recommend to use 275VAC or higher rating voltage with safety approved capacitor and the AC ripple current must be rated for more than 3A(RMS) per capacitor.

#### C2, C3, C7, C8, C11, C12 : 2200pF ( Ceramic Capacitor )

Add ceramic capacitor as EMI/EMS countermeasure. Be sure to consider leakage current of your equipment when adding this capacitor.

High withstand voltage are applied across this capacitor depending on the application. Select capacitor with high withstand voltage rating.

Connect C7 as close as possible to AC(L) terminal, C8 as close as possible to AC(N) terminal.

Connect C11 as close as possible to +V terminal, C12 as close as possible to -V terminal.

**C9, C10 : 2.2uF or more ( Film Capacitor )**

Capacitor is used to snub spike noise emanating from the boost inverter particularly when the main switch turns off.

Ripple current flows through this capacitor. When selecting capacitor, be sure to check the allowable maximum ripple current rating of this capacitor. Verify the actual ripple current flowing through this capacitor by doing actual measurement.

Connect C9 as close as possible to R terminal and -V terminal, C10 as close as possible to +V terminal and -V terminal.

It is recommended DC450V rated voltage and the AC ripple current rating must be rated for more than 3A(RMS) per capacitor.

**C13 : 470uF ~ 2700uF ( Electrolytic Capacitor )**

Refer to “ ● Selection Method of External Bulk Capacitor for Boost Voltage ” below.

Allowable external capacitance at nominal capacitance value is shown below.

Recommended voltage rating : 450VDC

Recommended total capacitance : 470uF ~ 2700uF (470uF not full load)

Note) 1. Do not connect capacitors with more than the above capacitance value as this would result into power module damage.

2. The minimum value at 470uF does not mean that it can operate at full power, and reducing the bulk capacitance will affect the output hold time, dynamic line response and dynamic load response characteristics.

2. When using module below -20°C ambient temperature, AC ripple of boost voltage, output ripple voltage might be affected by ESR characteristics of the bulk capacitors. Therefore, be sure to verify characteristics by actual evaluation.

3. Use low impedance electrolytic capacitor with excellent temperature characteristics.

(Nippon Chemi-con KXN Series or equivalent)

**TRF1, TRF2 : 10Ω ~ 20Ω ( Total value : TRF1 + TRF2 = 10Ω ~ 20Ω )**

By connecting thermal fuse resistor across R and +V terminals as shown in Fig.5-1, in-rush current during line throw-in can be suppressed. Failures due to in-rush current such as melting of external fuse, welding of relay or switch connecting joints or shutdown of No-Fuse Breakers (NFB) can occur.

Therefore, be sure to connect this external thermal fuse resistor of 10Ω or more.

Refer to “ 6-10. Input In-rush current ”.

Note) that power supply will not operate if this external resistor is not connected.

**F1: External Input Fuse**

PF1500B Series has no internal fuse. Use external fuse to acquire each safety standard and to further improve safety.

PF1500B Series acquired safety standard certification using 20A, 250V, Fast-Blow external fuse.

Further, Fast-Blow type fuse must be used per one module. Also, in-rush surge current flows during line throw-in. Be sure to check I<sup>2</sup>t rating of external switch and external fuse.

Note) Select fuse based on rated voltage, rated current and surge current capability.

Please refer to “ 6-10. Input In-rush current ”.

**F2 : External Output Fuse**

In order to protect the load from damage, please use an external fuse (Fast Blow Type).

Recommended output fuse : 500VDC, 6.3A

**L1 : 4.5mH minimum ( Common mode choke )**

**L2 : 1.3mH minimum ( Common mode choke )**

Add common mode choke coil as EMI/EMS countermeasure.

When using multiple modules, connect coil to each module.

Note) Depending on the input filter used, noise might increase or power module might malfunction due to filter resonance.

**R1 : 470kΩ ( Bleeder resistor )**

Connect bleeder resistor across AC(L) and AC(N) terminals.

**Power On Circuit :**

Please refer to “● Power On Signal”.

**● Selection Method of External Bulk Capacitor for Boost Voltage**

Boost voltage bulk capacitor is determined by the following factors:

- Peak to Peak output ripple voltage.
- Required hold-up time.
- RMS ripple current.
- Expected lifetime of the capacitor.

Select capacitor value such that boost voltage ripple voltage does not exceed 15Vp-p.

Note) When ambient temperature is -20°C or less, ripple voltage of boost voltage might increase due to ESR Characteristics. Therefore, verify above characteristics by actual operation temperature, but the maximum capacitance should not exceed 2700uF.

(1) Capacitance selection for desired peak to peak output ripple voltage

The peak to peak output ripple voltage should be minimized to less than 15Vp-p. This will ensure that DC voltage bus is fairly constant for line and load changes. The following formula determines the required output capacitance needed for a peak to peak ripple voltage of less than 15Vp-p.

$$C_o \geq \frac{P_{out}}{(2\pi f \times V_{p-p} \times V_o \times \eta)} \quad (F) \quad (\text{Formula 5-1})$$

$C_o$  : Output smoothing capacitance (F)

$P_{out}$  : Maximum output power (W)

$V_o$  : Rated output voltage (worst case = 98% of rated output voltage) (V)

$V_{p-p}$  : Output ripple voltage (less than 15V<sub>p-p</sub>) (V)

$\eta$  : Efficiency

$f$  : Input frequency (Hz)



(2) Capacitance selection for desired holdup time

The total output capacitance must also be calculated based on the required holdup time of the AC/DC power supply. The minimum capacitance corresponding to the required holdup time of a system comprised of the TDK-Lambda DC/DC power modules and an PFC module can be calculated following formula relates the output capacitance to the required holdup time below.

$$C_o \geq \frac{2 \times P_{out} \times T_{holdup}}{(V_o - V_{p-p} / 2)^2 - (V_{min})^2} \quad (F) \quad (\text{Formula 5-2})$$

- $C_o$  : Output capacitance (F)
- $P_{out}$  : Maximum output power (W)
- $V_o$  : Rated output voltage (worst case = 98% of rated output voltage) (V)
- $V_{p-p}$  : Output ripple voltage (less than  $15V_{p-p}$ ) (V)
- $T_{holdup}$  : Required holdup time of AC/DC power supply (sec)
- $V_{min}$  : Minimum output voltage( 200V) that maintains the ENA signal at low level (V)

For output holdup time, Refer to separate document “PF1500B Series Evaluation Data” and use appropriate capacitor up to 2700uF maximum.

It is recommended that verification should be done through actual evaluation.

(3) RMS ripple current for the output capacitor

The peak to peak ripple current is comprised of both line frequency and switching frequency components. In a power factor corrected system, the AC peak to peak ripple current is greatly reduced. This is due to the regulated DC bus of 360VDC that the capacitor sees even over wide input variations. This allow for a smaller capacitor that can consistently store more energy than in the conventional system at low line. All of this result in a charging current waveform that has a peak to peak value of only twice the DC input current. That means that the RMS capacitor current is equal to  $0.707 \times IDC$ . This increases the reliability of the overall front end which extends itself to a better system design.

The maximum allowable ripple current of the capacitor must be greater than the actual ripple current value. The Fig.5-2 below shows actual ripple current versus output power. This can be used as an estimation for actual peak to peak ripple current. However, measurement of the actual current should be made to confirm system reliability.

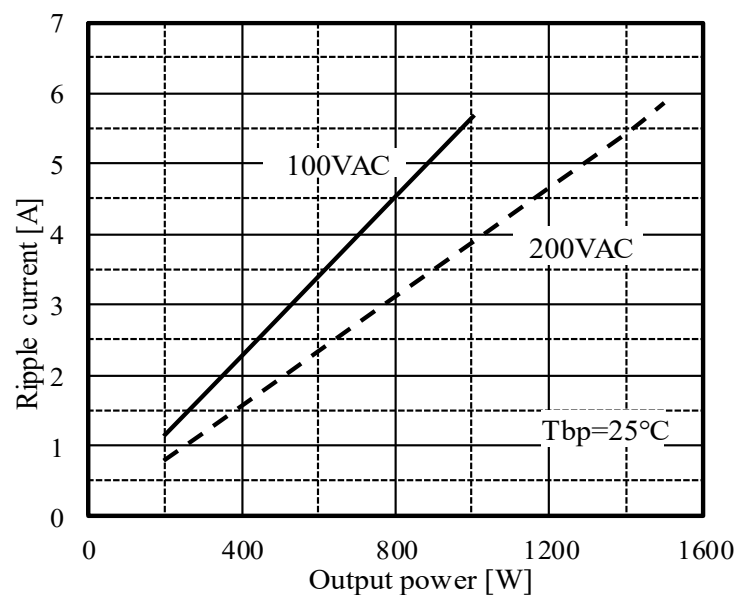

Fig.5-2 Allowable ripple current value

The recommended boost voltage bulk capacitance value is 470uF – 2700uF.

When using with reduced the bulk capacitance value, it is necessary to reduce output power as shown in Fig.5-3.

Fig.5-3 shows recommended value at 25°C baseplate temperature. Temperature variance might have some effect on the characteristics. Therefore, verify characteristics by performing actual evaluation. Refer to “Fig.6-6 Baseplate Measuring Point”.

Note that reducing the bulk capacitance affects output holdup time, dynamic line response and dynamic load response characteristics. It is recommended that verification should be done through actual evaluation.

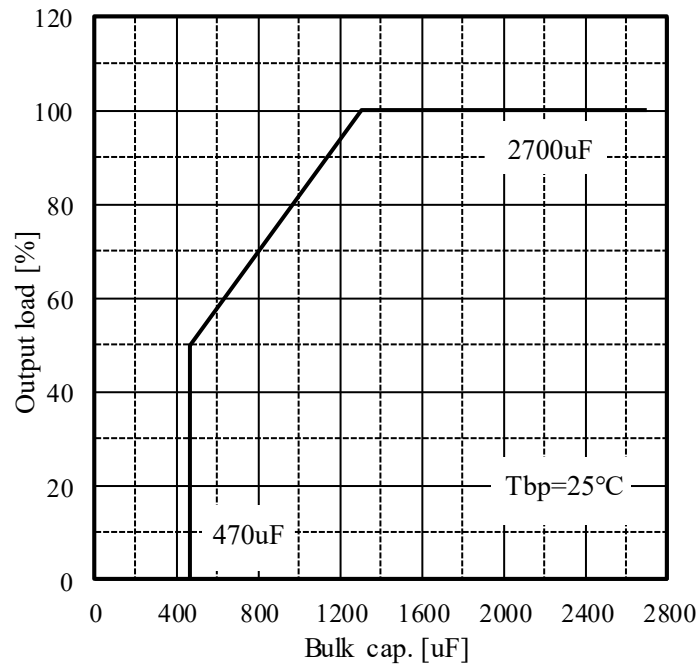

Fig.5-3 Output Load v.s. Boost Bulk Capacitance

## 6. Explanation of Functions and Precautions

### 6-1. Input Voltage Range

Input Voltage that takes into consideration each country’s standard input voltage and tolerance range. The PF1500B modules input voltage rating is single phase 85~265VAC, at a frequency range of 47~63Hz.

Take care not to apply input voltage which is out specified range nor should a DC input voltage be applied as this would result into power supply damage.

For case where conformance to various safeties required, described as 100-240VAC(50-60Hz).

### 6-2. PFHC Operation Input Voltage Range

PFHC operation will not occur with input voltage above 255VAC. The output voltage will be the full rectification of the input voltage.

### 6-3. Input Current

This is the effective value of the current supplied to the module. The value in the specifications is the value under standard input and output.

### 6-5. Maximum Output Current

This is the maximum output current the module can supply to the load continuously.

### 6-6. Maximum Output Power

This is the maximum output power the module can supply to the load continuously.

The PF1500B has the capability of supplying 1000W in the 100VAC input mode and 1500W in the 200VAC input mode.

The increased wattage capability at 200VAC input is primarily due to the higher efficiency achieved as compared to (93.5%) when operating in the 100VAC mode.

### 6-7. Efficiency

This is the ratio of the output power to the effective input power. The value in the specifications is the efficiency under standard input and output. Due to the fact that the efficiency will change with input voltage and output power, please take caution when constructing thermal design.

### 6-8. Power Factor

The percentage of effective input power vs. the apparent input power is called power factor.

### 6-9. Output Voltage Accuracy

Within the PFHC operating input voltage range, the output voltage accuracy is 360VDC  $\pm$  2%.

### 6-10. In-rush Current

In-rush current is defined as the initial peak input current drawn by the input capacitors during turn-on. This current can be very large depending on the source impedance, and can cause such problem as external fuse brown-out, melting of contacts of a relay or tripping of a circuit breaker.

This in-rush current at turn-on can be limited by connecting an external resistor between the R and +V terminals on the PF module. This allows flexibility for the user to reduce the in-rush current to meet his or her design conditions.

Note : The PF-B module must be operated with an external in-rush limiting resistor.

#### ● Selection of An External In-rush Limiting Resistor

##### (1) Calculating Resistance Value for TFR1+TFR2

Resistance can be calculated by the formula below.

$$R = \frac{V_{\text{inpk}}}{I_{\text{in-rush}}} \quad (\Omega) \quad \text{(Formula 6-1)}$$

R : Resistance Value for External TRF1+TRF2 ( $\Omega$ )

$V_{\text{inpk}}$  : Input Voltage converted to DC value = Input Voltage (rms)  $\times \sqrt{2}$  (V)

$I_{\text{in-rush}}$  : Input surge current value (A)

##### (2) Required Surge Current Rating

Sufficient surge current withstand capability is required for external TFR1+TFR2.

Required surge current rating can be selected by  $I^2t$ . (Current squared multiplied by time)

$$I^2t = \frac{C_o \times V_{\text{inpk}}^2}{2 \times R} \quad (\text{A}^2\text{s}) \quad \text{(Formula 6-2)}$$

$I^2t$  : Current-squared multiplied by time ( $\text{A}^2\text{s}$ )

$C_o$  : Output Bulk Capacitance (F)

$V_{\text{inpk}}$  : Input Voltage converted to DC value = Input Voltage (rms)  $\times \sqrt{2}$  (V)

R : Resistance Value for External TRF1+TRF2 ( $\Omega$ )

It is recommended to use a thermally fused inrush limiting resistor or a resistor with a thermal fuse in series for safety protection.

● **Selection of an external input fuse**

The power module does not provide an input fuse. For safety precautions and to meet each safety approval standard, an external fuse should be connected (to each module).

(1) Voltage Ratings

100VAC line : AC125V  
 200VAC line : AC250V

(2) Current Ratings

Rated current is determined by the maximum input current based on operating conditions and can be calculated by the following formula.

$$I_{in} (\text{max}) = \frac{P_{out}}{V_{in} \times \eta \times PF} \quad (\text{Arms}) \quad (\text{Formula 6-3})$$

$I_{in} (\text{max})$  : Maximum Input Current  
 $P_{out}$  : Maximum Output Power  
 $V_{in}$  : Maximum Input Voltage  
 $\eta$  : Efficiency  
 $PF$  : Power Factor

For Efficiency and Power Factor values, refer to separate document “PF1500B Series Evaluation Date”.

(3) Calculating the Required Surge Energy

The surge energy when the in-rush current protection circuit does not function must be considered. If the output is above 200V when the input has been shut down, the in-rush current protection circuit will not function. Please refer to Sequence Timing Chart. At this time the in-rush current limiter is only the line impedance. The surge energy at this time can be calculated as follows.

$$I^2t = \frac{C_o \times (V_{inpk}^2 - 200^2)}{2 \times r} \quad (\text{A}^2\text{s}) \quad (\text{Formula 6-4})$$

$I^2t$  : Current-squared multiplied by time (A<sup>2</sup>s)  
 $C_o$  : Output Bulk Capacitance (F)  
 $V_{inpk}$  : Input Voltage converted to DC value = Input Voltage (rms)  $\times \sqrt{2}$  (V)  
 $r$  : Input Line Impedance ( $\Omega$ )

Line impedance will vary depending on conditions of use. However, when using calculations, please make this value 0.5  $\Omega$ .

The  $I^2t$  value of the manufacturers rating must be greater than the calculated value from Formula 6-4. The fuse must also be able to support the AC RMS input current as well as the AC RMS input voltage.

**6-11. Over Voltage Protection (OVP)**

This module is equipped with OVP function. OVP function operates within 390~425V. OVP value is fixed and cannot be set externally. During an OVP condition, the power factor correction function is disabled. The output DC bus voltage, however, is still maintained as a rectified AC input voltage. When the output less than 380V the OVP function reset.

Pay attention not to apply higher voltage externally to the output terminal to avoid power supply damage.

### 6-12. Over Temperature Protection (OTP)

This module is equipped with OTP function. This function will activate when the baseplate temperature rises above the trip point (105°C - 130°C). Once over temperature condition is detected, power factor correction is inhibited and only a rectified AC input voltage is provided as an output.

When the thermal protection triggers, please shut down the load through the IOG and ENA. Power factor correction is restored once the baseplate temperature has fallen to within operating limits and AC line voltage is reapplied.

### 6-13. ON/OFF Control (CNT terminal)

This module is equipped with CNT control function.

It is possible to ON/OFF control of power factor correction at input applied state by using this function. The ON/OFF control circuit is located at the primary side, Fig.6-1 and Fig.6-2 is connection example of ON/OFF control.

When the ON/OFF control is no used. Short CNT to SG terminals.

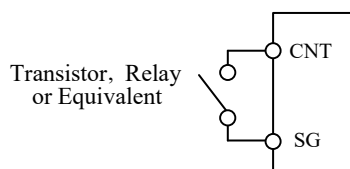

Fig.6-1 CNT Connection (1)

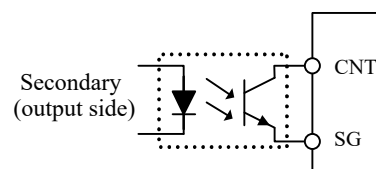

Fig.6-2 CNT Connection (2)

### 6-14. Power ON signal (ENA Terminal)

The PF1500B series is furnished with a power ON monitoring (ENA terminal) that is supplied as an open collector type. This signal is located at the primary side and monitors the output voltage of the PF module and indicates when it is at a high enough voltage to support proper operation. When the output voltage is at its proper level (greater than 350VDC), the power ON signal is in its low state.

Maximum sink current	: 5mA
Maximum applied voltage	: 50V

The power ON signal functions to ensure that the load of the PF-B module remains in the off state until the module reaches its appropriate output voltage. At initial turn on of a power supply, there exists a high peak inrush current that charge up the input capacitors. If a load is drawn from the bulk storage capacitors before the PF-B module reaches its normal operating voltage, the DC bus voltage can drop, causing a possible under voltage lockout condition. This can prohibit the PF-B module from operating properly. To prevent this from happening, the following circuitry should be added.

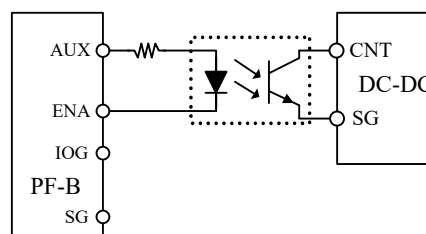

Fig.6-3 ENA Connection

The optically isolated circuit shown above uses the auxiliary bias supply of the PF-B module to “hold off” the PF-B module until sufficient voltage at the output of the PF-B module is reached.

Note: This circuit can also be controlled via an external 0-5VTTL signal in place of the auxiliary supply. The return of the ENA pin is the SG terminal.

### 6-15. Inverter Output Good signal (IOG Terminal)

Normal or abnormal operation of the power module can be monitored by using the IOG terminal. Output of this signal monitor is located at primary side and is an open drain output.

This signal is LOW when inverter is normally operating and HIGH when inverter stops or when inverter is operating abnormally.

Maximum sink current : 5mA  
 Maximum applied voltage : 30V

Ground for the IOG terminal is the SG terminal (SG is connected internally to the -V terminal). Connection circuitry for primary side or secondary side application please refer to below .

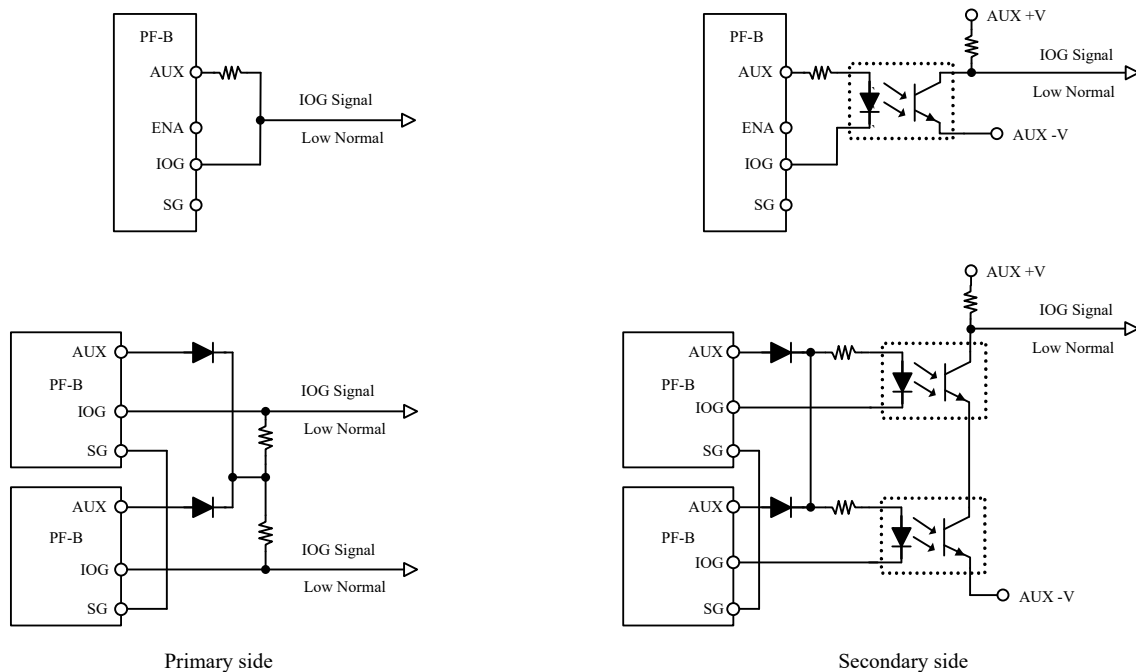

Fig.6-4 IOG Connection

Please take note that the time from when the PFHC goes off until the time the IOG goes high is more than 20s.

Also note that IOG becomes unstable for following conditions:

- Light load conditions
- Dynamic load operation

### 6-16. Auxiliary Power Supply for External (AUX terminal)

This module is equipped with an auxiliary power supply (AUX terminal) to provide power for external system or “housekeeping” circuitry. The output voltage value is within 10~16VDC range, maximum output current is 10mA. When using parallel operation, the AUX terminals should be diode isolated as shown in the diagram for IOG signal. In this case as well, the maximum output current is 10mA. The return for the AUX signal is the signal ground terminal (SG).

Avoid short circuit of AUX terminal with other terminals as this would lead to power module damage.

### 6-17. Signal Ground (SG terminal)

This module is equipped with signal ground for AUX, PC, IOG, CNT and ENA.

### 6-18. Parallel Operation (PC terminal)

The PF-B modules can be paralleled by connecting the PC pin from one module to another. This will allow equal current sharing of up to a maximum of 3 units in parallel (same power level). By connecting the PC terminals together, each module will sense and monitor its own output current via an analog voltage signal that is in proportion to the output current. The internal circuits of both modules will mutually monitor and compare the voltage of one another, so that balancing is achieved for both modules.

When operating in parallel, the maximum load current drawn from each unit is up to 90% of the maximum output current that appears on the modules specification sheet.

#### ● Application Note on Parallel Operation

Parallel operation is possible within the PFHC operating range (85~250VAC). When operating in parallel, connect the PC pins together and there will be current sharing between the models.

#### A. Basic Parallel Operation Connection

Parallel operation is used when there is not enough current to supply the load being used with one model, or when improving the reliability of the power supply by reducing the output power. However, if one model goes down, the output will be shut down. The basic connection is shown below.

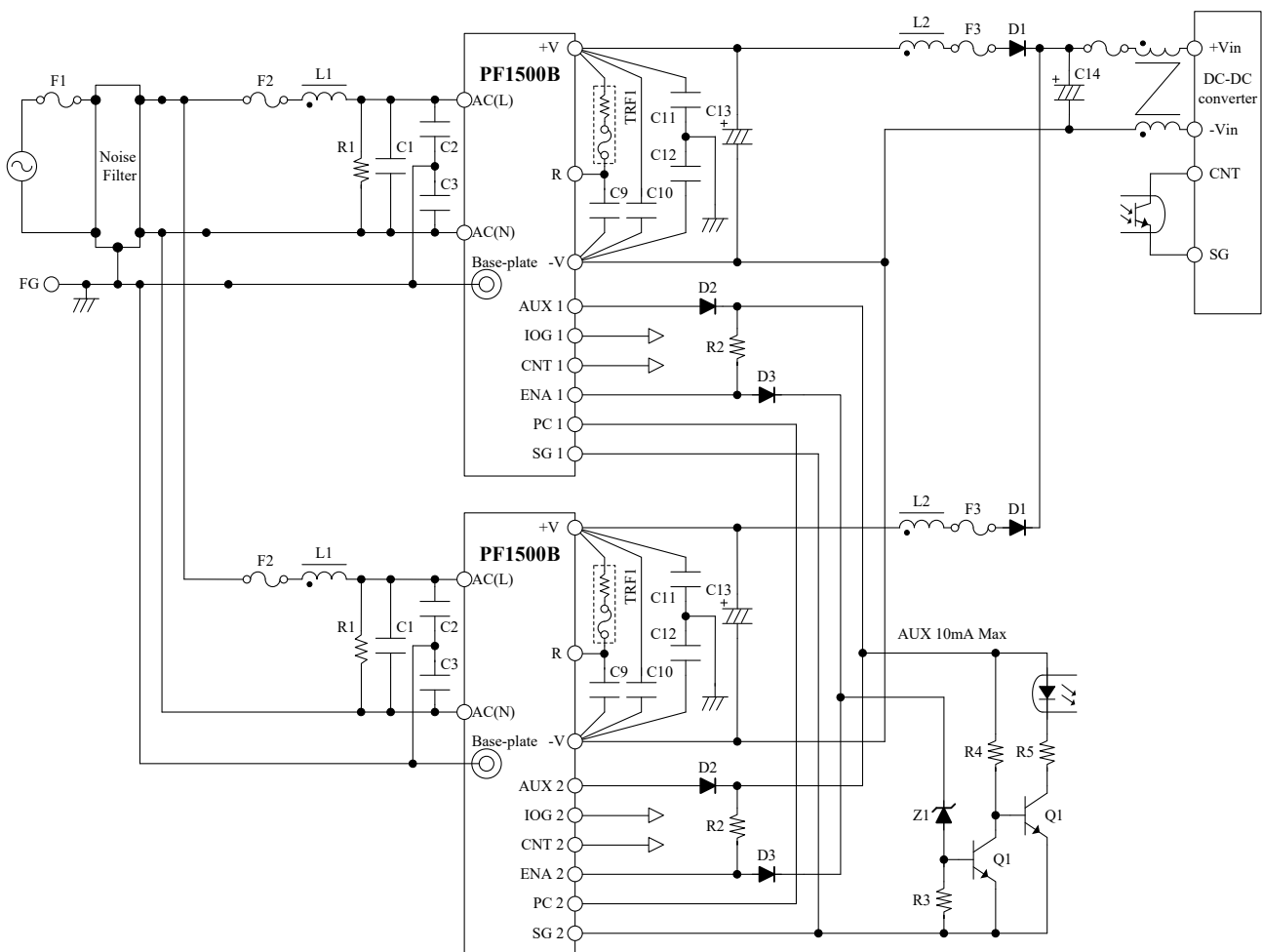

Fig.6-5 Basic Parallel Operation Connection

## **B. In Order to Operate in Parallel**

In order to operate in parallel, the following basic caution points should be considered.

- **Input Voltage Range : 85~250VAC**  
If this range is exceeded, there will be no current sharing and damage to the module could occur.
  - **Maximum Possible Modules in Parallel : 3 units** Models must be of similar type.
  - **Connection for Each Signal :**  
Make sure that the power on signal (ENA) and IOG signal (IOG) are used. Only when both of these signals are LOW, the operation is normal, and possible output is displayed. If one of the signal is abnormal (HIGH), the module is thought to be abnormal. Please make the output in "OFF" condition.
  - **SG Terminal Connecting:**  
The SG terminal is connected inside the module to the -V terminal. However, to make the module's operation more steady, discriminate from the output line (power line). To make the ground level even between each SG terminal, short each -V terminal to the SG terminal.
  - **Output Derating : Under 90%**  
When operating in parallel, derating is needed to achieve the current sharing accuracy. Please use at 90% or below of each module's maximum power rating. Further, take note that depending on the input voltage, the standard output will change.
  - **Output Smoothing Capacitor :**  
When operating in parallel, a situation will be produced where the output capacitance exceeds each PF-B series upper limit. The inrush current due to the output capacitor can damage the module. Therefore. In order to fulfill each module's maximum external output capacitance (inrush current capacitance), be sure to attach an output diode.
  - **Insertion of Normal Mode Choke Coil :**  
To avoid malfunction due to noise from the input and output lines, please insert an input and output normal mode choke coil.
  - **Input Fuse :**  
For safety reasons, please place a input fuse on the input of each module. Further, we recommend placing an apparatus input fuse on the input section.
  - **Wiring :**  
The standard is to wire short and thick. Especially, wire the output -V terminals short and thick.
- **Determining the Recommended External Component Values**

### **a) F1 : AC Input Fuse**

Please select a component that meets the following recommended conditions.

- **Standard Voltage**  
100VAC Input Series : AC125V  
200VAC Input Series : AC250V



- **Standard Current**  
 Please choose a component above  $N$  (paralleled units)  $\times$  the calculated input current of each PF-B module.  
 Further, for the standard current, please select the components so that  $F1 > F2$ .

- **Withstand Surge Current**  
 Please calculate the withstand surge current with the following formula.

$$I^2t = N^2 \times A(A^2s) \quad (\text{Formula 6-5})$$

- $I^2t$  : Withstand Surge Current needed for F1
- $N$  : Parallel Operation Units
- $A$  : Withstand Surge Current needed for F2 (refer to Formula 6-6)

Further, when calculating with the above conditions, the value will be on the large side compared to the actual measured value. Therefore, base your selection on the measured value for the withstand surge current.

**b) F2 : PF-B Input Fuse**

When the line from the PF-B series output to the PH/PT series is long, a input electrolytic capacitor is needed to stabilize the PH/PT series input voltage. Therefore, when inserting a input electrolytic capacitor, a surge current will be added to F2. Please consider the sum of the PF-B series output smoothing capacitors.

C13 and C14 with the following equation.

Further, C14 must be considered with all PF-B series modules in parallel operation.

$$A = \frac{(C_{13} + C_{14}) \times V_a^2}{2 \times r} \quad (A^2s) \quad (\text{Formula 6-6})$$

- $A$  : Withstand Surge Current needed for F2
- $C13$  : Output Smoothing Capacitor
- $C14$  : Secondary Input Electrolytic Capacitor (please consider the tolerance)
- $V_a$  : Input 200V Series  $V_{in-200}$   
           Input 100V Series  $V_{in}$   
           However,  $V_{in}$  is the maximum input voltage DC conversion value.
- $r$  : Input Line Impedance

**c) TRF1, TRF2 : Input Surge Current Protective Resistor**

For the input surge current protective resistor, the output smoothing capacitance must be considered in the same way as for the PF-B input fuse.

**d) L1 : Normal Mode Choke Coil**

Please select a input interference protective normal mode choke coil that meets the following conditions.

- **Recommended Inductance Value 10uH : 5~30uH**  
 Please select a similar component for the output interference protective normal mode chock coil L2.

**e) D1 : Output Diode**

Please select a output diode that meets the following conditions.

- Reverse Withstand Voltage : 600V or above.
- Standard Current  
 Allow a good margin vs. the output current of the PF-B that is being used and select the appropriate standard current output diode.
- Withstand Surge Current  
 The C14 charging current will flow to the output diode. On this occasion the withstand current will be as shown in the following equation.

$$I^2t = \frac{C_{14}^2 \times V_a^2}{2 \times r \times (C_{13} + C_{14})} \quad (A^2s) \quad (\text{Formula 6-7})$$

- $I^2t$  : Withstand Surge Current needed for D1
- C13 : Output Smoothing Capacitor
- C14 : Secondary Input Electrolytic Capacitor (please consider the tolerance)
- $V_a$  : Input 200V Series  $V_{in-200}$   
 Input 100V Series  $V_{in}$   
 However,  $V_{in}$  is the maximum input voltage DC conversion value.
- $r$  : Input Line Impedance

**f) F3 : Output Fuse**

F3 is the abbreviation in the case that an input fuse is connected to the DC-DC converters.

**g) C14 : DC-DC(PH/PT) Input Electrolytic Capacitor ( less than 100uF )**

When the wiring from the PF-B series to the PH/PT series is long and there is a large voltage drop and regulation, please place this capacitor to the input section of the PH/PT series.  
 Please select the capacitor so that the sum of C13 and C14 does not exceed the PF-B series maximum external output capacitance.  
 Further, ripple current will flow through this capacitor. Please check and select a component that satisfies the ripple current.

- Standard Voltage : Recommended voltage rating 450VDC.

● Signal Connection for Parallel Operation

The parallel operation signal connection for the PF-B series to the secondary PH/PT series is recommended as follows.

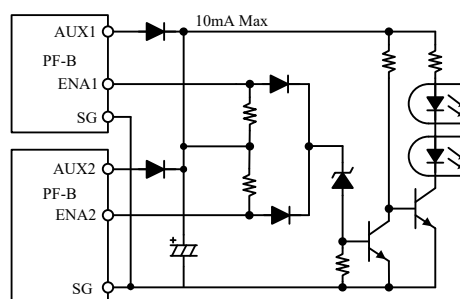

Fig.6-6 Signal Connection for Parallel Operation

Please select a electrolytic capacitor or 10 $\mu$ F or below for the capacitor connected to the AUX terminal. Further, 0.1 $\mu$ F capacitors have a good effect in removing noise between the ENA, IOG terminals and SG terminal.

Upon module power supply development, depending on the PCB to be loaded on and the construction, applications not mentioned above may be needed. Please confirm with the actual equipment being used.

### 6-19. Operating Ambient Temperature

There is no restriction on mounting direction but there should be enough consideration for airflow so that heat does not accumulate around the power supply vicinity.

Determine external components configuration and mounting direction on PCB such that air could flow through the heatsink at forced cooling and conduction cooling.

By maintaining actual ambient temperature below 85°C and base-plate temperature below 100°C, operation is possible. For details on thermal design, refer to Application Notes “Thermal Design”.

Note) 1. Maximum base-plate temperature is 100°C. For worst case operating condition, verify base-plate temperature at measurement point indicated in Fig. 6-7. Moreover, ambient air temperature shall be confirmed at a point 10 mm or less from the power supply side indicated in Fig. 6-8. Use below 85°C ambient temperature.

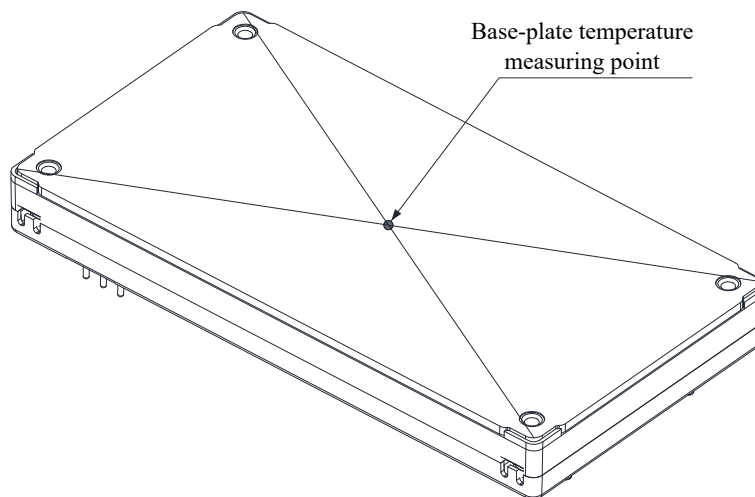

Fig.6-7 Base-plate measuring point

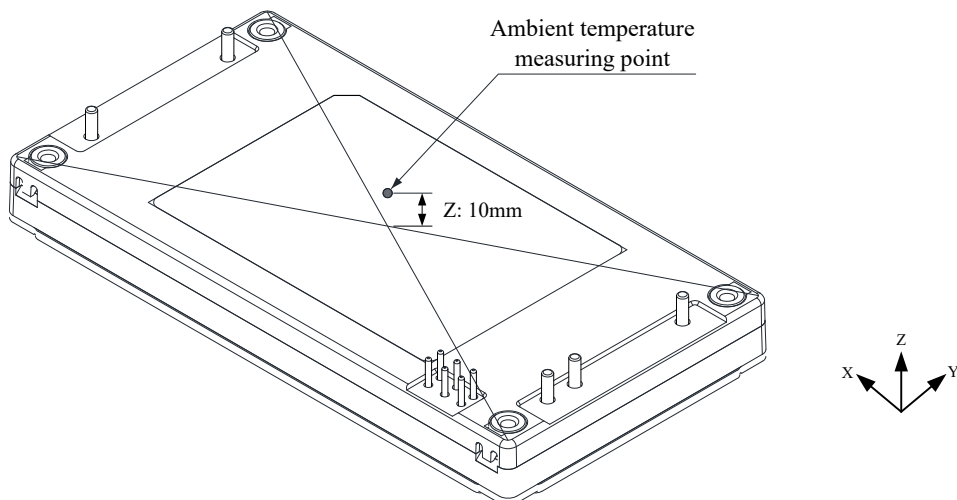

Fig.6-8 Ambient measuring point

Note) 2. There is limitation on input voltage range and baseplate temperature range for as shown in Fig.6-9.

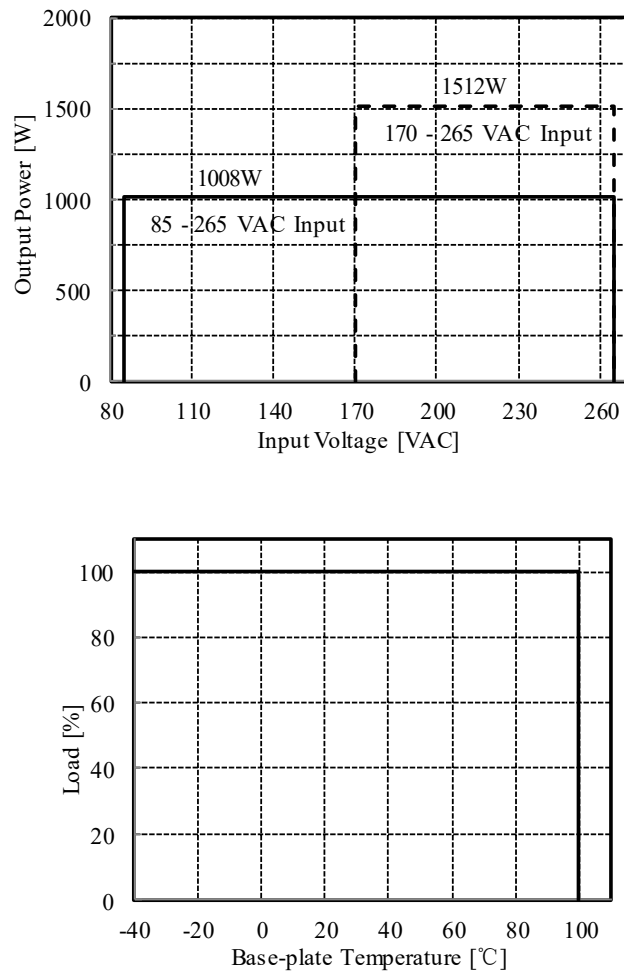

Fig.6-9 Derating Curve

To further improve reliability, it is recommended to use this power supply with ambient temperature and base-plate temperature derating.

#### 6-20. Operating Ambient Humidity

Take note that condensation could lead to power supply abnormal operation or damage.

#### 6-21. Storage Ambient Temperature

Take note that sudden temperature changes can cause condensation buildup, and other harmful affects to each terminal solder.

#### 6-22. Storage Ambient Humidity

Take enough care when storing the power module because rust which causes poor solderability would form in each terminal when stored in high temperature, high humidity environment.

#### 6-23. Cooling Method

Operating temperature range is specified by the base-plate temperature (limited to 100°C). Therefore, several methods of heat dissipation are possible.

For details on thermal design, refer to Application Notes “Thermal Design”.

### 6-24. Withstand Voltage Test

This power module is designed to have a withstand voltage of 2.5kVAC between terminals and base-plate for 1 minute.

When conducting withstand voltage test during incoming inspection, set the current limit value of the withstand voltage testing equipment to 10mA.

Furthermore, avoid throw in or shut off of the testing equipment when applying or when shutting down the test voltage. Instead, gradually increase or decrease the applied voltage. Take note especially not to use the timer of the test equipment because when the timer switches the applied voltage off, impulse voltage which has several times the magnitude of the applied voltage is generated causing damage to the power supply.

Connect the terminals as shown in the diagram below.

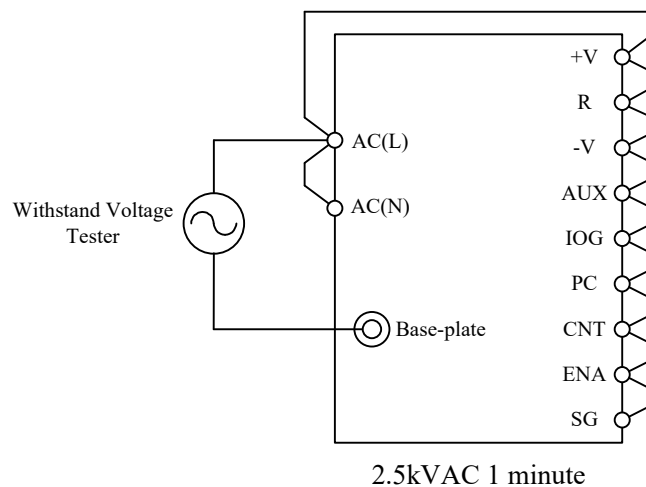

Fig.6-10 Withstand Voltage Test for Input and Output terminals – Base plate

### 6-25. Isolation Resistance

Use DC isolation tester (MAX 500V) between output and base-plate and input and base-plate. Isolation resistance value is 100MΩ and above at 500VDC applied voltage. Make sure that during testing, the isolation testers do not generate a high pulse when the applied voltage is varied. Ensure that the tester is fully discharged after the test.

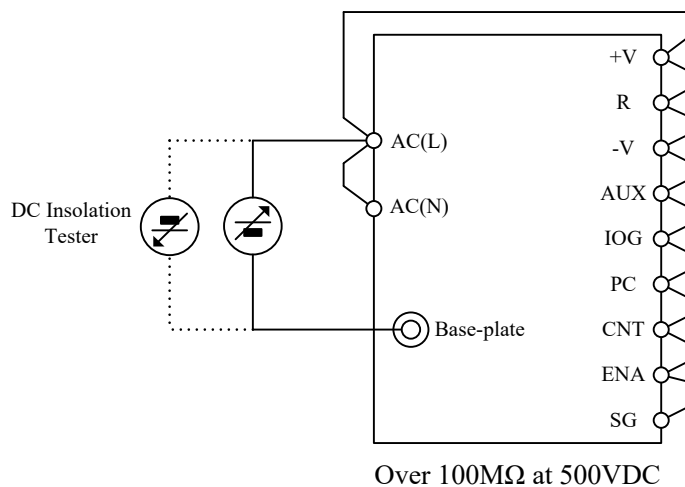

Fig.6-11 Insolation Resistance test

**6-26. Vibration**

Vibration of power supply is defined when mounted on printed circuit board.  
 For details, refer to “7. Mounting Method”.

**6-27. Shock**

Withstand shock value is defined to be the value at TDK -Lambda shipment and packaging conditions, or when mounted on printed circuit board.

When mounting on printed circuit board, refer to “7. Mounting Method”.

**7. Mounting Method**

This products can be used in any orientation but be sure to consider enough airflow to avoid heat accumulation around the power supply. Consider surrounding components layout and set the PCB mounting direction such that air can flow through the heat sink by forced or convection cooling. This product can operate at actual mounting condition when baseplate temperature and ambient temperature are maintained at or below the following temperature.

$$T_a = 85^{\circ}\text{C} , T_{\text{base-plate}} = 100^{\circ}\text{C}$$

**7-1. Mounting Method**

By the following instruction shown in Fig. 7-1 for (a)Standard Mounting Method and (b)/T option Mounting Method, mount power supply onto printed circuit board.

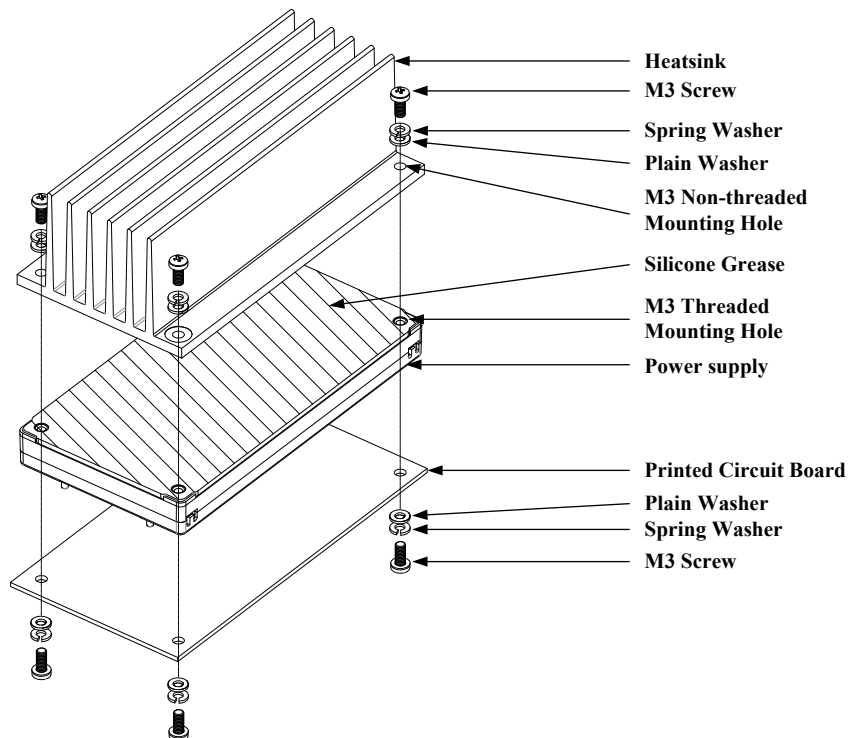

Fig.7-1 Mounting Method (a): Standard Mounting Method

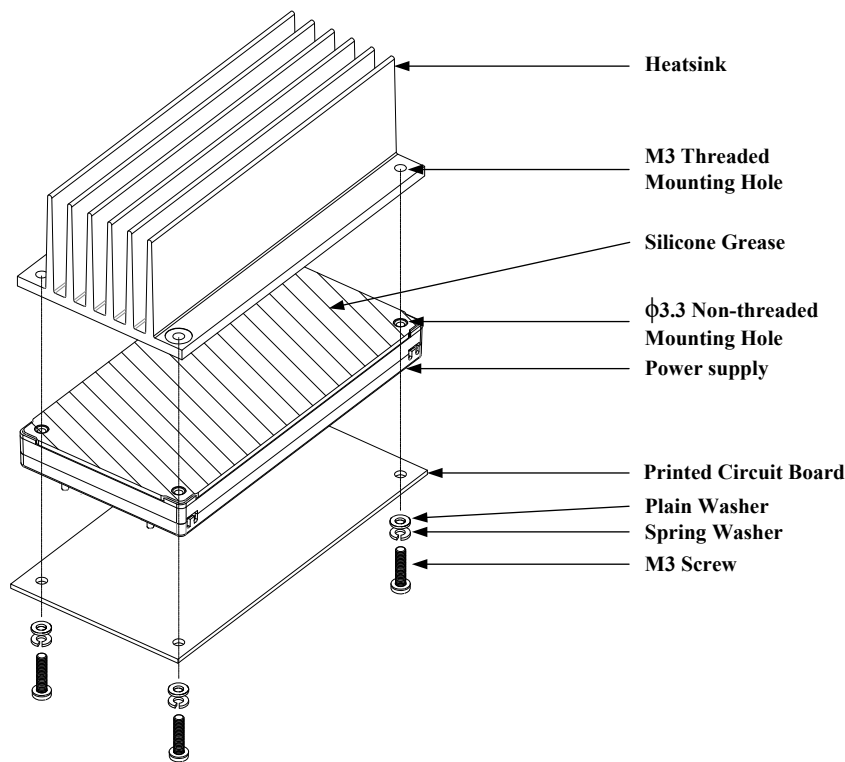

Fig.7-1 Mounting Method (b): /T option Mounting Method

(1) Method to Fixing on Printed Circuit Board

To fix a power module onto printed circuit board, use M3 screws and mount it to the M3 threaded holes of the power module. Recommended torque is 0.54N·m.

(2) Mounting Holes (/T option is φ3.3 non-thread)

Mounting holes of the power supply are connected to base-plate. Connect base-plate to FG (Frame Ground) by using this mounting holes.

(3) Mounting Holes on Printed Circuit Board

Refer to the following sizes when determining diameter of hole and land diameter of printed circuit board.

Input /Output terminals (φ2.0 mm )

Hole diameter : φ2.5 mm

Land diameter : φ4.6 mm

Signal terminals (φ1.0 mm )

Hole diameter : φ1.5 mm

Land diameter : φ2.4 mm

Mounting Holes (FG)

Hole diameter : φ3.5 mm

Land diameter : φ6.0 mm

For position of the holes, see outline drawing of the power supply.

(4) Recommended Material of PCB

Recommended materials of the printed circuit board is double sided glass epoxy with through holes. (thickness t:1.6mm , copper 35μm or more)

#### (5) Input / Output Pattern Width

Large current flows through input and output pattern. If pattern width is too narrow, heat on pattern will increase because of voltage drop of pattern. Relationship between allowable current and pattern width varies depending on materials of printed circuit board, thickness of conductor. It is definitely necessary to confirm on manufacturers of printed circuit board for designing pattern.

#### (6) Method of Connecting Terminals

Connect AC(L), AC(N), +V, -V, R with consideration of contact resistance .

### 7-2. Heatsink Installation Method

#### (1) Method of Fixing Heatsink

##### (1-1) Standard model

To fix the heatsink onto power module, use M3 screws and mount it to the M3 threaded holes (2 places) at the base-plate side. Recommended torque is 0.54 N·m.

##### (1-2) /T option model

To fix the heatsink onto power module, use M3 screws those are the same screws for mounting power module onto printed circuit board.

Use silicone grease or thermal conductive sheet in between heatsink and base-plate to minimize the contact thermal resistance and to enhance the heat conductivity.

Also use the no-warped heatsink and make sure good contact between base-plate and heatsink.

#### (2) Mounting Hole of Heatsink

Recommended mounting hole is as follows.

(2-1) Standard model     $\phi 3.5$  Non-threaded hole

(2-2) /T option model    M3 Threaded hole

### 7-3. Regarding Vibration

The vibration specification of the power supply is determined assuming that only the power supply is mounted on printed circuit board. To prevent excessive force to the power supply and the printed circuit board, fix the heatsink to the chassis as well as to the power supply when a large size of heatsink is used.

### 7-4. Recommended Soldering Condition

Recommended soldering conditions are as follows.

#### (1) Soldering dip

Dip condition : 260°C within 10 seconds

Pre-heat condition : 110°C for 30 - 40 seconds

#### (2) Soldering iron

350°C within 3 seconds

Note) Soldering time changes according to heat capacity of soldering iron, pattern on printed circuit board, etc. Please confirm actual performance.

### 7-5. Recommended Cleaning Condition

Recommended cleaning condition after soldering is as follows.

#### (1) Cleaning solvent

IPA (isopropyl alcohol )

#### (2) Cleaning Procedure

Use brush and dry the solvent completely.



## 8. Before Concluding Power Module Damage

Verify following items before concluding power supply damage.

(1) No output voltage

- Is specified input voltage applied?
- Are the ON/OFF control terminal (CNT) correctly connected?
- For cases where output voltage adjustment is used, is the resistor or variable resistor setting, connections correctly done?
- Are there no abnormalities in the output load used?
- Is the base-plate temperature within the specified temperature range?
- Is the room temperature within the specified temperature range?

(2) Output voltage is high

- Is the measurement done at the sensing points?
- Are there no abnormalities in the output load used?

(3) Output voltage is low

- Is specified input voltage applied?
- Is the measurement done at the sensing points?
- Are there no abnormalities in the output load used?

(4) Load regulation and line regulation is large

- Is specified input voltage applied?
- Are the input terminals and the output terminals firmly connected?
- Is the measurement done at the sensing points?
- Is the input or output wire too thin?

(5) Output ripple voltage is large

- Is the measurement done according to methods described in the Instruction Manual or is it an equivalent method?
- Is the input ripple voltage value within the specified value?

## 9. Warranty Period

Warranty period is 5 years.

For damages occurring at normal operation within this warranty period, repair is free of charge.

Following cases are not covered by warranty

- (1) Improper usage like dropping products, applying shock and defects from operation exceeding specification of the unit.
- (2) Defects resulting from natural disaster (fire, flood etc.)
- (3) Unauthorized modifications or repair by the buyers' defects not cause by our company.

## 10. CE Marking/UKCA Marking

### CE Marking

CE Marking, when applied to a product or packing material for a product covered by this handbook, indicates compliance with the Low Voltage Directive, EMC Directive and RoHS Directive.

### UKCA Marking

UKCA Marking, when applied to a product or packing material for a product covered by this handbook, indicates compliance with the Electrical Equipment (Safety) Regulations, Electromagnetic Compatibility Regulations and Restriction of the Use of Certain Hazardous Substances in Electrical & Electronic Equipment Regulations.