

# PFE1500 Series Instruction Manual

- **BEFORE USING THE POWER SUPPLY UNIT:**

Be sure to read and understand this instruction manual thoroughly before using this product. Pay attention to all cautions, warnings, and safety notes before using this product. Incorrect usage could lead to an electrical shock, injury, damage to the unit or a fire hazard.

- The information in this document is subject to change without prior notice. Please refer to the latest version of the data sheet, etc., for the most up-to-date specifications of the product.
- No part of this document may be copied or reproduced in any form without prior written consent of TDK-Lambda.



## Contents

• <b>BEFORE USING THE POWER SUPPLY UNIT:</b> .....	1
1 Model Name Identification Scheme.....	4
1.1 Ordering Table .....	4
2 Module Pinout (Pin Side-Up).....	5
3 Circuit Block Diagram .....	6
4 Sequence Timing Diagram .....	7
5 Bus Transition Diagram .....	8
6 Start-up Timing Diagram.....	9
7 Terminal Connecting Method.....	10
7.1 F1 External Input Fuse .....	11
7.2 C2 (0.47 $\mu$ F); C3 (3.94 $\mu$ F) Film Capacitor or Class X Safety Capacitor .....	11
7.3 L1 (1.0 mH); L2 (1.3 mH) Common Mode Choke .....	12
7.4 C4 (4700 pF); C5 (4700 pF); C6 (4700 pF); C7 (4700 pF) Ceramic Capacitor or Class Y Capacitor .....	12
7.5 L3 (27 $\mu$ H); L4 (27 $\mu$ H) Inductor .....	12
7.6 R1 (470 k $\Omega$ , 2 W); R4 (470 k $\Omega$ , 2 W); R5 (470 k $\Omega$ , 2 W) .....	12
7.7 C16 (7500 pF); C17 (7500 pF) Ceramic Capacitor or Class Y Capacitor .....	12
7.8 Electrolytic Bulk Capacitors: C8 (470 $\mu$ F); C9 (470 $\mu$ F); C10 (470 $\mu$ F); C11 (470 $\mu$ F) .....	12
7.9 C15 (0.1 $\mu$ F, 50 V~100 V Ceramic Capacitor) .....	13
7.10 C14 (37.6 $\mu$ F, 50 V~100 V or (8) 4.7 $\mu$ F Ceramic capacitors in parallel) .....	13
7.11 C12; C13 – Output Electrolytic Capacitors .....	14
7.12 R2 (10.0 $\Omega$ ); R3 (10.0 $\Omega$ ) .....	15
7.13 RL Inrush Relay (12 V Coil, 10 A / 277 Vac; 16 A / 125 Vac) .....	16
8 Explanation of Functions and Precautions .....	16
8.1 Input Voltage Range .....	16
8.2 Output Grounding Scheme .....	16
8.3 Output Voltage Adjustment Range .....	16
8.4 Inrush Current .....	19
8.5 High-Voltage Bus (or VBUS) Over Voltage and Under Voltage Protection .....	19
8.6 Output Over Voltage and Under Voltage Protection .....	19
8.7 Input Over Voltage and Under Voltage Protection .....	19
8.8 Output Current Rating .....	19
8.9 Over Current Protection (OCP) .....	21

8.10	Constant-Current Voltage Foldback	21
8.11	Auto-Recovery Mode Option (Non-Latching)	22
8.12	Over Temperature Protection (OTP)	22
8.13	Remote Sensing	22
8.14	ON-OFF Control	23
8.15	Power Good Signal (PGood)	24
8.16	Auxiliary Bias Power	24
8.17	Droop Load Share (Parallel Operation)	24
8.18	Series Operation	26
8.19	PMBus Communication	27
8.20	Ripple and Noise	28
8.21	Withstand Voltage Test (Hipot Test)	29
9	Thermal Considerations and Mounting Method.....	31
9.1	Thermal Consideration	31
9.2	Thermal Test Setup	32
9.3	Output Current / Case Temperature Thermal Derating	32
9.4	Recommended Soldering Condition	33
9.5	Recommended Washing Condition	33
10	Warranty Period.....	34
11	Appendix.....	35
11.1	EMI Conducted Emissions CISPR 32:2015 Class A Recommended Values	35
12	Document History .....	37

## 1 Model Name Identification Scheme

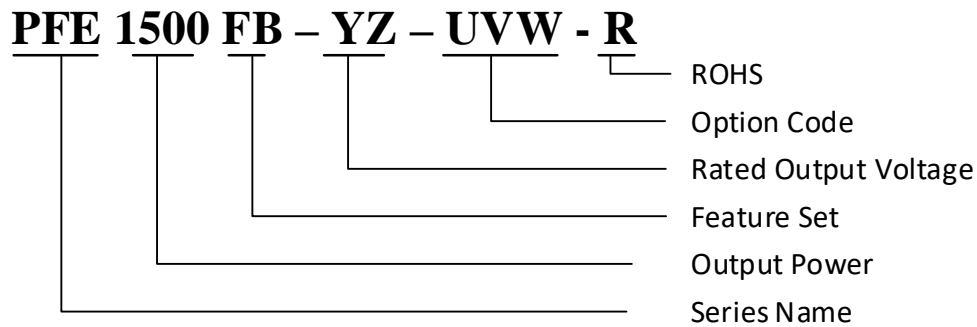

### 1.1 Ordering Table

<b>FB</b>	<b>YZ</b>	<b>U</b>	<b>V</b>	<b>W</b>			<b>Pin Length</b>
<b>Feature Set</b>	<b>Output Voltage</b>	<b>Case Mounting Holes</b>	<b>Output Operation</b>	<b>OVP (Default)</b>	<b>OCP (Default)</b>	<b>OTP (Default)</b>	
<b>FB</b> : Full Featured	<b>28</b> : 28 Vdc <b>48</b> : 48 Vdc	<b>0</b> : Thru-Hole <b>1</b> : Threaded	<b>0</b> : Standard	Latching	Non-Latching	Non-Latching	0.260"

## 2 Module Pinout (Pin Side-Up)



PIN #	PIN DESIGNATION	FUNCTION	PIN #	PIN DESIGNATION	FUNCTION
1	AC (L)	AC Input - Live Line	13	PMBus Address 2	Address Lines
2	AC (N)	AC Input - Neutral Line	14	PMBus Address 1	Address Lines
3	Vout(-)	-Output Voltage (Return)	15	Trim	Output Voltage Adjust
4	Vout(-)	-Output Voltage (Return)	16	On/Off	Output On/Off Pin
5	Vout(-)	-Output Voltage (Return)	17	SGND	Secondary Signal Ground
6	RS(+)	+Remote Sense Line	18	PGood	Power Good
7	Vout(+)	+Output Voltage	19	Aux Pwr	Auxiliary Supply Output
8	Vout(+)	+Output Voltage	20	Inrush Control	Inrush Control pin
9	Vout(+)	+Output Voltage	21	Reserved	do not connect
10	PMBus Clock	I2C Clock	22	Reserved	do not connect
11	PMBus Data	I2C Data	23	-VBUS	-Boost Voltage
12	PMBus Alert	Alert Line	24	+VBUS	+Boost Voltage

**NOTE:**

- Module case can be connected to Earth Ground through the mounting holes. Care should be taken to evaluate as this has potential to degrade effectiveness of the EMI filter.
- +VBUS and -VBUS terminals are primary voltage with high voltage rating (460 Vdc).
- Do not connect any external load(s) across +VBUS and -VBUS terminals. Otherwise, it may damage the module.

### 3 Circuit Block Diagram

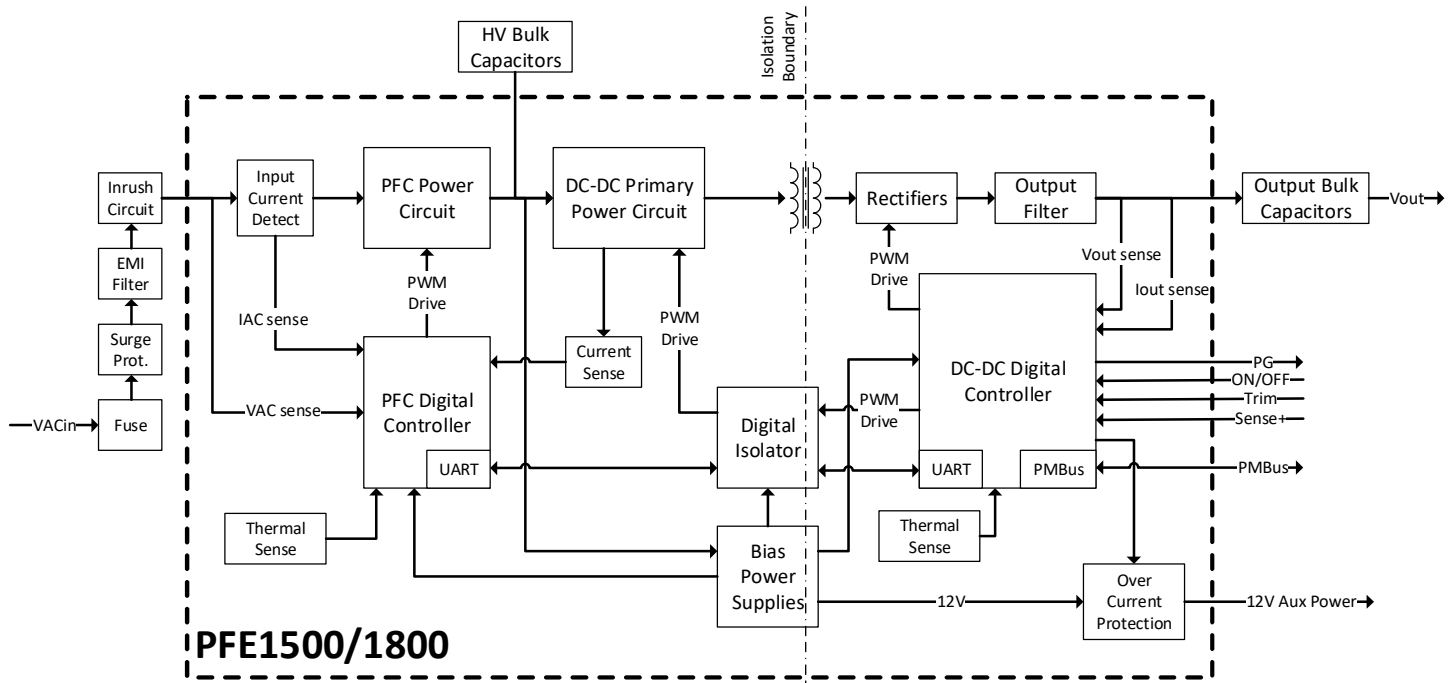

**NOTE:** Blocks outside PFE1500 (heavy dotted line) and additional support components are required for operation.

SWITCHING FREQUENCY		
PFC Converter (Fixed)	200 kHz	400 kHz (Ripple frequency)
DC-DC Converter (Fixed)		
$V_o = 28$ Vdc	200 kHz (Primary)	400 kHz (Secondary Ripple)
$V_o = 48$ Vdc	200 kHz (Primary)	400 kHz (Secondary Ripple)
BIAS Converter	112 kHz	

## 4 Sequence Timing Diagram

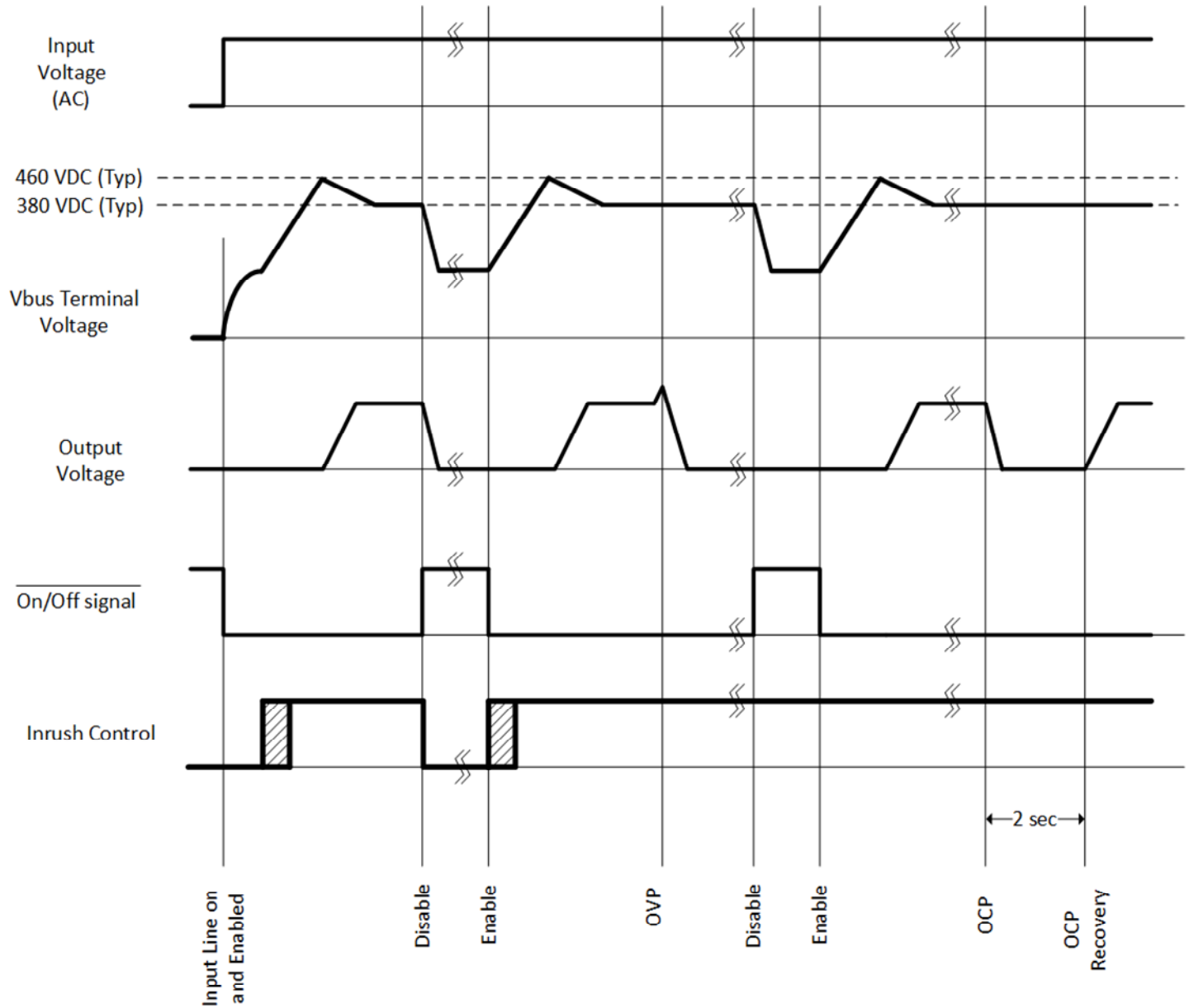

### NOTE:

- Input voltage (AC) remains below 262Vrms for this timing diagram.
- PFE1500/1800 Series product has a remote ON/OFF (Pin 16) that is referenced to SGND (Pin 17).

## 5 Bus Transition Diagram

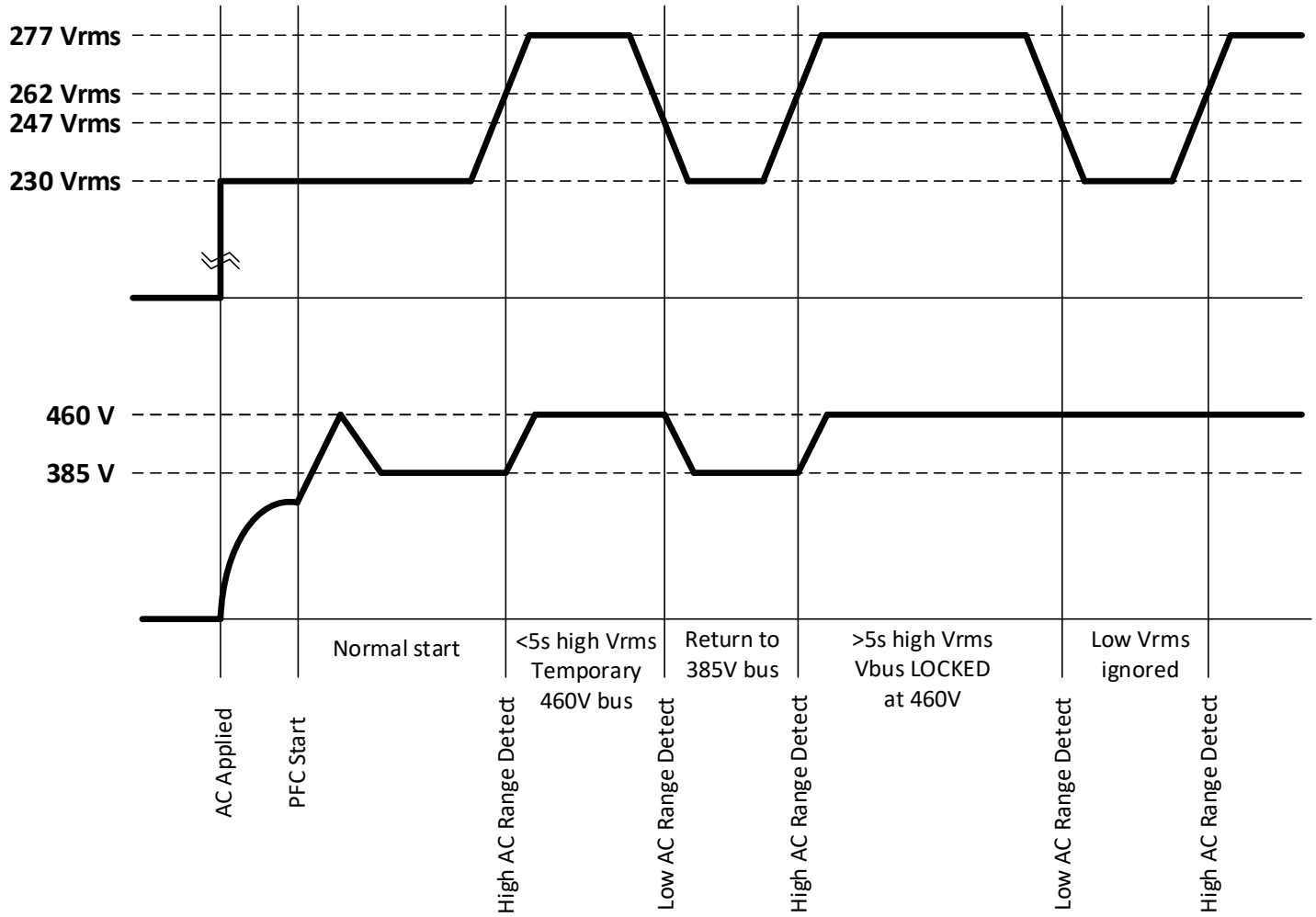

**NOTE:**

- To reset 460V bus lock, a power-cycle must be performed (input power must be removed and module fully discharged)

## 6 Start-up Timing Diagram

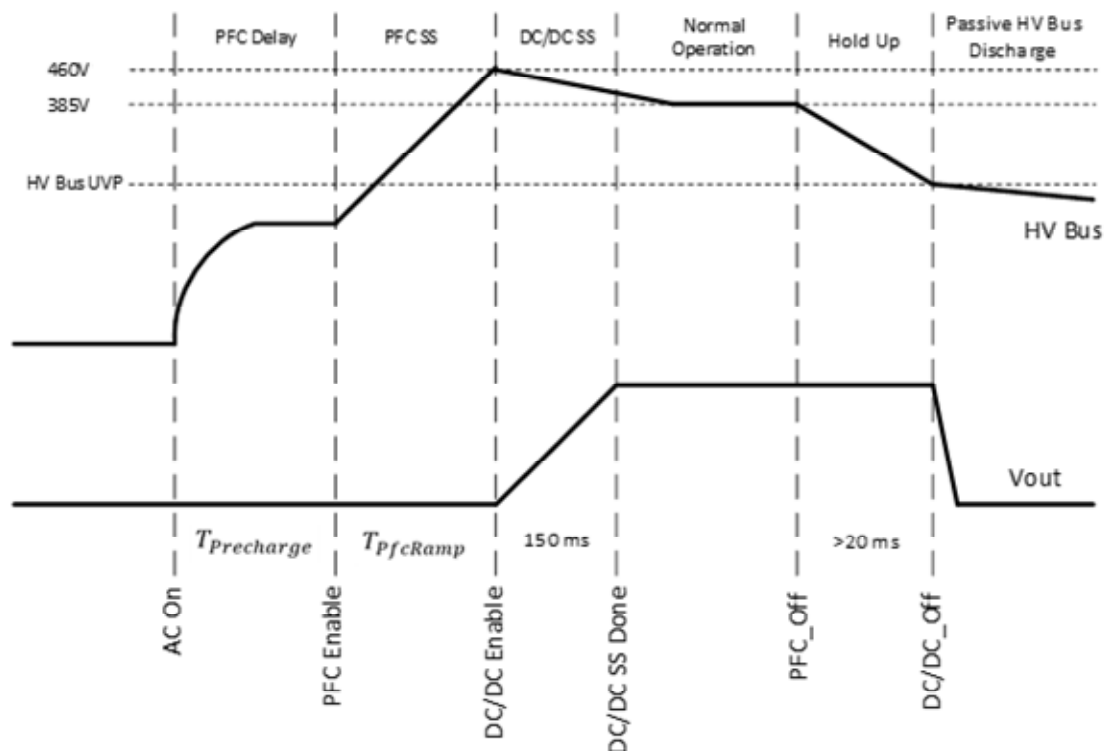

### NOTE:

- Input voltage (AC) remains below 262Vrms for this timing diagram.
- ON pin asserted.
- PFE1500/1800 Series product has a remote ON/OFF (Pin 16) that is referenced to SGND (Pin 17).

Time (seconds)	115VAC	230VAC	277VAC
$T_{Precharge}$	1.0	0.8	0.8
$T_{PfcRamp}$	1.2	0.5	0.3
$T_{Total}$	2.2	1.3	1.1

### NOTE:

- 60Hz, 20Ω in-rush resistor
- Times are typical

## 7 Terminal Connecting Method

For proper operation, the PFE1500/1800 series module must be connected with the external components shown in Figure 7-1. Pay attention to the wiring details. If the PFE module is wired incorrectly, the power module may be damaged.

The PFE Series module is designed for use in both convection and conduction cooling applications. For more details refer to thermal considerations, section 9 of this document.

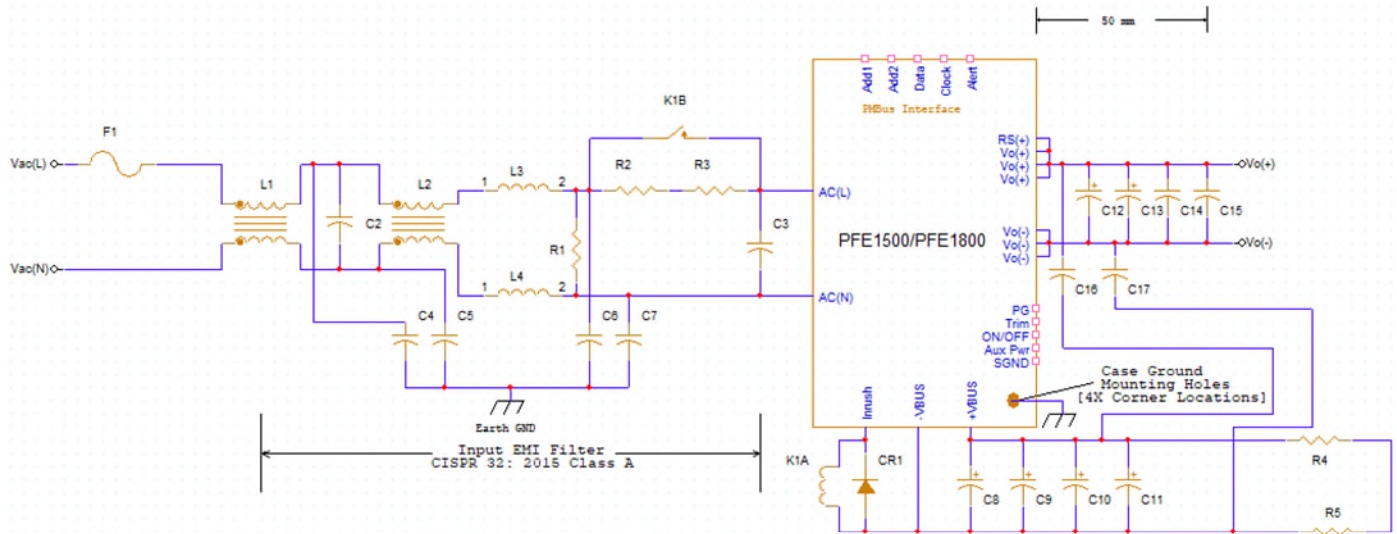

Fig. 7-1 Basic Connection

## 7.1 F1 External Input Fuse

The PFE1500/1800 series module has no internal fuse. An external fuse is required to meet Safety Agency requirements.

PFE1500/1800 series modules were tested for safety agency certifications using a maximum 20A, 280 Vac, Fast-Acting line fuse. One Fast-Acting type fuse must be used for each PFE module.

When selecting a fuse, be aware the line inrush surge current will flow through the PFE module and the fuse during initial line power application (or line power switch in). Check that the I<sup>2</sup>t rating of the external line fuse is sufficient.

Recommended External Fuse: **20 A, 280 V (Fast Acting)**

Note: Select fuse based on rated voltage, rated current and surge current capability.

### (1) Voltage Ratings

115 Vac line : AC125V  
 230 Vac line : AC250V  
 277 Vac line : AC305V

### (2) Current Ratings

Rated current is determined by calculating the maximum input current based on operating conditions using the following formula:

$$I_{in} \text{ (max)} = \frac{P_{out}}{V_{in} \text{ (min)} \times \eta \times PF} \text{ (Arms)} \quad \text{(Formula 7-1)}$$

I<sub>in</sub> (max) : Maximum Input Current  
 P<sub>out</sub> : Maximum Output Power  
 V<sub>in</sub> (min) : Minimum Input Voltage  
 η : Efficiency  
 PF : Power Factor

For Efficiency and Power Factor values, refer to separate document "PFE1500 Series Evaluation Data".

## 7.2 C2 (0.47 μF); C3 (3.94 μF) Film Capacitor or Class X Safety Capacitor

These capacitors are connected across the AC power line to reduce differential mode interference. Since the X capacitors are connected across the line and neutral, the ripple current flowing through these capacitors can be high. When selecting X capacitors, be sure to check the allowable maximum ripple current ratings.

TDK-Lambda Americas recommends customers verify the actual ripple current flowing through each X capacitor by measuring the current flow. (typically C2 should be rated for 180 mA rms harmonic current or higher, C3 for 1.2 A rms harmonic current or higher)

Connect C3 as close to the input terminals of PFE1500 series power module [i.e. AC(L) and AC(N)] as possible.

Recommended Voltage Rating of X - Capacitors: 115 - 230 Vac range 275 Vac or greater.  
 277 Vac range 330 Vac or greater.

### **7.3 L1 (1.0 mH); L2 (1.3 mH) Common Mode Choke**

Add recommended common mode chokes to reduce EMI noise. When using multiple PFE1500 series modules in parallel, it is important to provide EMI filtering (including X caps, Y caps, and common mode chokes) for each PFE1500 module.

### **7.4 C4 (4700 pF); C5 (4700 pF); C6 (4700 pF); C7 (4700 pF) Ceramic Capacitor or Class Y Capacitor**

Y-capacitors are used to reduce common mode noise. The leakage current requirement of the end equipment or instrument should be considered when finalizing the value of these capacitors.

### **7.5 L3 (27uH); L4 (27uH) Inductor**

Add recommended differential mode inductors to reduce EMI noise.

### **7.6 R1 (470 k $\Omega$ , 2 W); R4 (470 k $\Omega$ , 2 W); R5 (470 k $\Omega$ , 2 W)**

Connect bleeder resistors, R1, across the AC input terminals and R4 and R5 in series across the bulk capacitors C8 - C11 as shown in Fig. 7-1.

### **7.7 C16 (7500 pF); C17 (7500 pF) Ceramic Capacitor or Class Y Capacitor**

Y-capacitors cross the dc-dc converter isolation boundary and are used to reduce common mode noise. These capacitors should be connected between the points indicated in figure 7-1 with low inductance traces that are as short as possible. Capacitors with a high voltage rating are typically required for safety isolation withstanding purposes. High test voltages are often applied across these capacitors during production hipot testing.

### **7.8 Electrolytic Bulk Capacitors: C8 (470 $\mu$ F); C9 (470 $\mu$ F); C10 (470 $\mu$ F); C11 (470 $\mu$ F)**

Recommended Voltage Rating: 500 Vdc (105 °C rated capacitor)

Recommended Capacitance: 4 x 470  $\mu$ F

Notes:

1. Connecting capacitors with a different capacitance value than mentioned has potential to degrade performance or result in the PFE Series power module or the capacitors being damaged. Consult TDK-Lambda for different bulk capacitor requirements.
2. When using the PFE power modules below room ambient temperature, both the AC ripple of VBUS and the output ripple voltage might be affected by ESR characteristics of the bulk capacitors. Performance characteristics over temperature should be confirmed by evaluation in the end application.
3. Bleeder resistors, R4 & R5 (470 k $\Omega$  / 2 W), must be connected across C8, C9, C10 or C11 to discharge the bulk capacitor voltage to a safe level after powering off the PFE module. Refer to Figure 7-1.
4. Do not connect any external load to the Bulk Capacitors or the module may be damaged.

**Selection Method of External Bulk Capacitor for VBUS**

C8, C9, C10, & C11 capacitor values affect the module’s output hold-up time, dynamic line transient response, and dynamic load transient response characteristics. Use of good quality capacitors with high ripple current ratings is highly recommended.

The ripple current should be verified in the application considering the desired capacitor’s lifetime, and performance. The PFE power module design features internal MLCC capacitors to help reduce electrical stress on the external bulk capacitors. Typical ripple current magnitude versus output power is provided in Figure 7-2.

When the ambient temperature is reduced, the ripple voltage of C8, C9, C10, C11 will increase due to ESR characteristics. It is recommended to verify characteristics by evaluation in the circuit at the minimum operating temperature.

Per the sequence timing diagram, the voltage across these capacitors typically reaches 460Vdc during the startup sequence. Capacitors that can operate reliably at this voltage level should be selected. Depending upon the application use case, lower voltage capacitors with guaranteed surge ratings can be considered if deemed appropriate.

For output hold-up time, refer to separate document “PFE1500 Series Evaluation Data”, and use an appropriate capacitor based on the application requirements. It is recommended that actual verification testing be performed.

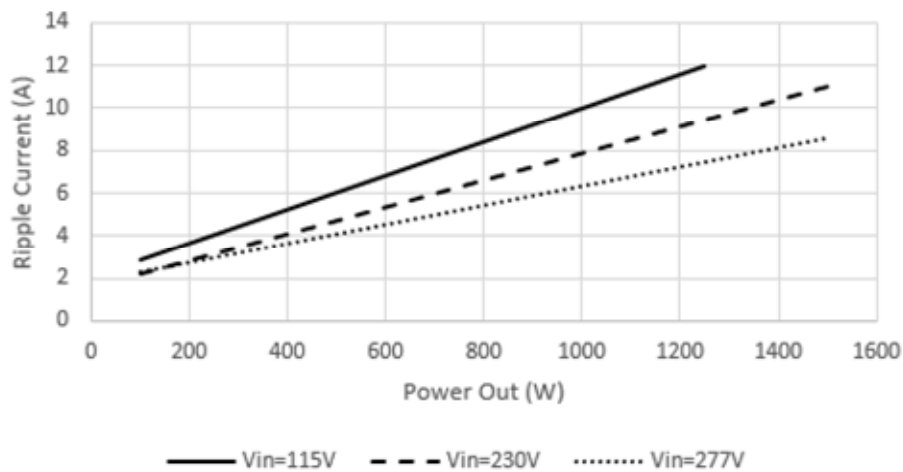

*Fig. 7-2 Typical Bulk Capacitor Ripple Current*

**7.9 C15 (0.1 μF, 50 V~100 V Ceramic Capacitor)**

Add this output ceramic capacitor approximately 50 mm away from the PFE Series module output terminals to help reduce high frequency output noise.

**7.10 C14 (37.6μF, 50 V~100 V or (8) 4.7 μF Ceramic capacitors in parallel)**

Add these output ceramic capacitors approximately 50 mm away from the PFE Series module output terminals to help reduce the high frequency output ripple noise and improve the load transient response.

## 7.11 C12; C13 – Output Electrolytic Capacitors

Connect C12 and C13 near the output terminals Vo(+) and Vo(-) of the PFE Series power module to stabilize the module operation and improve transient response. The output ripple and dynamic characteristics of the power module are affected by the ESR and ESL values of the output electrolytic capacitors and may also vary depending on the physical location and the layout of the printed circuit board. Verification of performance in the end application is recommended.

*Table 7-1 Minimum External Output Capacitance for C12, C13*

Module Output Voltage	C12	C13
28 V	560 $\mu$ F, 50 V	560 $\mu$ F, 50 V
48 V	560 $\mu$ F, 100 V	560 $\mu$ F, 100 V

Notes:

- (1) Higher external output capacitance values, beyond the minimum can help improve magnitude of the transient response due to changes in line voltage and/or load current. Contact TDK-Lambda for technical support if the application requires capacitance above 10,000 $\mu$ F.
- (2) Rubycon ZLJ series capacitors were used during the design evaluation testing process.
- (3) Use low-impedance electrolytic capacitors with excellent temperature characteristics rated at least to 105 °C.
- (4) When using the PFE power modules below room ambient temperature, the output ripple voltage might be affected by ESR characteristics of the bulk capacitors. Performance characteristics over temperature should be confirmed by evaluation in the end application.
- (5) Take note of the maximum allowable ripple current of the electrolytic capacitors being used. Verify the actual ripple current and make sure that allowable maximum ripple current of the external capacitor is not being exceeded.
- (6) If large output load steps are performed on the PFE module, it is recommended that the output capacitance be increased, but the value should not exceed the maximum capacitance value listed in the product data sheet.

## 7.12 R2 (10.0Ω); R3 (10.0Ω)

Wire wound, thermal fused inrush resistors should be inserted between the line filter and the input terminal, AC(L) as shown in Fig. 7-1, to limit the inrush current to a pre-determined level. Proper inrush control is required during turn-on to avoid the possibility of the external line fuse being blown, the input circuit breaker from being tripped, the bulk capacitors and/or PFE Series module internal parts from being damaged, and to prevent oscillation between the input inductor and the bulk capacitors.

For 50 / 60 Hz operation, the resistance value for R2 and R3 together is 20 Ω. Two 10 Ω / 5.0 W ceramic wire wound, thermal fused inrush resistors were used during evaluation testing. For 400 Hz operation, the suggested resistance value for R2 and R3 together is 9.4 Ω (2x 4.7Ω).

Note:

- (1) PFE1500 series module will not operate if the external inrush resistor is not present.
- (2) For 50 / 60 Hz operation two 10.0 Ω / 5 W in series are typically used (Vishay, Part#: AC050000A1009J6BCS )
- (3) For 400 Hz operation, two 4.7 Ω / 5 W resistors in series are typically used (TT ELECTRONICS, Part #: ULW5-4R7JT075)

### External Resistor Selection Method

- (1) Calculating Resistance Values for R2 and R3:

Resistance can be calculated by the formula below.

$$(R2 + R3) = \frac{V_{in\_pk}}{I_{rush}} \quad (\Omega) \quad \text{(Formula 7-2)}$$

- (R2+R3) : Minimum Total Resistance Value Required for External Thermal Resistors, R2 and R3
- V<sub>in\_pk</sub> : Maximum Input Voltage Peak Value = Maximum Input Voltage (rms) x √2
- I<sub>rush</sub> : Allowed Input Inrush Current Peak Value during Initial Power Switch ON

- (2) Required Surge Current Rating:

Sufficient surge current withstanding capability is required for the external thermal resistors. The required Surge Current Rating of the resistors can be determined by I<sup>2</sup>t. (Current squared multiplied by time)

$$I^2t = \frac{C_b \times (V_{in\_pk})^2}{2 \times (R2 + R3)} \quad (A^2s) \quad \text{(Formula 7-3)}$$

- I<sup>2</sup>t : Thermal Resistor current-squared multiplied by time rating
- C<sub>b</sub> : Maximum Boost Output Bulk Capacitance
- V<sub>in\_pk</sub> : Maximum Input Voltage Peak Value = Maximum Input Voltage (rms) x √2
- R2 + R3 : Total Resistance Value for External Thermal Resistors, R2 and R3, Chosen

### 7.13 RL Inrush Relay (12 V Coil, 10 A / 277 Vac; 16 A / 125 Vac)

An inrush relay is connected in parallel with R2 and R3 resistors. The PFE module uses the inrush control pin to manage the energization of the relay to mitigate any secondary inrush current events during the relay closure. It is important to make sure that the relay contacts are open before applying AC power. Otherwise, an inrush current surge may damage the PFE Series module. Freewheeling diode CR1 is added across the coil to prevent voltage spikes during de-energization.

The inrush relay chosen must have a maximum switching voltage more than the input line range. A relay with minimum of 10 A / 277 Vac, 16 A / 125 Vac rating, and a 12 V / (15 to 20 mA) nominal coil operating voltage and current is recommended.

**Note:**

- (1) Panasonic relay (JVN1A-12V-F) was used for testing during the PFE development process.

## 8 Explanation of Functions and Precautions

### 8.1 Input Voltage Range

#### PFE1500F Series (50/60 Hz)

Input AC voltage source should be within 85-305 Vac RMS (47-63 Hz). Connecting the PFE Series module to any power source outside of this specified range may prevent the module from starting.

PFE1500F series power module is certified by various safety agencies with a certified label rating indicating: **100-277 Vac, 50-60 Hz, 14 A.**

#### PFE1500F Series (400 Hz)

Input AC voltage source must be within 85-140 Vac RMS (400 Hz nominal). Connecting the PFE Series module to any power source outside of the recommended range may prevent the module from starting. The PFE1500F modules have been evaluated against a wide range of voltage and frequency transients in accordance with MIL-STD-704 for 115V single-phase 400Hz equipment per MIL-HDBK-704-2 and single-phase variable frequency 115V equipment up to 800Hz per MIL-HDBK-704-4. Please contact TDK-Lambda support for more details on typical performance and to determine acceptability for utilization equipment.

### 8.2 Output Grounding Scheme

Vo (-) and SGND are two separate grounds tied internally within the PFE Series module. The Vo (-) and SGND pins should not be connected together at any point outside of PFE Series module.

Vo (-) is a power ground pin used as the return path for output load current and voltage connections, while SGND is used as the return path for logic signals (PMBus connection, Power Good, Trim, ON / OFF, and Aux Power). The SGND pin is a local ground reference and should not be routed and connected to the SGND of other PFE modules.

### 8.3 Output Voltage Adjustment Range

The output voltage of the PFE Series module can be adjusted up or down by connecting a trim resistor between the Trim pin and RS(+) pin or Vout(-) pin. For 48V outputs, the output voltage adjustment range is  $\pm 20\%$  of the nominal output voltage setting. For 28V outputs, the output voltage adjustment range is -20%, +30% of the nominal output voltage setting. Care must be taken to avoid attempting to trim the voltage outside the rated voltage range.

The PFE1500 will self-limit the output current when trimming up the output voltage. When trimming the module up, the maximum output power rating of the module is not increased and should be observed. Operating beyond the specified output power ratings may activate constant-current voltage foldback or OCP hiccup, depending on the output overcurrent mode selected.

The trim-up and the trim-down connections using external resistors are shown in Fig. 8-2, and Figure 8-4.

**NOTE:** To reduce noise, an external 0.1  $\mu$ F capacitor should be placed between the Trim and SGND pins.

By default, the trim pin and external set resistor controls the output voltage trim. In addition, the PFE1500 output voltage can also be adjusted using the module's PMBus interface. If the output voltage is adjusted using PMBus, the digital trim setting will override the resistor set analog trim. To revert back to the analog trim setting, the digital trim must be set to "0" (zero). Please refer to TDK-Lambda "PFE1500 PMBus Specification and Application Note" for additional information.

**Trim Up:** With a trim resistor connected between the Trim pin and Vout (+) pin, the output voltage is adjusted up. To adjust the output voltage to  $V_{o,desired}$  from  $V_{o,nom}$ , the trim resistor (in  $M\Omega$ ) should be chosen according to the following equation:

$V_{oNom}$  = Module nominal output voltage

$V_{oDesired}$  = Desired trim output voltage

$$V_A = 1.22 + 1.429 \left( \frac{V_{oDesired}}{V_{oNom}} - 1 \right) \quad \text{Formula 8-1}$$

$$R_{TrimUp} = \frac{V_{oDesired} + 1.941 - 2.59 * V_A}{V_A * 3111.2 - 379.9} \quad (M\Omega) \quad \text{Formula 8-2}$$

The trim-up resistor ( $R_{trim\_up}$ ) values from +5% to +30%, can be found in Table 8-1. The trim-up circuit connection is shown in Figure 8-2. Trim resistors should have +/-1% or better tolerance.

Table 8-1 External Trim-Up Resistor Values				
PFE1500FB-28-xxx			PFE1500FB-48-xxx	
% Trim-Up of $V_{o\_nom}$ ( $V_o$ )	Trim-Up Resistance ( $k\Omega$ )	Calculated Vout (V)	Trim-Up Resistance ( $k\Omega$ )	Calculated Vout (V)
+ 5%	1272	29.4	2230	50.4 V
+ 10%	660	30.8	1160	52.8 V
+ 15%	458	32.2	804	55.2 V
+ 20%	357	33.6	627	57.6 V
+25%	296	35.0	N/A	N/A
+30%	256	36.4	N/A	N/A

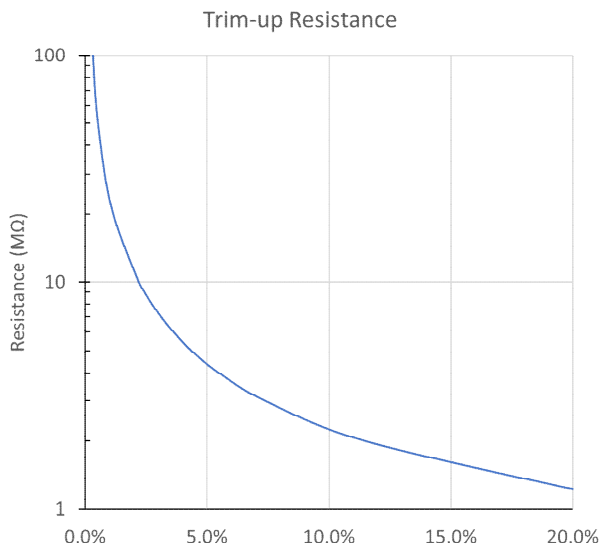

Fig. 8-1 Trim-Up Resistance vs. Percentage Voltage Trim-Up.

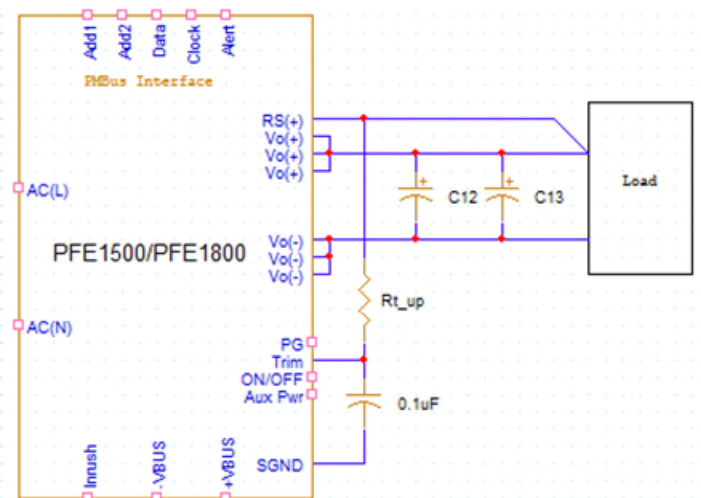

Fig. 8-2 External Trim-Up Circuit Connection.

**Trim Down:** With a resistor connected between the Trim pin and Vout (-) pin, the output voltage is adjusted down. To adjust the output voltage down from  $V_{o,nom}$  to a value  $V_{oDesired}$ , the trim resistor should be chosen according to the following equation (in  $k\Omega$ ).

$$R_{trimdown} = \frac{8660}{\left(\frac{3.29}{V_A} - 2.695\right)} - 5110 \quad (k\Omega) \quad \text{Formula 8-3}$$

$$V_A = 1.22 + 1.429 \left( \frac{V_{oDesired}}{V_{oNom}} - 1 \right) \quad \text{Formula 8-4}$$

The trim-down resistor ( $R_{trim\_down}$ ) values for the trim-down voltage range from -5% to -20% can be found in Table 8-2. The trim down connection diagram is shown in Figure 8-4.

Table 8-2 External Trim-Down Resistor Values				
% Trim-Down of $V_{o\_nom}$ ( $V_o$ )	PFE1500FB-28-xxx		PFE1500FB-48-xxx	
	Trim-Down Resistance ( $k\Omega$ )	Calculated Vout (V)	Trim-Down Resistance ( $k\Omega$ )	Calculated Vout (V)
- 5%	46.0	26.6	46.0	45.6 V
- 10%	19.0	25.2	19.0	43.2 V
- 15%	9.9	23.8	9.9	40.8 V
- 20%	5.4	22.4	5.4	38.4 V

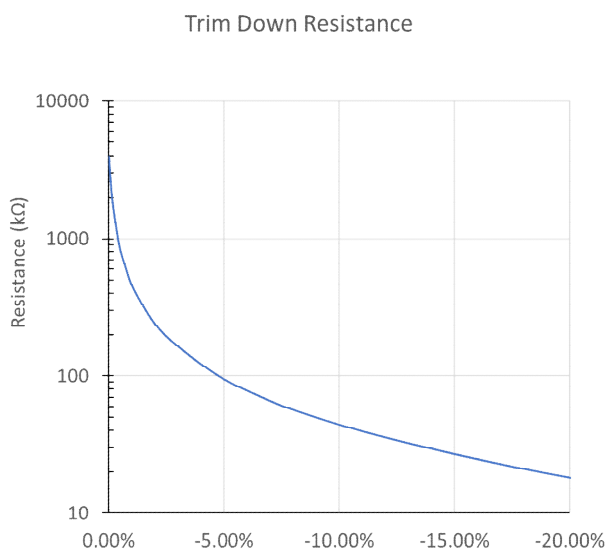

Fig. 8-3 Trim-Down Resistance vs. Percentage Voltage Trim-Down.

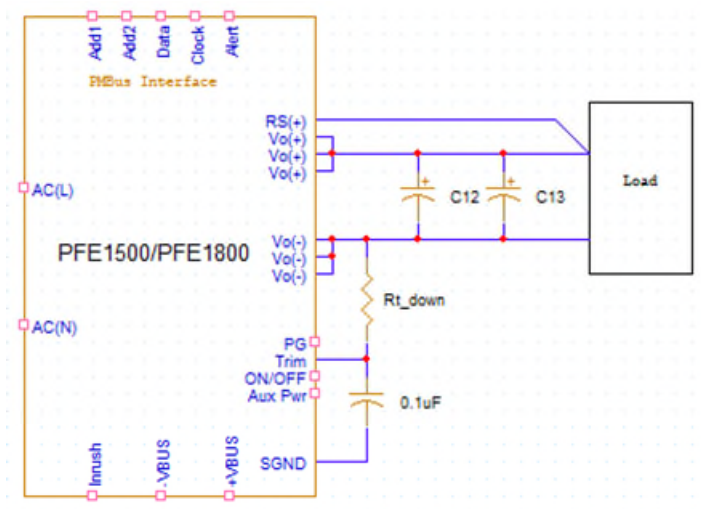

Fig. 8-4 External Trim-Down Circuit Connection.

## 8.4 Inrush Current

Input inrush or surge current changes with thermal fuse resistor (R2 + R3) value and the external boost converter bulk capacitance value (C8,C9,C10 and C11). It is recommended that evaluation testing be performed in the application to confirm the inrush current value.

The inrush current peak values shown in the specification or data sheet are measured at nominal lines (115 Vac, 230 Vac and 277Vac), at 25 °C using the basic connection diagram shown in Figure 7-1.

The external line fuse should be chosen to handle the measured inrush peak current and the operating current marked on the PFE product label. If a circuit breaker is used in conjunction with the line fuse, it should be selected using the same criteria.

## 8.5 High-Voltage Bus (or VBUS) Over Voltage and Under Voltage Protection

PFE Series modules monitor the VBUS voltage to protect the power module from operating with an over-voltage or under-voltage condition. If a module reaches these pre-defined protection levels, the module's output will shut down and VBUS will also shutdown. The module will attempt to auto-restart after shutting down. The inhibiting time before restart depends on the value of the bulk caps and bleeder resistor values used.

## 8.6 Output Over Voltage and Under Voltage Protection

PFE Series modules monitor the voltage at the output terminals. If the output voltage exceeds the overvoltage protection limit, the power module will shut down and attempt to latch off the output; the PFC will continue to operate, and the high-voltage bus will remain charged. An off command must be issued to clear an output overvoltage fault and resume normal operation. The default setting of the output overvoltage protection is 62.4V for the nominal 48V model and 39.6V for the nominal 28V output. The over voltage protection is adjustable by PMBus and can be reduced from the default setting down to 80% of the nominal output voltage.

If the output voltage decreases below the undervoltage protection limit, the power module will enter a hiccup mode of operation and attempt to restart (refer to section 8.11). The default setting for the output under voltage protection is 30% of the nominal output voltage. The output under voltage threshold is user adjustable over PMBus.

## 8.7 Input Over Voltage and Under Voltage Protection

PFE Series modules monitor the voltage at the input terminals. When the PFE module detects the input voltage is above the specified operating range, the module will begin a shutdown sequence. The PFE module will attempt to auto-restart once the input voltage returns within the specified range. The input overvoltage protection is not user adjustable. The typical input overvoltage shutdown threshold is 315Vrms.

When the module detects an input voltage below the undervoltage threshold, the PFC will cease switching but the output voltage will remain regulated until the Vbus under voltage protection engages at which point the module will shut down and attempt to restart (refer to section 8.11). If AC input voltage returns before the Vbus under voltage protection engages, there will be no interruption to the output voltage. The typical undervoltage turn on voltage is 83Vrms and shutdown threshold is 81Vrms. At cold temperatures, the turn on threshold may increase to as high as 87Vrms. The input undervoltage protection is not user adjustable.

## 8.8 Output Current Rating

The PFE1500 uses several factors to calculate the allowable output current or full load capacity. The module monitors operating conditions and recalculates this value while the unit is active. The protection action taken when the current rating is exceeded depends on the output over current protection mode selected (see sections 8.9 and 8.10).

The PFE1500 module will automatically self-limit the allowable output power during operation by modifying the output current limit. The current limit determines what the allowable maximum output current is before protection functions will activate.

First, the module determines the allowable output power based on the applied AC input voltage.

- AC input voltage >170 Vrms, 1500 W output
- AC input voltage <170 Vrms, 1250 W output
  - Additional linear derating from 1250 W at 100 Vrms to 905 W at 85 Vrms (23 W/Vrms)

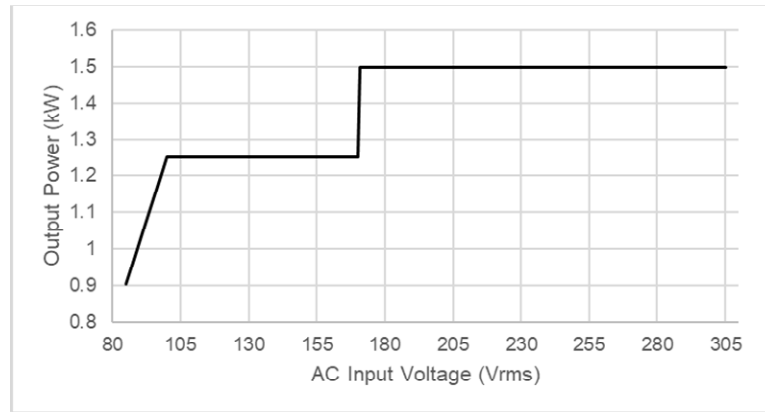

Figure 8-5 Output Power Rating versus Input Voltage

Second, the module determines what the allowable output current is based on the output voltage trim setting. Trimming up the output voltage will proportionally reduce the output current limit to stay within the output power rating per Equation 8-5.

$$I_{Limit} = \frac{P_{Limit}}{V_{TrimUp}} \quad \text{Equation 8-5}$$

Nominal, 10% trim up, and 20% up are given as examples in figure 8-6 and 8-7. When trimmed down to a lower output voltage, the module will not extend the allowable output current. The current limit when trimmed down is kept the same as the nominal output voltage case.

Third, the PMBus can be used to set a desired current limit from 10% to 100% of the rated max output current. Whichever current limit is lower, between the internally calculated current limit and the user-set current limit, will be used as the allowable output current setting. This allowable current is constantly updated during operation based on the above operational parameters and the user settings provided over PMBus.

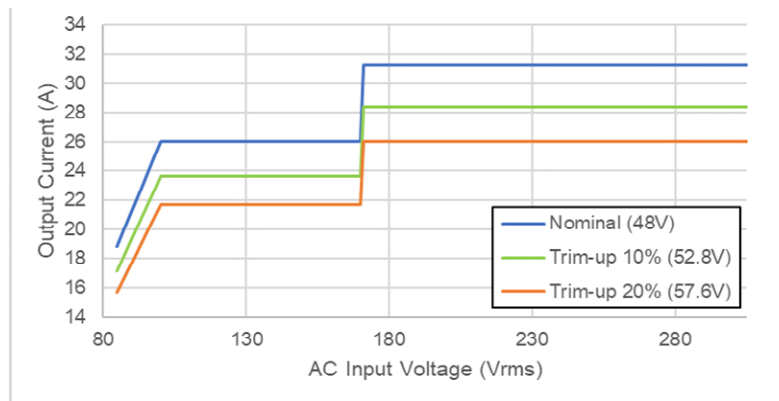

Figure 8-6 Allowable Output Current 48V output

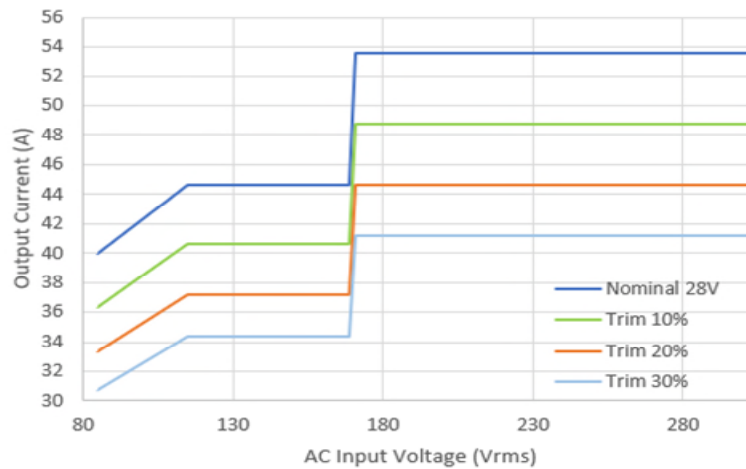

Figure 8-7 Allowable Output Current 28V output

## 8.9 Over Current Protection (OCP)

PFE Series modules are equipped with several OCP mechanisms, some of which depend on the output mode the PFE1500 is in. For all modes, the following protections are in place: AC input OCP, VBUS OCP, Output OCP, and Output short-circuit protection.

The module uses true load current information for fault detection to provide a high level of accuracy. The OCP trip point is set to a level slightly higher (on order of 10%) than the maximum allowable output current described in section 8.8.

The output OCP is a 2 second hiccup. If an output overload condition persists for approximately 250ms, the module will turn-off and attempt to restart after a nominal 2 second recovery delay time.

A second, faster acting output short circuit protection hiccup mode will engage at nearly twice the nominal output current setpoint to help protect against severe overload transients. This trip point is not adjustable. The module will attempt to restart after a nominal 2 second recovery delay time.

The PFE Series OCP setpoint can be reduced using the PMBus. Please refer to PMBus user manual for details.

### NOTE:

- (1) Certain Electronic Loads may have excessive current overshoot which can cause the PFE overcurrent protection to engage.
- (2) Operating beyond full load or in short circuit conditions for extended periods is not recommended and might result in power supply over-heating or damage.
- (3) In the low voltage range, allowable output current varies significantly with input voltage. Due to propagation delays in the sensing circuits, rapid changes in the line voltage may cause OCP to temporarily engage lower or higher than expected.

## 8.10 Constant-Current Voltage Foldback

An optional constant-current voltage foldback mode can be enabled using PMBus. In this mode, the PFE1500 will modulate the output voltage so that the steady-state output current does not exceed the current limit setting. Once the allowable output current is exceeded, the PFE1500 will control the output voltage such that the output current is held at the calculated allowable output current level described in section 8.8. If the load is reduced and the output voltage returns to its nominal value while in foldback mode, the PFE1500 will return to a constant voltage operating mode. Either output voltage or output current may briefly exceed their nominal limits during the transition between operating modes.

The voltage foldback control loop can be used for current regulation, but it is not fast enough to provide over-current protection or current regulation during fast load surges.

In case of a severe output overload of roughly double the current limit trip point, the PFE1500 module may enter a hiccup over current mode to reduce the risk of damage.

When in constant-current voltage foldback mode, the output voltage can only be reduced to the output under voltage protection limit, at which point an auto-recovery hiccup will occur. Using a constant-current electronic load that exceeds the output current limit will collapse the output voltage and trigger a UVP hiccup event.

### 8.11 Auto-Recovery Mode Option (Non-Latching)

Auto-Recovery refers to the module attempting to restart once an alarm condition has been removed and timer has cleared.

An alarm condition can be either Over-Voltage, Under-Voltage, Over-Current, or Auxiliary Bias Power Over-Load. For modules with non-latching faults, the module enters a 2-second hiccup retry sequence once an alarm condition has been detected.

### 8.12 Over Temperature Protection (OTP)

PFE Series modules are equipped with an internal OTP function. There are multiple thermal sensors located near hotspots in the PFE module. The digital controller reads back the temperatures sensed and will shut down the module if the temperature exceeds one of the pre-set OTP settings.

The module will re-start after the internal temperature drops below the restart point, approximately 20 °C below the trip point. Non-latching, auto-restart OTP is a standard feature for PFE modules.

Refer to Sections 9.1 and 9.3 for the external thermal measurement location of the PFE module and for the module's safe operating range.

### 8.13 Remote Sensing

PFE Series modules have one remote sensing terminal, RS(+), to compensate for the line drop between the output terminals to the output load. When remote sensing is not required, the RS(+) pin should be shorted to the Vout(+) pins. The output line drop (the voltage drop due to long cable impedance) and voltage compensation range must fall within the specified 3% output remote sense range. At any conditions, the maximum output power of PFE module should not be exceeded.

When using the remote sensing feature, do adequate evaluation to make sure the module does not have excessive noise or oscillation at the load terminals. If a filter inductor is inserted between the Vo(+) pin(s) and the load, the RS(+) sense should be connected on the module's side of the inductor. The remote sense terminal is noise sensitive and some precaution in the layout may be needed. Contact TDK-Lambda Technical Support for assistance if needed.

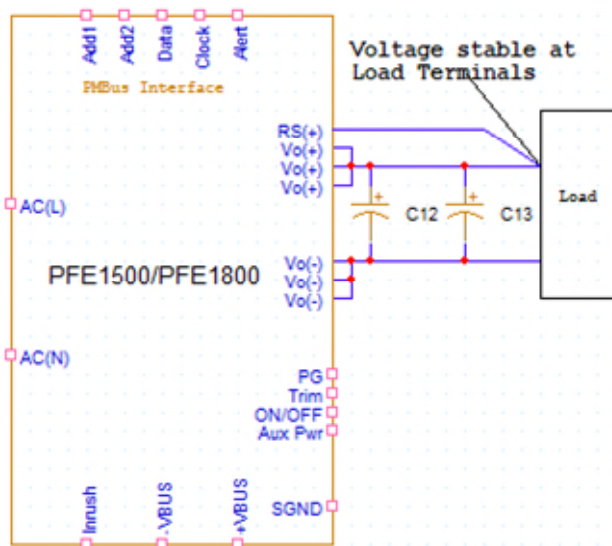

Fig. 8-8a Remote Sensing is USED.

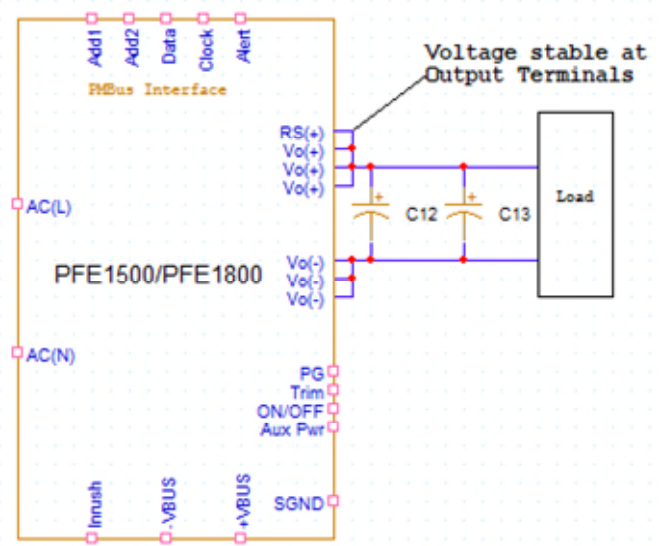

Fig. 8-8b Remote Sensing is NOT USED (Local Sensing).

## 8.14 ON-OFF Control

PFE Series modules have an ON-OFF control pin, referenced to SGND, which can be used to enable or disable the power module. When this pin is low, the PFE module is enabled. Internally, this pin is connected to a 10 kΩ pull-up resistor that is in series with 3.3 V source. An external 0.1 μF capacitor should be placed from the ON-OFF pin to SGND as shown in figure 8-9b.

Maximum sink current of ON-OFF pin	: 300uA
Minimum voltage for ON-OFF pin	: 0.0 V
Maximum voltage of ON-OFF pin	: 3.6 V

Low going (ON) threshold	: 1.4V typ.
High going (OFF) threshold	: 1.9V typ.

The digital controller inside the PFE module will remember which method was used to turn ON the module, either the ON-OFF pin or the PMBus OPERATION COMMAND. If the module is enabled by ON-OFF pin, then it must be turned off by ON-OFF pin. Attempts to turn off the module using the PMBus will be ignored.

If the module is enabled by PMBus control, then it must also be turned off through PMBus control. Attempts to turn off the module using the ON-OFF pin control will be ignored.

Both enable mechanisms are persistent, so sending turn-on commands using both the ON-OFF pin and PMBus control is not recommended to ensure the module will remain off when an off state is desired.

Rapid toggling of the enable pin is not recommended. There is a short delay time before the module will attempt a start-up if it is turned off and back on too quickly.

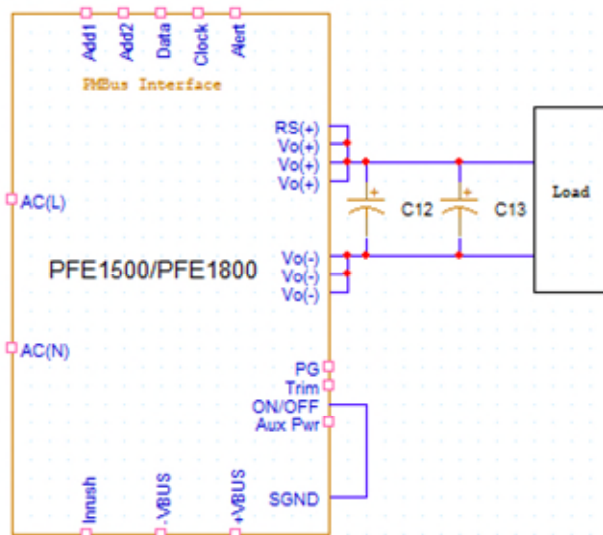

Fig. 8-9a ON-OFF Pin Tied Active.

**NOTE:** Module is always ON

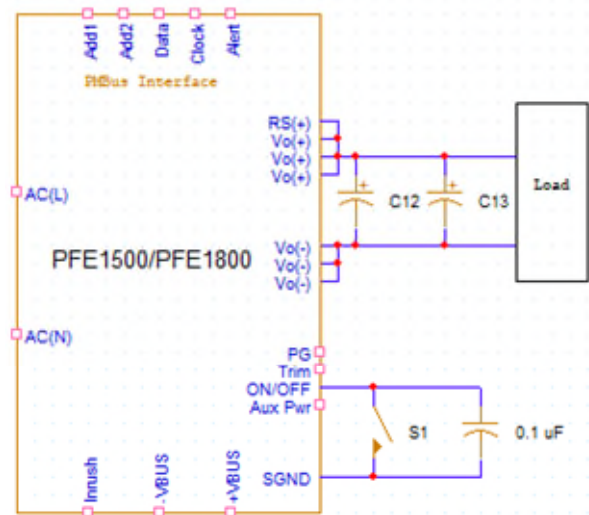

Fig. 8-9b ON-OFF Control Using Switch.

**NOTE:** S1 should be located next to the module

## 8.15 Power Good Signal (PGood)

PFE Series modules have an Open-Drain Power Good pin. The PGood pin can be used as a signal to turn loads on or off, or communicate with external controllers and signal the system regarding the status of the PFE module. An external pull-up resistor is required to limit sink current to less than the specified value.

When the output voltage of PFE module is within the specified output voltage regulation band, the Power Good signal is activated. An active “Low level” indicates Power Good.

Maximum sink current of Power Good pin	: 150 mA
Maximum voltage of Power Good Pin	: 50 V
V <sub>OUT_LOW</sub> (Max)	: 1 V @ 150 mA

It is recommended to use the Power Good signal to ensure the PFE output has reached regulation before enabling downstream loads. Filtering of the power good signal may be required in applications with high noise levels.

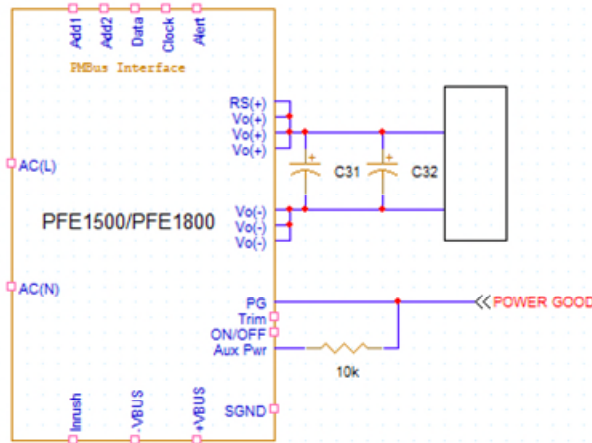

Figure 8-9c Power Good Signal Implementation

## 8.16 Auxiliary Bias Power

PFE Series modules have an Auxiliary Bias Supply pin, referenced to SGND. It provides a loosely regulated 12 V bias (9.5 -14 V), with a 200 mA maximum current rating. The auxiliary bias supply output is enabled whenever the PFE module is provided a source voltage within its rated input voltage range. The auxiliary bias supply is internally protected against overloads and will typically current limit in the range of 250mA. A severe overload may cause both the auxiliary bias and the PFE module to shut down. The auxiliary bias supply voltage and PFE module will auto-recover after the overload condition is removed.

## 8.17 Droop Load Share (Parallel Operation)

Droop load sharing between PFE modules can be configured using PMBus. The droop load share scheme senses the module’s output load current, and then intentionally lowers the output voltage reference, which then in turns reduces the regulated output voltage as shown in Figure 8-10b. The default setting for the PFE module is droop load sharing is enabled, but the droop rate is set to 0mV/A which is not suitable for parallel operation with current sharing.

The PFE module contains internal diodes to prevent negative current from flowing into the PFE module(s), so external OR-ing devices are not required unless paralleling for redundancy. However, the parallel modules do require a minimum decoupling impedance between them to stabilize the system. This impedance should be located after the required output capacitors and be on the order of 5 milliohms. If this impedance cannot be guaranteed by the wiring or PCB trace design, discrete resistors Ro1 and Ro2 should be inserted as shown in Figure 8-10a. The resistor power losses should be calculated at the expected full load current to avoid overstress.

The load share accuracy is a function of the module’s output voltage accuracy, load current sensing accuracy, output wiring impedance differences, and the droop rate selected. A higher droop rate will improve the current sharing between parallel

modules but create a wider variation in the output voltage at the load as the load current varies. Typically, the load current should be derated by 10% or more when operating in parallel to account for uneven current sharing. A droop rate of 40mV/A is generally sufficient to achieve 10% sharing between worst case modules. Contact TDK-Lambda for additional support meeting parallel system design requirements.

When using droop current sharing, the RS (+) needs to be connected for local sense mode, i.e. to Vo (+) pins.

It is recommended that the load is enabled after the system output voltage has been established (e.g. use the PFE module's Power Good signal to enable the load). Otherwise, since PFE modules feature hiccup OCP, there is risk of start-up problems if the load current is beyond the output current rating of a single module.

**NOTES:** *The Auxiliary Bias Power supplies cannot be connected in parallel.  
 The SGND pins of parallel PFE modules should not be tied together.*

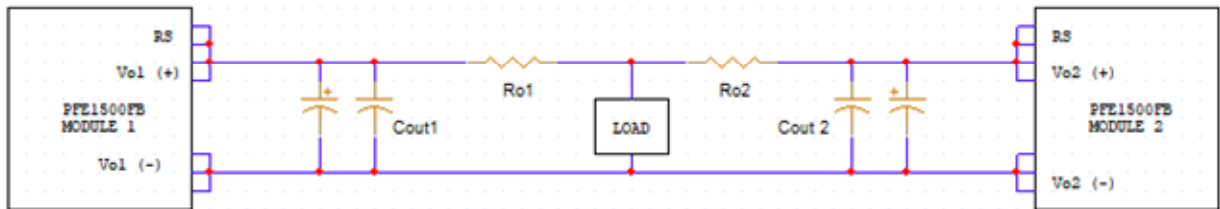

Fig. 8-10a Droop Load Share Configuration

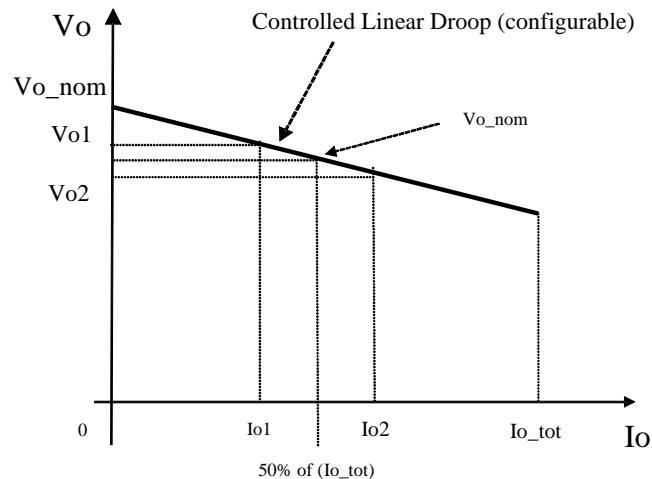

Fig. 8-10b Droop Load Share of two PFE1500 modules

## 8.18 Series Operation

To achieve higher output voltages using PFE Series modules, it is possible to connect two or more PFE1500 Series modules in series. For two modules connected in series configuration, the connection diagrams are shown in Figure 8-11a and Figure 8-11b. The output voltage of each module can be adjusted using the output voltage trim to different levels to achieve the desired total output voltage. The RS(+) pin needs to be connected in local sense mode, i.e. to Vo(+) pin(s). Care must be taken when using the ON-OFF feature or PMBus features in this configuration due to each module's SGND being at different voltage potentials. Optocouplers or other isolated devices are needed. Contact TDK-Lambda Customer Support for assistance with series operation.

$$V_{outTotal} = V_{out1} + V_{out2}$$

(Formula 8-6)

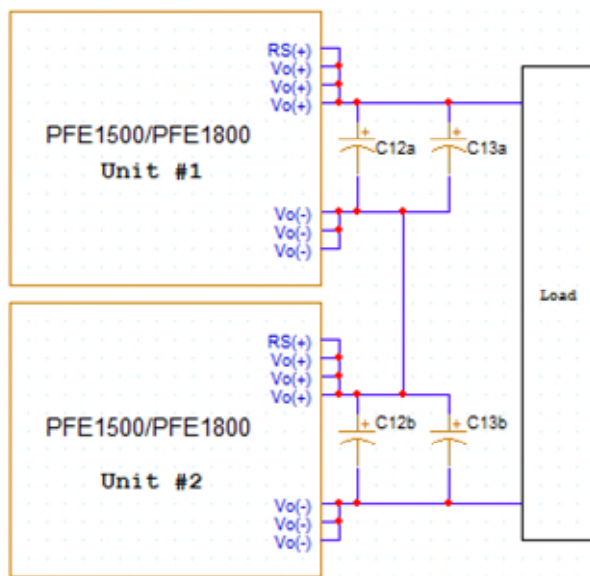

Fig. 8-11a Series Operation #1 (Higher Output Voltage).

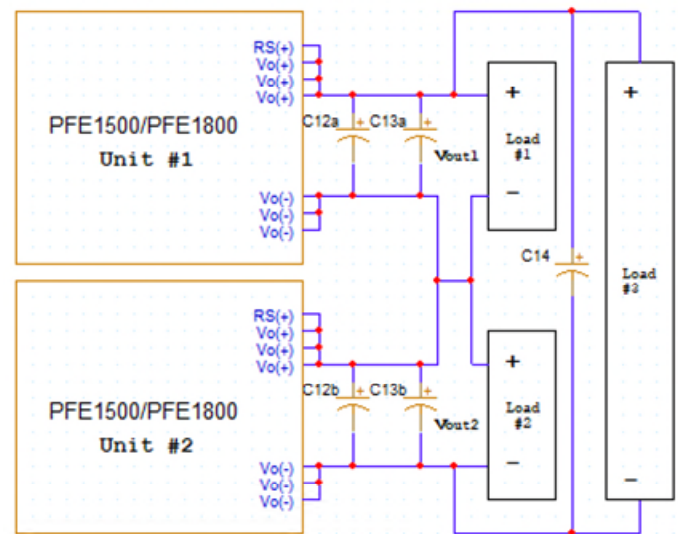

Fig. 8-11b Series Connection #2 (Different Load with Different Output Voltage).

## 8.19 PMBus Communication

The PFE Series module is PMBus compliant. This allows the host computer to communicate with the PFE module controller to either read out, command, or set certain module operating parameters.

PFE Series module operating status and telemetry can be monitored over the PMBus. PMBus can also be used to modify some of the operation parameters and limit settings. For details, please refer to TDK-Lambda “PFE1500/1800 PMBus Specification and Application Note”.

**NOTE:** When the PMBus feature set is being used, resistors are required to configure the device address as shown in Figure 8-12. For resistor values, please refer to the TDK-Lambda PMBus Specification and Application Note. External 2200 pF capacitors should be placed in parallel with the address resistors, from the PMBus\_Add1 pin to SGND and PMBus\_Add2 pin to SGND.

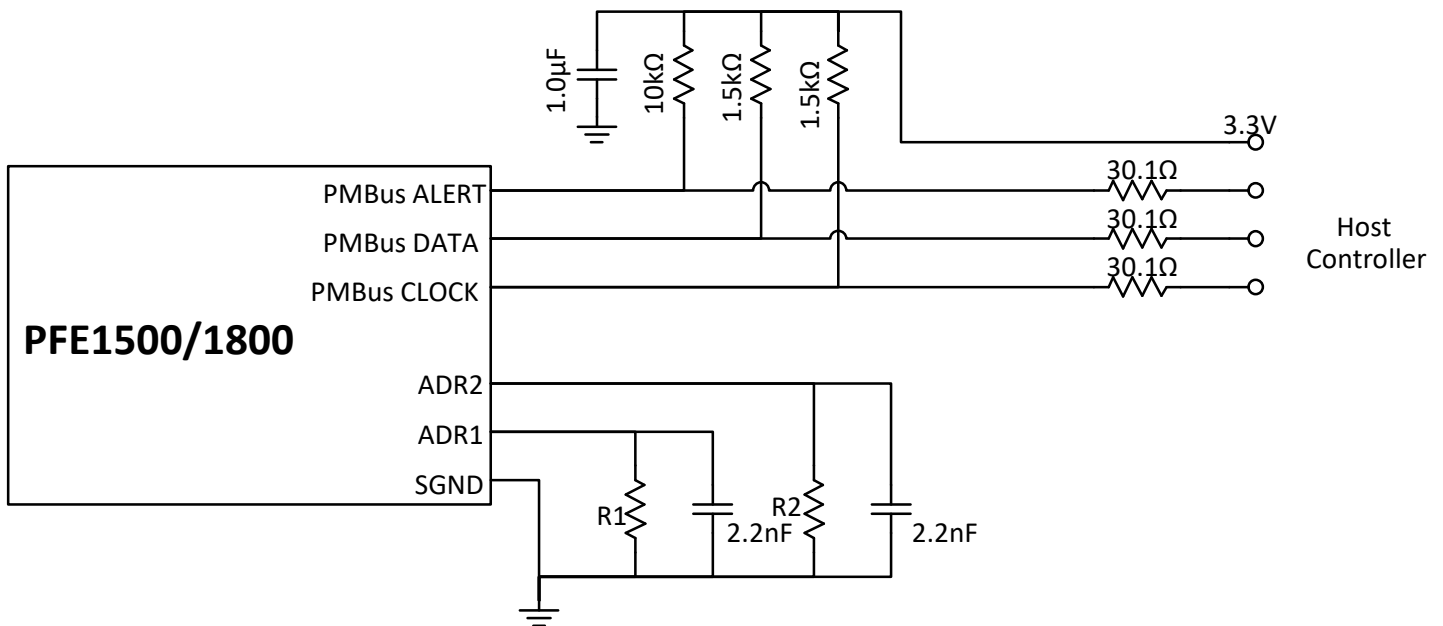

Fig 8-12 PMBus Addressing Configuration

## 8.20 Ripple and Noise

The output noise measurement connection can be found in the diagram shown in Figure 8-13 below.

A 0.1  $\mu\text{F}$  ceramic capacitor, C15, and eight 4.7  $\mu\text{F}$  ceramic capacitors, C14, are connected across the PFE module's output bus at a location 50 mm from the module output terminals. The ceramic capacitors are in parallel with the required bulk output electrolytic capacitors. An oscilloscope set to 20 MHz bandwidth is used to measure peak-peak and RMS ripple values.

Note that the measured high frequency noise spikes vary depending on the wiring pattern of the printed circuit board, the contact impedance of the scope coaxial cable connection and the exact physical configuration of the test setup.

In general, the module's output ripple spikes can be reduced by increasing external ceramic capacitor quantity and value.

**NOTE:** Noise is an RF frequency measurement that requires RF measurement techniques. Do not use flying ground leads on oscilloscope probes. An RF connector is required for accurate measurements.

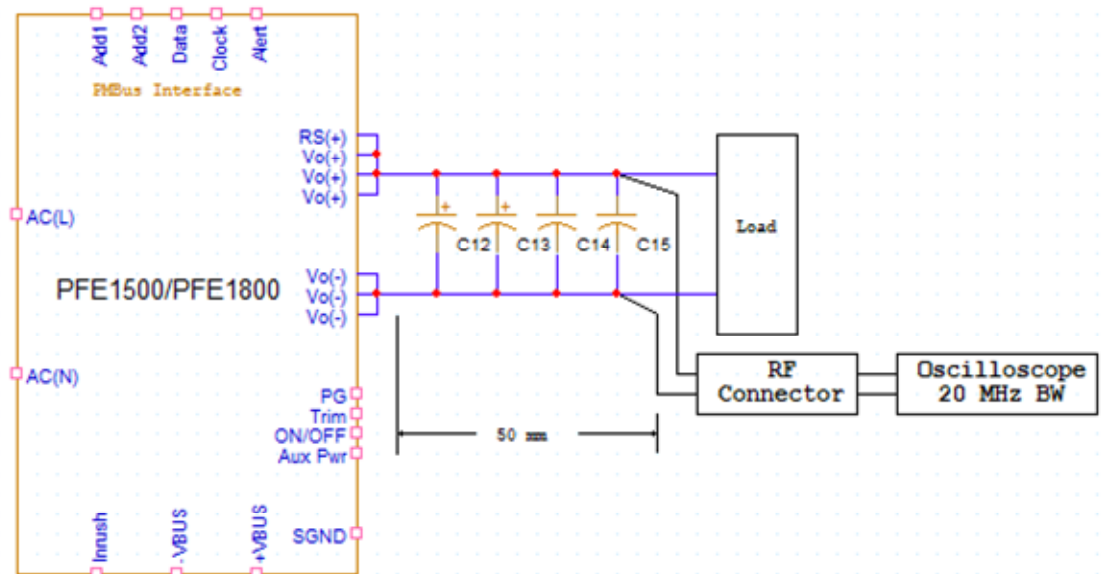

Fig 8-13 Output Noise or Ripple (including Spike Noise) Measurement Method.

## 8.21 Withstand Voltage Test (Hipot Test)

PFE Series modules are designed to withstand 2.5 kVac between input and module case, 3.0 kVac (reinforced insulation) between input and output, and 1.5 kVdc between output and case, each for 1-minute dwell. When testing withstand voltage, set the leakage current limit of the Hipot tester to 20 mA.

Only DC Hipot test voltages should be applied between output and case. AC test voltages between output and case may damage PFE modules.

The applied voltage must be gradually ramped from zero volts to the preset testing level, and then gradually decreased back to zero volts. The ramp rate must not exceed 300 Vrms/sec and the dwell time should be 1 sec in mass production or 60 seconds during the safety qualification test. Connect each terminal of PFE module according to the circuit diagrams as shown in Figure 8-14a, Figure 8-14b, and Figure 8-14c.

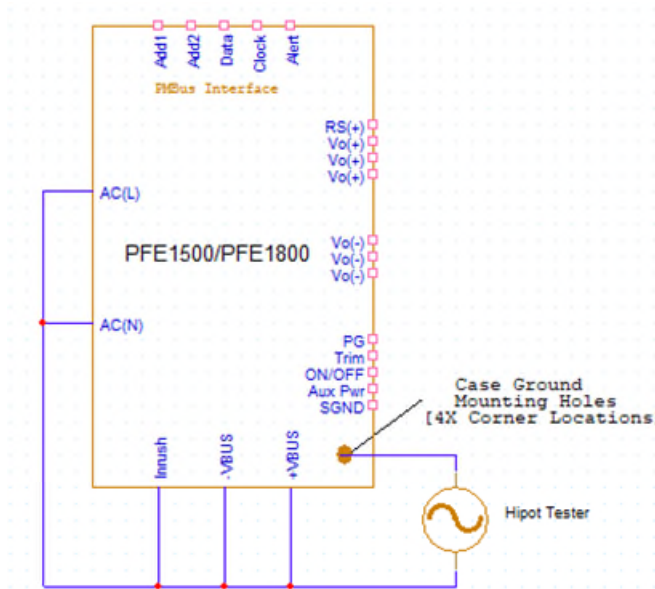

Fig. 8-14a Input to Case Hipot Test Method.

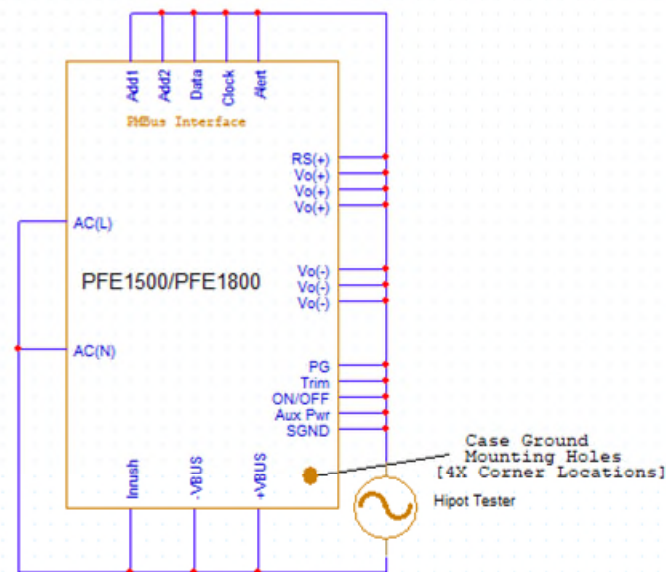

Fig. 8-14b Input to Output Hipot Test Method.

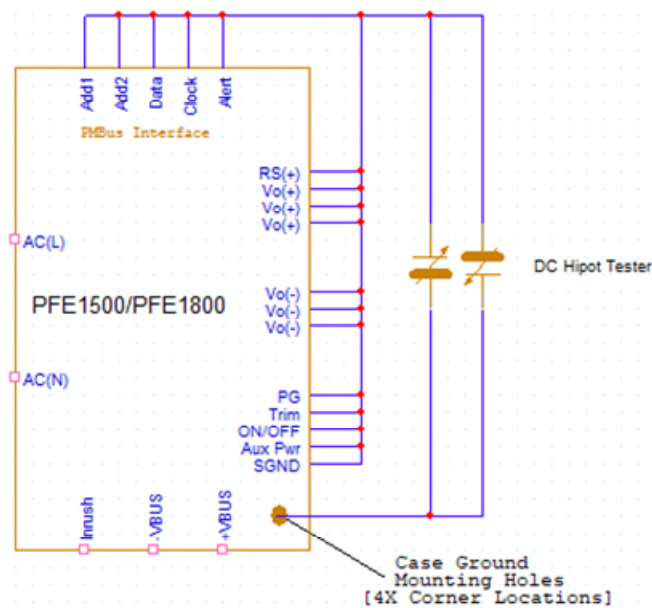

Fig. 8-14c Output to Case Hipot Test Method.

### Withstand Voltage Testing with External Supporting Circuitry

The Withstand Voltage Testing described applies to PFE Series power modules as stand-alone units. If the Withstand Voltage Testing is to be performed at the system level with the required supporting circuitry such as shown in Fig. 7-1 installed, care must be taken to check and verify the voltage rating of all the selected external capacitors, MOVs, and spark gaps or other components that may be present between the Input terminals and Case, and Output terminals and Case.

## 9 Thermal Considerations and Mounting Method

### 9.1 Thermal Consideration

The PFE Series module is designed for both convection and conduction cooling applications.

This product can be mounted in any orientation, but for forced convection applications, be sure to provide adequate airflow around the power supply to avoid heat accumulation. Consider layout of surrounding components and orient the PFE such that air flow across module is optimized.

It is recommended that this product operate when case temperature is maintained at or below the derating curves as shown in Figure 9-2. The maximum case temperature should be 100 °C or less regardless of the input operating line voltage and/or frequency. For any technical issues related to thermal derating, thermal test set-up, mounting, heat sink attachment, and use of the thermal interface material, please contact TDK-Lambda Americas for technical support.

Case temperature thermal measurement location is shown in Fig. 9-1.

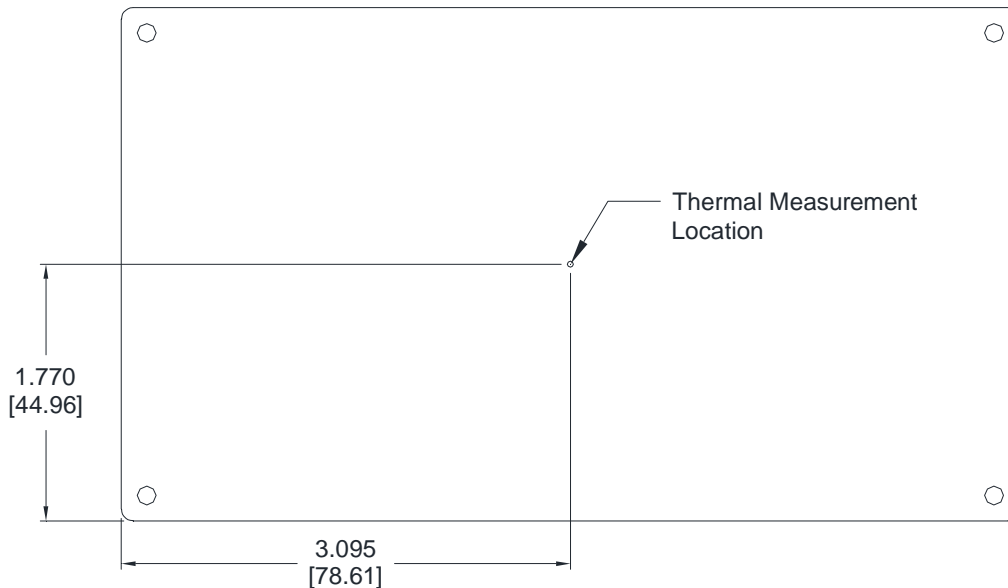

*Fig. 9-1 Baseplate Temperature Measuring Point.*

## 9.2 Thermal Test Setup

The thermal derating curves in Section 9.3 are based upon measurements obtained in a test setup that simulates typical conduction cooled applications. The PFE module is isolated from the external ambient air so there is no forced convection. A large heatsink is attached to the PFE metal case to maintain its case temperature. The power module is mounted onto a 6-layer 2oz copper PCB with pins connected to power planes on multiple layers. The PFE internal construction consists of a single multilayer PCB installed inside a five-sided insulated metal case with thick copper power pins to connect the module to the mounting PCB. Heat is transferred from the module pins into the mounting board. If this heat transfer mechanism is reduced, lower maximum case operating temperatures can result. Contact TDK-Lambda technical support for additional assistance with thermal management of PFE power modules.

## 9.3 Output Current / Case Temperature Thermal Derating

PFE1500F module is derated according to Figure 9-2 and 9-3. Derating varies based on AC input voltage and desired case temperature/output current.

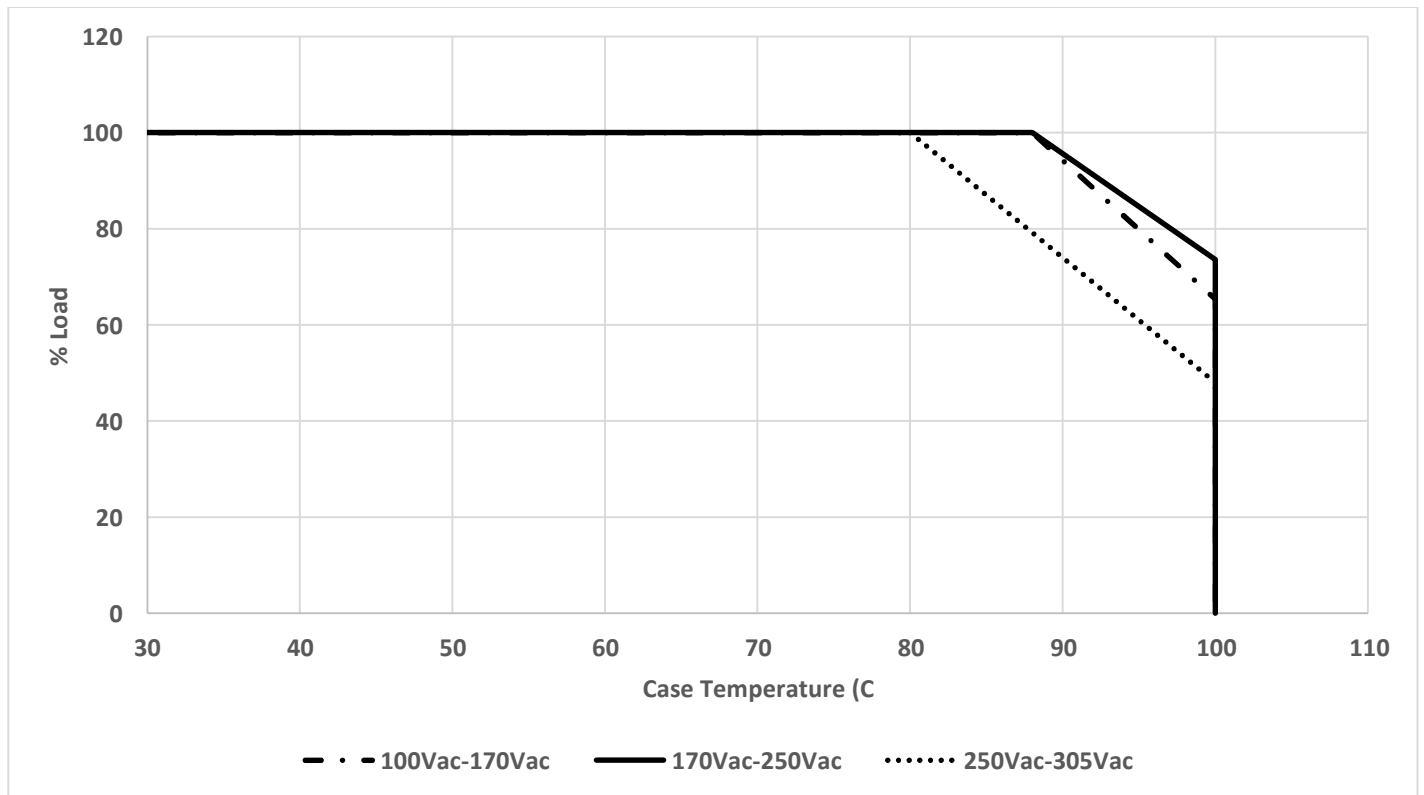

Fig. 9-2 PFE1500FB-48-xxx Derating Curves.

(To be added in future revision)  
 Fig. 9-3 PFE1500FB-28-xxx Derating Curves.

## **9.4 Recommended Soldering Condition**

Recommended soldering temperature is as follows:

Soldering Dip :  $260 \pm 5$  °C, within 10 seconds  
Preheat : 130 °C

## **9.5 Recommended Washing Condition**

After soldering, the following washing condition is recommended:

- (1) Recommended washing solution  
IPA (Isopropyl Alcohol)
- (2) Washing method  
In order to avoid penetration inside the power module, washing should be done with brush. Then, dry up thoroughly after washing.

For other washing conditions, consult TDK-Lambda Americas Technical Support.

## **10 Warranty Period**

Standard warranty is 3 years or whatever is specified on the purchasing agreement.

The following cases are not covered by warranty:

- (1) Improper use like dropping products, applying excessive shock, spilling fluids on the module, etc.
- (2) Operating the PFE Series module outside the specification or not following this Instruction Manual.
- (3) Defects resulting from natural disaster (fire, flood, earthquake, tornado, hurricane, etc....).
- (4) Unauthorized modifications or repair by the buyers/customers.

## 11 Appendix

### 11.1 EMI Conducted Emissions CISPR 32:2015 Class A Recommended Values

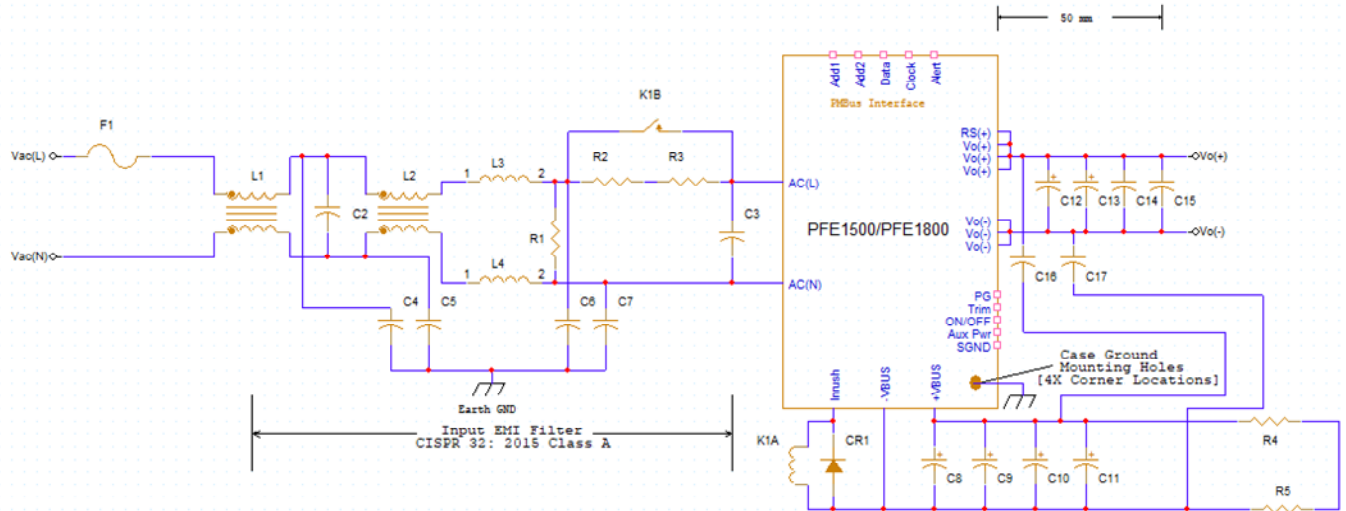

**Figure 11.1 PFE1500-48-xxx-R**

C2	0.47uF film capacitor	F1	20A, 280 V, Fast Acting Fuse
C3	3.94uF film capacitor	L1	1mH
C4, C5, C6, C7	4700pF ceramic capacitor	R1, R4, R5	470 k $\Omega$ , 2 W
L2	1.3mH	R2, R3	10 $\Omega$ , 5 W
C16, C17	7500pF ceramic capacitor	CR1	CRH01, 200V, 1A Diode
C8, C9, C10, C11	470uF, 500V	L3, L4	27uH
C12, C13	560uF electrolytic capacitor	K1	1 Form A relay with 16 A, 277 Vac, power rating: 12 Vdc, 16.7 mA, 200 mW, High Sensitivity
C14	37.6uF ceramic capacitor	C15	0.1uF ceramic capacitor

**⚠ DANGER**

Never use this product in locations where flammable gas or ignitable substances are present. There are potential risks of igniting these substances caused by arcing.

**⚠ WARNING**

- Do not touch this product or its associated components while circuit is live, or shortly after shut down. There may be high voltage or high temperature present and you may receive an electric shock or burn.
- While this product is operating, keep your hands and face away from it as you may be injured by an unexpected situation.
- Do not make unauthorized changes to this product, otherwise you may receive an electric shock. It will also void the product warranty.
- Do not drop or insert anything into the product. It might lead to a failure, fire or electric shock.
- Do not use this product if abnormal conditions such as emission of smoke and/or abnormal smell, etc... are present. It might lead to fire and/or electric shock. In such cases, please contact TDK-Lambda. Do not attempt to repair by yourself, as it is dangerous for the user.
- Do not operate these products in the presence of condensation. It might lead to fire or electric shock.

**⚠ CAUTION**

- This power supply is designed and manufactured for use within an end product such that it is accessible only to trained SERVICE ENGINEERS.
- Confirm that the connections to input/output terminals, and signal terminals are correct as specified in this instruction manual before turning on the power.
- Input voltage, Output current, Output power, ambient temperature, case temperature, and ambient humidity should be kept within the specifications, otherwise the product may be damaged.
- Do not operate or store this product in an environment where condensation can occur. Waterproofing treatment or special storage and handling are necessary.
- The equipment has been evaluated for use in a Pollution Degree 2 environment.
- Do not use this product in environments with strong electromagnetic fields, corrosive gas, or conductive substances.
- For applications, which require very high reliability, such as nuclear related equipment, medical equipment, traffic control equipment, etc., it is necessary to provide a fail-safe mechanism in the end equipment.
- Do not inject abnormal voltages into the output terminals or signal terminals of this product. The injection of reverse voltage or over voltage exceeding nominal output voltage into these terminals can damage the internal components of the product.
- Never operate the product under over-current or short circuit conditions. Failure or other damage may occur.
- The output voltage of this power supply unit is considered to be a hazardous energy level. It must not be made accessible to users. Protection must be provided for Service Engineers against indirect contact with the output terminals and/or to prevent tools being dropped across them. While working on this product, the AC input power must be switched off, and the input, output, +VBUS, and -VBUS terminal voltages should be confirmed to be at a safe level.
- The application circuits and their parameters are for reference only. Be sure to verify effectiveness of these circuits and their parameters before finalizing the circuit design.
- Use a Fast-Blow external fuse to each module to ensure safe operation and compliance with the safety standards to which it is approved. The recommended input fuse rating within the instructions is as follows: 20A, 280V fast acting fuse. The breaking capacity and voltage rating of this fuse may be subject to the end use application.

## 12 Document History

Revision:	Date:	Description:
0.1	9/28/23	Preliminary Draft
0.3	9/10/24	First complete version sent for review
0.4	9/20/24	After review
1.0	10/29/24	Minor updates, first issued version
1.1	4/3/25	Modifications before product release
2.0	12/03/25	Initial release version
3.0	3/12/26	Implement minor clarifications based on feedback

Information furnished by TDK-Lambda is believed to be accurate and reliable. However, TDK-Lambda assumes no responsibility for its use, nor for any infringement of patents or other rights of third parties, which may result from its use. No license is granted by implication or otherwise under any patent or patent rights of TDK-Lambda. TDK components are not designed to be used in applications, such as life support systems, wherein failure or malfunction could result in injury or death. All sales are subject to TDK-Lambda's Terms and Conditions of Sale, which are available upon request. Specifications are subject to change without notice.



**TDK-Lambda France SAS**  
Tel: +33 1 60 12 71 65  
tif.fr.powersolutions@tdk.com  
www.emea.lambda.tdk.com/fr



**Italy Sales Office**  
Tel: +39 02 61 29 38 63  
tif.it.powersolutions@tdk.com  
www.emea.lambda.tdk.com/it



**Netherlands**  
tif.nl.powersolutions@tdk.com  
www.emea.lambda.tdk.com/nl



**TDK-Lambda Germany GmbH**  
Tel: +49 7841 666 0  
tlg.powersolutions@tdk.com  
www.emea.lambda.tdk.com/de



**Austria Sales Office**  
Tel: +43 2256 655 84  
tlg.at.powersolutions@tdk.com  
www.emea.lambda.tdk.com/at



**Switzerland Sales Office**  
Tel: +41 44 850 53 53  
tlg.ch.powersolutions@tdk.com  
www.emea.lambda.tdk.com/ch



**Nordic Sales Office**  
Tel: +45 8853 8086  
tlg.dk.powersolutions@tdk.com  
www.emea.lambda.tdk.com/dk



**TDK-Lambda UK Ltd.**  
Tel: +44 (0) 12 71 85 66 66  
tlu.powersolutions@tdk.com  
www.emea.lambda.tdk.com/uk



**TDK-Lambda Ltd.**  
Tel: +9 723 902 4333  
tli.powersolutions@tdk.com  
www.emea.lambda.tdk.com/il-en



**TDK-Lambda Americas**  
Tel: +1 800-LAMBDA-4 or 1-800-526-2324  
tia.powersolutions@tdk.com  
www.us.lambda.tdk.com



**TDK Electronics do Brasil Ltda**  
Tel: +55 11 3289-9599  
sales.br@tdk-electronics.tdk.com  
www.tdk-electronics.tdk.com/en



**TDK-Lambda Corporation**  
Tel: +81-3-6778-1113  
www.jp.lambda.tdk.com



**TDK-Lambda (China) Electronics Co. Ltd.**  
Tel: +86 21 6485-0777  
tlc.powersolutions@tdk.com  
www.lambda.tdk.com.cn



**TDK-Lambda Singapore Pte Ltd.**  
Tel: +65 6251 7211  
tts.marketing@tdk.com  
www.sg.lambda.tdk.com



**TDK India Private Limited, Power Supply Division**  
Tel: +91 80 4039-0660  
mathew.philip@tdk.com  
www.sg.lambda.tdk.com

