

GENERAL SAFETY INSTRUCTIONS	2
High Voltage Warning.....	2
Critical Components	2
Servicing.....	2
Safety Class of Protection.....	2
Installation	2
Ratings, Specifications and Features	4
Emissions.....	4
Immunity	4
Maximum Ratings	5
Input Specifications	5
Output Performance Specifications	6
Protective Functions	6
Operating Modes	6
DC Output Controls and Indicators	7
Remote Control Features	7
PMBus Features.....	7
Input, Output and Signal Connections	8
Signal Connector	9
Local Sense Setup.....	11
Remote Sense Setup	11
Parallel Operation Setup	12
Series Operation Setup	14
Ripple and Noise Notes	16
Mechanical Drawing.....	17
PMBus Interface.....	18

GENERAL SAFETY INSTRUCTIONS

High Voltage Warning

Dangerous voltages are present within the power supply.

Critical Components

This product is not authorized for use as a critical component in nuclear control systems, life support systems or equipment for use in hazardous environments without the express written approval of the Engineering Director of TDK-Lambda Americas.

Servicing

This product is not customer serviceable.

Unit repairs shall only be carried out by TDK- Lambda Americas or their Authorized agents.

Contact: TDK-Lambda Americas
401 Mile of Cars Way, Suite 325
National City, CA 91950
Tel 619-575-4400
Fax 619-575-7185

Safety Class of Protection

The unit is designed for the following parameters: Material Group IIIb, Pollution Degree 2, Overvoltage Category II, Class 1 (earthed), Indoor use. The unit is considered as fixed and rated IPX0. The TPS400012, TPS400024 and TPS400048 are classed as having SELV outputs. All outputs are capable of providing hazardous energy (>240VA). The final equipment should provide protection to service personnel against inadvertent contact with the PSU output terminals.

Installation

This product is designed for use within other equipment which restricts access to Authorized competent personnel only. The unit covers/chassis must not be made user accessible.

The appliance may be mounted in any orientation.

The mains input connector is not acceptable for use as field wiring terminals.

The appliance must be securely mounted and the baseplate properly bonded to the main protective earth contact before any connection to AC mains supply is made.

The ventilation openings must not be impeded – ensure a space at least 5cm between any obstruction and the ventilation openings.

BEFORE USING THE POWER SUPPLY UNIT

Be sure to read this instruction manual thoroughly before using this product. Pay attention to all cautions and warnings before using this product. Incorrect usage could lead to an electrical shock, damage to the unit or a fire hazard.

DANGER

- Never use this product in locations where flammable gas or ignitable substances are present.

WARNING

- Do not make unauthorized changes to power supply unit, otherwise you might have electric shock and void your warranty.
- Do not touch this unit and the internal components in operation or shortly after shut down. They might have high voltage or high temperature and as the unit dissipates its heat so the surface of the unit is hot. You might receive electric shock or burn.
- When the unit is operating, keep your hands and face away from it; you might be injured by an accident.
- Do not use unit under unusual conditions such as emission of smoke or abnormal smell and sound etc. It might cause fire and electric shock. In such case, please contact us; do not repair by yourself, as it is dangerous for the user.
- Do not drop or insert anything into unit. It might cause failure and fire.
- Do not operate these units under condensation condition. It might cause fire and electric shock.

⚠ CAUTION

- As a component part, compliance with the standard will be based upon installation in the final application. This product must be installed in a restricted access location, accessible to authorized competent personnel only. These AC to DC converters have reinforced insulation between the input and the output. The outputs of these products are energy hazards. The equipment has been evaluated for use in a Pollution Degree 2 environment.
- This product is designed for use within other equipment or enclosures which restrict access to authorized competent personnel only and must not be user accessible. Confirm connections to input/output terminals and signal terminals are correct as indicated in the instruction manual.
- Input voltage, Output current, Output power, ambient temperature and ambient humidity should be used within specifications, otherwise the unit will be damaged.
- For application equipment, which requires very high reliability (Nuclear related equipment, traffic control equipment, medical equipment, etc.), please provide fail safety function in the equipment.
- Do not use the product in environment with strong electromagnetic field, corrosive gas and conductive substance.
- Do not operate and store this unit at an environment where condensation occurs. In such case, waterproof treatment is necessary
- Never operate the unit under over current or shorted conditions for 30 seconds or more and out of Input Voltage Range as specification. Insulation failure, smoking, burning or other damage might occur to the unit.
- The output voltage of this power supply unit is considered to be a hazardous energy level (The voltage is 2V or more and the electric power is 240VA or more). Prevention from direct contact with output terminal is highly necessary. While installing or servicing this power supply unit, avoid dropping tools by mistake or direct contact with output terminal. This might cause an electrical shock. While repairing this power supply unit, the AC input power must be switched off and the input and output voltage should be level.
- To maintain the SELV output, under fault conditions, the output must be connected to earth in the final application.
- The application circuits and their parameter are for reference only. Be sure to verify effectiveness of application circuits and their parameters before finalizing circuit design.
- Do not inject abnormal voltage to output terminal and signal terminal from the outside. The injection of reverse voltage or over voltage exceeding nominal output voltage to output terminals might cause damage to internal components.
- This information in this document is subject to change without prior notice. For actual design-in, please refer to the latest publications of data sheet, etc., for the most up-to date specifications of the unit.

CE Marking, when applied to a product or packing material for a product covered by this handbook, indicates compliance with the Low Voltage Directive and RoHS Directive.

UKCA Marking, when applied to a product or packing material for a product covered by this handbook, indicates compliance with the Electrical Equipment (Safety) Regulations and Restriction of the Use of Certain Hazardous Substances in Electrical & Electronic Equipment Regulations.

Ratings, Specifications and Features

Emissions		
AC Line Conducted Emissions	EN 55032:2015	(0.15-30 MHz) Class A
Radiated RF Emissions	EN 55032:2015	0-1000 MHz Class A *
Immunity		
Electrostatic Discharge	IEC61000-4-2: 2008	+/-8 kV Air Discharge +/-4 kV Contact Discharge
RF Radiated Fields	EN61000-4-3: 2006 +A1:2008 +A2:2010	3 V/m from 80-1000 MHz; (80% AM at 1kHz)
Electrical Fast Transients	EN61000-4-4: 2004+A1:2010	Power line pulses of ± 1 kV; I/O line pulses of ± 0.5 kV
Lightning Surge	IEC61000-4-5: 2005	± 4 kV common mode (Line to Ground) ± 2 kV differential mode (Line to Line)
Conducted RF Common Mode	EN61000-4-6: 2009	150 kHz - 80 MHz at 3 Vrms 1 kHz 80% amplitude modulated
Power Frequency Magnetic Field	IEC61000-4-8:2009	30A/m (Continuous Field) 300A/m (Short Duration)
Voltage Dips/Short Variations	IEC61000-4-11:2004	5% of nom. line for .5 cycles - Criteria B 70% for 25 cycles - Criteria B 95% Dip for 5 seconds - Criteria C
Voltage Dips/Short Variations	SEMI F47-0706	50% of nom. line for 10 cycles - Criteria B 70% for 25 cycles - Criteria B 80% for 50 cycles - Criteria B
Regulatory		
RoHS	Refer to EU DECLARATION OF CONFORMITY for details	

Table 1

*With appropriate installation

Maximum Ratings				
	Units	TPS400012	TPS400024	TPS400048
Output Voltage Range (adjust via potentiometer)	V	9.6-14.4	19.2-28.5	38.4-58
Output Voltage Range (adjust via analog voltage) ⁵	V	9.6-14.4	19.2-28.5	38.4-58
Output Voltage Range (adjust via digital signal)	V	6-18	8-28.5	16-58
Maximum Output Current (Power) @ 50°C ^{1,2}	A(W)	170(2040)	170(4080)	85 (4080)
Maximum Output Current (Power) @ 50°C ²	A(W)	166(2000)	166(4000)	83.3(4000)
Maximum Output Current (Power) @ 60°C ²	A(W)	133.33(1600)	133.33(3200)	66.6(3200)
Maximum Output Current (Power) @ 70°C ²	A(W)	91.7(1100)	91.7(2200)	45.833(2400)
Maximum Output Power with Dropped Phase ³	A(W)	1200W	1600W	1600W
Minimum Current	A	Not needed		
Operating Temperature ⁴	°C	-10°C to 50°C. Derating 50°C-60°C - 2%/°C, 60°C-70°C 2.5%/°C		
Start-up Temperature ⁴	°C	-40°C to +70°C		

Table 2

¹ Output adjustment at 12V set point for TPS400012, 24V set point for TPS400024 and at 48V set point for TPS400048.

² Output current and power, as measured at output terminals, must be less than or equal to quoted maximum values for a given ambient temperature.

³ Dropped phase condition operation is considered an abnormal operation condition. It is not recommended to operate the unit in this mode permanently. Unit is able to handle the specified output power during dropped phase temporarily.

⁴ Operation at -40°C may require 10min warm up at 80% load to meet regulation and output ripple. Not all parameters are guaranteed at -40°C operation. For TPS400048, if output is adjusted below Vnom (48V) regulation is guaranteed from -20°C or above. Consult the factory for operation below -20°C & Vo < Vnom.

⁵ Output voltage adjustment range based on manual set point at 12V for TPS400012, at 24V for TPS400024 and at 48V set point for TPS400048

Input Specifications				
	Units	TPS400012	TPS400024	TPS400048
Input Voltage		VAC 400/480 (50/60Hz) Three Phase Delta		
Input Current (RMS) Per Phase 400-480VAC input	A	5.0	8.0	8.0
Inrush Current (Peak, at cold start) Per Phase, 400-480VAC input *	A	<25		
Power Factor (at rated output power) 400-480VAC input	-	0.88 typical	0.92 typical	
Input EMI Conducted Emissions	-	FCC Class A, CISPR 22 Class A		
Efficiency (at rated output power) 400-480VAC input	%	86% typical	92% typical	
Input Protection	-	10A 600V Fast Acting Fuse – Present on each phase (3 total) Internal – Not user accessible		

Table 3

*Excluding initial spike charging EMI capacitors lasting <2mS

Output Performance Specifications				
	Units	TPS400012	TPS400024	TPS400048
Max Voltage Line Regulation	%	Less than 0.25%		
Max Voltage Load Regulation	%	Less than 0.5%		
Total Regulation ⁵	%	Less than 1.75%		
Warm up Drift	%	Less than 0.2%		
Temperature Stability	-	0.05% of rated Vout for 8hrs after 30min warm-up. Constant line, load & temp.		
Temperature Coefficient	ppm/°C	200ppm/C		
Ripple/Noise P-P(20MHz), JEITA RC-9131C ⁵	mVp-p	120	240	480
Output Ripple, JEITA RC-9131C ⁶	mVrms	<1% of Vout	<0.5% of Vout	
Remote Sense Compensation (Total)	V	1.0V		

Table 4

⁵ Total Regulation at -40°C may require 10min warm up at 80% load to meet regulation and output ripple.

⁶ See Ripple and Noise Notes for Details on Jeita RC-9131C method; All Three Phases present

Protective Functions				
	Units	TPS400012	TPS400024	TPS400048
OCP TYPE	-	CONSTANT CURRENT / CONSTANT RESISTANCE		
OCP KNEE POINT	-	Adjustable (70% - 105% of max rated current)		
KNEE POINT PROTECTION	-	NONE. NO DAMAGE AT KNEE POINT		
S/C PROTECTION	-	CONSTANT CURRENT w/ time-delayed shutdown.		
SHORTED OUTPUT ON	-	NO DAMAGE		
OVP TYPE	-	Tracking, Inverter shut-down (automatic reset)		
OVP RANGE	-	Vout*1.15		
OVP RESET TIME	s	Auto Resets 3 times at ~3s interval, then latches off for 1min. Reset cycle is repeated until OVP condition clears.		
FAN FAIL	-	Blocked fan and fan failure detection. Manual reset by input cycling or remote control via the PMBus Interface.		
OTP	-	Yes. Standard: Non-Latch type (automatic reset)		

Table 5

Operating Modes	
Series Operation	Yes
Parallel Operation	Current share single wire (Terminal 1 on Signal Connector), 10% accuracy of max Iout up to 8 units. Power derated 10% of rated. No Oring diodes are required for redundant operation as the power supplies contain internal Oring MOSFETS.

Table 6

DC Output Controls and Indicators	
Output Voltage Adjust	Screwdriver adjustment over entire range. Output voltage range is specified in Table 2. (Multi-turn potentiometer accessible from terminal end of chassis.)
Overcurrent Protection Adjust	Screwdriver adjustable (70% - 105% of max rated current)
DC OK	LED: Green when output >90% of set voltage, Red when fault. LED will turn off when unit enters OTW range.
AC ON	LED: Green when AC is present Blinking RED/GRN when phase dropped (Applicable for 400/480 with 30% Load or greater for TPS400024 and TPS400048. 50% load or greater for TPS400012).

Table 7

Remote Control Features	
Remote Voltage Sensing	Provides precise regulation directly at load. Maximum total DC voltage drop between output terminals and load must be limited to <1.0 V. In addition, the voltage at the output terminals must be limited to the maximum voltage range specified in Table 2.
Remote On/Off Control	On/Off control: Selectable Enable or Inhibit via front panel switch. Switch in the ON position: Unit powers up if PSON left open; Unit in standby mode if PSON shorted to -SNS Switch in the OFF position: Unit in standby mode if PSON left open; Unit powers up if PSON shorted to -SNS PSON High / Low thresholds: 3.0V / 0.6V 12V Maximum allowable. -5V Minimum allowable Signal applied between terminals 14 (PSON) and 18 (-SNS) on Signal Connector.
Remote Analog Voltage Programming	Provides remote adjustment of the output voltage via a DC voltage applied between terminals 3 (VADJ) and 18 (-SNS) on Signal Connector. 0V = V _{out} max, 5V = V _{out} min Adjustments of greater than 1V/Sec can cause Fault conditions Adjustment range changes with adjustment of V _{out} Adj trim pot.
Remote Analog Overcurrent Limit Programming	Provides remote adjustment of the Overcurrent limit via a DC voltage applied between terminals 10 (IADJ) and 18 (-SNS) on Signal Connector. 0V = I _{out} max, 5V = I _{out} min Adjustment range changes with adjustment of I _{LIMIT} Adj trim pot.

Table 8

PMBus Features	
Output Voltage Monitoring	Output voltage monitoring via the PMBus. Accuracy of the voltage reading is +/-2% of full scale
Output Current Monitoring	Output current monitoring via the PMBus. Accuracy of the current reading is +/-10% of full scale
Remote On/Off Control	Supply ON/OFF control via the PMBus
Remote Digital Voltage Programming	Provides remote adjustment of the output voltage via the PMBus interface. Adjustments of greater than 1V/Sec can cause Fault conditions *Settings are not stored after AC source power cycling
Remote Digital Overcurrent Limit Programming	Provides remote adjustment of the Overcurrent limit via the PMBus interface. *Settings are not stored after AC source power cycling

Table 9

Input, Output and Signal Connections	
Input	Heavy Duty terminal block with M4 screws. Grounding terminal included on terminal block.
DC Output	Heavy-duty bus bars with 9mm clearance hole for load connections.
Signal Connector	20 pin signal connector. See Table 11 for pin configuration Recommended mating connector: JST P/N: PHDR-20VS Recommended receptacle contacts: JST P/N: SPHD-001T-P0.5
Address Pin / PMBus Voltage Selector Pin	10 pin connector. Rows 1-4 used for PMBus address selection. Row 5 used to select PMBus Voltage Selection. Open = 5V; Short = 3.3V Recommended shunt jumper: Samtec P/N: 2SN-BK-G
I2C Connector	4 Pin connector: See Table 12 for pin configuration Recommended mating connector: MOLEX P/N: 51110-0460 Recommended receptacle contacts: MOLEX P/N: 50394-8051

Table 10

Signal Connector		
Name	Terminal Location	Description
I _{SHARE}	1	Current share single wire.
I _{OUT}	2	Current monitor signal. 0V = I _{out} min, 5V = I _{out} max. Terminal 18 used for Return.
V _{ADJ}	3	Remote Voltage Programming Terminal. Terminal 18 used for Return.
I _{SHARE}	4	Current share single wire.
OTW	5	Over Temperature Warning Open collector. Non Polarized, 60V peak, Max. sink current: 5mA _{DC} . 2Ω ON resistance, Isolated Terminal 7 used for Return.
+SNS	6	Positive Sense. Used for remote sense connection.
RTN (OTW)	7	Return for Terminal 5
-SNS	8	Negative Sense. Used for remote sense connection. Analog Signals return
PHASE OK	9	Open collector. Max. sink current: 5mA. Off (open) when OK, ON (closed) when input phase missing (Applicable for 400/480 with 30% Load or greater for TPS400024 and TPS400048. 50% Load or greater for TPS400012). Open collector. Non Polarized, 60V peak, Max. sink current: 5mA _{DC} . 2Ω ON resistance, Isolated
I _{ADJ}	10	Provides remote adjustment of the overcurrent limit via an applied DC voltage. 0V = I _{out} max, 5V = I _{out} min Terminal 18 used for Return.
RTN (PHASE OK)	11	Return for Terminal 9
PSON	12	Remote On/Off control. See Remote Control Features section for additional details. Terminal 18 used for Return.
RTN (AC OK)	13	Return for Terminal 15
PSON	14	Remote On/Off control. See Remote Control Features section for additional details. Terminal 18 used for Return.
AC OK	15	On when V _{in} >340Vac AND unit enabled. Turns off 5mS before DC FAIL at nominal V _{out} , 80% of rated load. Open collector. Non Polarized, 60V peak, Max. sink current: 5mA _{DC} . 2Ω ON resistance, Isolated
+SNS	16	Positive Sense. Used for remote sense connection.
DC OK	17	Conducts when V _{out} is greater than 90% of the set output voltage (Tracking) Open collector. Non Polarized, 60V peak, Max. sink current: 5mA _{DC} . 2Ω ON resistance, Isolated
-SNS	18	Negative Sense. Used for remote sense connection. Analog Signals return
RTN (DC OK)	19	Return for Terminal 17
+12V	20	Auxiliary Power Supply: 11.2-12.5V, 0-0.3A. Less than 200mVp-p ripple and noise.

Table 11

PMBus Connections		
Name	Terminal Location	Description
SMB ALERT	4	Interrupt Line for I2C
SMB GND	3	Return for I2C
SCL	2	Clock Line for I2C
SDA	1	Data Line for I2C

Table 12

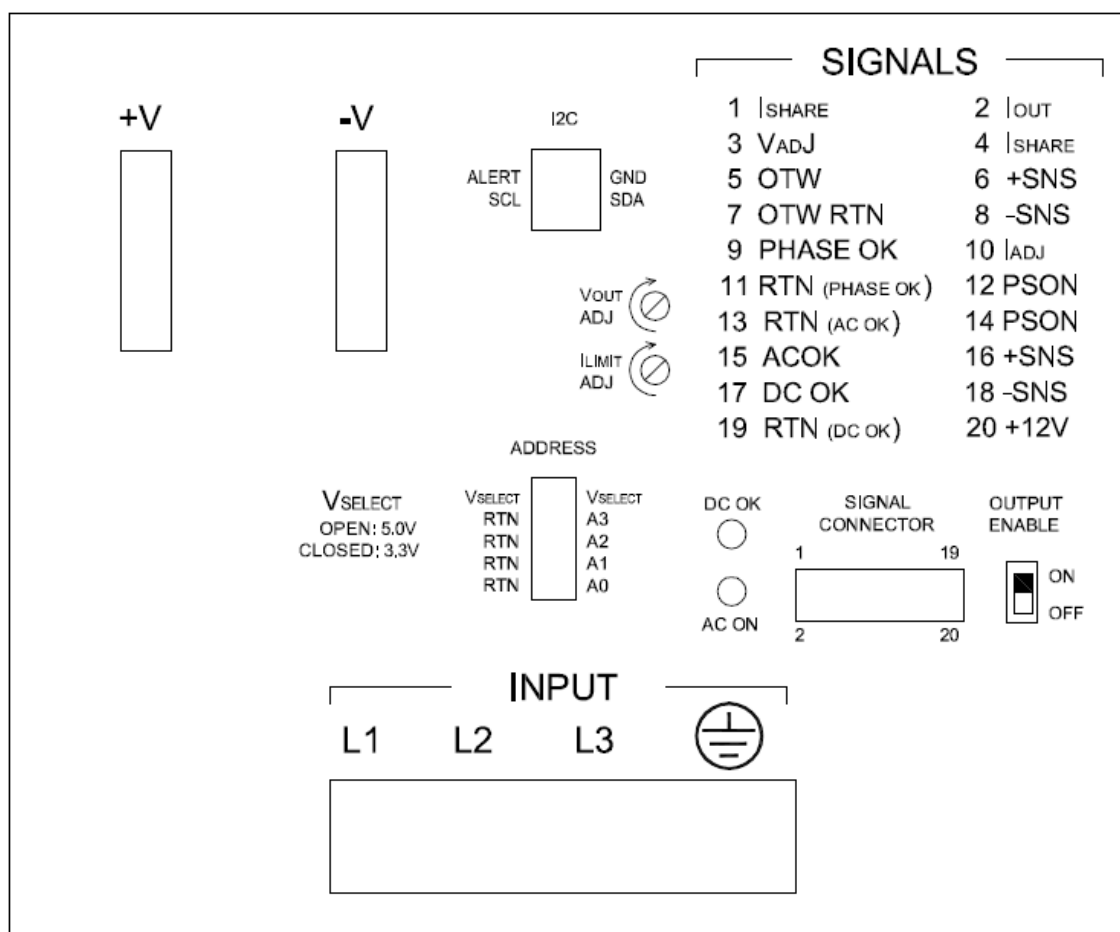

Figure 1: Pin assignments

Local Sense Setup

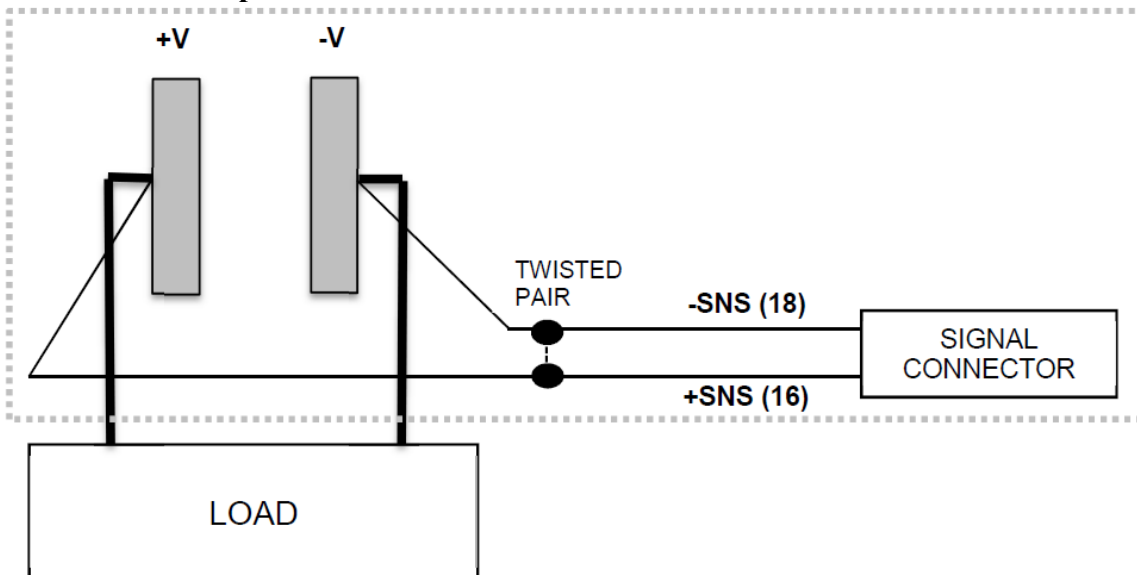

Figure 2: Typical Local Sense Connection

Remote Sense Setup

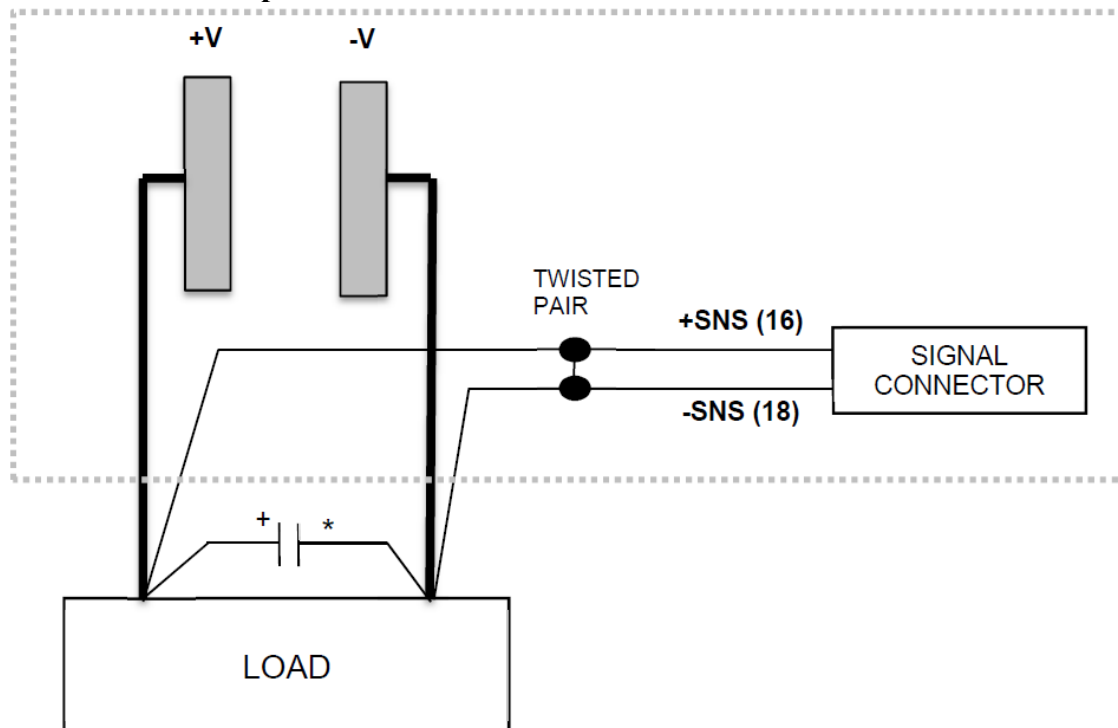

Figure 3: Typical Remote Sense Connection

* Suitable Decoupling Capacitor (0.1 μ F or higher) may be required at load.

Parallel Operation Setup

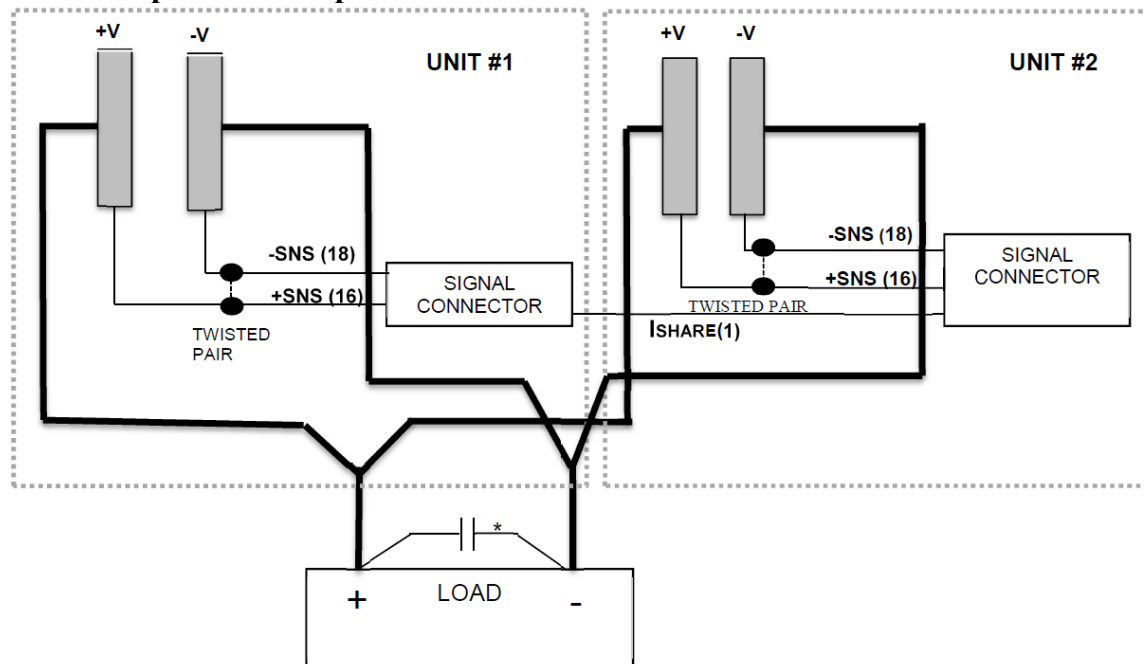

Figure 4: Parallel Operation (Local Sensing)

*Suitable Decoupling Capacitor (0.1uF or higher) may be required at load.

For optimal performance, power supplies should have their output voltages set to within 1% of each other

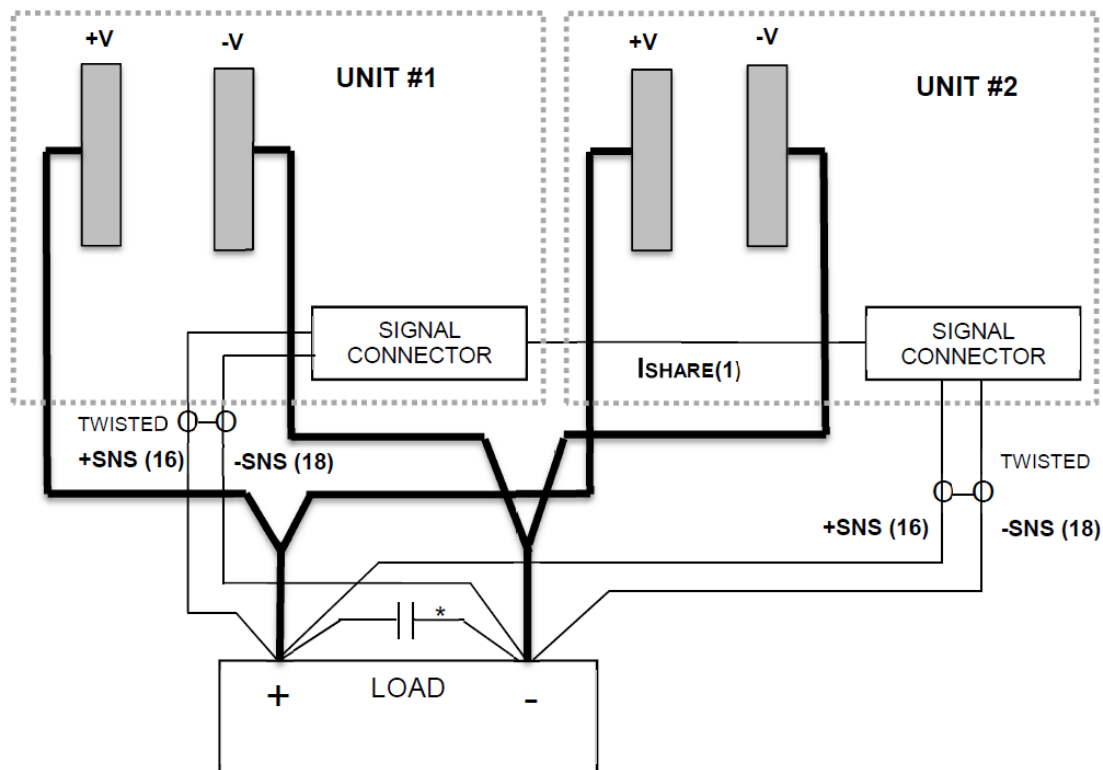

Figure 5: Parallel Operation (Remote Sensing)

*Suitable Decoupling Capacitor (0.1 μ F or higher) may be required at load.

For optimal performance, power supplies should have their output voltages set to within 1% of each other

Series Operation Setup

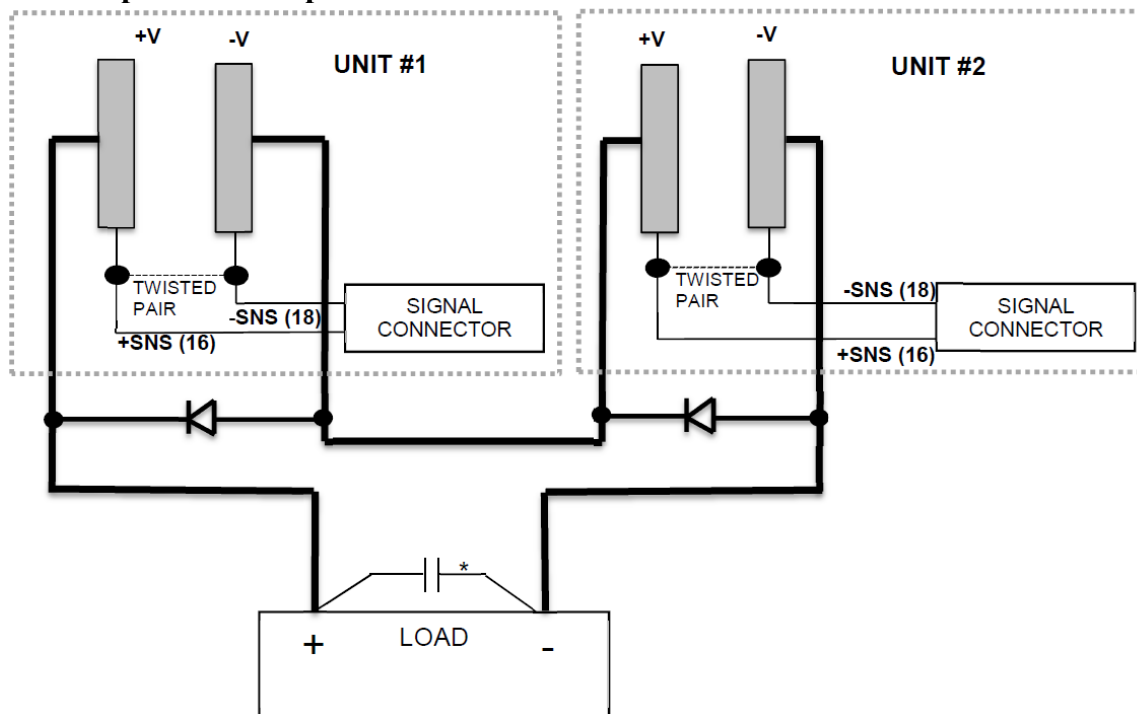

Figure 6: Series Operation (Local Sensing)

*Suitable Decoupling Capacitor (0.1uF or higher) may be required at load.

Note: It is recommended that diodes rated a minimum of 25V be used for any TPS4000-12 units operated in series, a minimum of 50V be used for any TPS4000-24 units operated in series and a minimum of 100V be used for any TPS4000-48 operated in series.

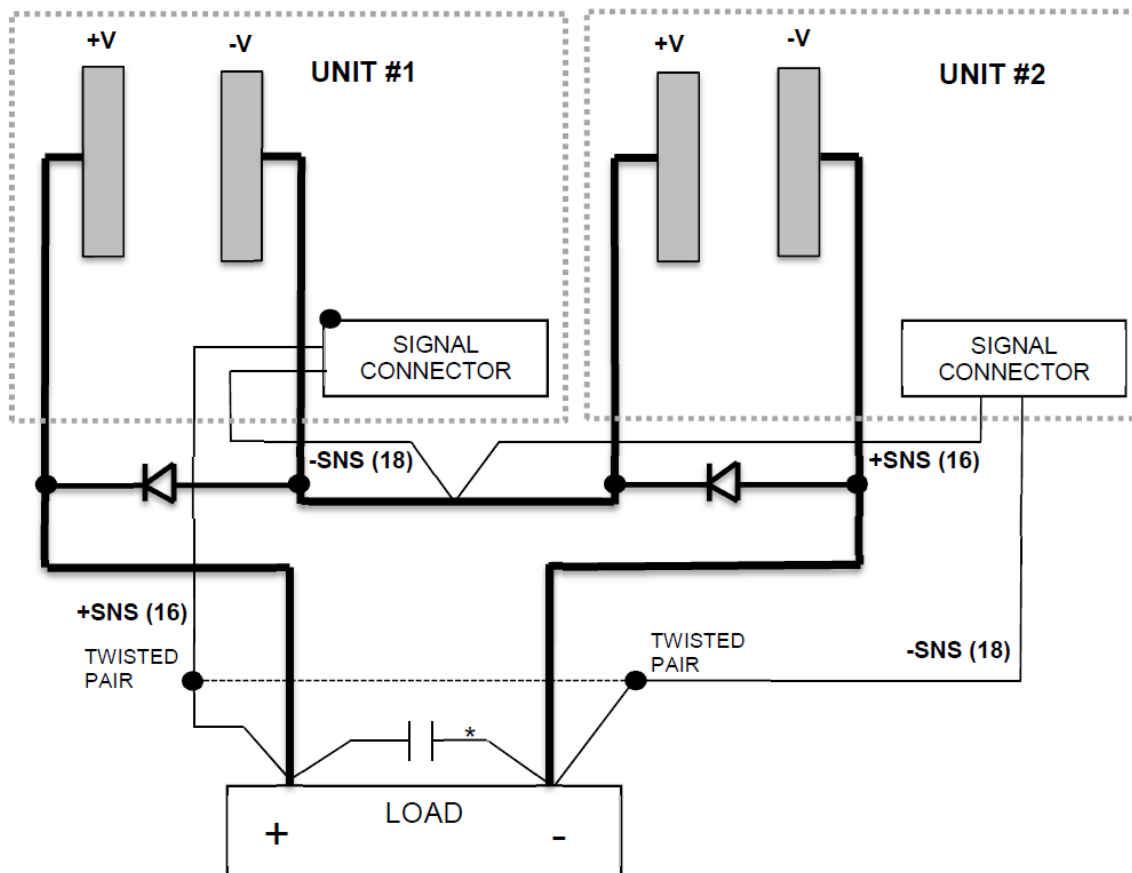

Figure 7: Series Operation (Remote Sensing)

*Suitable Decoupling Capacitor (0.1uF or higher) may be required at load.

Note: It is recommended that diodes rated a minimum of 25V be used for any TPS4000-12 units operated in series, a minimum of 50V be used for any TPS4000-24 units operated in series and a minimum of 100V be used for any TPS4000-48 operated in series.

DO NOT CONNECT THE SENSE WIRES IN PARALLEL DURING SERIES OPERATION – THIS MAY RESULT IN DAMAGE TO THE POWER SUPPLY.

Ripple and Noise Notes

Ripple and Noise is measured according to the description below in accordance with JEITA RC-9131C (Sections 7.16, 7.17 and 7.18).

The measurement connection is shown in Fig. 3-1.

C1 (0.1 μ F Ceramic Capacitor), C2 (47 μ F Aluminum Electrolytic Capacitor) must be connected in parallel at 30cm from the output terminals, along the load cable. Attach a maximum 1.5m 50 Ω coaxial cable from the ceramic capacitor electrodes to a filter attachment installed on the oscilloscope. The filter attachment consists of C3 (4700pF film capacitor) in series with R (50 Ω resistor). Use 100MHz bandwidth oscilloscope or equivalent.

In general, output ripple voltage and output spike noise voltage can be reduced by increasing external capacitance.

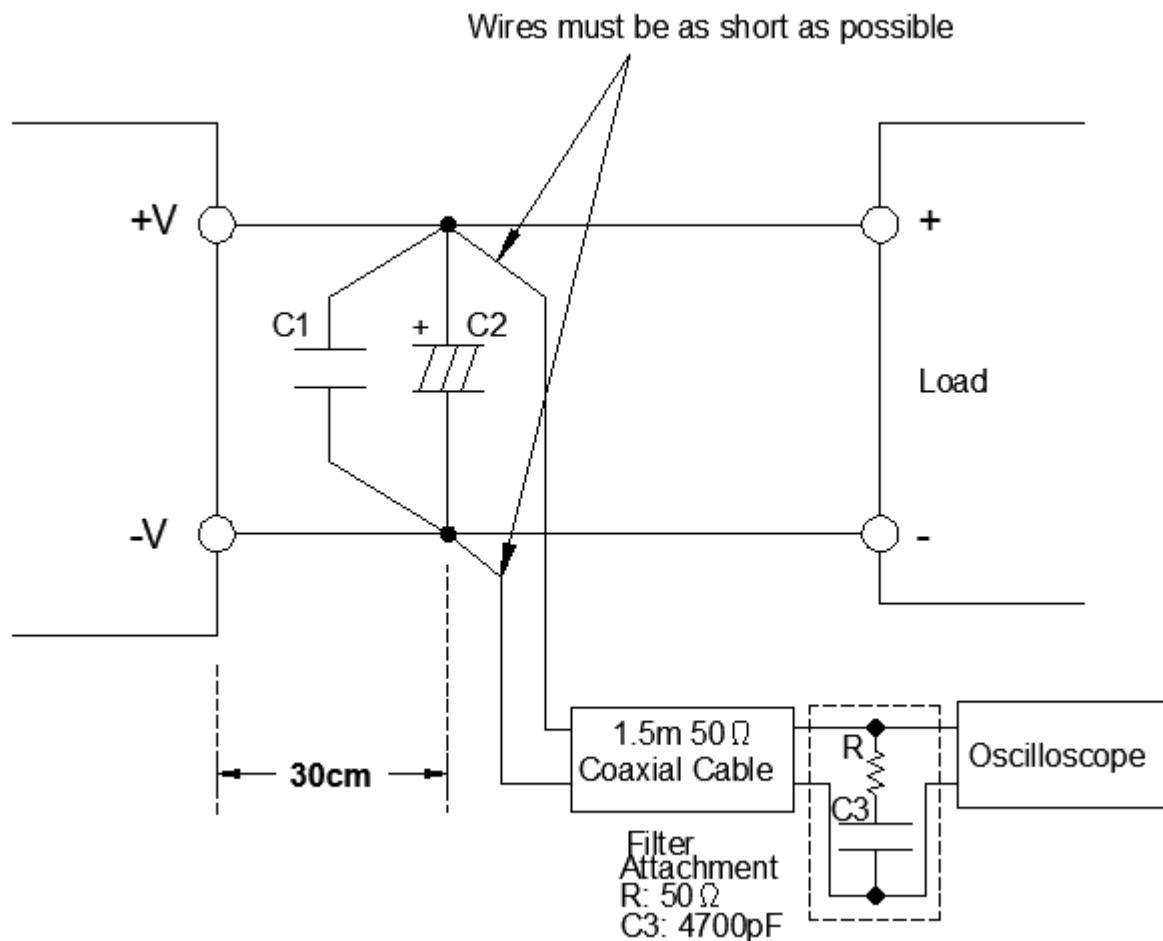
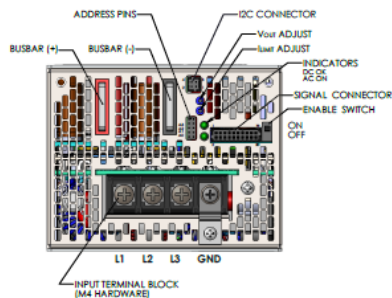
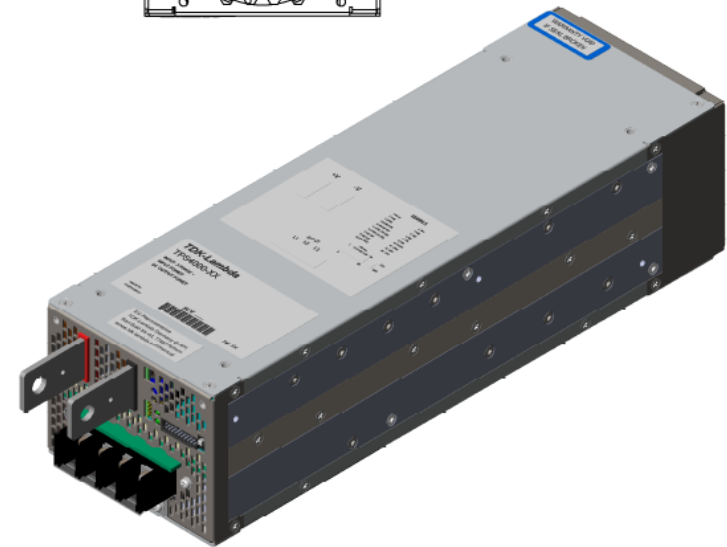
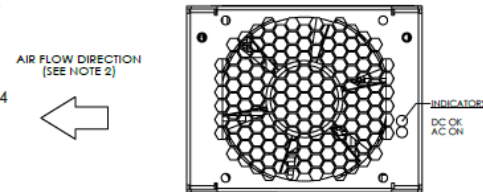
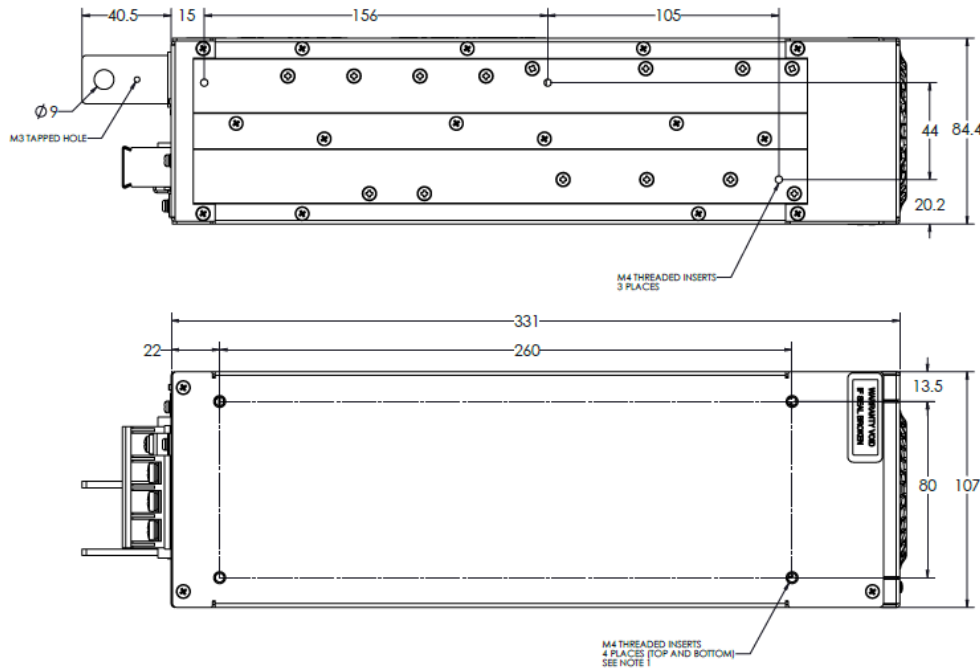

Figure 8: Output Ripple Voltage (including Spike Noise) Measurement Method

Mechanical Drawing

Overall dimensions for the TPS4000 series are shown below:



I2C CONNECTOR		SIGNAL CONNECTOR	
PIN No.	FUNCTION	PIN No.	FUNCTION
1	SDA	2	IN+12V
2	SCL	3	IN+5V
3	SMB GND	4	IN+5V
4	SMB ALERT	5	OT
		6	+5V
		7	SND (SIGNAL)
		8	-SMB
		9	FIXASE OK
		10	IN+5V
		11	RTN (PHASE OK)
		12	PSON
		13	RTN (AC OK)
		14	PSON
		15	ACOK
		16	+5V
		17	DC OK
		18	-SMB
		19	RTN (DC OK)
		20	+12V

ADDRESS PINS	
PIN	FUNCTION
1	V _{ADJUST} / V _{OUT}
2	ADJ
3	ADJ
4	ADJ

V_{ADJUST} CLAMP 15V

- NOTES:
1. MOUNTING SCREWS MUST NOT PROTRUDE INTO THE POWER SUPPLY MORE THAN 6mm
 2. ALLOW A MINIMUM OF 50mm UNRESTRICTED AIR SPACE AT THE REAR OF THE UNIT. DO NOT OBSTRUCT AIR FLOW TO THE UNIT FRONT PANEL.
 3. SIGNAL CONNECTOR RECEPTACLE: JST P/N: PHDR-20VS
RECEPTACLE CONTACTS: JST P/N: SPHD-001T-P0.5
 4. I2C CONNECTOR RECEPTACLE: MOLEX P/N: 51110-0460
RECEPTACLE CONTACTS: MOLEX P/N: 50394-8051
 5. ADDRESS PIN SELECTOR SHUNT JUMPER: SAMTEC P/N: 25N-BK-G

TPS4000-XX

PMBus™ Interface

The TPS4000 has Power Management Bus (PMBus) hardware.

The PMBUS interface in the TPS4000 includes:

- Monitoring the Output Voltage (+/- 2% of Full Scale).
- Monitoring the Output Current (+/- 10% of Full Scale).
- Monitoring the internal Temperature (works on +40°C to 106° C range. Above 106°C the OTP activates and the monitor reads >180°C).
- Programming the Output Voltage (+/- 2% of Full Scale).
- Programming the Current Limit.
- Programming the Supply ON/OFF state.
- Reading and Clearing Faults.
- Reading the Manufacturing Related Data (Model Name, Serial No, Manufacturing Date, etc).

ATTENTION:

The PMBus supports:

- 100 KHz Operation.
- Block Read Protocol.
- Group Command Protocol.
- Direct Command Format for Monitoring and Programming
- Functions. Ver. 1.1 of PMBus Specifications.

ADDRESSING (A3, A2, A1, A0 inputs)

To communicate with the TPS4000, the master must first address the slave devices via a slave address byte. The slave address byte consists of seven address bits and a direction bit that indicates the intent to execute a read or write operation.

The TPS4000 features four variable address lines that allow up to 16 Supplies to be connected on a single bus.

PMBus uses 7 bit addressing. There is constant part of address and variable part of address:

Constant part of address consists of 3 Most Significant Bits A6, A5, and A4 and always equals 010.

Variable part of address consists of 4 Least Significant bits: A3, A2, A1, and A0.

Values of these four bits have to be assigned by hardware connections of 4 pins of the TPS4000 address connector.

The Address lines (A3, A2, A1, and A0) are internally pulled up by resistors to +5V.

The Address lines can be left open for <1> address or connected for <0> address.

There are 16 possible addresses: from 0100000 to 0101111.

In case more than one TPS4000 is connected to PMBus, each unit must be set to its own unique address. Duplicate addressing is not allowed.

A6	A5	A4	A3	A2	A1	A0	R/W Byte	Hex Address
0	1	0	0	0	0	0	x	40h
0	1	0	0	0	0	1	x	42h
0	1	0	0	0	1	0	x	44h
0	1	0	0	0	1	1	x	46h
0	1	0	0	1	0	0	x	48h
0	1	0	0	1	0	1	x	4Ah
0	1	0	0	1	1	0	x	4Ch
0	1	0	0	1	1	1	x	4Eh
0	1	0	1	0	0	0	x	50h
0	1	0	1	0	0	1	x	52h
0	1	0	1	0	1	0	x	54h
0	1	0	1	0	1	1	x	56h
0	1	0	1	1	0	0	x	58h
0	1	0	1	1	0	1	x	5Ah
0	1	0	1	1	1	0	x	5Ch
0	1	0	1	1	1	1	x	5Eh

Table 13

Factory default Address is 5Eh.

SERIAL CLOCK

This line is clocked by the Controller which controls the PMBUS. It is connected to +5.0V (referenced to "SMB_GND") via a 5.0kΩ pull-up resistor.

SERIAL DATA

This is a Bi-Directional line which is connected to +5.0V (referenced to "SMB_GND") via a 5.0kΩ pull up resistor.

ALERT

ALERT is used to indicate to the HOST about any Faults/Error/Warning Conditions.

This line is connected to +5.0V (referenced to "SMB_GND") via a 2.49kΩ pull up resistor.

This Signal is HIGH to indicate that no fault/error/warning is present. If some fault/error/warning occurs, the signal will go LOW.

The Host system must poll multiple supplies after receiving ALERT to retrieve fault/error/warning information.

Note: The TPS4000 does not respond to Alert Response Address.

PMBus™ COMMAND SET

OPERATION (ON/OFF)

If the Power Supply is turned OFF with the “OPERATION OFF” command, the Supply can be turned ON with the “OPERATION ON” command.

Command code	Type	Data sent
01h	R/W Byte	00h=OFF
01h	R/W Byte	80h=ON

Table 14

After applying AC power to the unit the default control mode is the “*Local Mode*”. In this Mode the Front Panel Output Enable Switch will control the output state.

To turn ON or OFF the Unit in “*Remote Mode*” (I2C) you need to do the follow:
Set Operation Mode to “*Remote Mode*”.
Then issue “*Operation ON*” to turn ON or “*Operation OFF*” to turn OFF the unit.

Once you enter “*Remote Mode*” the Front Panel Output Enable Switch has no longer control of the Output until you change over to “*Local Mode*”.

Attention: If the unit is ON and you issue “*Operation OFF*” followed by “*Operation ON*” command within 3.0 Sec, the Unit will remain in the OFF state for 3.0 Sec from the time you issue the “*Operation OFF*” command.
Also in Local Mode the Front Panel Output Enable Switch will behave in the same way. If the unit was enabled and you disable it follow by Enable within 3.0 Sec, the Unit will remain in the OFF state for 3.0 Sec from the time you disabled the unit.

When you switch from “*Local Mode*” to “*Remote Mode*” for first time after applying AC power the default Operation State will be “*Operation ON*”.

However, if you try to change Operation State before you change Operation Mode to “*Remote Mode*” the unit will respond with error and will ignore the command.

If you need the Unit OFF when you enter “*Remote Mode*” you need to issue “*Operation OFF*” command right after entering “*Remote Mode*”.

OPERATION MODE

This command is used to set the way you Enable/Disable the output of the Unit. Setting the Operation Mode to “*Remote Mode*” allow you to control the output using the “OPERATION ON/OFF” command via the I2C. In the “*Local Mode*” you have the option to use the Front Panel Output Enable Switch or the “PSON” pin on the Signals connector.

Command code	Type	Data sent
D8h	R/W Byte	00h=Remote
D8h	R/W Byte	80h=Local

Table 15

PROGRAMMING MODE

This command is used to set the way you adjust the output of the Unit. Setting the Programming Mode to “*Remote*” allows you to program the output voltage and current limit using the I2C commands. In the “*Local*” you have the option to use the Front Panel Vout ADJ trim pot or the “Vadj” pin on the Signals connector to adjust the output voltage and the “Iadj.” trim pot to adjust the current limit point.

Command code	Type	Data sent
D2h	R/W Byte	00h=Remote
D2h	R/W Byte	80h=Local

Table 16

CLEAR FAULTS

This command is used to clear any fault bits that have been set in the “STATUS REGISTER”.

If the CLEAR_FAULTS command is not sent after any fault occurs, the “STATUS REGISTER” will not be cleared.

ALERT signal will remain “LOW” until a “CLEAR_FAULTS” command is sent.

If a Fault or Warning is still present after “CLEAR_FAULTS” is sent, “STATUS REGISTER” will be updated and the ALERT signal will be “LOW” again.

Command code	Type	#Data bytes
03h	Send Byte	0

Table 17

COMMANDS TO READ INVENTORY DETAILS

The commands bellow will retrieve the inventory data stored in the units EEPROM.

Command Name	Command code	Type	#Data bytes
PMBUS_REVISION	98h	Read Byte	1
MFR_ID	99h	Read Block	10
MFR_MODEL	9Ah	Read Block	10
MFR_REVISION	9Bh	Read Block	11
MFR_LOCATION	9Ch	Read Block	3
MFR_DATE	9Dh	Read Block	8
MFR_SERIAL	9Eh	Read Block	20

Table 18

All details except for <PMBUS_REVISION> are stored in ASCII format.

READ STATUS

This Command is used to read the status of the Power Supply. The Status information is stored in a special register called the “STATUS REGISTER”.

The PMBus reads 16 different types of Faults and Warnings.

Command Used	Type	#Data bytes
D0h	Read Word	2

Table 19

Fault is indicated by “1” -ONE-. No fault is indicated by “0” -ZERO-.

For Example: If DC Status occurs, READ_STATUS will return 01h. ALERT will go “LOW”

Faults	Type	Bit # in Status Register	Meaning	Main output behavior
Low Byte				
DCOK	FAULT	0	Output Voltage < 85~95% of Set Vout	Output ON or OFF
 	 	1	 	
OVP	FAULT	2	Output Voltage > 1.15xVset	Output OFF
OTP	FAULT	3	Internal temperature higher than safe limit	Output OFF
OTW	WARNING	4	Internal temperature ~ 10°C below OTP limit.	Output ON
FANOK	WARNING	5	Fan is rotating slow	Output OFF
ACOK	FAULT	6	Input Voltage < 250Vac	Output OFF
PHOK	WARNING	7	One Input Phase Low or Out	Output ON
High Byte				
Vo _{max} Limit	WARNING	0	Vo _{prog.} greater than Vo _{max} Limit	Output ON
IDR	WARNING	1	Invalid Data Byte Received	Output ON
IPM	WARNING	2	Invalid Programming Mode	Output ON
IOM	WARNING	3	Invalid Operating Mode	Output ON
I2C_BE	WARNING	4	Buss Error	Output ON
ICPDR	WARNING	5	Invalid Current Prog. Data Received	Output ON
IVPDR	WARNING	6	Invalid Voltage Prog. Data Received	Output ON
ICR	WARNING	7	Invalid Command Received	Output ON

Table 20

PROGRAMMING AND MONITORING FUNCTIONS

For Monitoring and Programming functions use the following equation

$$Y = (mX + b) * 10^R \quad X = (Y * 10^{-R} - b) / m$$

Where:

Y is the digital value sent or received from the supply.

X is the actual value (V, A, °C)

m, b, R - coefficients that are explained in Table 1.

Voltage (V)	Physical value	Physical	Min. Value	Max. Value	m	b	R
48	Voltage Programming	V	16	58	6947	-3882	-2
	Voltage monitoring	V	0	60	1665	-673	-2
	Current Programming	A	50	87	4636	-18214	-2
	Current monitoring	A	0	108	9542	-11916	-3
	Temperature monitoring	°C	-40	150	21	5554	-1
24	Voltage Programming	V	8	29	13793	-4251	-2
	Voltage monitoring	V	0	30	3413	-1069	-2
	Current Programming	A	84	175	2275	-13848	-2
	Current monitoring	A	0	200	4696	3005	-3
	Temperature monitoring	°C	-40	150	21	5554	-1
12	Voltage Programming	V	8	29	13793	-4251	-2
	Voltage monitoring	V	0	30	3413	-1069	-2
	Current Programming	A	84	175	2235	4195	-2
	Current monitoring	A	0	200	4696	3005	-3
	Temperature monitoring	°C	-40	150	21	5554	-1

Table 21

m, b, R coefficients can also be recovered from the EEPROM coefficients are stored in ASCII Format.

Command name	Command code	Type	#Data bytes
MFR_VOLTAGE_MON_COEFF	D3h	Read Block	18
MFR_VOLTAGE_PROG_COEFF	D4h	Read Block	18
MFR_CURRENT_MON_COEFF	D5h	Read Block	18
MFR_CURRENT_PROG_COEFF	D6h	Read Block	18
MFR_TEMP_MON_COEFF	D7h	Read Block	18

Table 22

MONITORING THE OUTPUT VOLTAGE (READ_VOUT)

The accuracy of the voltage reading is +/-2%

The output voltage is read before the ORING Circuit (~50mV Voltage drop @ load, no drop @no load). The read back Output Voltage can be calculated using the “Direct data Format”.

Refer to **Table 1** for the Coefficients for calculating the Output Voltage.

Command code	Type	#Data bytes
8Bh	Read Word	2

Table 23

Example: TPS4000-24.

Hex read back = 0328 h.

Converted to Decimal = 808.

Using the required coefficients the Output Voltage $((808*100)+1069)/3413 = 23.99V$.

Read the Actual Output Voltage on the Output Bus Bar (Ex: 24.00V).

Add 0.05V to compensate ORING Circuit drop. So, the actual voltage is (Ex: $23.99 + 0.05 = 24.04V$).

MONITORING THE OUTPUT CURRENT (READ_IOUT)

The accuracy of the current reading is +/-10%

The read back output current can be calculated using the “Direct data Format”. Refer to **Table 1** for the Coefficients for calculating the Output Current.

Command Used	Type	#Data bytes
8Ch	Read Word	2

Table 24

Example: TPS4000-24.

Hex read back = 0250h.

Converted to Decimal = 592.

Using the required coefficients the output current = $((592*1000)-3005)/4696 = 125.42A$.

MONITORING THE SUPPLY TEMPERATURE (READ_TEMPERATURE_1)

The accuracy of the Temperature reading is +/-3 C

The read back supply temperature can be calculated using the “Direct data Format”.

Please refer to **Table 1** for the Coefficients for calculating the Supply Temperature.

Command Used	Type	#Data bytes
8Dh	Read Word	2

Table 25

Example:

Hex read back = 02FAh;

Converted to Decimal = 762;

Using the required coefficients the Supply Internal Temperature = $((762*10)-5554)/21 = 98.38^{\circ}C$.

PROGRAMMING THE OUTPUT VOLTAGE (VOUT_COMMAND)

The accuracy of the Output Voltage Programming is +/-2%

The output Voltage can be programmed using the “Direct data Format”.

Please refer to table 1 for the Coefficients to be used for calculating the Voltage Programming.

Command Used	Type	#Data bytes
21h	R/W Word	2

Table 26

Example: TPS4000-24.

To program the Output Voltage to 24V, send $((24 * 13793) - 4251) * 0.01 = 3267$ (DEC) and Converted to Hex = 0CC3h.

PROGRAMMING THE OUTPUT CURRENT LIMIT (IOUT_COMMAND)

The output current Limit can be programmed using the “Direct data Format”.

Please refer to table 1 for the Coefficients to be used for calculating the Voltage Programming.

Command Used	Type	#Data bytes
D1h	R/W Word	2

Table 27

Example: TPS4000-24.

To program the Output Current Limit to 100A, send $((100 * 2275) - 13848) * 0.01 = 2137$ (DEC) and Converted to Hex = 0859h.

PROGRAMMING THE MAXIMUM ALLOWABLE OUTPUT VOLTAGE (VOUT_MAX_COMMAND)

The VOUT_MAX command sets an upper limit on the output voltage the unit can command regardless of any other commands or combinations. The intent of this command is to provide a safeguard against a user accidentally setting the output voltage to a possibly destructive level rather than to be the primary output overprotection.

If an attempt is made to program the output voltage higher than the limit set by this command, the unit will set the output voltage to VOUT_MAX, the “IVPDR” (Invalid Voltage Prog. Data Received) bit will be set in the STATUS_BYTE and will notify the host.

The accuracy of the Vmax Programming is +/-2%

The VOUT_MAX can be programmed using the “Direct Data Format”.

Please refer to table 1 for the Coefficients to be used for calculating the Vomax Programming.

Command Used	Type	#Data bytes
24h	R/W Word	2

Table 28

Example: TPS4000-24.

To program the Vomax to 25.5V, send $((25.5 * 13793) - 4251) * 0.01 = 3475$ (DEC) and Converted to Hex = 0D93h.