

SWT40 - *

RELIABILITY DATA

DWG. NO. CA702--79--01			
APPROVED	APPROVED	CHECKED	ENGR.
<i>T. Murayama</i>	<i>K. N. G.</i>	<i>孙斌</i> Nov. 2, 1995	<i>许正</i>
<i>29/DEC/95</i>	<i>2-Nov-95</i>		<i>5/sep/95</i>

INDEX

1. M.T.B.F.	T - 1
2. Components Derating	T - 2
3. ΔT Temperature Rise	T - 5
4. E - cap. Lifetime versus Load	T - 7
5. Abnormal Test	T - 17
6. Vibration Test	T - 20
7. Noise Simulation Test	T - 22
8. Electrostatic Discharge Test	T - 23
9. Lightning surge Test	T - 24

The above data is typical value. As all units have nearly the same characteristics, the data to be considered as ability value.

SWT40 - *

M.T.B.F.

1. Method of calculation

Calculated based on part count reliability projection of MIL-HDBK-217F.

Individual failure rates λ_G is given to each part and M.T.B.F. is calculated by the count of each part.

Formula :

$$\begin{aligned} \text{M.T.B.F.} &= \frac{1}{\lambda_{\text{equip}}} \\ &= \frac{1}{\sum_{i=1}^n N_i (\lambda_G \pi_Q)_i} \quad (\text{HOURS}) \end{aligned}$$

Where :

λ_{equip} = Total Equipment Failure Rate (Failures/10⁶ Hours)

λ_G = Generic Failure Rate For The ith Generic Part (Failure/10⁶ Hours)

N_i = Quantity of ith Generic Part

n = Number of Different Generic Part Categories

π_Q = Generic Quality factor for the ith Generic Part ($\pi_Q = 1$)

2. M.T.B.F. Values

G_F : (GROUND, FIXED)

M.T.B.F. = 493,949 (HOURS)

COMPONENT DERATING

(At nominal Line and Rated Load , Ambient Temperature 50°C)

Method of calculation

A. Semiconductors

The derating factor is taken as the ratio of the actual operating junction temperature taking into consideration operating ambient temperature , power loss and thermal resistance to the maximum rated junction temperature specifications of the components.

B. IC, Resistors, Capacitors etc.

Operating ambient temperature, operating condition, power loss for each individual component are all designed to meet the requirements of Nemic - Lambda's design standard.

C. Thermal Resistance Calculation

$$R_{th(j-c)} = \frac{T_j(\max) - T_c}{P_d(\max)}, \quad R_{th(j-a)} = \frac{T_j(\max) - T_a}{P_d(\max)}$$

T_c : Case Temperature (Normally 25°C)

T_a : Ambient Temperature (Normally 25°C)

$P_d(\max)$: Maximum Power Loss

$T_j(\max)$: Maximum Junction temperature

$R_{th(j-c)}$: Junction to Case Thermal Resistance

$R_{th(j-a)}$: Junction to Ambient Thermal Resistance

SEMICONDUCTOR DERATING

MODEL No. : SWT40 - 522

MOUNTING: A $V_{in} = 100VAC$ LOAD = 100% $T_a = 50^{\circ}C$

A1 PWR-TOP204YAI P.I.	$T_{jmax} = 150^{\circ}C$	$R_{th(j-c)} = 2.0^{\circ}C/W$	$Pd(max) = --W$
	$Pd = 4.04W$	$dT_c = 58.2^{\circ}C$	$T_c = 108.2^{\circ}C$
	$T_j = 117.0^{\circ}C$		
	D.F. = 78.0%		
A2 KA7812 SAMSUNG	$T_{jmax} = 125^{\circ}C$	$R_{th(j-c)} = 5.00^{\circ}C/W$	$Pd(max) = 2W$
	$Pd = 1.47W$	$dT_c = 56.4^{\circ}C$	$T_c = 106.4^{\circ}C$
	$T_j = 113.7^{\circ}C$		
	D.F. = 90.9%		
A3 KA431Z SAMSUNG	$T_{jmax} = 150^{\circ}C$	$R_{th(j-c)} = 156.25^{\circ}C/W$	$Pd(max) = 0.70W$
	$Pd = 0.012W$	$dT_c = 40.6^{\circ}C$	$T_c = 90.6^{\circ}C$
	$T_j = 92.5^{\circ}C$		
	D.F. = 61.7%		
D1 D3SB60 SHINDENGEN	$T_{jmax} = 150^{\circ}C$	$R_{th(j-c)} = 5.5^{\circ}C/W$	$Pd(max) = --W$
	$Pd = 1.04W$	$dT_c = 56.9^{\circ}C$	$T_c = 106.9^{\circ}C$
	$T_j = 112.6^{\circ}C$		
	D.F. = 75.1%		
D2 G11003 G.I.	$T_{jmax} = 175^{\circ}C$	$R_{th(j-l)} = 20^{\circ}C/W$	$Pd(max) = --W$
	$Pd = 0.08W$	$dT_l = 40.2^{\circ}C$	$T_l = 90.2^{\circ}C$
	$T_j = 91.8^{\circ}C$		
	D.F. = 52.5%		
D3 1NU41 TOSHIBA	$T_{jmax} = 150^{\circ}C$	$R_{th(j-l)} = 50^{\circ}C/W$	$Pd(max) = --W$
	$Pd = 0.0034W$	$dT_l = 48.7^{\circ}C$	$T_l = 98.7^{\circ}C$
	$T_j = 98.9^{\circ}C$		
	D.F. = 65.9%		
D4 D10SC6M SHINDENGEN	$T_{jmax} = 125^{\circ}C$	$R_{th(j-c)} = 3.3^{\circ}C/W$	$Pd(max) = --W$
	$Pd = 0.54W$	$dT_c = 44.4^{\circ}C$	$T_c = 94.4^{\circ}C$
	$T_j = 96.2^{\circ}C$		
	D.F. = 77.0%		
D6 D10SC4M SHINDENGEN	$T_{jmax} = 125^{\circ}C$	$R_{th(j-c)} = 3.3^{\circ}C/W$	$Pd(max) = --W$
	$Pd = 1.3W$	$dT_c = 55.2^{\circ}C$	$T_c = 105.2^{\circ}C$
	$T_j = 109.5^{\circ}C$		
	D.F. = 87.6%		
ZD1 P6KE220CA G.I.	$T_{jmax} = 175^{\circ}C$	$R_{th(j-l)} = 20.0^{\circ}C/W$	$Pd(max) = --W$
	$Pd = --W$	$dT_l = 48.9^{\circ}C$	$T_l = 98.9^{\circ}C$
	$T_j = 98.9^{\circ}C$		
	D.F. = 51.5%		
PC1(LED) 4N35TV MOTOROLA	$T_{jmax} = 125^{\circ}C$	$R_{th(j-c)} = --^{\circ}C/W$	$Pd(max) = --W$
	$I_f = 0.970mA$		
	$I_{fmax} = 24mA$	$T_a = 81.6^{\circ}C$	
	D.F. = 4%		
PC1(TR.) 4N35TV MOTOROLA	$T_{jmax} = 125^{\circ}C$	$R_{th(j-c)} = 568.2^{\circ}C/W$	$Pd(max) = --W$
	$Pd = 0.0052W$	$dT_c = 31.6^{\circ}C$	$T_c = 81.6^{\circ}C$
	$T_j = 84.4^{\circ}C$		
	D.F. = 67.9%		

SEMICONDUCTOR DERATING

MODEL No. : SWT40 - 522

MOUNTING: A $V_{in} = 200VAC$ LOAD = 100% $T_a = 50^{\circ}C$

A1 PWR-TOP204YAI P.I.	$T_{jmax} = 150^{\circ}C$	$R_{th(j-c)} = 2.0^{\circ}C/W$	$Pd(max) = --W$
	$Pd = 1.63W$	$dT_c = 52.5^{\circ}C$	$T_c = 102.5^{\circ}C$
	$T_j = 105.8^{\circ}C$		
	D.F. = 70.5%		
A2 KA7812 SAMSUNG	$T_{jmax} = 125^{\circ}C$	$R_{th(j-c)} = 5.00^{\circ}C/W$	$Pd(max) = 2W$
	$Pd = 1.47W$	$dT_c = 52.1^{\circ}C$	$T_c = 102.1^{\circ}C$
	$T_j = 109.4^{\circ}C$		
	D.F. = 87.5%		
A3 KA431Z SAMSUNG	$T_{jmax} = 150^{\circ}C$	$R_{th(j-c)} = 156.25^{\circ}C/W$	$Pd(max) = 0.70W$
	$Pd = 0.012W$	$dT_c = 38.3^{\circ}C$	$T_c = 88.3^{\circ}C$
	$T_j = 90.2^{\circ}C$		
	D.F. = 60.1%		
D1 D3SB60 SHINDENGEN	$T_{jmax} = 150^{\circ}C$	$R_{th(j-c)} = 5.5^{\circ}C/W$	$Pd(max) = --W$
	$Pd = 0.52W$	$dT_c = 35.6^{\circ}C$	$T_c = 85.6^{\circ}C$
	$T_j = 88.5^{\circ}C$		
	D.F. = 59.0%		
D2 GI1003 G.I.	$T_{jmax} = 175^{\circ}C$	$R_{th(j-l)} = 20^{\circ}C/W$	$Pd(max) = --W$
	$Pd = 0.08W$	$dT_l = 37.4^{\circ}C$	$T_l = 87.4^{\circ}C$
	$T_j = 89.0^{\circ}C$		
	D.F. = 51.0%		
D3 1NU41 TOSHIBA	$T_{jmax} = 150^{\circ}C$	$R_{th(j-l)} = 50^{\circ}C/W$	$Pd(max) = --W$
	$Pd = 0.018W$	$dT_l = 41.4^{\circ}C$	$T_l = 91.4^{\circ}C$
	$T_j = 92.3^{\circ}C$		
	D.F. = 61.5%		
D4 D10SC6M SHINDENGEN	$T_{jmax} = 125^{\circ}C$	$R_{th(j-c)} = 3.3^{\circ}C/W$	$Pd(max) = --W$
	$Pd = 0.54W$	$dT_c = 42.9^{\circ}C$	$T_c = 92.9^{\circ}C$
	$T_j = 98.1^{\circ}C$		
	D.F. = 78.5%		
D6 D10SC4M SHINDENGEN	$T_{jmax} = 125^{\circ}C$	$R_{th(j-c)} = 3.3^{\circ}C/W$	$Pd(max) = --W$
	$Pd = 1.3W$	$dT_c = 50.1^{\circ}C$	$T_c = 100.4^{\circ}C$
	$T_j = 104.7^{\circ}C$		
	D.F. = 84.0%		
ZD1 P6KE220CA G.I.	$T_{jmax} = 175^{\circ}C$	$R_{th(j-l)} = 20.0^{\circ}C/W$	$Pd(max) = --W$
	$Pd = --W$	$dT_l = 36.3^{\circ}C$	$T_l = 86.3^{\circ}C$
	$T_j = 86.3^{\circ}C$		
	D.F. = 49.3%		
PC1(LED) 4N35TV MOTOROLA	$T_{jmax} = 125^{\circ}C$	$R_{th(j-c)} = --^{\circ}C/W$	$Pd(max) = --W$
	$I_f = 0.97mA$		$T_a = 50^{\circ}C$
	$I_{fmax} = 24mA$	$T_a = 81.2^{\circ}C$	
	D.F. = 4%		
PC1(TR.) 4N35TV MOTOROLA	$T_{jmax} = 125^{\circ}C$	$R_{th(j-c)} = 568.2^{\circ}C/W$	$Pd(max) = --W$
	$Pd = 0.0052W$	$dT_c = 31.2^{\circ}C$	$T_c = 81.2^{\circ}C$
	$T_j = 84.2^{\circ}C$		
	D.F. = 67.4%		

SWT40 - *

TEMPERATURE RISE

Ta : 50°C

Symbol	Parts name	dT Temperature Rise (°C)				
		Mounting A	Mounting B	Mounting C	Mounting D	Mounting E
A1	TOP SWITCH	58.2	43.4	48.0	42.1	40.3
A2	3T - REGULATOR	50.4	53.1	40.0	57.0	48.3
D4	DIODE	44.4	38.1	34.5	36.5	34.8
D6	S.B.D	55.2	41.2	40.3	44.0	44.5
T1	TRANS. PULSE	49.8	35.1	40.0	38.8	38.8
C6	E.CAP	19.2	15.0	24.9	14.1	18.9
C15	E.CAP	36.7	25.1	21.5	27.4	27.7

Conditions

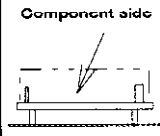
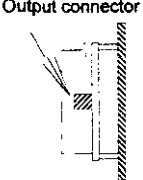
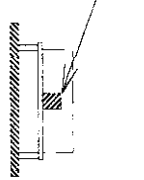
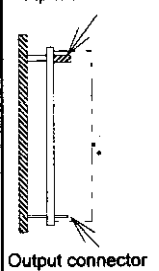
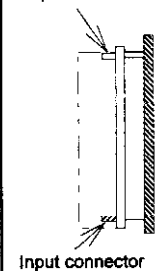
Mounting Method (Standard Mounting : A)	(A)	(B)	(C)	(D)	(E)
					
Input Voltage	100VAC	100VAC	100VAC	100VAC	100VAC
Output Voltage	Rated	Rated	Rated	Rated	Rated
Output Current	100%	75%	75%	75%	75%

SWT40 - *

TEMPERATURE RISE

Ta : 50°C

Symbol	Parts name	dT Temperature Rise (°C)				
		Mounting A	Mounting B	Mounting C	Mounting D	Mounting E
A1	TOP SWITCH	52.5	48.2	53.2	47.5	46.7
A2	3T - REGULATOR	52.1	52.1	42.9	50.2	40.4
D4	DIODE	42.9	38.2	34.4	35.6	35.3
D6	S.B.D	50.1	40.1	38.7	41.9	43.0
T1	TRANS. PULSE	46.4	36.0	40.6	37.7	40.9
C6	E.CAP	13.3	11.0	20.8	9.5	14.3
C15	E.CAP	31.3	24.0	20.6	25.4	27.3

Conditions

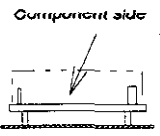
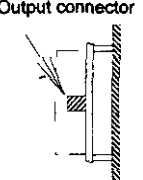
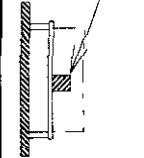
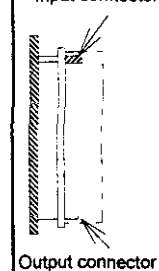
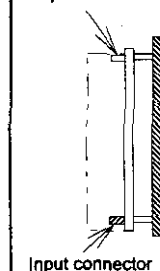
Mounting Method (Standard Mounting : A)	(A)	(B)	(C)	(D)	(E)
					
Input Voltage	200VAC	200VAC	200VAC	200VAC	200VAC
Output Voltage	Rated	Rated	Rated	Rated	Rated
Output Current	100%	75%	75%	75%	75%

SWT40 - *

E-CAP LIFETIME versus LOAD

Vin = 100VAC

Mounting Position : A

8 hours per day, 365 days operation

GRAPH OF ELECTROLYTIC CAPACITOR LIFETIME VERSUS LOAD

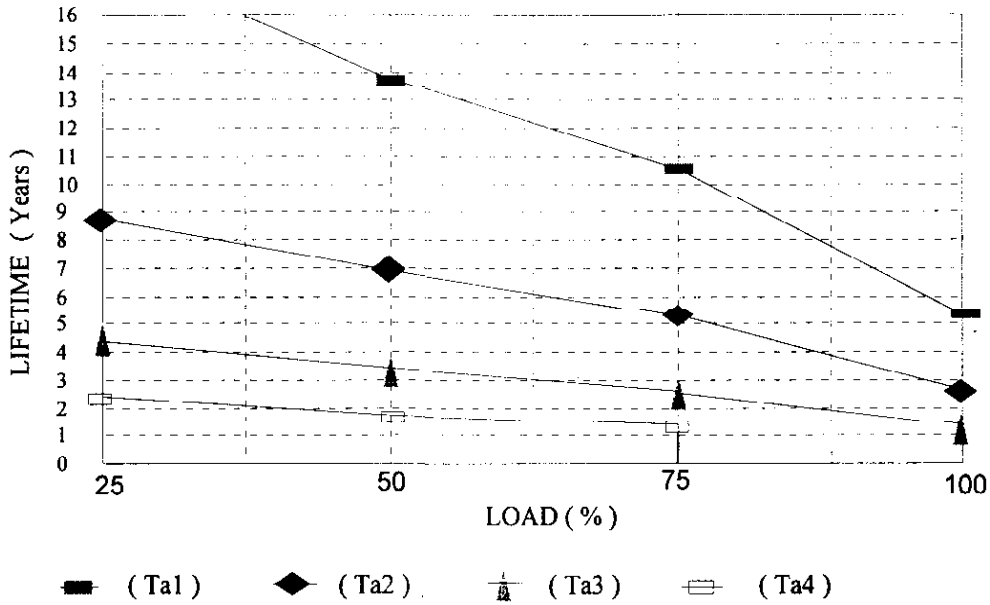

Load (%)	LIFETIME (Yrs.)			
	Ta1 = 30°C	Ta2 = 40°C	Ta3 = 50°C	Ta4 = 60°C
100	5.32	2.66	1.33	-
75	10.58	5.29	2.65	1.33
50	13.96	6.98	3.49	1.75
25	17.56	8.78	4.39	2.20

Formula :

1. For 105°C Elec. capacitor

$$L = L_o * 2^{(105-dT-Ta)/10} / (8 * 365) \text{ (Yrs.)}$$

2. For 85°C Elec. capacitor

$$L = L_o * 2^{(85-dT-Ta)/10} / (8 * 365) \text{ (Yrs.)}$$

Where :

L — Elec. capacitor computed life
(8 hours per day , 365 days operation)

L_o—Guarantee life for Elec. capacitor

T_a—Ambient temperature

dT—Temperature rise of Elec. capacitor

SWT40 - *

E - CAP LIFETIME versus LOAD

Vin = 200VAC

Mounting Position : A

8 hours per day, 365 days operation

GRAPH OF ELECTROLYTIC CAPACITOR LIFETIME VERSUS LOAD

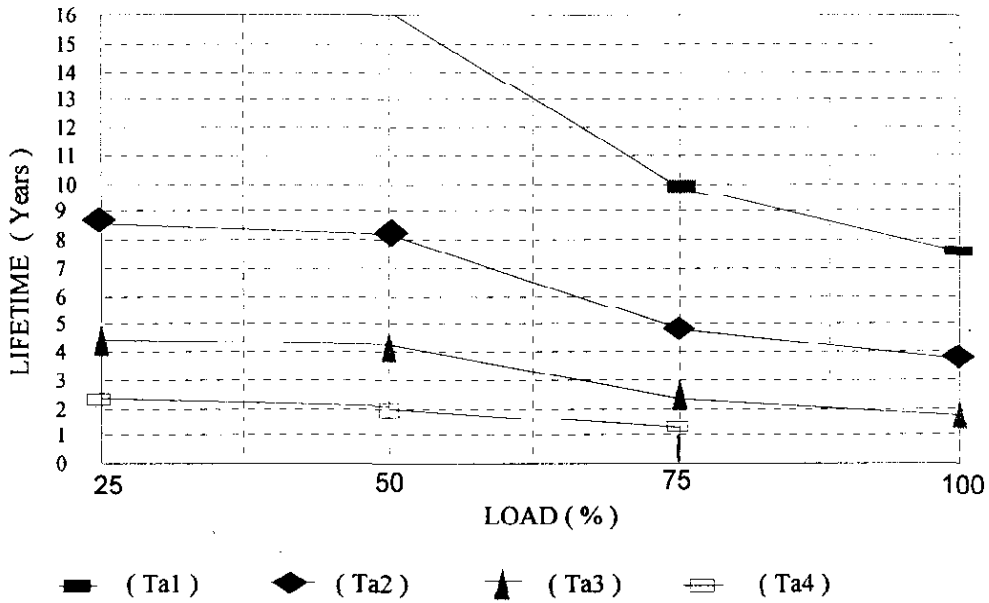

Load (%)	LIFETIME (Yrs.)			
	Ta1 = 30°C	Ta2 = 40°C	Ta3 = 50°C	Ta4 = 60°C
100	7.58	3.79	1.9	-
75	9.94	4.97	2.49	1.25
50	16.38	8.19	4.10	2.05
25	17.32	8.66	4.33	2.17

Formula :

1. For 105°C Elec. capacitor

$$L = L_o * 2^{(105-dT-Ta)/10} / (8 * 365) \text{ (Yrs.)}$$

2. For 85°C Elec. capacitor

$$L = L_o * 2^{(85-dT-Ta)/10} / (8 * 365) \text{ (Yrs)}$$

Where :

- L ---Elec. capacitor computed life
(8 hours per day , 365 days operation)
- L_o---Guarantee life for Elec. capacitor
- T_a---Ambient temperature
- dT---Temperature rise of Elec. capacitor

SWT40 - *

E - CAP LIFETIME versus LOAD

$V_{in} = 100VAC$

Mounting Position : **B**

8 hours per day, 365 days operation

GRAPH OF ELECTROLYTIC CAPACITOR LIFETIME VERSUS LOAD

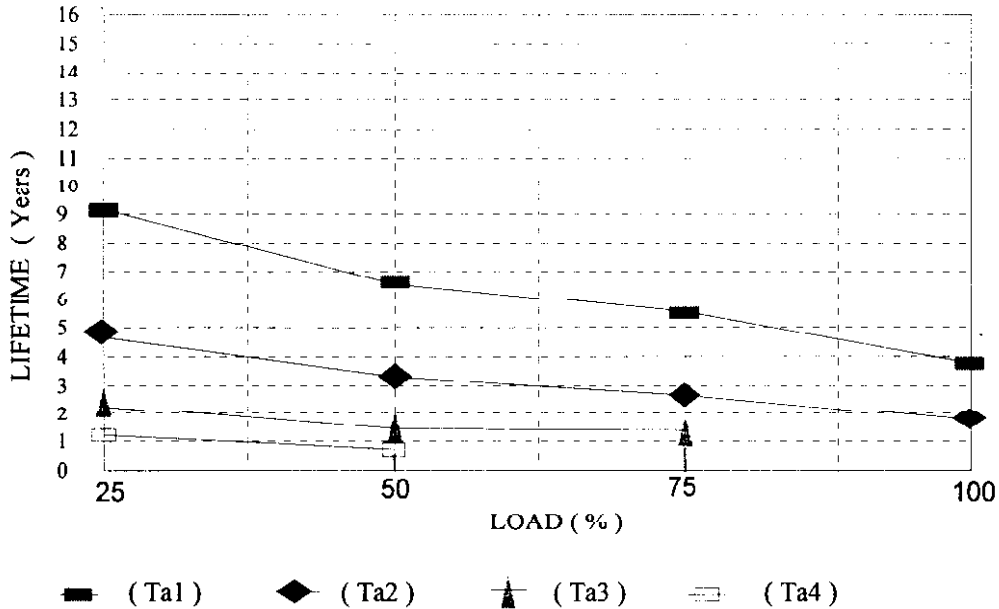

Load (%)	LIFETIME (Yrs.)			
	Ta1 = 30°C	Ta2 = 40°C	Ta3 = 50°C	Ta4 = 60°C
100	3.96	1.98	-	-
75	5.60	2.80	1.40	-
50	6.60	3.30	1.65	0.83
25	9.14	4.57	2.29	1.15

Formula :

1. For 105°C Elec. capacitor

$$L = L_0 * 2^{(105-dT-Ta)/10} / (8 * 365) \text{ (Yrs.)}$$

2. For 85°C Elec. capacitor

$$L = L_0 * 2^{(85-dT-Ta)/10} / (8 * 365) \text{ (Yrs)}$$

Where :

- L — Elec. capacitor computed life
(8 hours per day , 365 days operation)
- L₀ — Guarantee life for Elec. capacitor
- T_a — Ambient temperature
- dT — Temperature rise of Elec. capacitor

SWT40 - *

E - CAP LIFETIME versus LOAD

Vin = 200VAC

Mounting Position : **B**

8 hours per day, 365 days operation

GRAPH OF ELECTROLYTIC CAPACITOR LIFETIME VERSUS LOAD

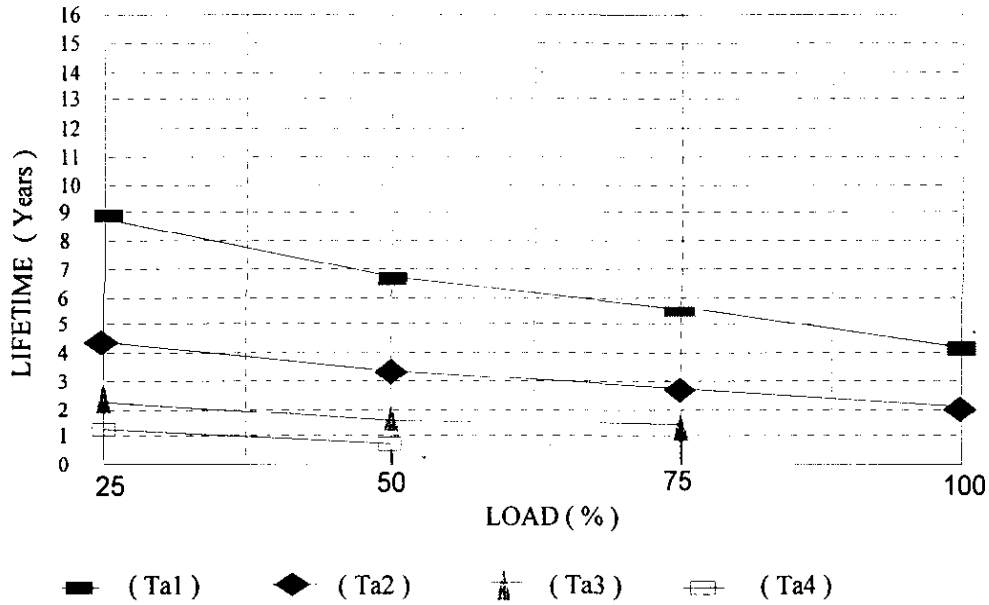

Load (%)	LIFETIME (Yrs.)			
	Ta1 = 30°C	Ta2 = 40°C	Ta3 = 50°C	Ta4 = 60°C
100	4.18	2.09	-	-
75	5.56	2.78	1.39	-
50	6.88	3.44	1.72	0.86
25	8.78	4.39	2.20	1.10

Formula :

1. For 105°C Elec. capacitor

$$L = L_o * 2^{(105-dT-Ta)/10} / (8 * 365) \text{ (Yrs.)}$$

2. For 85°C Elec. capacitor

$$L = L_o * 2^{(85-dT-Ta)/10} / (8 * 365) \text{ (Yrs)}$$

Where :

- L — Elec. capacitor computed life
(8 hours per day , 365 days operation)
- L_o — Guarantee life for Elec. capacitor
- T_a — Ambient temperature
- dT — Temperature rise of Elec. capacitor

SWT40 - *

E - CAP LIFETIME versus LOAD

V_{in} - 100VAC

Mounting Position : C

8 hours per day, 365 days operation

GRAPH OF ELECTROLYTIC CAPACITOR LIFETIME VERSUS LOAD

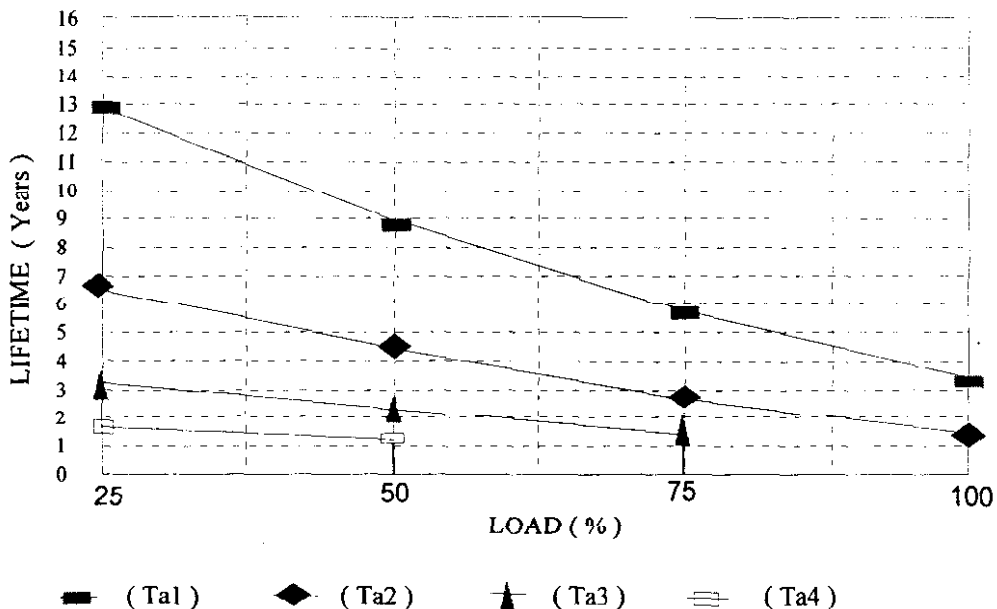

Load (%)	LIFETIME (Yrs.)			
	Ta1 = 30°C	Ta2 = 40°C	Ta3 = 50°C	Ta4 = 60°C
100	3.28	1.64	-	-
75	5.52	2.76	1.38	-
50	8.96	4.48	2.24	1.12
25	12.86	6.43	3.22	1.61

Formula :

1. For 105°C Elec. capacitor

$$L = L_0 * 2^{(105-dT-Ta)/10} / (8 * 365) \text{ (Yrs.)}$$

2. For 85°C Elec. capacitor

$$L = L_0 * 2^{(85-dT-Ta)/10} / (8 * 365) \text{ (Yrs)}$$

Where :

- L — Elec. capacitor computed life
(8 hours per day , 365 days operation)
- L₀ — Guarantee life for Elec. capacitor
- T_a — Ambient temperature
- dT — Temperature rise of Elec. capacitor

SWT40 - *

E - CAP LIFETIME versus LOAD

V_{in} = 200VAC

Mounting Position : C

8 hours per day, 365 days operation

GRAPH OF ELECTROLYTIC CAPACITOR LIFETIME VERSUS LOAD

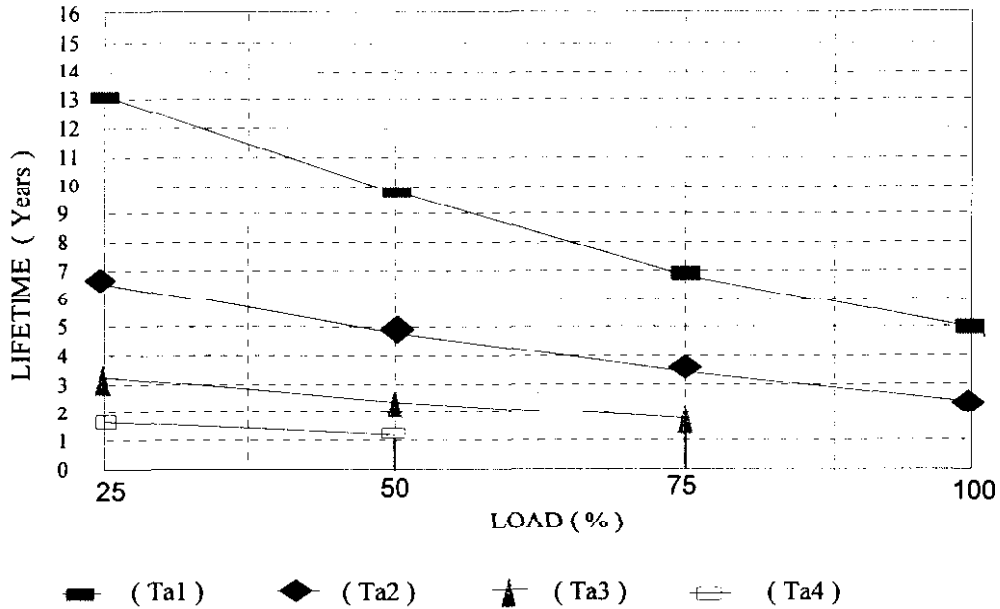

Load (%)	LIFETIME (Yrs.)			
	Ta1 = 30°C	Ta2 = 40°C	Ta3 = 50°C	Ta4 = 60°C
100	4.90	2.45	-	-
75	6.72	3.66	1.83	-
50	9.80	4.90	2.45	1.23
25	13.12	6.56	3.28	1.64

Formula :

1. For 105°C Elec. capacitor

$$L = L_0 * 2^{(105-dT-Ta)/10} / (8 * 365) \text{ (Yrs.)}$$

2. For 85°C Elec. capacitor

$$L = L_0 * 2^{(85-dT-Ta)/10} / (8 * 365) \text{ (Yrs)}$$

Where :

- L — Elec. capacitor computed life (8 hours per day , 365 days operation)
- L₀ — Guarantee life for Elec. capacitor
- T_a — Ambient temperature
- dT — Temperature rise of Elec. capacitor

SWT40 - *

E - CAP LIFETIME versus LOAD

$V_{in} = 100VAC$

Mounting Position : **D**

8 hours per day, 365 days operation

GRAPH OF ELECTROLYTIC CAPACITOR LIFETIME VERSUS LOAD

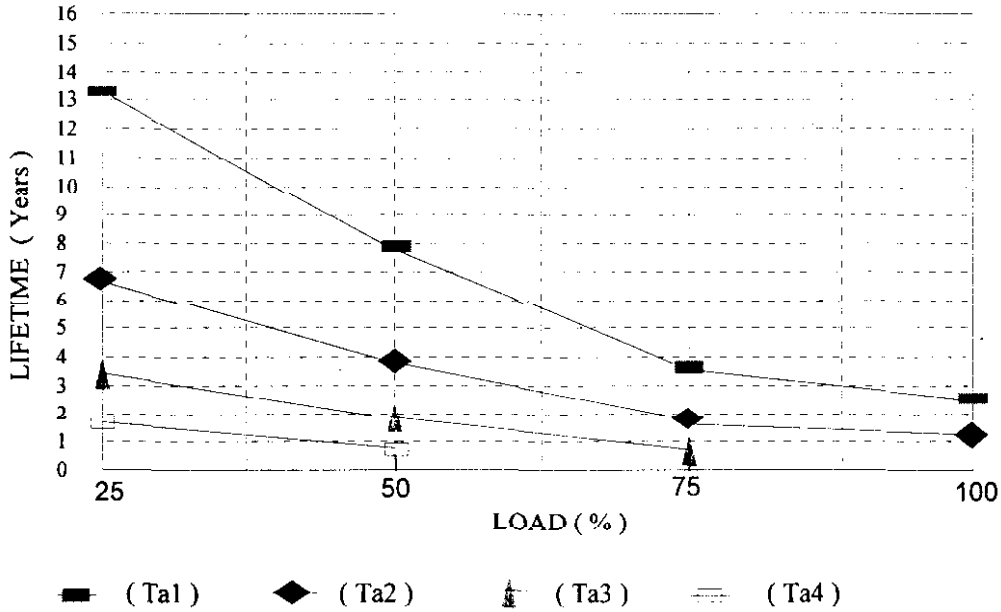

Load (%)	LIFETIME (Yrs.)			
	Ta1 = 30°C	Ta2 = 40°C	Ta3 = 50°C	Ta4 = 60°C
100	2.32	1.16	-	-
75	3.52	1.76	0.88	-
50	7.70	3.85	1.93	0.97
25	13.22	6.61	3.31	1.66

Formula :

1. For 105°C Elec. capacitor

$$L = L_o * 2^{(105-dT-Ta)/10} / (8 * 365) \text{ (Yrs.)}$$

2. For 85°C Elec. capacitor

$$L = L_o * 2^{(85-dT-Ta)/10} / (8 * 365) \text{ (Yrs)}$$

Where :

- L — Elec. capacitor computed life
(8 hours per day , 365 days operation)
- L_o — Guarantee life for Elec. capacitor
- T_a — Ambient temperature
- dT — Temperature rise of Elec. capacitor

SWT40 - *

E - CAP LIFETIME versus LOAD

Vin = 200VAC

Mounting Position : **D**

8 hours per day, 365 days operation

GRAPH OF ELECTROLYTIC CAPACITOR LIFETIME VERSUS LOAD

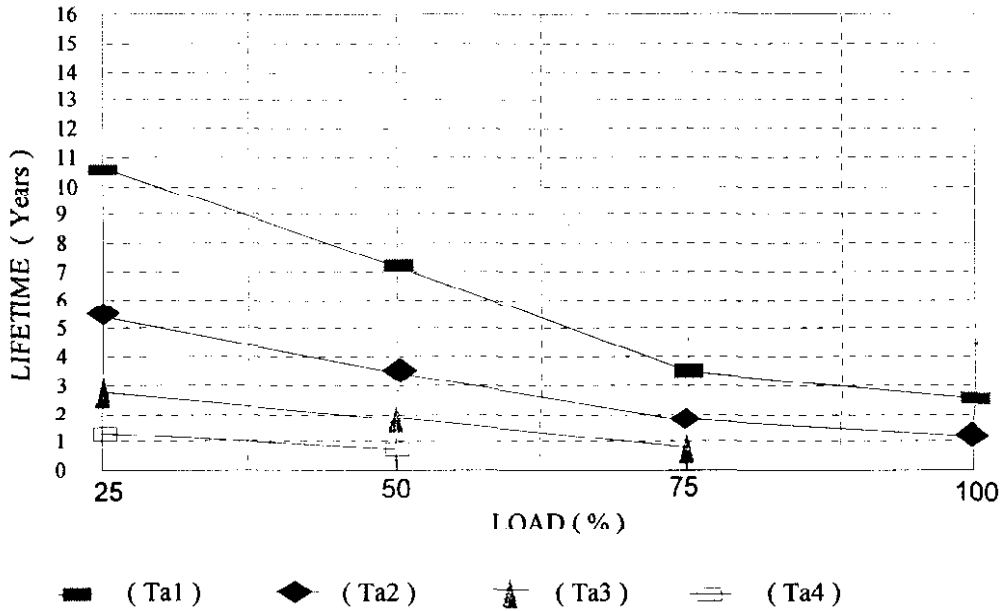

Load (%)	LIFETIME (Yrs.)			
	Ta1 = 30°C	Ta2 = 40°C	Ta3 = 50°C	Ta4 = 60°C
100	2.58	1.29	-	-
75	3.64	1.82	0.91	-
50	7.08	3.54	1.77	0.89
25	10.52	5.26	2.63	1.32

Formula :

1. For 105°C Elec. capacitor

$$L = L_o * 2^{(105-dT-Ta)/10} / (8 * 365) \text{ (Yrs.)}$$

2. For 85°C Elec. capacitor

$$L = L_o * 2^{(85-dT-Ta)/10} / (8 * 365) \text{ (Yrs.)}$$

Where :

- L — Elec. capacitor computed life (8 hours per day, 365 days operation)
- L_o — Guarantee life for Elec. capacitor
- T_a — Ambient temperature
- dT — Temperature rise of Elec. capacitor

SWT40 - *

E - CAP LIFETIME versus LOAD

Vin = 100VAC
8 hours per day, 365 days operation

Mounting Position : **E**

GRAPH OF ELECTROLYTIC CAPACITOR LIFETIME VERSUS LOAD

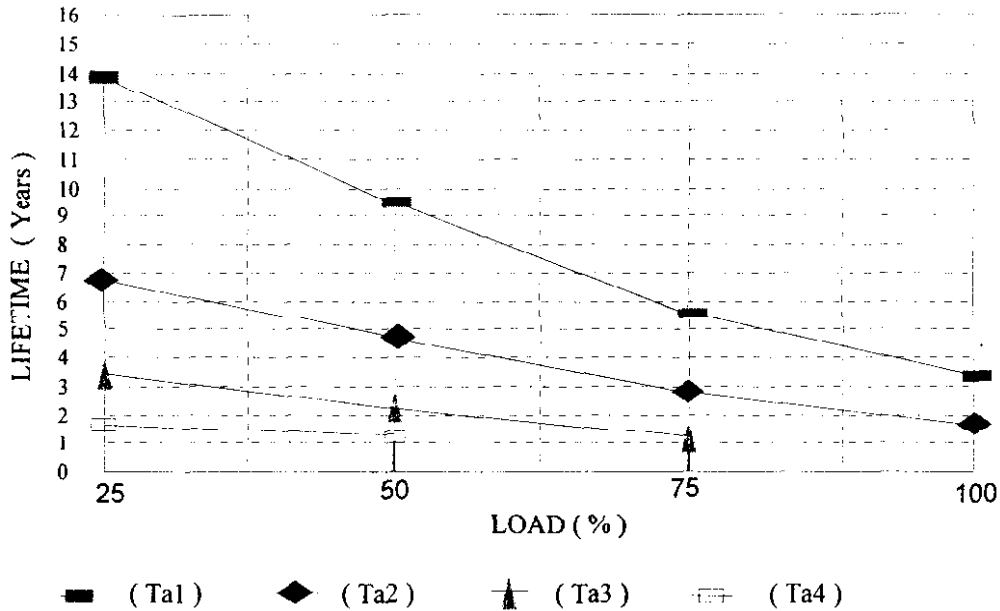

Load (%)	LIFETIME (Yrs.)			
	Ta1 = 30°C	Ta2 = 40°C	Ta3 = 50°C	Ta4 = 60°C
100	3.38	1.69	-	-
75	5.56	2.78	1.39	-
50	9.40	4.70	2.35	1.18
25	13.96	6.98	3.49	1.75

Formula :

1. For 105°C Elec. capacitor

$$L = L_o * 2^{(105-dT-Ta)/10} / (8 * 365) \text{ (Yrs.)}$$

2. For 85°C Elec. capacitor

$$L = L_o * 2^{(85-dT-Ta)/10} / (8 * 365) \text{ (Yrs)}$$

Where :

- L — Elec. capacitor computed life (8 hours per day , 365 days operation)
- L_o — Guarantee life for Elec. capacitor
- T_a — Ambient temperature
- dT — Temperature rise of Elec. capacitor

SWT40 - *

E - CAP LIFETIME versus LOAD

Vin = 200VAC

Mounting Position : E

8 hours per day, 365 days operation

GRAPH OF ELECTROLYTIC CAPACITOR LIFETIME VERSUS LOAD

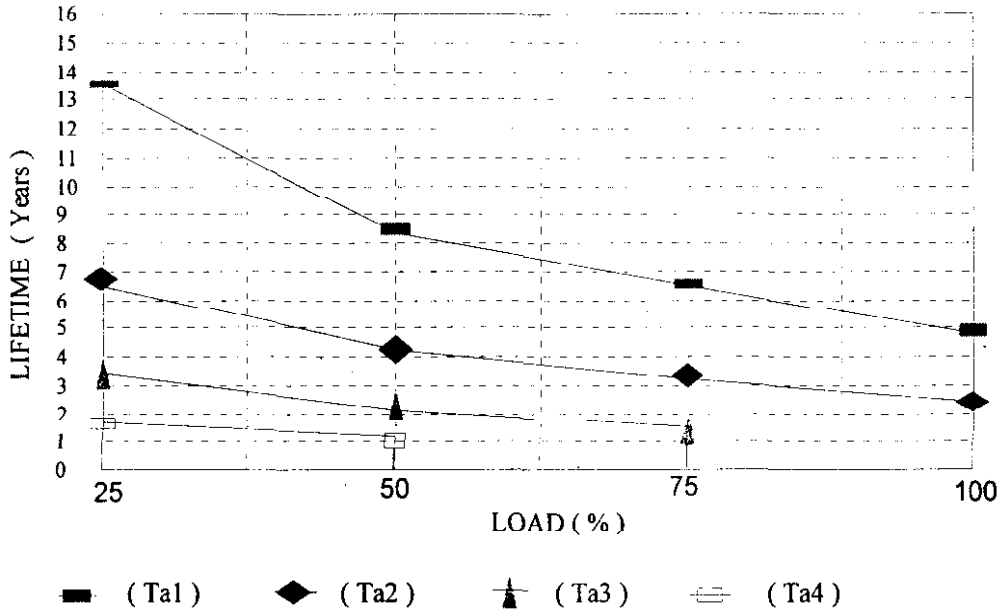

Load (%)	LIFETIME (Yrs.)			
	Ta1 = 30°C	Ta2 = 40°C	Ta3 = 50°C	Ta4 = 60°C
100	4.98	2.49	-	-
75	6.70	3.35	1.68	-
50	8.42	4.21	2.11	1.06
25	13.58	6.79	3.40	1.70

Formula :

1. For 105°C Elec. capacitor

$$L = L_o * 2^{(105-dT-Ta)/10} / (8 * 365) \text{ (Yrs.)}$$

2. For 85°C Elec. capacitor

$$L = L_o * 2^{(85-dT-Ta)/10} / (8 * 365) \text{ (Yrs)}$$

Where :

- L — Elec. capacitor computed life
(8 hours per day , 365 days operation)
- L_o — Guarantee life for Elec. capacitor
- T_a — Ambient temperature
- dT — Temperature rise of Elec. capacitor

SWT40 - *

VIBRATION TEST

Type of vibration test : A) Oscillator frequency sweep

Equipment used : Vibration test system F-400-BM-E47 (EMIC CORP.)
Vibration generator 905-FN (EMIC CORP.)

Proceduce :

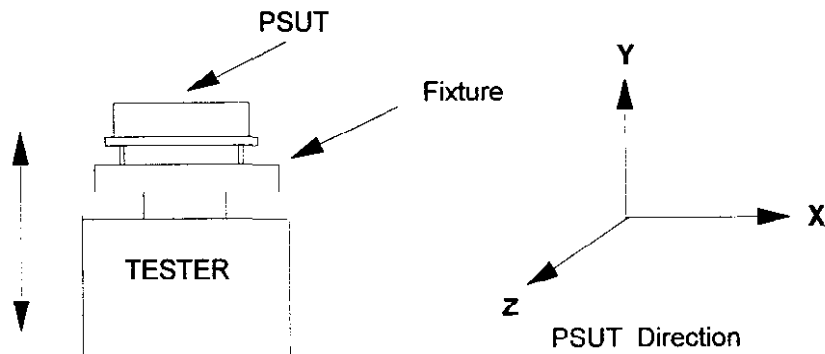

A) Vibration test with frequency sweep

Sweep frequency	:	10 - 55Hz
Sweep time	:	1min
Acceleration	:	Fixed 2G
Direction	:	X,Y,Z.
Duration	:	1hour for each direction.

Test point :

- 1) Output voltage (Apply some shock when checking the output voltage, and observe any abnormalities.)
- 2) Ripple voltage (At nominal input and output.)
- 3) Mechanical condition (No breakage.)

SWT40 - *

Test result :

Test Point	Output voltage (V)			Ripple voltage (mV)			Mechanical Condition	Note	
	CH1	CH2	CH3	CH1	CH2	CH3			
Before test	4.999	12.216	-5.080	80	70	70	O.K		
After test	Direction								
	X	5.003	12.237	-5.078	80	70	70	O.K	
	Y	5.003	12.237	-5.078	80	70	70	O.K.	
Z	5.003	12.237	-5.078	80	70	70	O.K.		

Evaluation result

:

PASS / FAIL

Visual inspection result

:

PASS / FAIL

SWT40 - *

NOISE SIMULATION TEST

Circuit for measurement and equipment used :

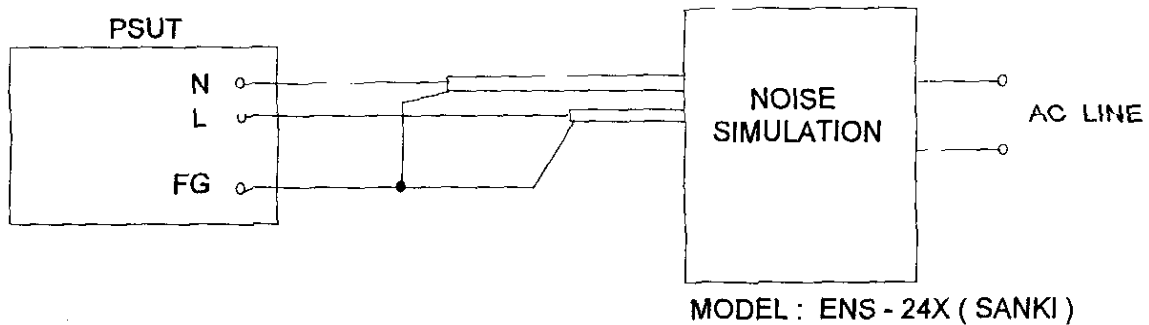

Test condition :

Input voltage	: 100VAC
Output voltage	: Rated
Output current	: Min , 100%
Ambient temp.	: 25°C

Settings :

MODE	: Normal , Common
TRIG SELECT	: Line
PULSE WIDTH	: 50 , 200 , 800 , 1000ns
PHASE SHIFT	: 0° ~ 360°
POLARITY	: + , -
NOISE LEVEL	: 0 ~ 2KV

Acceptance criteria :

- 1) No damage of PSUT.
- 2) No output failure.
- 3) Check any abnormalities. (e.g. noise)

Evaluation result :

PASS / FAIL

ELECTROSTATIC DISCHARGE TEST

Equipment used : SET - 30E (SANKI ELECTRONIC)
 Discharge resistor : 250 Ω
 Capacitor unit : 200 pF

Test conditions : Input voltage : Nominal Line (100VAC)
 Output voltage : Rated
 Output current : 100%
 Ambient temperature : 25°C
 Applied voltage : +3KV, +5KV, +10KV, +15KV

Procedure : *The PSUT should be in a good working condition.*
 Discharge the applied voltage to the touchable parts of the PSUT (Chassis, Input Terminals, Output Terminals, FG Terminal) and check any abnormalities.

Each point to be tested 3 times with different polarity.
 Voltage should be applied from 3KV to 15KV.

Test circuit :

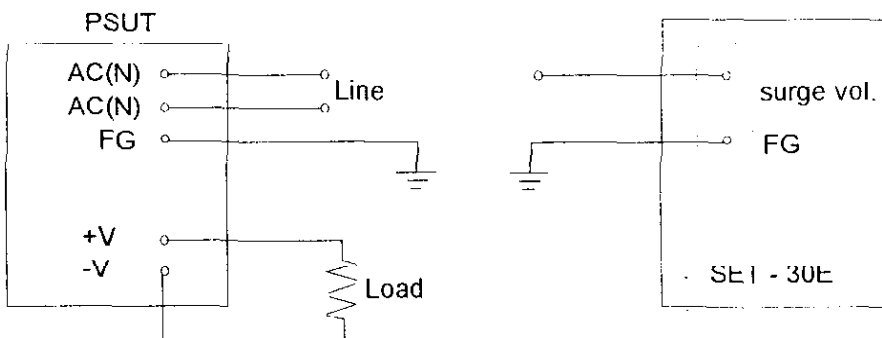

Acceptance criteria : 1) No damage of PSUT.
 2) No output failure.
 3) No abnormalities.

Evaluation result : (PASS) / FAIL

LIGHTNING SURGE TEST

Test circuit, Test equipment

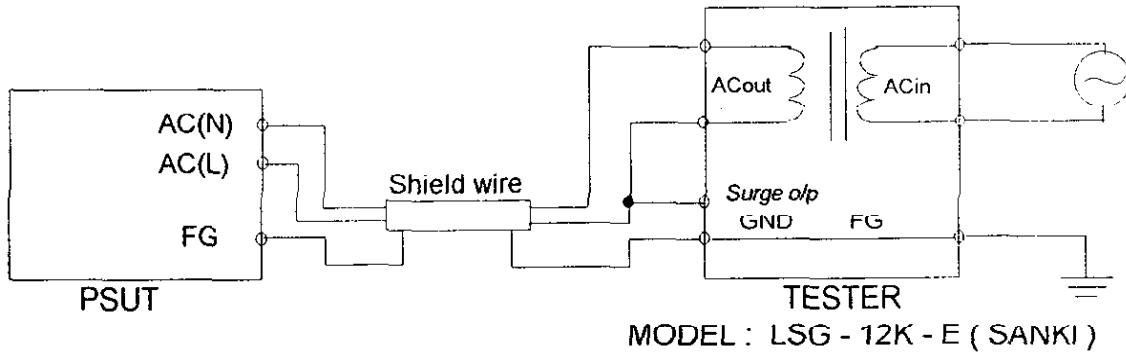

- Test conditions :
- | | | |
|-----------------|---|----------------------------------|
| Input voltage | : | 100VAC |
| Output voltage | : | Rated |
| Output current | : | Rated |
| Ambient temp. | : | 25°C |
| Applied voltage | : | From 3KV in steps of 0.5KV |
| | | Check the max. withstand voltage |
| Applied point | : | Between FG - AC |
| Number of test | : | Each voltage 3 times |
| Polarity | : | + , - |

Applied voltage waveform :

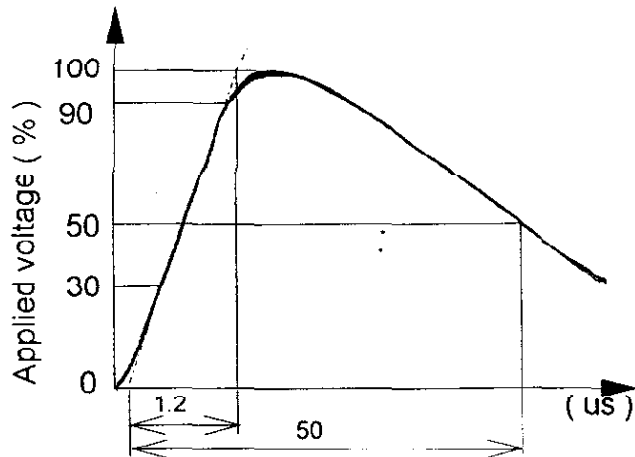

- Acceptance criteria
- 1) No damage of PSUT.
 - 2) No output failure.
 - 3) No abnormalities.

Evaluation result : 5.0KV **PASS** / FAIL