

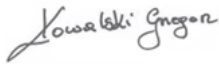

Test Report issued under the responsibility of:

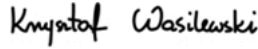

IEC 60601-1	
Medical electrical equipment	
Part 1: General requirements for basic safety and essential performance	
Report Number	E349607-D1109-1/A0/C0-CB
Date of issue	2023-12-07
Total number of pages	174
Name of Testing Laboratory preparing the Report	UL International Polska sp. z o.o. Równoległa 4 02-235 Warsaw Poland
Applicant's name	TDK-LAMBDA UK LTD
Address	KINGSLEY AVENUE ILFRACOMBE DEVON EX34 8ES UNITED KINGDOM
Test specification:	
Standard	IEC 60601-1:2005, IEC 60601-1:2005/AMD1:2012, IEC 60601-1:2005/AMD2:2020
Test procedure	CB Scheme
Non-standard test method	N/A
TRF template used	IECEE OD-2020-F1:2020, Ed.1.3
Test Report Form No	IEC60601_1U
Test Report Form(s) Originator	UL(US)
Master TRF	2022-05-13
Copyright © 2022 IEC System of Conformity Assessment Schemes for Electrotechnical Equipment and Components (IECEE System). All rights reserved.	
This publication may be reproduced in whole or in part for non-commercial purposes as long as the IECEE is acknowledged as copyright owner and source of the material. IECEE takes no responsibility for and will not assume liability for damages resulting from the reader's interpretation of the reproduced material due to its placement and context.	
If this Test Report Form is used by non-IECEE members, the IECEE/IEC logo and the reference to the CB Scheme procedure shall be removed.	
This report is not valid as a CB Test Report unless signed by an approved IECEE Testing Laboratory and appended to a CB Test Certificate issued by an NCB in accordance with IECEE 02.	
General disclaimer:	
The test results presented in this report relate only to the object tested. This report shall not be reproduced, except in full, without the written approval of the Issuing NCB. The authenticity of this Test Report and its contents can be verified by contacting the NCB, responsible for this Test Report.	

Test item description:	Switch mode power supply	
Trade Mark(s)	Trademark image(s): 	
Manufacturer	Same as Applicant	
Model/Type reference:	NV175 Series NV-175 Series, NV1-1G000 (See Model Differences for details)	
Ratings:	NV175 Series; NV-175 Series: 100-240Vac (Nominal), 90-264V (Full Tolerance), 45-63Hz, 3Arms NV1-1G000 only: 88.9-240Vac (Nominal), 80-264V (Full Tolerance), 45-63Hz, 3Arms (See Model Differences for details)	
Responsible Testing Laboratory (as applicable), testing procedure and testing location(s):		
<input checked="" type="checkbox"/>	CB Testing Laboratory:	
Testing location/ address	UL International Polska sp. z o.o. Równoległa 4 02-235 Warsaw Poland	
Tested by (name, function, signature)	Grzegorz Kowalski, Handler	
Approved by (name, function, signature) ..	Krzysztof Wasilewski, Reviewer	
<input type="checkbox"/>	Testing procedure: CTF Stage 1:	
Testing location/ address		
Tested by (name, function, signature)		
Approved by (name, function, signature) ..		
<input type="checkbox"/>	Testing procedure: CTF Stage 2:	
Testing location/ address		
Tested by (name, function, signature)		
Witnessed by (name, function, signature) ..		
Approved by (name, function, signature) ..		
<input checked="" type="checkbox"/>	Testing procedure: CTF Stage 3:	
<input type="checkbox"/>	Testing procedure: CTF Stage 4:	

Testing location/ address :	TDK-Lambda UK Ltd, Kingsley Avenue, Ilfracombe, North Devon, EX34 8ES, United Kingdom	
Tested by (name, function, signature) :	M.Carter, N.Marsh, Tester	See the original CBTR for signature
Witnessed by (name, function, signature) . :	Dennis Butcher, Witness	See the original CBTR for signature
Approved by (name, function, signature) .. :	Krzysztof Wasilewski, Project Reviewer	See the original CBTR for signature
Supervised by (name, function, signature) :	Ricky Wang, Project Handler	See the original CBTR for signature

List of Attachments (including a total number of pages in each attachment):

Refer to Appendix A of this report. All attachments are included within this report.

Summary of testing:**Tests performed (name of test and test clause):**

Refer to the Test List in Appendix B of this report if testing was performed as part of this evaluation.

Testing location:

Refer to the Test List in Appendix B of this report if testing was performed as part of this evaluation.

Summary of compliance with National Differences (List of countries addressed):

List of countries addressed: United States of America, Canada, Japan

[X] The product fulfils the requirements of National standard AAMI ES60601-1:2005,ES60601-1:2005/AMD1 1:2012 , ES60601-1:2005/AMD2:2021, Canadian National standard: CAN/CSA-C22.2 No. 60601-1:08, CAN/CSA-C22.2 No. 60601-1:14 (including amendment 1) and Amendment 2:2022 (MOD) to CAN/CSA-C22.2 No. 60601-1:14, National standard JIS T 0601-1:2023.

Statement concerning the uncertainty of the measurement systems used for the tests

(may be required by the product standard or client)

[] **Internal procedure used for type testing through which traceability of the measuring uncertainty has been established:**

Procedure number, issue date and title:

Calculations leading to the reported values are on file with the NCB and testing laboratory that conducted the testing.

[X] **Statement not required by the standard used for type testing**

(Note: When IEC or ISO standard requires a statement concerning the uncertainty of the measurement systems used for tests, this should be reported above. The informative text in parenthesis should be delete in both cases after selecting the applicable option)

Copy of marking plate

The artwork below may be only a draft. The use of certification marks on a product must be authorized by the respective NCBs that own these marks.

Refer to the enclosure(s) titled Marking Label in the Enclosures section in Appendix A of this report for a copy.

Test item particulars :	
Classification of Installation and Use:	For building into host equipment
Supply Connection:	For building into host equipment
Device type (component/sub-assembly/ equipment/ system):	Component Switch Mode Power Supply
Intended use (Including type of patient, application location):	For building into host equipment
Mode of Operation:	Continuous
Accessories and detachable parts included:	None
Other Options Include:	None
Possible test case verdicts:	
- test case does not apply to the test object	N/A
- test object does meet the requirement	P (Pass)
- test object was not evaluated for the requirement.....	N/E (collateral standards only)
- test object does not meet the requirement	F (Fail)
Abbreviations used in the report:	
- normal condition	N.C.
- single fault condition.....	S.F.C.
- means of Operator protection	MOOP
- means of Patient protection	MOPP
Testing :	
Date of receipt of test item	2018/08/07 to 2018/10/29
Date(s) of performance of tests	2018/09/17 to 2018/10/29
General remarks:	
"(See Enclosure #)" refers to additional information appended to the report. "(See appended table)" refers to a table appended to the report.	
Throughout this report a <input type="checkbox"/> comma / <input checked="" type="checkbox"/> point is used as the decimal separator.	
Manufacturer's Declaration per sub-clause 4.2.5 of IEC60060-2:	
The application for obtaining a CB Test Certificate includes more than one factory location and a declaration from the Manufacturer stating that the sample(s) submitted for evaluation is (are) representative of the products from each factory has been provided	Yes
When differences exist; they shall be identified in the General product information section.	
Name and address of factory (ies)..... :	TDK-LAMBDA UK LTD KINGSLEY AVE ILFRACOMBE DEVON EX34 8ES UNITED KINGDOM PANYU TRIO MICROTRONIC CO. LTD. SHIJI INDUSTRIAL ESTATE DONGYONG, NANSHA CHINA Trio-Tronics (Thailand) Ltd 7/295 Mu.6, Map Yang Phon Sub-District Pluak Daeng District, Rayong Province Thailand

General product information and other remarks:**Report Summary**

All applicable tests according to the referenced standard(s) have been carried out.

Please refer to report modification summary table in GPI section for more details.

Refer to the Report Modifications for any modifications made to this report.

Product Description

Component Switch mode power supply NV175 or NV-175 series.

Model Differences

NV175 or NV-175 models as described below:

Units may be marked with a Product Code: K1x or Q1x where x may be any number of letters and/or numbers 0 to 9.

Unit Configuration (Description :) Code may be prefixed by NS # followed by / or - (where # may be any number of characters indicating non- safety related model differences).

Unit Configuration Code:

NVx-abcde-f-g-h-ijk

where:

x = 1 for 175

a = Number of Outputs : 1, 2, 3 or 4

b = Channel 1 Output Voltage†: 5, T, F, E or G

c = Channel 2 Output Voltage†: 1, 2, 3, 5, 5L, 7, F or 0

d = Channel 3 Output Voltage†: 3L, 5L, 7, TL, FL, T, F, G followed by Y for negative output or 0

e = Channel 4 Output Voltage†: 3H, 5H, 7, T, F, TH, FH, 0H (fan only channel 4 output) followed by V for variable output followed by P for positive output or 0

f = Global Option : N for 5V version, N1 for 12V version, N2 for 13.5V version, N3 for 5V version with ATX compatibility, N4 for 12V version with ATX compatibility, N5 for 13.5V version with ATX, N6 for 12-13.5V version, N7 for 12-13.5V version with ATX or nothing for no Global Option present

g = U for U chassis, C for U chassis and cover, F for U chassis and cover with fan, I for U chassis and cover with fan and IEC inlet or nothing for Open Frame

h = Blank is the standard upright output connector, R is for the right angle output connector, H is for high altitude, HR is for high altitude with right angle output connector, M is for IEC60601-1, MR is for IEC60601-

1 spacings with right angle connector

ijk = Three numbers from 0 to 9 which denotes various output voltages and currents within the specified ranges of each output for a particular unit or blank for standard output settings

† Table1: Output Voltage Cross Reference

Designation	Output Voltage
0	Omit output
A	1.5
1	1.8
B	2
2	2.7
3	3.3
5	5
7	7
T	12
F	15
E	18

G 24

Output channels and Global Options ratings are in accordance with the following table subject to variations and limitations of use below:

Output Channel Designation Vout Adj. Range Output Current

CH1 5 5 5 - 5.5 25A
 T 12 12 - 15.5 15A
 F 15 12 - 15.5 15A
 E 18 16 - 20 10A
 G 24 24 - 28.5 7.5A
 CH2 1 1.8 0.9 - 3.8 15A
 2 2.7 2.5 - 3.8 15A
 3 3.3 2.5 - 3.8 15A
 CH2 (CH1 12V) 5 5 3.3 - 5.5 10A
 CH2 (CH1 15V) 5 5 3.3 - 5.5 10A
 CH2 (CH1 24V) 5L 5 Fixed 2A
 5 5 3.3 - 5.5 8A
 7 7 5.5 - 8 5.5A
 F 15 12-15.5 6A
 CH3 7 +/-7 7 - 8 5A
 T +/-12 12 - 15 5A
 F +/-15 12 - 15 5A
 G +/-24 18 - 24.5 2.5A
 3L +/-3.3 Fixed 2A
 5L +/-5 Fixed 2A
 TL +/-12 Fixed 2A
 FL +/-15 Fixed 2A
 CH4 3H +/-3.3 Fixed 2A
 5H +/-5 Fixed 2A
 7 +/-7 7 - 8 1A
 T +/-12 Fixed 1A
 F +/-15 Fixed 1A
 TH +/-12 Fixed 2A
 FH +/-15 Fixed 2A
 THV +/-12 12 - 15 2A
 FHV +/-15 12 - 15 2A
 CH4 (fan output) OH - - -
 Global Option N 5 Fixed 2A
 N1 12 Fixed 1A
 N2 13.5 Fixed 1A
 N3 5(ATX) Fixed 2A
 N4 12(ATX) Fixed 1A
 N5 13.5(ATX) Fixed 1A
 N6 12 12-13.5* 1A
 N7 12(ATX) 12-13.5* 1A

Channels 1 and 2 combined output currents must not exceed 25A

*Can only be set at the factory.

Variations and limitations of use:

All NV175 or NV-175 PSUs can output 180W except 5V channel 1 models which can output 175W. These power ratings are for channels 1 to 4. The global option output can be run in addition to the channel 1 to 4 maximum power outputs.

Units with channel 1 T and G outputs (no other channels fitted) have a peak power output of 200W including the global option with the following duty cycles:

In any 5 minutes 30% at 200W followed by 70% at 171W (average 180W)
 In any 5 minutes 20% at 200W followed by 80% at 175W (average 180W)

Options -H and -HR meet spacings for 5000m.

Options -M and -MR meet IEC60601-1 Edition 2 Reinforced spacing's with the following limitations (interpolated creepage spacings):

Channel 1 cannot be 5V model (T1 and T2 with foils)
 Channel 2 cannot be fitted, except model K10142x where x may be any letter not affecting Safety.
 Cannot be global option variants

Fan versions:

Channel 1 with G output, 25V maximum with 5V channel 2 maximum output current of 7A.
 Channel 1 with G output, 25V maximum with 7V channel 2 maximum output current of 5.5A.
 Channel 1 with G output, 5L channel 2 maximum output current 1.8A.
 Channel 2 with T and F outputs, channel 2 maximum output current of 9A.
 Channel 4 maximum output current of 1.5A

Model NV1-1G000 (with or without global option or -M/-MR option) may also be run with Channel 1 output voltage range 22.5V to 28V with maximum current of 7.5A and maximum power of 180W

Model NV1-1G000 (with or without -M option) may also be run at 80Vac to 264Vac input, output: 24V to 28V at 6.25A maximum current and 150W maximum power.

Model NV1-1G000-M operation to 4000m.

The products listed in the following table are typical examples:

Model	CH1	CH2	CH3	CH4	Global Option
NV1-453FF	5V/25A	3.3V/15A	15V/5A	15V/1A	-
NV1-4G5FFH-N3	24V/7.5A	5V/8A	15V/5A	15V/2A	5V/2A
NV1-350TT-N	5V/25A	-	12V/5A	12V/1A	5V/2A
NV1-453TT-N1	5V/25A	3.3V/15A	12V/5A	12V/1A	12V/1A
NV1-250T0-N2	5V/25A	-	12V/5A	-	13.5V/1A

Custom Models:

All ratings as per standard models unless otherwise stated.

Model: NS-LAM/NV1-453TTH-N2-H-C (K10035)
 Rated to 4600m altitude
 Input voltage range from 90Vac to 264Vac

Model: NS-LAMF/NV1-4G5TTH-F (K10066)
 5L low current channel 2 fitted.
 Channel 2 rated: 5V, 1.4A

Additional Information

Cooling for units with customer supplied air (open frame, U and C options)

The following method must be used for determining the safe operation of PSUs.

The components listed in the following table must not exceed the temperatures given. To determine the component temperatures the heating tests must be conducted in accordance with the requirements of the standard in question. Consideration should also be given to the requirements of other safety standards.

Test requirements include: PSU to be fitted in its end-use equipment and operated under the most adverse conditions permitted in the end-use equipment instruction manual/specification and which will result in the highest temperatures in the PSU. To determine the most adverse conditions consideration should be given to the end use equipment maximum operating ambient, the PSU loading and input voltage, ventilation, end use equipment orientation, the position of doors & covers, etc. Temperatures should be monitored using type K fine wire thermocouples (secured with cyanoacrylate adhesive, or similar) placed on the hottest part of the component (out of any direct airflow) and the equipment should be run until all temperatures have stabilised.

Circuit Ref.	Description	Max. Temperature (°C)
L3, L7	Common mode choke winding	140
C1, C4	X capacitors	100
C6, C12	Capacitor	105
L2	Boost choke winding	130
C7	Electrolytic capacitor	70 (105)
T1, T2	Transformer winding	130
XU3	Control board optocoupler	100
TX701	Global option transformer	90
L5	Channel 1 Output choke	125
XL401	Channel 2 Output choke	125
XL601	5L channel 2 output choke	125
XU601	5L channel 2 IC	115
XL501 or XL601	Channel 3 and 4 output choke	125
IC1*	Channel 4 Voltage regulator	110
XQ406	Ch2 highside FET (SMA 2)	115
XV504	Ch3 highside FET (SMA 3)	115
XU601	Ch4 IC (SMA 4)	115
Various	All other electrolytic capacitors	90 (105)

* 1A channel 4 only

Higher temperatures limits (in brackets) may be used but product life may be reduced.

Technical Considerations

- The product was investigated to the following standards:

Main Standard(s):

IEC 60601-1:2005 + AMD1:2012 + AMD2:2020

From Country Differences:

- United States of America: AAMI ES60601-1:2005, ES60601-1:2005/AMD1 1:2012 , ES60601-1:2005/AMD2:2021
- Canada: CAN/CSA-C22.2 No. 60601-1:08, CAN/CSA-C22.2 No. 60601-1:14 (including amendment 1) and Amendment 2:2022 (MOD) to CAN/CSA-C22.2 No. 60601-1:14

Additional Standards:

National standard JIS T 0601-1:2023

- The following additional investigations were conducted: -
- The product was not investigated to the following standards or clauses: Electromagnetic Compatibility (IEC 60601-1-2)
Clause 14, Programmable Electronic Systems
Biocompatibility (ISO 10993-1)
- The following accessories were investigated for use with the product: N/A

- The degree of protection against harmful ingress of water is: Ordinary
The mode of operation is: Continuous
The product is suitable for use in the presence of a flammable anesthetics mixture with air or oxygen or with nitrous oxide: No
The IEC inlet and the fan assembly enclosure face must not be made accessible within the host equipment without further evaluation during installation.
Multilayer PWB's accepted under CBTR Ref. No.: E349607-A23 dated 2014-07-31 and letter Report, Enclosure 8-05 of this report.

Engineering Conditions of Acceptability

When installed in an end-product, consideration must be given to the following:

Insulation (Separation) between primary - secondary output circuits: 2 MOPPs for the -M and -MR models and 2 MOOPs for all other models.

Power Supply tested in 25°C, 95%RH. End product Risk Management Process to determine risk acceptability criteria.

The output circuits have not been evaluated for direct patient connection (Type B, BF or CF).

End product Risk Management Process to include consideration of requirements specific to the Power Supply.

End product to determine the acceptability of risk in conjunction to the use of Thermal Cut-off and Overcurrent releases as part of the power supply.

Insulation (Separation) between primary - earth: 1 MOOP.

The power supplies have been assessed as component parts. It is the installer's responsibility to ensure that the final installation is in accordance with the NV175, NV-175 instruction manual and that it is in compliance with IEC60601-1 & EN60601-1.

Except for permanently installed equipment, the overall equipment in which these products are installed must be fitted with double pole fusing as detailed in the special instructions section of the NV175 instruction manual.

This product range is available as a forced air-cooled version with a 3 pin input connector (Molex type) or an IEC60320 Inlet. It is also available as a customer air-cooled version where the end cap is not fitted and the customer must provide airflow and measure appropriate temperatures of components within the product. There are three versions of customer airflow, these being, Open frame, fitted with a "U" chassis, fitted with a "U" chassis and cover.

Although the standard only requires testing for a 40°C ambient temperature the equipment has been rated and therefore tested for an operation at 50°C ambient temperature.

A suitable fire and electrical enclosure must be provided by the end product.

Connection to the protective conductor terminal within the end product must be ensured.

Overcurrent protection must be provided by the end equipment to the neutral supply connection.

The end-product Electric Strength Test is to be based upon a maximum working voltage of: Primary-SELV 2 MOPPs: 278 Vrms, 542 Vpk(-M and -MR only). Primary-SELV 2 MOOPs: 337 Vrms, 616 Vpk. , Primary-Earthed Dead Metal: 306 Vrms, 418 Vpk(-M and -MR only). Primary-Earthed Dead Metal: 337 Vrms, 608 Vpk.

Report Modifications

Date Modified (Year-Month-Day)	Modifications Made (include Report Reference Number)	Modified By
2023-12-07	<p>This report is a reissue of CBTR ref No: E349607-D1009-1/A1/C0-UL dated 2022-07-07 and E349607-D13-CB-2-Amendment2 dated 2022-07-07 including CB Test Certificate Ref. No. DK-65814-A1-UL dated: 2022-07-13. Based on the previously conducted testing and the review of product technical documentation including photos, schematics, wiring diagrams and similar, has been determined that the product continues to comply with the standard. Based on the previously conducted testing it was determined that they are representative for compliance with the new edition of the standard.</p> <p>The reissue was done due to:</p> <ul style="list-style-type: none"> - upgrade of the compliance with the latest standards: AAMI ES60601-1:2005, ES60601-1:2005/AMD1:2012, ES60601-1:2005/AMD2:2021, CSA-C22.2 No. 60601-1:14, Amendment 2:2022 (MOD) to CAN/CSA-C22.2 No. 60601-1:14, IEC 60601-1:2005 + AMD1:2012 + AMD2:2020 - change of the report number - update of the license numbers for capacitors. <p>No changes to the construction and documentation of the device.</p>	Grzegorz Kowalski

Insulation Diagram - (001) InsulationDiagramAndTable

INSULATION DIAGRAM

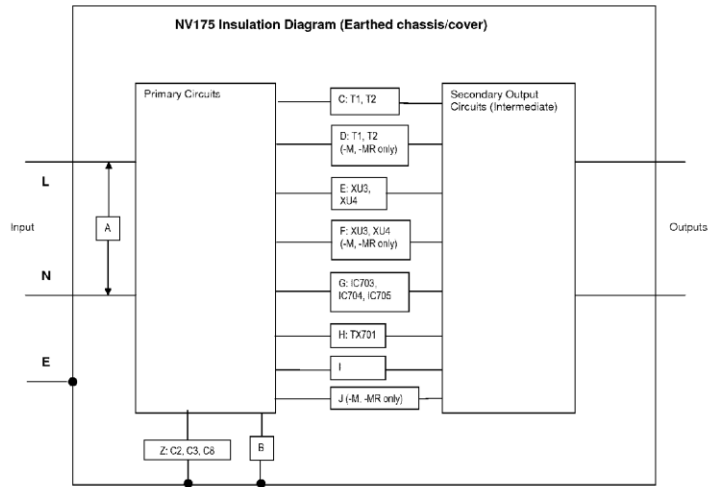

Insulation Diagram - (001) InsulationDiagramAndTable

TABLE: INSULATION DIAGRAM										Pass
Pollution degree.....:				IIIb						-
Overvoltage category.....:				II						-
Altitude.....:				3000m, 4000m for model NV1-1G000-M and 5000m for -H and -HR models						-
Additional details on parts considered as applied parts.....:				None						-
Area	Number and type of Means of Protection: MOOP, MOPP	CTI	Working voltage		Required creepage (mm)	Required clearance (MM)	Measured creepage (mm)	Measured clearance (mm)	Remarks	
			V _{rms}	V _{pk}						
A	MOOP	IIIb	240	340	2.4	2.3	4.9	4.9	J2 pin 3 live pad to J1 pin 1 neutral pad.	
A	MOOP (NV1-1G000-M)	IIIb	240	340	2.6	2.6	4.9	4.9	J2 pin 3 live pad to J1 pin 1 neutral pad.	
B	1 MOOP	IIIb	240	340	2.4	2.3	4.2	4.2	F1 flood to L6 earth pad.	
B	1 MOPP	IIIb	240	340	4.0	2.5	4.2	4.2	F1 flood to L6 earth pad. (-M and -MR)	
B	1 MOPP (NV1-1G000-M)	IIIb	240	340	4.0	2.9	4.2	4.2	F1 flood to L6 earth pad.	
B	1 MOOP	IIIb	337	608	3.5	2.7	6.5	4.7	IC702 pin 6 Y5 earth pad (-Nx* only)	
B	1 MOOP	IIIb	306	418	3.3	2.3	6.2	6.2	C7 body to Y4 earth pad	
B	1 MOPP	IIIb	306	418	4.8	3.5	6.2	6.2	C7 body to Y4 earth pad	
B	1 MOPP (NV1-1G000-M)	IIIb	306	418	4.8	4.0	6.2	6.2	C7 body to Y4 earth pad	
B	1 MOOP	IIIb	306	418	3.3	3.0	>8.0	4.5	C7 body to cover (-H and -HR models 5000m)	
B	1 MOOP	IIIb	240	368	3.0	3.0	>8.0	3.9	XD706 to chassis side (-H and -HR models 5000m)	
C	2 MOOP	IIIb	278	542	5.8	5.1	8.0	8.0	T2 primary to secondary pads	
C	2 MOOP	IIIb	278	542	6.6	6.6	7.4	7.0	T2 primary to secondary	

Insulation Diagram - (001) InsulationDiagramAndTable

									tracks (-H and -HR models 5000m)
D	2 MOPP	IIIb	278	542	8.8	7.0	9.0	9.0	T2 primary to secondary pads (-M and -MR only)
D	2 MOPP (NV1-1G000-M)	IIIb	278	542	8.8	8.0	9.0	9.0	T2 primary to secondary pads
E	2 MOOP	IIIb	240	386	4.8	4.6	>10.4	7.5	XU3, XU4 primary to secondary
F	2 MOPP	IIIb	240	386	7.9	5.0	>10.4	7.5	XU3, XU4 primary to secondary (-M and -MR only)
F	2 MOPP (NV1-1G000-M)	IIIb	240	386	7.9	5.7	>10.4	7.5	XU3, XU4 primary to secondary
G	2 MOOP	IIIb	240	376	4.8	4.6	8.6	8.6	IC703, IC704, IC705 primary to secondary pads (-Nx* only)
H	2 MOOP	IIIb	337	616	7.0	5.3	10.9	10.9	TX701 pads to TX701A pads (-Nx* only)
I	2 MOOP	IIIb	310	412	6.6	4.6	8.2	8.2	XF701 to TX701A pin1 (-Nx* only)
I	2 MOOP	IIIb	240	374	4.8	4.6	8.7	8.7	XD8 track to XR37 tracks
J	2 MOPP	IIIb	240	374	7.9	5.0	8.7	8.7	XD8 track to XR37 tracks (-M, -MR only)
J	2 MOPP (NV1-1G000-M)	IIIb	240	374	7.9	5.7	8.7	8.7	XD8 track to XR37 tracks
Z	1 MOOP	IIIb	240	340	2.4	2.3	4.3	4.3	C2 pin 1 flood to 2 earth pad
Z	1 MOOP (NV1-1G000-M)	IIIb	240	340	4.0	2.9	4.3	4.3	C2 pin 1 flood to 2 earth pad
Z	1 MOOP (K10142x)	IIIb	240	340	4.0	2.5	4.3	4.3	C2 pin 1 flood to 2 earth pad
Supplementary information: Creepage and Clearance distances have been calculated appropriately using tables 8, 12, 13, 15 and 16. CTL Decision DSH 0791 has been applied for use of the '>' sign. Input to PE changed to 1 MOPP for -M and -MR options.									