

Industries & Applications

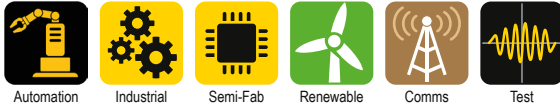

Features & Benefits

- ▶ **AC or DC operation** enables use in a wide range of applications.
- ▶ **130% boost power capability** increases design flexibility and enable system retrofits.
- ▶ **Efficiencies of up to 94.1%** contribute to minimised energy consumption and an environmentally friendly energy footprint.
- ▶ **A peak inrush energy less than 0.6A²s** prevents input circuit breakers from nuisance tripping.
- ▶ **Push-in terminals** for tool-less installation and high vibration resistance.
- ▶ **Dedicated models with coated PCBs** to withstand harsh environments.
- ▶ **A sophisticated thermal design** for minimal installation clearances.



Technical data abstract¹

Output voltage	<i>nom.</i>	48V _{DC}
Adjustment range	<i>nom.</i>	45 .. 57V _{DC}
Output current	<i>nom.</i>	5A
Boost current	<i>max.</i>	6.5A
Hold-up time	<i>min.</i>	25ms
Overload behaviour		CC + Intermittent mode (Hiccup)
Input voltage AC	<i>nom.</i>	100 .. 240V _{AC}
	<i>max.</i>	90 .. 264V _{AC}
Frequency range	<i>max.</i>	47 .. 63HZ
Inrush current AC ²	<i>typ.</i>	12 / 15 / 35A <1ms
Inrush energy AC ²	<i>typ.</i>	0.06 / 0.10 / 0.55A ² s
Input voltage DC	<i>nom.</i>	110 .. 250V _{DC}
	<i>max.</i>	93 .. 300V _{DC}
Inrush current DC	<i>typ.</i>	13 / 35A <2ms
Inrush energy DC	<i>typ.</i>	0.1 / 0.8A ² s
Output power	<i>nom.</i>	240W
Boost power	<i>max.</i>	312W / 10s
Conversion efficiency ²	<i>typ.</i>	92.7 / 93.2 / 94.1%
Power losses ²	<i>typ.</i>	18.9 / 17.5 / 15.0W
No-load consumption ²	<i>max.</i>	3.9 / 3.6 / 2.2W
Power factor	<i>typ.</i>	0.95
Ambient operating temperature	<i>nom.</i>	-25 .. +55°C _{amb} (-13 .. +158°F _{amb})
	<i>max.</i>	-25 .. +70°C _{amb} (-13 .. +131°F _{amb})
Service life MTBF ³	<i>min.</i>	7.89M / 2.79M hrs
Service lifetime ²	<i>min.</i>	131400hrs
Width x Height x Depth		44x125x127mm (1.50x4.92x5.00in)
Weight	<i>max.</i>	615g (1.36lb)

¹All values refer to STC unless otherwise stated | ²100 / 120 / 240V_{AC}, 25°C_{amb} | ³50% / 100% P_{out,nom}

Certifications & Approvals



IEC EN 61010-1
IEC EN 61010-2-201
IEC EN 62368-1 (Ed.3)



UL CSA 61010-1
UL CSA 61010-2-201
E356563



UL CSA 62368-1 (Ed.3)
E511889



IS 13252-1
R-41185469

Compliance & Registration



EU Low Voltage Dir. 2014/35/EU
EU EMC Dir. 2014/30/EU
EU RoHS Dir. 2011/65/EU



Safety and EMC Reg. 2016
Hazard. Substances Reg. 2012



For China RoHS information refer to the
[TDK website](#)

CAE catalogues



Commercial information

Order codes	D1SE240-48-A4 D1SE240-48-A5
TARIC code	8504408390
Life-cycle status	Launch
Product revision	F01
Single package	
Width	172mm (6.77in)
Height	84.5mm (3.33in)
Depth	145mm (5.71in)
Gross weight	730g (1.61lb)
Bulk package	
Width	310mm (5.71in)
Height	193mm (7.60in)
Depth	460mm (18.11in)
Quantity	10 units
Pallet	
Width	1020mm (40.16in)
Length	1090mm (42.91in)
Quantity	300 units
Manufacturer warranty	3 years

Model selector

Model name	Output Power	Output Voltage	Feature
D1SE120-12-A4	120W	12V _{DC}	DC OK
D1SE120-12-A5	120W	12V _{DC}	DC OK, PCB coating
D1SE120-24-A3	120W	24V _{DC}	
D1SE120-24-A4	120W	24V _{DC}	DC OK
D1SE120-24-A5	120W	24V _{DC}	DC OK, PCB coating
D1SE240-24-A3	240W	24V _{DC}	
D1SE240-24-A4	240W	24V _{DC}	DC OK
D1SE240-24-A5	240W	24V _{DC}	DC OK, PCB coating
D1SE240-48-A4	240W	48V _{DC}	DC OK
D1SE240-48-A5	240W	48V _{DC}	DC OK, PCB coating
D1SE480-24-A3	480W	24V _{DC}	
D1SE480-24-A4	480W	24V _{DC}	DC OK
D1SE480-24-A5	480W	24V _{DC}	DC OK, PCB coating
D1SE480-48-A4	480W	48V _{DC}	DC OK
D1SE480-48-A5	480W	48V _{DC}	DC OK, PCB coating
D1SE480-72-A4	480W	72V _{DC}	DC OK
D1SE480-72-A5	480W	72V _{DC}	DC OK, PCB coating

Add-ons and accessories



DDSM programmable DC/DC converter

Isolated buck-boost converter with a wide input/output voltage range.

DDSM120-0555-R0

5A output at 5..55V, input 11..52V, push-in terminals, display, DC OK, USB

DDSM240-0555-R0

10A output at 5..55V, input 11..52V, push-in terminals, display, DC OK, USB

www.emea.lambda.tdk.com/uk/products/ddsm



DDA DC/DC converter

Non-isolated step-down converter for creating additional DC bus voltages from a single DC input source.

DDA250

Single output 20A at 3.3..15V, input 9..53V, DC OK LED, screw terminals

DDA325

Dual output 14A at 3.3..24V and 8A at -3.3..-24V, input 9..40V, DC OK LEDs, screw terminals

DDA500

Dual output 2x20A at 3.3..15V, input 9..53V, DC OK LEDs, screw terminals

www.emea.lambda.tdk.com/uk/products/dda



DUSH DC-UPS

In mission critical applications, the DUSH serves as a backup solution to deliver power from a battery.

DUSH960-1248-0M

20A input/output/battery, 12..48V programmable, buck-boost converter, battery interface, Modbus/RTU, LCD, 5A AUX output, push-in terminals

DUSH960-1248-1M

20A input/output/battery, 12..48V programmable, buck-boost converter, battery interface, Modbus/RTU, LED indication, push-in terminals

www.emea.lambda.tdk.com/uk/products/dush

Index

1.	General.....	6
2.	Electrical output.....	7
3.	Electrical input AC.....	8
4.	Electrical input DC.....	9
5.	Performance.....	10
6.	Ambient conditions.....	11
7.	Reliability and Service lifetime.....	13
8.	Dimensions & Mechanical data.....	14
9.	Installation clearances.....	15
10.	Wiring & Connection.....	15
11.	Signaling & Control.....	16
12.	Block diagram.....	16
13.	Device protection.....	17
14.	Electrical Safety.....	17
15.	Electromagnetic immunity.....	19
16.	Electromagnetic emission.....	19
17.	Certifications & Approvals.....	20
18.	Designed to meet.....	20
19.	Compliance & Registration.....	21
20.	Application notes.....	21

List of abbreviations

avg.	<i>average</i>	The arithmetic average calculated from a row of values.
CC		Constant output current
CGD		Corner grounded delta (AC power system)
chap.		Chapter
Dir.		Directive
eCap		Electrolytic capacitor
EMC		Electromagnetic Compatibility
ES		Electrical Energy Source
HIPOT		High Potential Test
Iac		AC input current under a particular operating condition
Iout		DC output current under a particular operating condition
Iout_boost		Available current reserve beyond Iout_nom (w/o a drop in Uset) that can be delivered for a limited time.
Iout_nom		Continuous nominal DC output current under STC.
Iout_ol		Max. intermittent DC output current in an overload situation and a shortfall of Uset.
Iout_sc		Max. short circuit DC output current and Uout close to zero.
ITU		International Telecommunication Union
max.	<i>maximum</i>	The maximum value which a parameter can assume, or which must not be exceeded.
MCB		Miniature circuit breaker
min.	<i>minimum</i>	The minimum value which a parameter can assume, or must not be fallen below.
MOV		Metal Oxide Varistor
MTBF		Mean Time Between Failure
nom.	<i>nominal</i>	The ideal or reference value of a technical parameter which is guaranteed under STC. All nominal values in this document refer to each other and represent the general specification of the device.
OCP		Overcurrent protection
OTP		Overtemperature protection
OVP		Overvoltage protection
PCB		Printed Circuit Board
PELV		Protective Extra Low Voltage
PE		Protective Earth
PFC		Power Factor Correction
Pout		Output power under a particular operating condition with reference to Pout_nom
Pout_boost		Available power reserve beyond Pout_nom that can be delivered for a limited time.
Pout_nom		Nominal output power
PSU		Power supply unit
Reg.		Regulation
SELV		Safety Extra Low Voltage
STC		Standard test conditions (see „1. General“ on page 6)
typ.	<i>typical</i>	The typical value of a parameter is not guaranteed but can be assumed under STC. The min. or max. value must be determined during the engineering process of the end application.
Uout		DC output voltage under a particular operating condition
Uout_nom		Nominal DC output voltage
Uset		Manually set output voltage via voltage potentiometer
UVP		Undervoltage protection
Vac		AC input voltage under a particular operating condition
Vac_nom		Nominal AC input voltage
/		Separator between two values. The conditions to which the values refer can be found in the last column of the table.
..		Specifies a range of values.
<		The parameter is less than or equal to the specified value
>		The parameter is greater than or equal to the specified value

Table data structure

X. Technical category

Technical parameter	Characteristic (optional)	Values	Condition (optional)
---------------------	---------------------------	--------	----------------------

Unless otherwise stated, all values are specified in normal mounting position, at full load, nominal input and output voltages, 25°C (77°F) ambient temperature and a run-in time of 5 minutes.

1. General

Proper handling of the product

The faultless and safe operation of the products requires proper transport, proper storage, set-up, assembly, installation, commissioning, operation and maintenance. The permissible ambient conditions must be observed. Instructions in the associated documentation must be observed.

Protection enclosure required

The device must be installed in a protective housing or control cabinet to which only qualified personnel have access.

Humid environments

Do not operate the device in a damp environment or in an environment where condensation is likely to occur.

Switch or circuit-breaker mounting position

A switch or circuit-breaker must be mounted near the equipment.

Observe country-specific regulations

In addition to the product documentation, the relevant country-specific regulations for the installation of the device must be observed.

Prohibited electrical/mechanical modifications

The product must not be modified in any way electrically or mechanically. Modifications can result in fatal injuries and damage to property.

Expiry of the manufacturer's warranty

The power supply is maintenance-free. Repairs can only be carried out by the manufacturer. Opening the housing voids the manufacturer's warranty.

Use of third-party products

If third-party products and components are used for power or voltage increase, buffering (primary or secondary side), EMC filtering, redundancy or for load protection, it must be approved by TDK-Lambda.

Standard test conditions

Unless otherwise stated, all values are specified in normal mounting position, at full load, nominal input and output voltages, 25°C (131°F) ambient temperature and a run-in time of 5 minutes.

1.1 Description of user elements

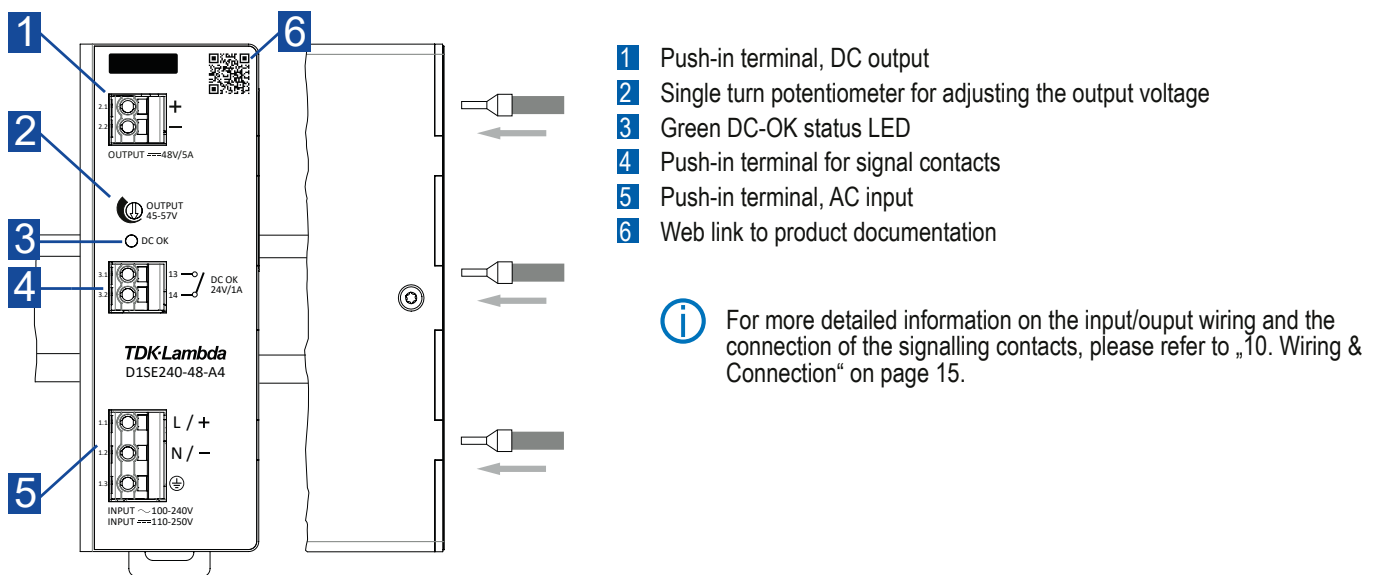

Fig. 1: Description of user elements

2. Electrical output

Output voltage [U _{out_nom}]	nom.	48V _{DC}	
Adjustment range [U _{set}]	nom.	45..57V _{DC}	
Adjustment tolerance	max.	±3%	at upper/lower end position of voltage potentiometer
Factory default		48V _{DC} (±0.5%)	
Output current [I _{out_nom}]	nom.	5A	
Boost current [I _{out_boost}]	max.	6.5A / 10s	< 55°C _{amb}
Overload behaviour		Constant current + Intermittent mode (Hiccup)	see Fig. 3
Short-circuit proof		Yes, auto-recovery	
Instant SC current [I _{out_sc}]	max.	28A <1ms	
SC hiccup current	max. avg.	24A / 20ms 3A / 10s	
Start-up delay	typ.	0.9s	
Rise time	typ. typ.	12ms 18ms	0% P _{out_nom} 100% P _{out_nom} , resistive load
Voltage overshoot	typ.	0.1V _{DC}	
Fall time	typ.	37ms	
Hold-up time	min.	25ms	100..240V _{AC}
Output capacitance	max.	2720µF	
Capacitive load start-up	max.	5000µF	22.5..29V _{DC}
Feedback voltage	max.	61V _{DC}	
Feedback energy	max.	1.92J	
Return current	max.	30mA	OFF mode
Line regulation	max.	0.01%	90..264V _{AC}
Load regulation	max.	0.07%	90..264V _{AC}
Dynamic response	typ.	240mVpp	90..264V _{AC} , 10..100% P _{out_nom} , transient frequency 10Hz
Ripple & noise voltage*	max. max.	35mVpp 45mVpp	90..264V _{AC} , +25..+70°C _{amb} 90..264V _{AC} , -25..+25°C _{amb}

*The measurement was performed with a short twisted pair cable using a 120µF eCap and a 0.1µF cCap connected in parallel. A bandwidth limit of 20MHz is required.

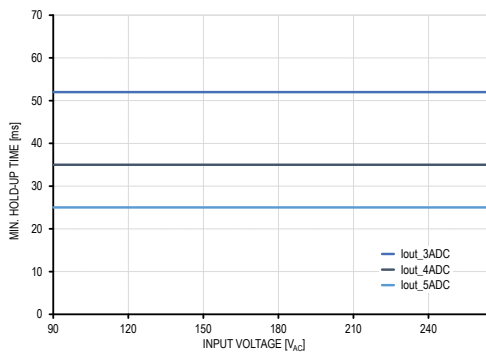

Fig. 2: Hold-up times under different load conditions as a function of the input voltage

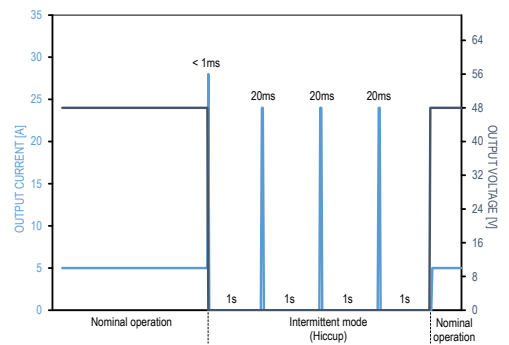

Fig. 3: Typical short circuit behavior

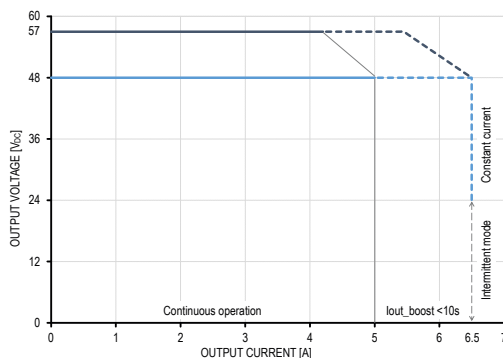

Fig. 4: Boost current capability up to 55°C_{amb}

Unless otherwise stated, all values are specified in normal mounting position, at full load, nominal input and output voltages, 25°C (77°F) ambient temperature and a run-in time of 5 minutes.

3. Electrical input AC

AC power systems		TT, TN, IT, CGD	
Input voltage [U _{in_nom}]	<i>nom.</i>	100..240V _{AC}	1AC, N, PE
Input voltage [U _{in_max}]	<i>max.</i>	90..264V _{AC}	
Withstand voltage	<i>max.</i>	300V _{AC} / 30s	
Mains frequency	<i>nom.</i>	50/60Hz	
Frequency range	<i>max.</i>	47..63Hz	
Input current	<i>max.</i>	5.6A	100..240V _{AC} ±10%
Input current RMS	<i>typ.</i>	2.6A	100V _{AC}
	<i>typ.</i>	2.2A	120V _{AC}
	<i>typ.</i>	1.2A	240V _{AC}
Crest factor	<i>typ.</i>	1.6	100V _{AC}
	<i>typ.</i>	1.6	120V _{AC}
	<i>typ.</i>	1.7	240V _{AC}
Turn-ON voltage	<i>typ.</i>	80V _{AC}	
Turn-OFF voltage	<i>typ.</i>	80V _{AC}	
Input capacitance	<i>max.</i>	150μF	
Inrush current	<i>typ.</i>	12A <1ms	100V _{AC} , 25°C _{amb} , cold start
	<i>typ.</i>	15A <1ms	120V _{AC} , 25°C _{amb} , cold start
	<i>typ.</i>	35A <1ms	240V _{AC} , 25°C _{amb} , cold start
Inrush energy	<i>typ.</i>	0.06A ² s	100V _{AC} , 25°C _{amb} , cold start
	<i>typ.</i>	0.10A ² s	120V _{AC} , 25°C _{amb} , cold start
	<i>typ.</i>	0.55A ² s	240V _{AC} , 25°C _{amb} , cold start

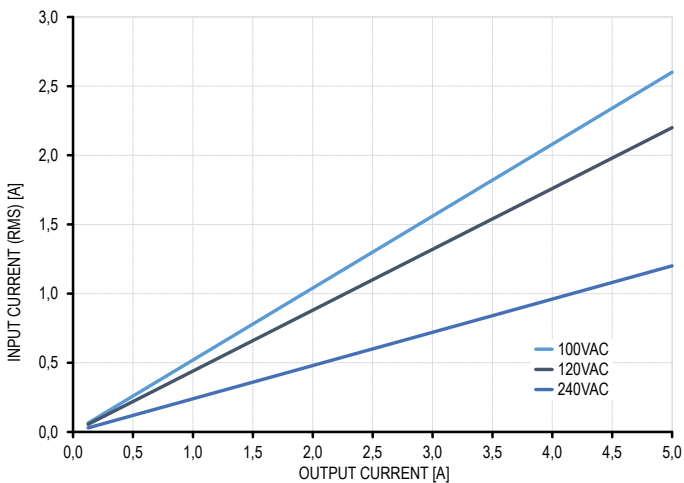

Fig. 5: Typical AC input current as a function of the output current

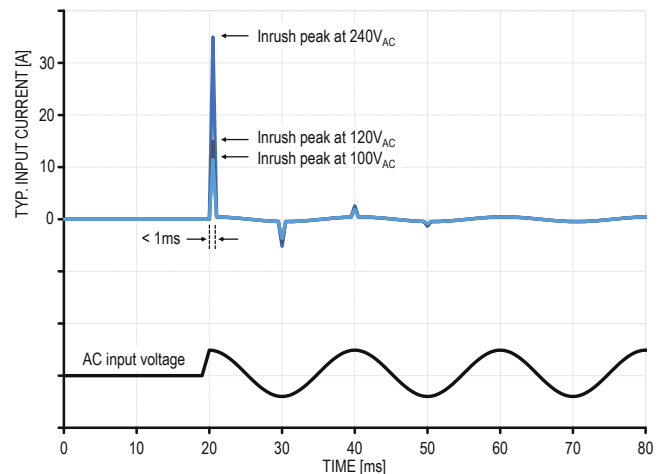

Fig. 6: Inrush current and energy during start-up phase

4. Electrical input DC

Input voltage	<i>nom.</i> 110 .. 250V _{DC} <i>max.</i> 93 .. 300V _{DC}	external DC fuse required, see "Device protection" on page 17
Withstand voltage	<i>max.</i> 420V _{DC} / 30s	
Input current	<i>max.</i> 3A	
Turn-ON voltage	<i>typ.</i> 105V _{DC}	
Turn-OFF voltage	<i>typ.</i> 60V _{DC}	
Inrush current	<i>typ.</i> 13A <2ms <i>typ.</i> 35A <2ms	110V _{DC} , 25°C _{amb} , cold start 250V _{DC} , 25°C _{amb} , cold start
Inrush energy	<i>typ.</i> 0.1 A ² s <i>typ.</i> 0.8 A ² s	110V _{DC} , 25°C _{amb} , cold start 250V _{DC} , 25°C _{amb} , cold start

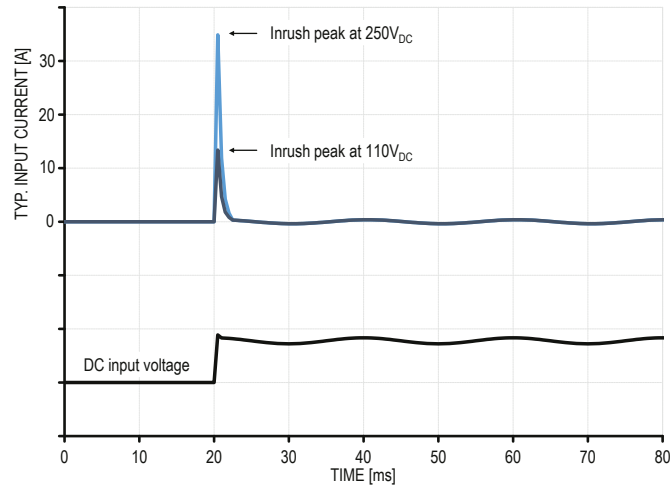

Fig. 7: DC inrush current and energy during start-up phase

5. Performance

Output power [P _{out_nom}]	nom.	240W	
Boost power [P _{out_boost}]	max.	312W / 10s	90 .. 264V _{AC}
Duty cycle	max.	0.016	90 .. 264V _{AC} , 55°C _{amb}
Power factor	typ.	0.95	
Active input power	typ.	258.9W	100V _{AC}
	typ.	257.5W	120V _{AC}
	typ.	255.0W	240V _{AC}
Reactive input power	typ.	85.1Var	100V _{AC}
	typ.	84.6Var	120V _{AC}
	typ.	83.8Var	240V _{AC}
Apparent input power	typ.	272.5VA	100V _{AC}
	typ.	271.1VA	120V _{AC}
	typ.	268.5VA	240V _{AC}
Conversion efficiency	typ.	92.7%	100V _{AC} , 100% P _{out_nom}
	typ.	93.2%	120V _{AC} , 100% P _{out_nom}
	typ.	94.1%	240V _{AC} , 100% P _{out_nom}
	avg.	91.4%	100V _{AC} , 25..100% P _{out_nom}
	avg.	91.7%	120V _{AC} , 25..100% P _{out_nom}
	avg.	91.8%	240V _{AC} , 25..100% P _{out_nom}
Power losses	typ.	18.9W	100V _{AC} , 100% P _{out_nom}
	typ.	17.5W	120V _{AC} , 100% P _{out_nom}
	typ.	15.0W	240V _{AC} , 100% P _{out_nom}
	avg.	22.6W	100V _{AC} , 25..100% P _{out_nom}
	avg.	21.7W	120V _{AC} , 25..100% P _{out_nom}
	avg.	21.4W	240V _{AC} , 25..100% P _{out_nom}
No-load consumption	max.	3.9W	100V _{AC} , 0% P _{out_nom}
	max.	3.6W	120V _{AC} , 0% P _{out_nom}
	max.	2.2W	240V _{AC} , 0% P _{out_nom}

*Average efficiency under 25%, 50%, 75% and 100% load conditions, according to eco-design requirements of EU commission regulation 2019/1782.

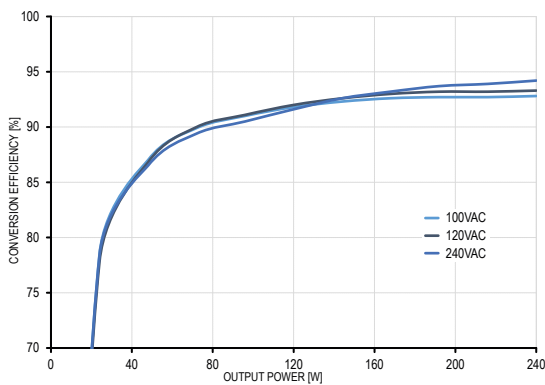

Fig. 8: Conversion efficiency as a function of the output power

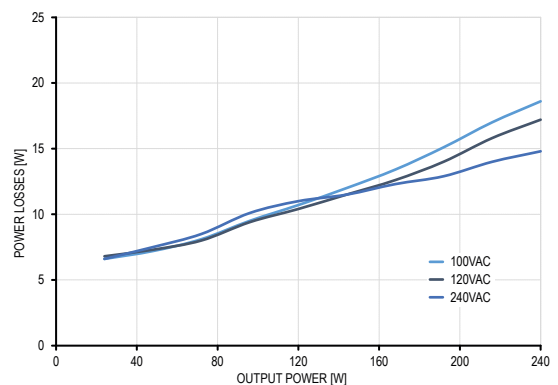

Fig. 9: Power losses as a function of the output power

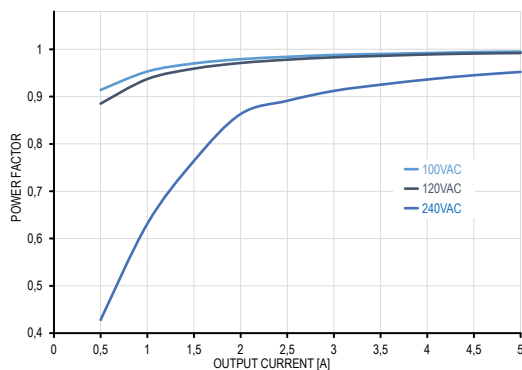

Fig. 10: Power factor as a function of the output current

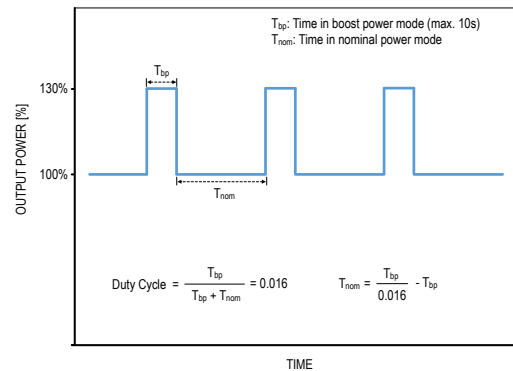

Fig. 11: Period and frequency of use of boost power at 55°C_{amb} in normal mounting position

Unless otherwise stated, all values are specified in normal mounting position, at full load, nominal input and output voltages, 25°C (77°F) ambient temperature and a run-in time of 5 minutes.

6. Ambient conditions

Ambient operating temperature	<i>nom.</i>	-25 .. +55°C _{amb} (-13 .. +131°F _{amb})	normal mounting position
	<i>max.</i>	-25 .. +70°C _{amb} (-13 .. +158°F _{amb})	
Start-up temperature	<i>max.</i>	-40°C (-40°F)	
Ambient storage temperature	<i>max.</i>	-40 .. +85°C _{amb} (-40 .. +185°F _{amb})	
Power derating*	<i>min.</i>	2.4W/°C _{amb} (2.22W/°F _{amb})	120V _{AC} , >55°C _{amb} (131°F _{amb})
	<i>min.</i>	6.4W/°C _{amb} (3.56W/°F _{amb})	120V _{AC} , >55°C _{amb} (131°F _{amb}), 90° rotated
	<i>min.</i>	2.4W/°C _{amb} (1.33W/°F _{amb})	120V _{AC} , >55°C _{amb} (131°F _{amb}), 180° rotated
	<i>min.</i>	0.8W/°C _{amb} (0.44W/°F _{amb})	240V _{AC} , >55°C _{amb} (131°F _{amb})
	<i>min.</i>	4.8W/°C _{amb} (2.67W/°F _{amb})	240V _{AC} , >55°C _{amb} (131°F _{amb}), 90° rotated
	<i>min.</i>	0.8W/°C _{amb} (0.44W/°F _{amb})	240V _{AC} , >55°C _{amb} (131°F _{amb}), 180° rotated
Cooling concept		Natural convection	
Relative storage humidity IEC 60068-2-30	<i>max.</i>	95%	non-condensing
Relative operation humidity IEC 60068-2-30	<i>max.</i>	95%	non-condensing
Operating altitude	<i>nom.</i>	3000mASL (9842ftASL)	
	<i>max.</i>	6000mASL (19685ftASL)	not UL approved, reduced OVC
Percentage power derating	<i>min.</i>	5% per 1000m (3281ft)	>3000mASL (>9842ftASL)
Temperature derating	<i>min.</i>	5K per 1000m (9K per 2181ft)	>3000mASL (>9842ftASL)
Atmospheric pressure	<i>nom.</i>	689hPa	
	<i>max.</i>	469 .. 1070hPa	
Pollution degree		2	
Vibration sinusoidal IEC 60068-2-6		2g / 10 .. 500Hz, 1 hour/direction X,Y,Z	mounted on DIN rail
Shock test sinusoidal halfwave IEC 60068-2-27		30g / 11ms ±5ms, 3 bumps/direction, 9 bumps total	mounted on DIN rail
Audible noise		Some audible noises may be heard during no load, overload or short circuit.	

*Not actively controlled

i For altitudes above 3000mASL (9842ftASL) the next lower OVC must be considered.

i **Flowing mixed gases**
The power supplies with conformally coated PC boards have been type tested according to IEC EN 60068-2-60 - Test Ke: Flowing mixed gas corrosion test. During the inspection after the exposure, no signs of corrosion have been detected.

i **Salt mist**
The power supplies with conformally coated PC boards have been type tested according to IEC 60068-2-11 - Test Ka: Salt mist. No functional impairments were detected after the test was carried out.

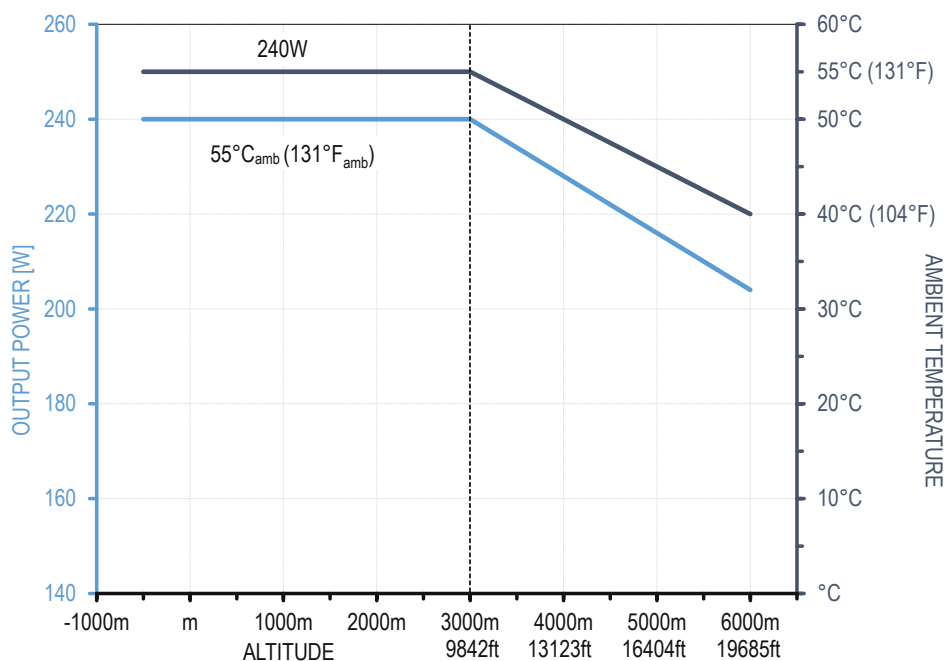

Fig. 12: Output power and ambient temperature derating at increasing altitudes

Unless otherwise stated, all values are specified in normal mounting position, at full load, nominal input and output voltages, 25°C (77°F) ambient temperature and a run-in time of 5 minutes.

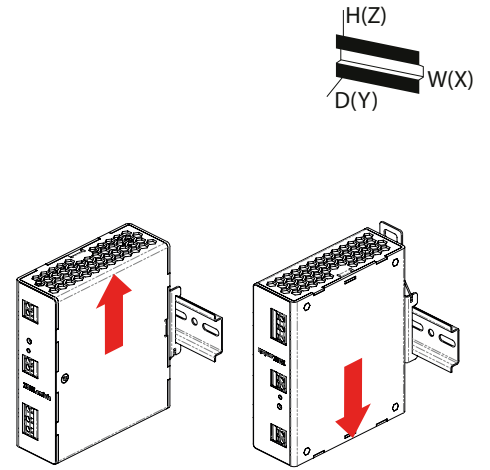
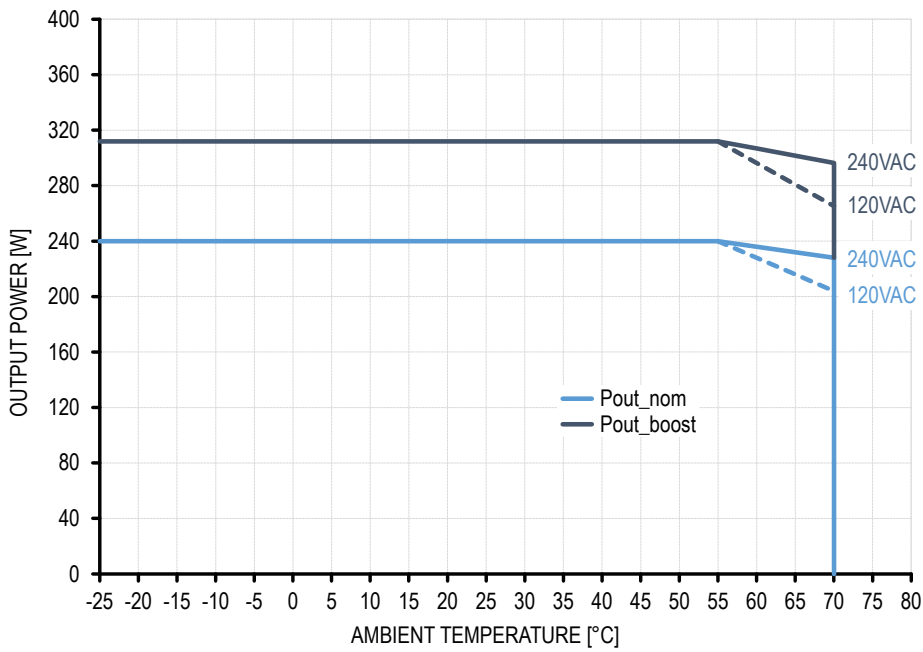

Fig. 13: Available output power as a function of the ambient temperature for normal and 180° rotated mounting positions

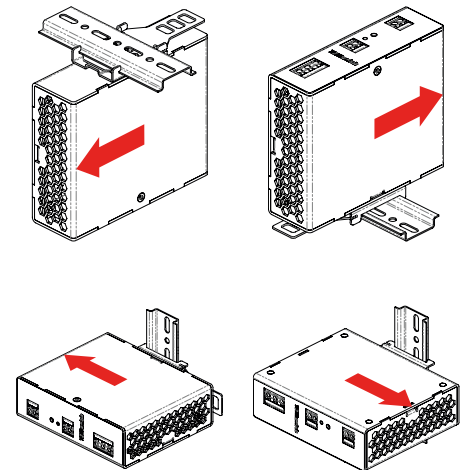
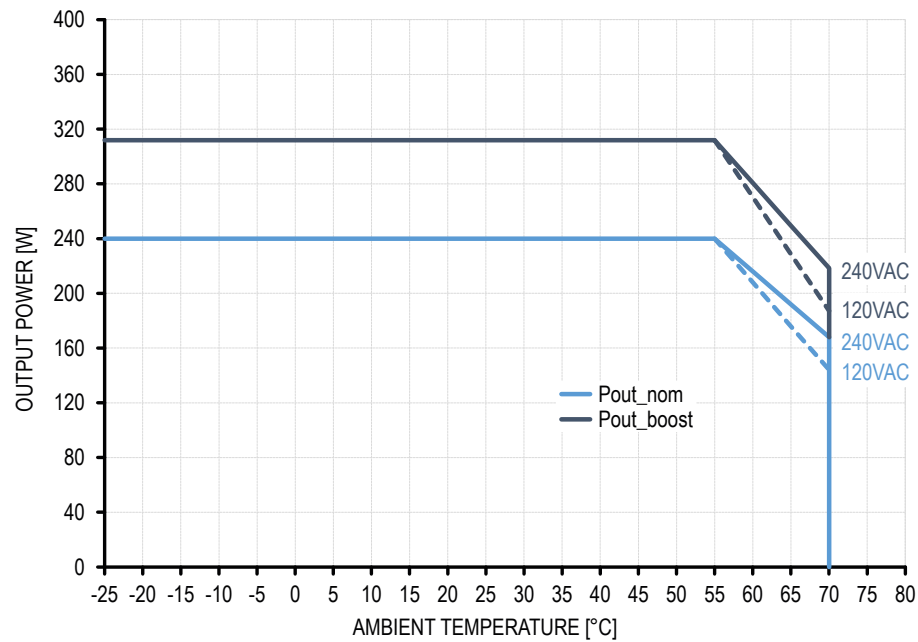

Fig. 14: Available output power as a function of the ambient temperature for 90° rotated mounting position

Unless otherwise stated, all values are specified in normal mounting position, at full load, nominal input and output voltages, 25°C (77°F) ambient temperature and a run-in time of 5 minutes.

7. Reliability and Service lifetime

The service lifetime of the power supply is determined primarily by the electrolytic capacitors utilised. The values provided herein are calculated estimates, and as such, do not represent guaranteed lifetimes. The calculation is based on the respective capacitor manufacturer's method, taking into account ripple current, operating frequency, and capacitor temperature under the herein specified operating conditions. It is important to note that, due to the theoretical nature of the calculation, all capacitor manufacturers specify a maximum expected service lifetime of 15 years.

TDK-Lambda applies strict component selection criteria and utilises electrolytic capacitors exclusively from reputable manufacturers such as Murata, Nippon Chemi-Con, Nichicon, Rubycon, and TDK.

Service lifetime	<i>min.</i>	117 000hrs	100VAC, 100% P _{out_nom} , 40°C _{amb} , 24/7
	<i>min.</i>	131 400hrs	120VAC, 100% P _{out_nom} , 40°C _{amb} , 24/7
	<i>min.</i>	131 400hrs	240VAC, 100% P _{out_nom} , 40°C _{amb} , 24/7
	<i>min.</i>	131 400hrs	100VAC, 75% P _{out_nom} , 40°C _{amb} , 24/7
	<i>min.</i>	131 400hrs	120VAC, 75% P _{out_nom} , 40°C _{amb} , 24/7
	<i>min.</i>	131 400hrs	240VAC, 75% P _{out_nom} , 40°C _{amb} , 24/7
	<i>min.</i>	131 400hrs	100VAC, 100% P _{out_nom} , 25°C _{amb} , 24/7
	<i>min.</i>	131 400hrs	120VAC, 100% P _{out_nom} , 25°C _{amb} , 24/7
Early life MTBF Telcordia SR-332 Issue 4	<i>min.</i>	0.62M hrs	70°C _{amb} , 50% P _{out_nom}
	<i>min.</i>	1.30M hrs	40°C _{amb} , 50% P _{out_nom}
	<i>min.</i>	1.49M hrs	25°C _{amb} , 50% P _{out_nom}
	<i>min.</i>	0.48M hrs	70°C _{amb} , 100% P _{out_nom}
	<i>min.</i>	1.00M hrs	40°C _{amb} , 100% P _{out_nom}
Service life MTBF Telcordia SR-332 Issue 4	<i>min.</i>	1.08M hrs	70°C _{amb} , 50% P _{out_nom}
	<i>min.</i>	5.20M hrs	40°C _{amb} , 50% P _{out_nom}
	<i>min.</i>	7.89M hrs	25°C _{amb} , 50% P _{out_nom}
	<i>min.</i>	0.68M hrs	70°C _{amb} , 100% P _{out_nom}
	<i>min.</i>	2.08M hrs	40°C _{amb} , 100% P _{out_nom}
	<i>min.</i>	2.79M hrs	25°C _{amb} , 100% P _{out_nom}

 The maximum service lifetime guaranteed by the eCap manufacturer is 131 400hrs (15 years). All values above are theoretically calculated.

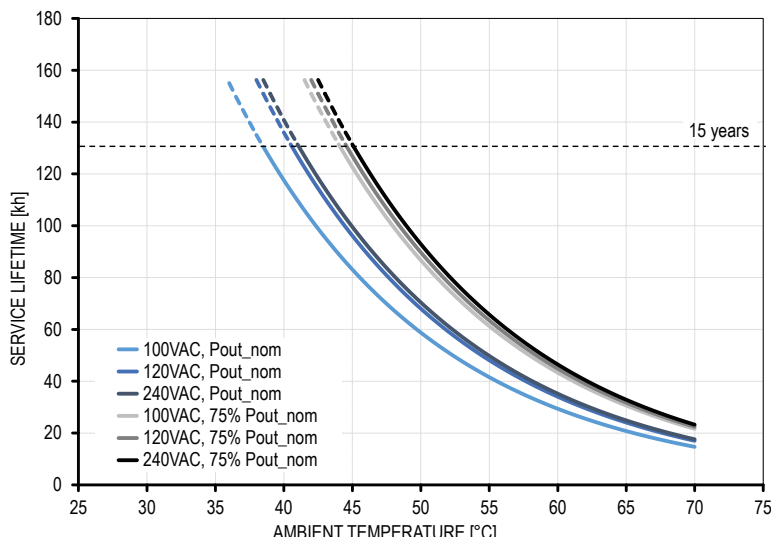

Fig. 15: Power supply expected service lifetime in dependence of ambient temperature

8. Dimensions & Mechanical data

Enclosure material	Aluminum	
Cover material	Aluminum	
Inflammability class UL 94	V0	incl. connection terminals
Width	44mm (1.50in)	
Height	125mm (4.92in)	
Depth	127mm (5.00in)	w/o DIN rail
Built-in width	<i>min.</i> 44mm (1.50in)	
Built-in height	<i>min.</i> 185mm (7.28in)	
Weight	<i>max.</i> 615g (1.36lb)	
Lever arm	<i>max.</i> 53.3mm (2.10in)	into the direction of Y axis
Torsional moment on DIN rail	<i>max.</i> 0.32Nm (2.86lb in)	
Enclosure openings	<i>max.</i> 7mm (0.28in)	
DIN rail types IEC 60715	TH 35-7.5, TH 35-15	

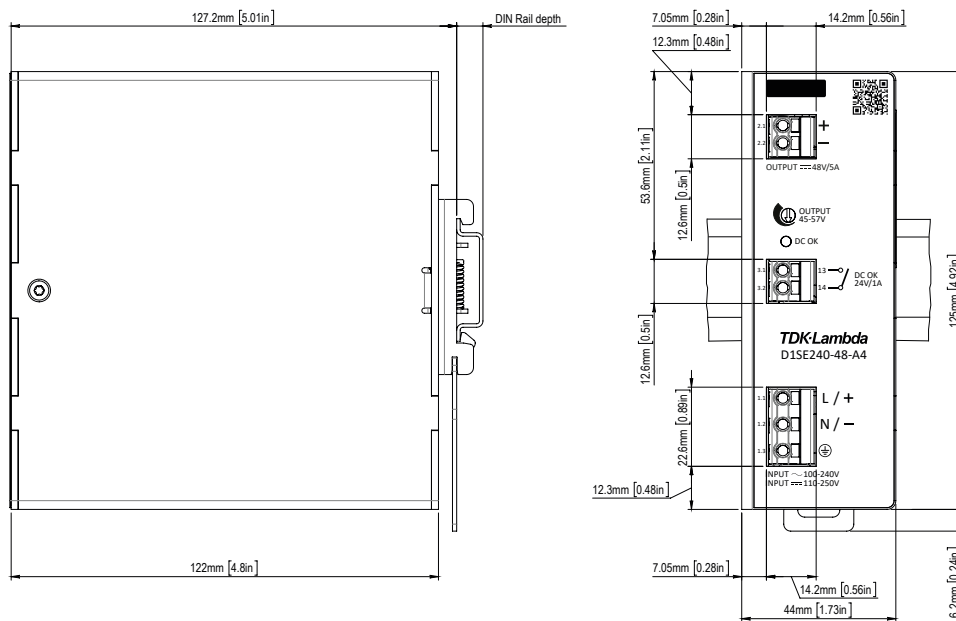

Fig. 16: Dimension drawing of D1SE240-24-A4/-A5

9. Installation clearances

Vertically (Z axis)

Top side	1	min.	40mm (1.57in)
Bottom side	2	min.	20mm (0.79in)

installation above heat sources not permitted

Horizontally (X axis)

Left side / Right side	3a 4a	min.	10mm (0.39in)
Left side / Right side	3b 4b	min.	0mm (0in)

to heat sources (same power rating)
to passive components

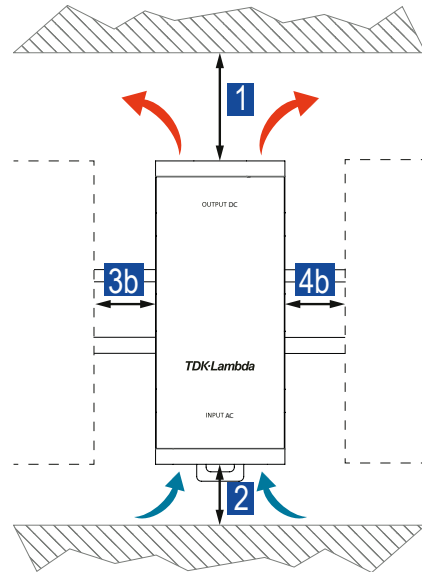
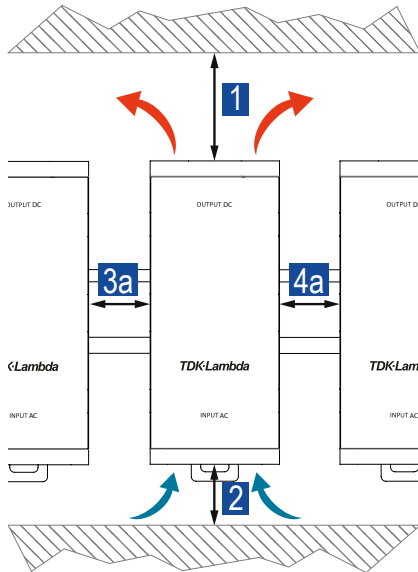

Fig. 17: Installation clearances to heat sources

Fig. 18: Installation clearances to passive components

10. Wiring & Connection

	Input	Output	Signaling
Terminal type	Push-in	Push-in	Push-in
Recommended screw driver	SL 0.5x3mm (SL 1/64 x 1/8in)	SL 0.5x3mm (SL 1/64 x 1/8in)	SL 0.5x3mm (SL 1/64 x 1/8in)
Solid wire	0.2-4.0mm ² (26-12AWG)	0.2-4.0mm ² (26-12AWG)	0.2-4.0mm ² (26-12AWG)
Flexible wire	0.2-2.5mm ² (26-12AWG)	0.2-2.5mm ² (26-12AWG)	0.2-2.5mm ² (26-12AWG)
Insulated ferrules*	0.2-1.5mm ²	0.2-1.5mm ²	0.2-1.5mm ²
Uninsulated ferrules*	0.2-2.5mm ² (26-14AWG)	0.2-2.5mm ² (26-14AWG)	0.2-2.5mm ² (26-14AWG)
Stripping length	9-10mm (0.35-0.39in)	9-10mm (0.35-0.39in)	9-10mm (0.35-0.39in)

*The ferrules must be selected to match the stripping length.

- i** It is recommended that ferrules are used when working with flexible wires.
- i** In compliance with IEC EN/UL 61010-1, 61010-2-201 appropriate copper wires must be used that withstand operating temperatures of at least 75°C (167°F) in ambients NOT exceeding 40°C (104°F), and 90°C (194°F) in ambients exceeding 40°C (104°F).

11. Signaling & Control

DC OK

Type	Relay contact
Characteristic	N/O
Closing	$U_{out} > 90\% U_{set}$
Opening	$U_{out} < 80\% U_{set}$
Resistive load	<i>nom.</i> 1A
	<i>max.</i> 0.5A
	<i>typ.</i> 0.6V
Trigger hysteresis	

duration max. 13ms
 duration max. 5ms
 24V_{DC}
 60V_{DC}

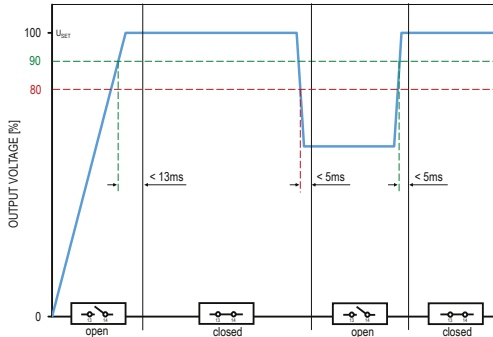

Fig. 19: DC-OK relay status in dependence of output voltage

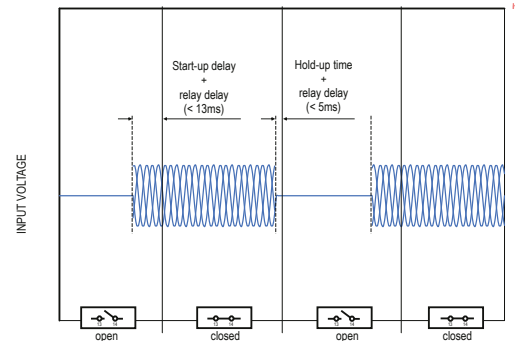

Fig. 20: DC-OK relay status in dependence of input voltage

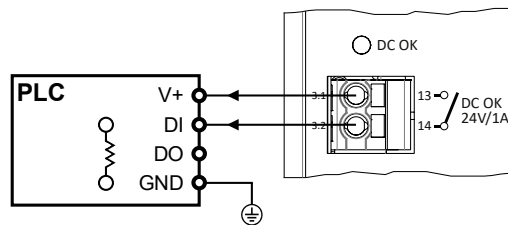

Fig. 21: Generic connection diagram of the DC OK relay contact

12. Block diagram

Active PFC	1	111 .. 222kHz	Dependent on U_{in} and I_{out}
Power stage	2	106 .. 171kHz	Dependent on U_{out} and I_{out}

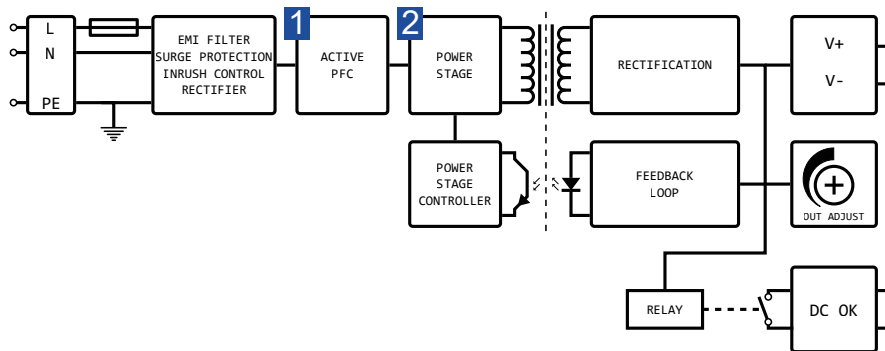



Fig. 22: Block diagram

13. Device protection

Ingress protection degree IEC 60529	IP 20	
NEMA classification NEMA 250-2018	NEMA 1	
Conformal coating UL 746E	Humiseal 1B59LU	
Output overcurrent protection (OCP)	<i>min.</i>	6.5A, auto-recovery
Output overtemperature protection (OTP)		Yes, auto-recovery
Output overvoltage protection (OVP)	<i>max.</i>	61V _{DC} , auto-recovery
Undervoltage protection threshold (UVP)	<i>max.</i>	75V _{AC}
Integrated input fuse	8A at L pin	not DC capable, not user replaceable
Recommended DC fuse UL 248-1, UL 248-4	8A	
Recommended MCB types IEC 60898-1, UL 1077	B or C characteristic, 6/8/10A	
Transient protection	MOV	

 When installed in an end-product, the maximum branch circuit rating must not exceed 20A (IEC UL 62368-1 Ed.3). If the upstream supply provides a higher ampacity than 20A, an external protection device is required.

14. Electrical Safety

Class of protection IEC 61140	I	PE connection required
Electrical energy source classification IEC 62368-1	ES1	
Safety Extra Low Voltage IEC 61010-2-201, IEC 60950-1	SELV	
Protective Extra Low Voltage IEC 60204-1	PELV	Output must be earthed in the end application
Protective ground resistance	<i>max.</i>	28mΩ
Ground leakage current IEC 60990	<i>max.</i>	0.98mA
	<i>max.</i>	1.23mA
Touch current IEC 60990	<i>max.</i>	15μA
	<i>max.</i>	15μA
Overvoltage category IEC 61010-1, IEC 62368-1 (Ed.3)	II	
		<3000mASL (<9842ftASL)

14.1 Overvoltage category design

Underlying IEC standard	61010-1	62368-1 ¹	60950-1	61558-2-16 ²	62477-1	61204-7	60664-1
Mains transient voltage	II	II	III	II	III	III	III
Creepage & Clearance	III	II	III	II	III	III	III

¹ Edition 3

² not applicable along with IEC 61204-7

14.2 Insulation strength

		Type test (60s) IEC 62368-1 IEC 61010-1	Routine test (3s) IEC 61010-1	Field test (3s)
Input / Output	A	5000V _{DC}	4000V _{DC}	4000V _{DC}
Input / PE	B	3100V _{DC}	3100V _{DC}	3100V _{DC}
Input / DC OK	C	3000V _{AC}		4000V _{DC}
Output / PE	D		750V _{DC}	750V _{DC}
Output / DC OK	E	860V _{AC}		750V _{DC}

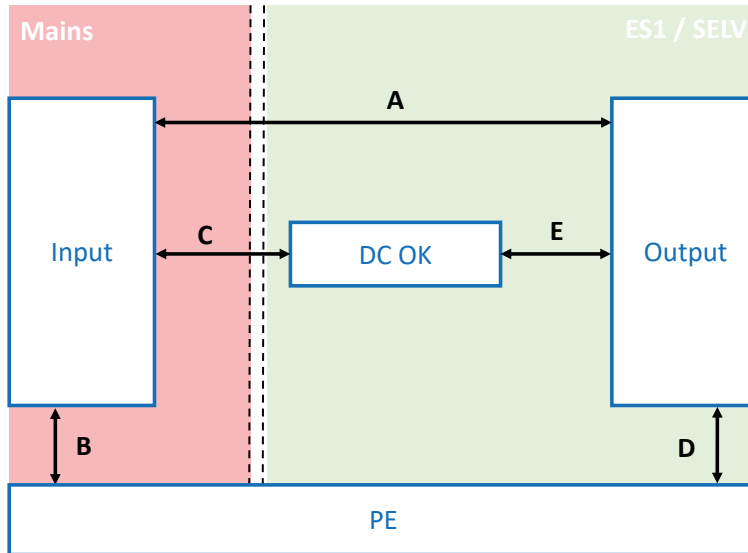

Fig. 23: Schematic of the insulation paths

14.3 HIPOT test

Apart from routine and type test, the end user might need to check the insulation strength during the final inspection and testing to guarantee the electrical safety of the end application. Therefore, a high potential test (HIPOT test) can be performed in the field. The following conditions must be observed:

- ▶ As every HIPOT test causes stress on the power supplies safety insulation, avoid frequent HIPOT testing or excessive test voltages
- ▶ The test voltages and durations, as indicated under „14.2 Insulation strength“ on page 18, must not be exceeded
- ▶ The test voltages rise and fall time should be between 2 and 4 seconds

i According to EN 60204-1 (Safety of machinery - Electrical equipment of machines), an individual HIPOT test of the power supply isn't required. During the HIPOT test of the end application, the power supply can be disconnected and only installed once the test has been completed.

15. Electromagnetic immunity

Investigated under generic standards IEC EN 61000-6-2 (2019) - Immunity for industrial environments.

Electrostatic contact discharge IEC EN 61000-4-2	4kV	Criterion A	330Ω / 150pF
Electrostatic air discharge IEC EN 61000-4-2	8kV	Criterion A	330Ω / 150pF
Electromagnetic RF field¹ IEC EN 61000-4-3	10V/m 3V/m	Criterion A Criterion A	80MHz..1GHz 1.4GHz..6GHz
Fast transients (burst) IEC EN 61000-4-4			
Input ²	4kV	Criterion A	5kHz or 100kHz
Output	2kV	Criterion A	5kHz or 100kHz
Signal contact ²	1kV	Criterion A	5kHz or 100kHz
Surge voltages IEC EN 61000-4-5			
Input symmetrical (L-L) ²	2kV	Criterion A	2Ω+18μF, for $\Phi = 0^\circ, 90^\circ, 180^\circ, 270^\circ$
Input asymmetrical (L-PE) ²	4kV	Criterion A	12Ω+9μF, for $\Phi = 0^\circ, 90^\circ, 180^\circ, 270^\circ$
Output symmetrical (L-L)	2kV	Criterion A	2Ω+18μF
Output asymmetrical (L-PE)	4kV	Criterion A	12Ω+9μF
Signal line asymmetrical (Signal-PE)	1kV	Criterion A	42Ω+0.5μF
Conducted disturbances IEC EN 61000-4-6			
Input, signal line, PE ³	10V	Criterion A	150kHz..80MHz
Power frequency magnetic field IEC EN 61000-4-8	30A/m	Criterion A	50Hz, 60s each axis (x, y, z)
Voltage dips/sags and interruptions IEC EN 61000-4-11, 61000-4-34			
	500ms	Criterion A	230V _{AC} at 70%, 50Hz
	200ms	Criterion A	230V _{AC} at 40%, 50Hz
	20ms	Criterion A	230V _{AC} at 0%, 50Hz
	5000ms	Criterion C	230V _{AC} at 0%, 50Hz
SEMI F47-0706	1000ms	Criterion A	230V _{AC} at 80%, 50Hz
	500ms	Criterion A	230V _{AC} at 70%, 50Hz
	200ms	Criterion A	230V _{AC} at 50%, 50Hz
	20ms	Criterion A	230V _{AC} at 0%, 50Hz

¹ Except for the ITU broadcast frequency bands 87..107MHz, 174..230MHz and 470..790MHz, where the level shall be 3V/m.

² Exceeds the requirements of the European Low Voltage Directive 2014/35/EU

³ Except for the ITU broadcast frequency bands 47..68MHz, where the level shall be 3V.

Performance level definitions:

Criterion A:

The device continues operation as intended during and after the test. The specified performance level accepts a change of $\pm 10\%$ on nominal output voltage and current. There is neither a violation of the performance level, nor a loss of function if the device is used as intended.

Criterion B:

The device continues operation as intended after the test. The specified performance level accepts a change of $\pm 10\%$ on nominal output voltage and current. There is neither a violation of the performance level, nor a loss of function if the device is used as intended. During the test a violation of the performance level is allowed.

Criterion C:

A temporary loss of function is allowed, provided the function is auto-recoverable, or can be restored by the operation of the controls.

16. Electromagnetic emission

Investigated under generic standards IEC EN 61000-6-3 (2021) - Emission standard for residential, commercial and light-industrial environments.

Conducted noise emission input EN 55011, CISPR 11	Class B	150kHz..30MHz
Radiated noise emission input EN 55011, CISPR 11	Class B	30MHz..1GHz
Harmonic currents input IEC EN 61000-3-2	Class A	0kHz..2kHz
Total harmonic distortion (THD) input IEC EN 61000-3-2	17.6%	Order 1..40
Voltage changes, voltage fluctuations and flicker input IEC EN 61000-3-3	PASS	50Hz

Unless otherwise stated, all values are specified in normal mounting position, at full load, nominal input and output voltages, 25°C (77°F) ambient temperature and a run-in time of 5 minutes.

17. Certifications & Approvals



UL 61010-1
CAN/CSA-C22.2 No. 61010-1

Safety requirements for electrical equipment for measurement, control, and laboratory use - Part 1: General requirements

UL 61010-2-201
CAN/CSA-C22.2 No. 61010-2-201

Safety requirements for electrical equipment for measurement, control, and laboratory use - Part 2-201: Particular requirements for control equipment
UL file: E356563

IEC EN 61010-1

Safety requirements for electrical equipment for measurement, control, and laboratory use - Part 1: General requirements

IEC EN 61010-2-201

Safety requirements for electrical equipment for measurement, control, and laboratory use - Part 2-201: Particular requirements for control equipment



IEC EN 62368-1 (Ed.3)

Audio/video, information and communication technology equipment - Part 1: Safety requirements

IEC EN 61558-2-16

Safety of transformers, reactors, power supply units and similar products for supply voltages up to 1100 V - Part 2-16: Particular requirements and tests for switch mode power supply units and transformers for switch mode power supply units



UL 62368-1 (Ed. 3)

Audio/video, information and communication technology equipment - Part 1: Safety requirements
UL file: E511889



IS 13252-1

Information technology equipment - Safety - Part 1: General requirements
Reg. ID: R-41185469

18. Designed to meet

The safety design of the product complies additionally with the following standards.

UL 508	Industrial Control Equipment
IEC 60950-1	Information technology equipment - Safety - Part 1: General requirements
IEC EN 62477-1	Safety requirements for power electronic converter systems and equipment - Part 1: General
IEC EN 61204-3	Low-voltage switch mode power supplies - Part 3: Electromagnetic compatibility
IEC EN 61204-7	Low-voltage switch mode power supplies - Part 7: Safety requirements
EN 60204-1	Safety of machinery - Electrical equipment of machines - Part 1: General requirements
IEC EN 60068-2-60	Test Ke: Flowing mixed gas corrosion test
IEC 60068-2-11	Test Ka: Salt mist

19. Compliance & Registration



Conformity with health, safety, and environmental protection standards for products sold within the European Economic Area (EEA).



UKCA (UK Conformity Assessed) is the product marking that is used for certain goods being placed on the United Kingdom market.



The Waste Electrical and Electronic Equipment Directive (WEEE Directive) is the European Community Directive 2012/19/EU on collection, recycling and recovery targets for all types of electrical goods.



The Restriction of Hazardous Substances Directive 2011/65/EU (RoHS 2) regulates the use of certain hazardous substances in electrical and electronic equipment.



Registration, Evaluation, Authorisation and Restriction of Chemicals (REACH) is a European Union regulation that addresses the production and use of chemical substances, and their potential impacts on both human health and the environment.

20. Application notes

20.1 Parallel operation

The power supplies do not offer a parallel mode for load sharing. Paralleling power supplies to increase power is not recommended.

A 1+1 redundant system can be built by connecting the power supplies in parallel using a decoupling module. The products in the TDK-Lambda DRM series are recommended for this purpose. (refer to chapter "Add-ons and accessories" on page 3)

The following measures must be taken into account when setting up a 1+1 redundant system:

- ▶ Only power supplies of the same series and power rating must be paralleled
- ▶ Load wiring shall be identical in terms of length and cross section
- ▶ The output voltage of the power supplies must be set to the same value
- ▶ The output voltage of each power supply should be checked and maintained in regular intervals
- ▶ All power supplies must be operated under the same ambient conditions
- ▶ The power supplies must not be operated under any condition which requires a power derating (e.g. altitudes above 3000mASL (9842ftASL), temperatures above 55°C_{amb} (131°F_{amb}), mounting orientations others than the normal mounting position, etc.)
- ▶ The increased installation distances must be taken into account when installing the power supplies side by side (see "Installation clearances" on page 15)

i In parallel operations the values of output load regulation, inrush currents, EMI, harmonic and leakage currents will increase.

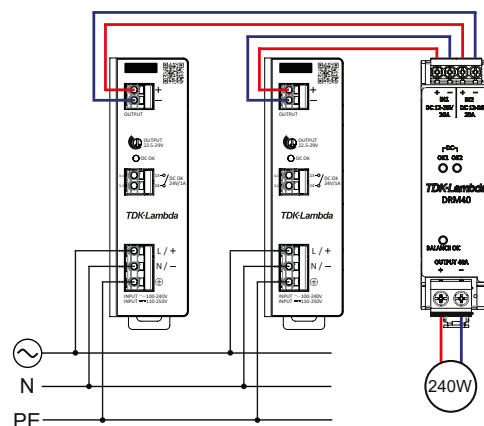

Fig. 24: Connection scheme of power supplies in parallel for the purpose of a 1+1 redundancy

20.2 Series operation

In order to increase the output voltage, it is possible to connect the power supplies in series. The following measures must be taken into account:

- ▶ The output voltage sum must not exceed 250V_{DC}
- ▶ If the output voltage sum exceeds 60V_{DC}, a safeguard against unintended touching must be considered
- ▶ Only power supplies of the same series and power rating must be connected in series
- ▶ All power supplies in series must be operated under the same ambient conditions
- ▶ The power supplies must not be operated under any condition which requires a power derating (e.g. altitudes above 3000mASL (9842ftASL), temperatures above 55°C_{amb} (131°F_{amb}), mounting orientations others than the normal mounting position, etc.)
- ▶ The increased installation clearances must be considered (refer to chapter "Installation clearances" on page 15)

i In series operations the values of output load regulation, inrush currents, EMI, harmonic and leakage currents will increase.

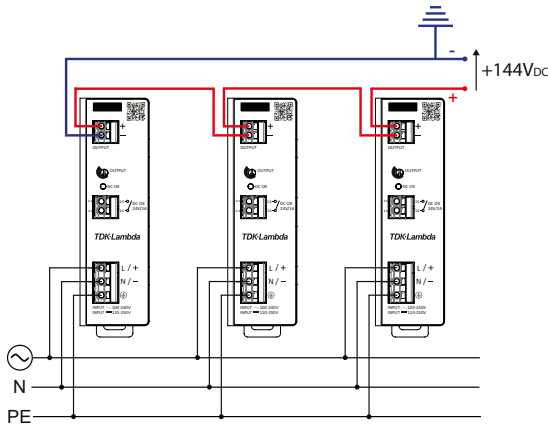

Fig. 25: Connection scheme for series operation with positive voltage level

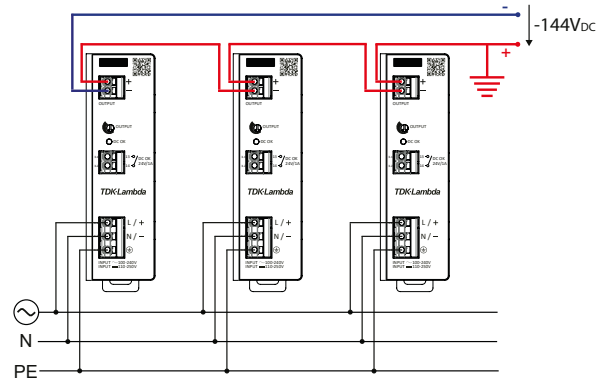

Fig. 26: Connection scheme for series operation with negative voltage level

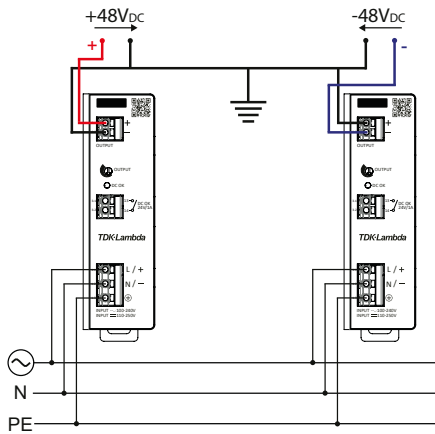

Fig. 27: Connection scheme for series operation with centre tap



TDK-Lambda France SAS

Tel: +33 1 60 12 71 65
tlf.fr-powersolutions@tdk.com
www.emea.lambda.tdk.com/fr



TDK-Lambda Americas

Tel: +1 800-LAMBDA-4 or 1-800-526-2324
tla.powersolutions@tdk.com
www.us.lambda.tdk.com



Italy Sales Office

Tel +39 02 61 29 38 63
tlf.it-powersolutions@tdk.com
www.emea.lambda.tdk.com/it



TDK Electronics do Brasil Ltda

Tel: +55 11 3289-9599
sales.br@tdk-electronics.tdk.com
www.tdk-electronics.tdk.com/en



Netherlands

tlf.nl-powersolutions@tdk.com
www.emea.lambda.tdk.com/nl



TDK-Lambda Corporation

Tel: +81-3-6778-1113
www.jp.lambda.tdk.com



TDK-Lambda Europe GmbH

Tel: +49 7841 666 0
tfg.powersolutions@tdk.com
www.emea.lambda.tdk.com/de



TDK-Lambda (China) Electronics Co. Ltd.

Tel: +86 21 6485-0777
tlc.powersolutions@tdk.com
www.lambda.tdk.com.cn



Austria Sales Office

Tel: +43 2256 655 84
tfg.at-powersolutions@tdk.com
www.emea.lambda.tdk.com/at



TDK-Lambda Singapore Pte Ltd.

Tel: +65 6251 7211
tfs.marketing@tdk.com
www.sg.lambda.tdk.com



Switzerland Sales Office

Tel: +41 44 850 53 53
tfg.ch-powersolutions@tdk.com
www.emea.lambda.tdk.com/ch



TDK India Private Limited, Power Supply Division

Tel: +91 80 4039-0660
mathew.philip@tdk.com
www.sg.lambda.tdk.com



TDK-Lambda Europe GmbH

Tel: Tel. +45 3222 8086
tfg.dk-powersolutions@tdk.com
www.emea.lambda.tdk.com/dk



TDK-Lambda UK Ltd.

Tel: +44 (0) 12 71 85 66 66
tlu.powersolutions@tdk.com
www.emea.lambda.tdk.com/uk



TDK-Lambda Ltd.

Tel: +9 723 902 4333
tli.powersolutions@tdk.com
www.emea.lambda.tdk.com/il-en

For further information please visit:
www.emea.lambda.tdk.com/d1se-series