

VT60 SPECIFICATIONS

PA728-01-01C

ITEMS	MODEL	VT60-522			VT60-5FF			VT60-525			
		V	A	W	%	-	mV	mV	mV	-	-
1	Nominal Output Voltage	V	5	+12	-12	5	+15	-15	5	+12	-5
2	Minimum Output Current	A	0.5	0	0	0.5	0	0	0.5	0	0
3	Maximum Output Current	A	5.0	2.0	0.5	5.0	1.6	0.5	5.0	2.0	0.5
4	Maximum Output Power	W	55			56.5			51.5		
5	Efficiency (Typ) (*1)	%	71			71			71		
6	Input Voltage Range (*2)	-	85-132VAC (47-440Hz) or 110-175VDC								
7	Input Current (Typ) (*1)	-	1.3A at 100VAC								
8	Inrush Current (Typ)	-	30A at 100VAC, Ta = 25°C								
9	Output Voltage Range	-	CH1 +5%, -0%, CH2, CH3 -FIXED								
10	Maximum Ripple & Noise (*3)	mV	120	150	150	120	150	150	120	150	120
11	Maximum Line Regulation (*3, 4)	mV	20	48	120	20	60	150	20	48	50
12	Maximum Load Regulation (*3, 5)	mV	40	96	120	40	120	150	40	96	50
13	Maximum Temperature Drift (*3, 6)	mV	50	120	240	50	150	300	50	120	100
14	Over Current Protection (*7)	-	105% ~								
15	Over Voltage Protection (*8)	-	Output shutdown 115% ~ 135% (CH1 Only)								
16	Hold-Up Time (Typ) (*1)	-	17ms at 50W								
17	Operating Temperature (*9)	-	-10 ~ 50°C : 100% 60°C : (70%)								
18	Operating Humidity	-	30 ~ 90% RH								
19	Storage Temperature	-	-30 ~ 85°C								
20	Storage Humidity	-	10 ~ 95% RH								
21	Cooling	-	Convection Cooled								
22	Withstand Voltage	-	Input - Output : 2kVAC, Input-FG : 2kVAC Output -FG : 500VAC 1 min.								
23	Isolation Resistance	-	More than 100MΩ at 25°C and 70%RH Output-FG 500VDC								
24	Vibration	-	10-55Hz (sweep 1 min) Less than 19.6m/s ² X,Y,Z 1h each								
25	Shock	-	Less than 196.1m/s ²								
26	Safety	-	Built to meet UL1950, CSA1402C & DENTORI								
27	Conducted Radio Noise	-	Built to meet VCCI-B & FCC class B								
28	Weight	-	280g								
29	Size (W.H.D)	mm	60 x 25 x 220								

NOTES :

- *1 : At 100VAC and Maximum Output Power, Ta = 25°C
- *2 : For cases where conformance to various safety specs (UL, CSA) are required to be described as 100-120VAC, 50/60Hz on name plate.
- *3 : Please refer to Fig. A for measurement determination of line & load regulation and output ripple voltage.
- *4 : From 85-132VAC, constant load.
- *5 : From Min load - Full load (Maximum power), constant input voltage.
- *6 : From -10 ~ +50°C, constant input voltage and load.
- *7 : Current limiting with automatic recovery.
Avoid to operate over load or dead short for more than 30 seconds.
- *8 : OVP circuit will shut down output, manual reset.
- *9 : At standard mounting method, Fig. B.

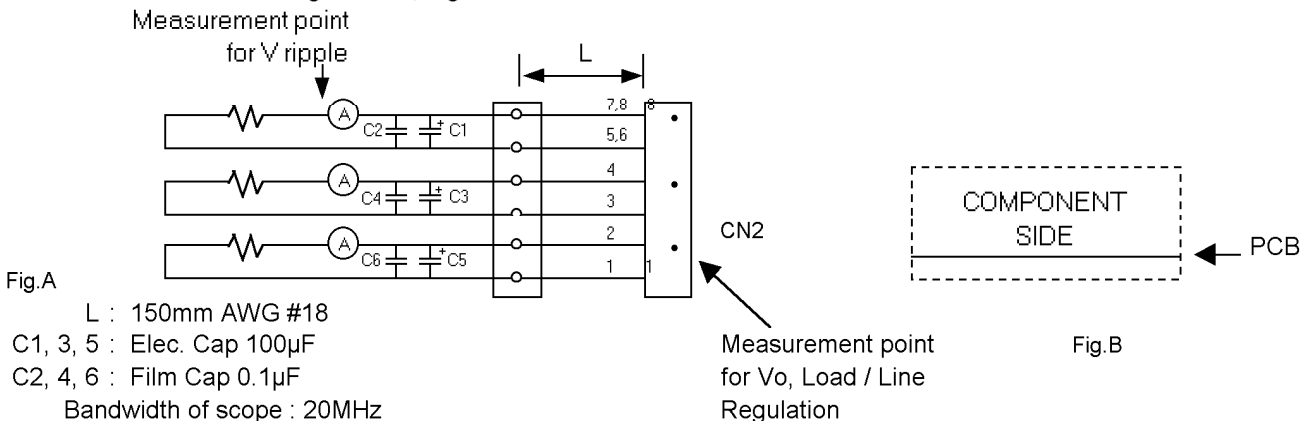

VT 6 0

OUTPUT DERATING

PA72B-01-02

* COOLING: CONVECTION COOLING

T _a (°C)	LOAD (%)				
	MOUNTING:A	MOUNTING:B	MOUNTING:C	MOUNTING:D	MOUNTING:E
-10	100	100	100	100	100
0	100	100	100	100	100
25	100	100	100	100	100
40	100	100	100	100	100
50	100	100	90	90	90
60	70	70	70	60	60

OUTPUT DERATING CURVE

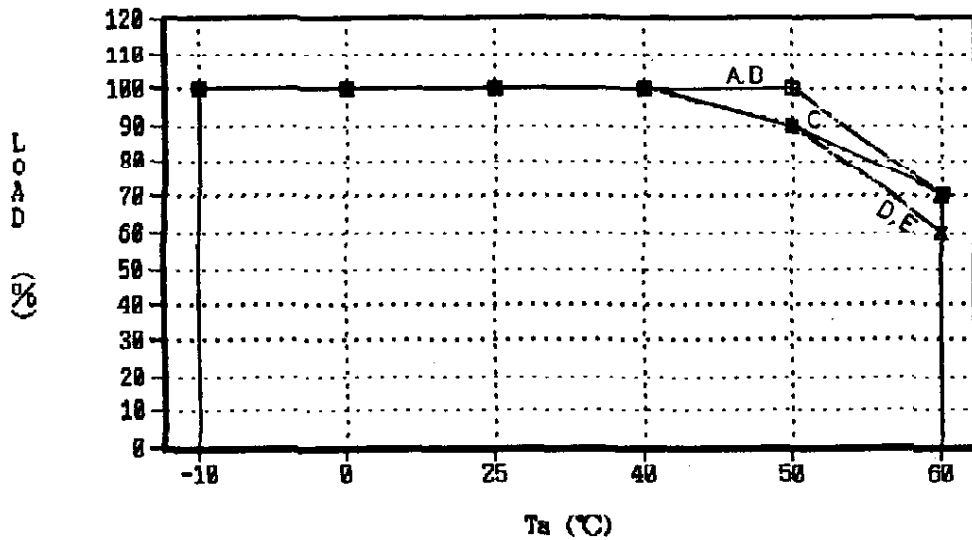

□ MOUNTING A + MOUNTING B ◇ MOUNTING C △ MOUNTING D × MOUNTING E

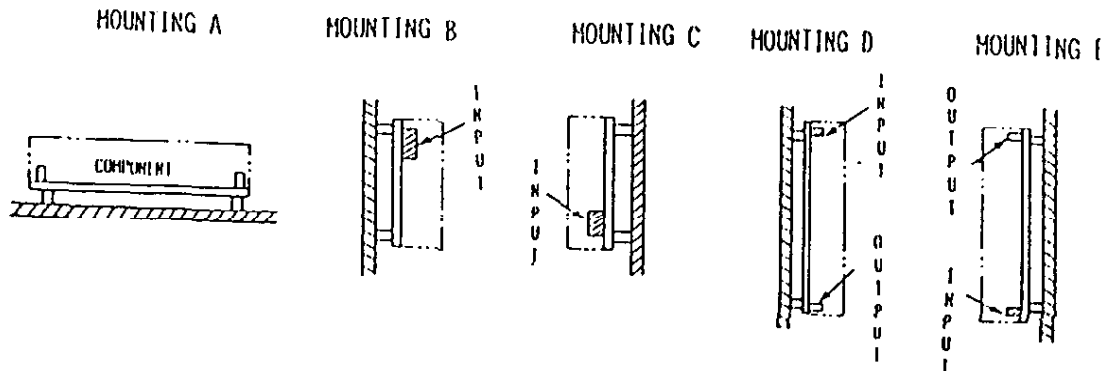

ANEMIC-LAMBDA