

PAQ65D48 - *

**TEST DATA
IEC61000 SERIES**

PA566-58-01

DENSEI-LAMBDA

INDEX

	PAGE
1. Electrostatic discharge immunity test ----- (IEC61000-4-2)	E-1 ~ 2
2. Radiated, radio-frequency, electromagnetic field immunity test ----- (IEC61000-4-3)	E-3 ~ 4
3. Electrical fast transient / burst immunity test ----- (IEC61000-4-4)	E-5 ~ 6
4. Surge immunity test ----- (IEC61000-4-5)	E-7 ~ 8
5. Conducted disturbances induced by radio-frequency field immunity test ---- (IEC61000-4-6)	E-9 ~ 10

* Test results are typical data. Nevertheless, the following results are considered to be actual capability data because all units have nearly the same characteristics.

1. Electrostatic discharge immunity test (IEC61000-4-2)

MODEL : PAQ65D48-5033

(1) Equipment Used

Electrostatic Discharge Simulator : ESS-630A (Noise Laboratory Co.,LTD.)
Discharge Resistance : 330Ω
Capacitor : 150pF

(2) The Number of D.U.T. (Device Under Test)

PAQ65D48-5033 : 1 unit

(3) Test Conditions

Input Voltage	: 48VDC	Output Voltage	: Rated
Output Current	: Each channel 50%	Polarity	: +,-
Number of Tests	: 10 times	Ambient Temperature	: 25°C
Discharge Interval	: >1 Second	Air Velocity	: 2m/s

(4) Test Method and Device Test Point

Contact Discharge : FG
Air Discharge : Input and Output Terminals

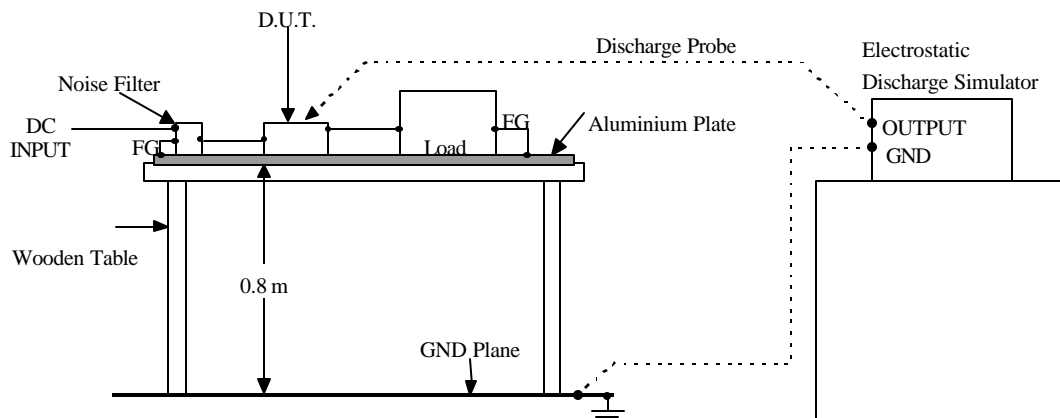

(5) Test Circuit

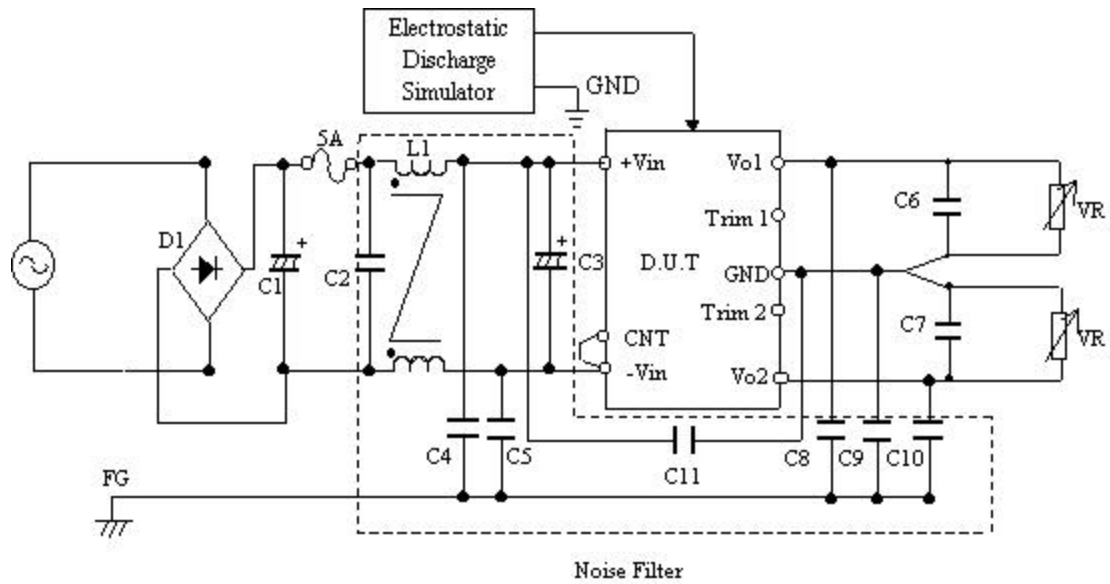

- Bridge Rectifier (D1) : PGH758A (NIHON INTER)
- Electrolytic Cap. (C1) : 400V, 8000µF
- Film Cap. (C2) : 100V, 1.5µF
- Electrolytic Cap. (C3) : 100V, 470µF
- Film Cap. (C4,C5) : 0.068µF
- Ceramic Cap (C6,C7) : 10V, 22µF
- Film Cap. (C8 to C10) : 0.033µF
- Ceramic Cap (C11) : 3kV, 4700pF
- Common-mode Choke Coil (L1) : 1mH

(6) Acceptable Conditions

1. Output voltage regulation not to be exceed $\pm 5\%$ of initial (before test) value during test.
2. Output voltage to be within regulation specification after the test.
3. No fire or smoke, as well as no output failure on the test.

(7) Test Results

Test Method	Test Voltage (kV)	PAQ65D48-5033
Contact Discharge	5	PASS
Air Discharge	10	PASS

2. Radiated, radio-frequency, electromagnetic field immunity test (IEC61000-4-3)

MODEL : PAQ65D48-5033

(1) Equipment Used

TS5010 Radiated Immunity Measurement System (TOYO CORPORATION)

Bilog Antenna

(2) The Number of D.U.T. (Device Under Test)

PAQ65D48-5033 : 1 unit

(3) Test Conditions

Input Voltage	: 48VDC	Output Voltage	: Rated
Output Current	: Each channel 50%	Amplitude Modulated	: 80%, 1kHz
Electromagnetic Frequency	: 80~1000MHz	Ambient Temperature	: 25°C
Distance	: 3m	Wave Angle	: Horizontal and Vertical
Sweep Conditions	: 1.0% Step up, 3 Seconds Hold		
Test Angle	: Top/Bottom, Both sides, Front/ Back		
Air Velocity	: 2m/s		

(4) Test Method

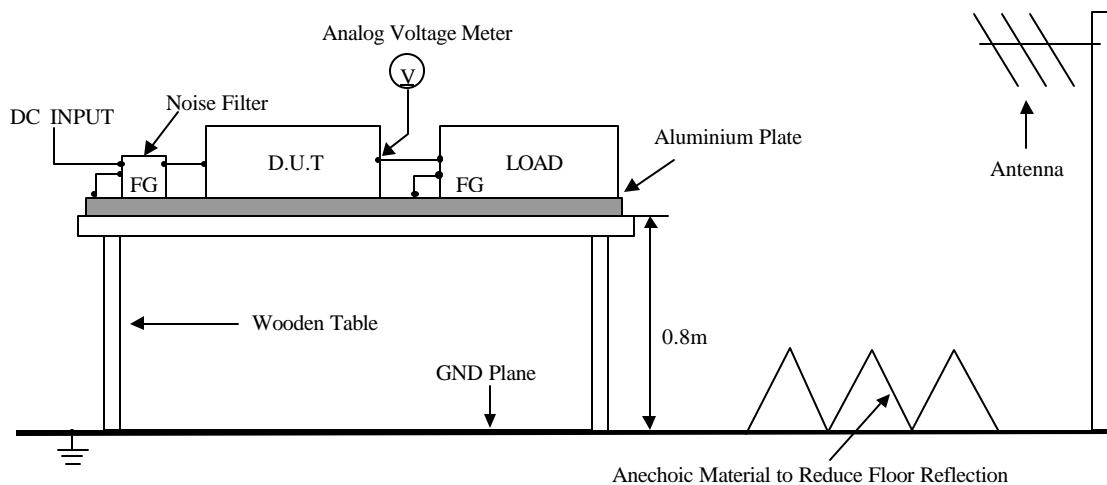

- Analog Voltage Meter is used because Oscilloscope may malfunction.

(5) Test Circuit

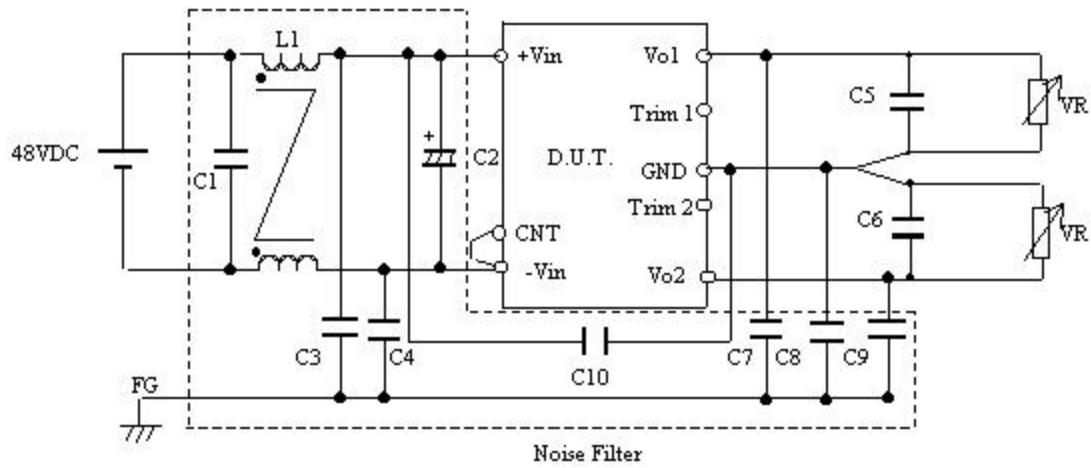

- Film Cap. (C1) : 100V, 1.5 μ F
- Electrolytic Cap. (C2) : 100V, 470 μ F
- Film Cap. (C3,C4) : 0.068 μ F
- Ceramic Cap (C5,C6) : 10V, 22 μ F
- Film Cap. (C7 to C9) : 0.033 μ F
- Ceramic Cap (C10) : 3kV, 4700pF
- Common-mode Choke Coil (L1) : 1mH

(6) Acceptable Conditions

1. Output voltage regulation not to be exceed $\pm 5\%$ of initial (before test) value during test.
2. Output voltage to be within regulation specification after the test.
3. No fire or smoke, as well as no output failure on the test.

(7) Test Results

Radiation Field Strength (V/m)	PAQ65D48-5033
1	PASS
3	PASS
10	PASS

3. Electrical fast transient / burst immunity test (IEC61000-4-4)

MODEL : PAQ65D48-5033

(1) Equipment Used

EFT/B (Generator) : NSG-2025 (SCHAFFNER Co.,LTD)

(2) The Number of D.U.T. (Device Under Test)

PAQ65D48-5033 : 1 unit

(3) Test Conditions

Input Voltage	: 48VDC	Output Voltage	: Rated
Output Current	: Each channel 50%	Polarity	: +, -
Number of Tests	: 3 times	Ambient Temperature	: 25°C
Test time	: 1 minute	Air Velocity	: 2m/s

(4) Test Method and Device Test Points

Apply to +, -, FG separately, as well as, all the same time.

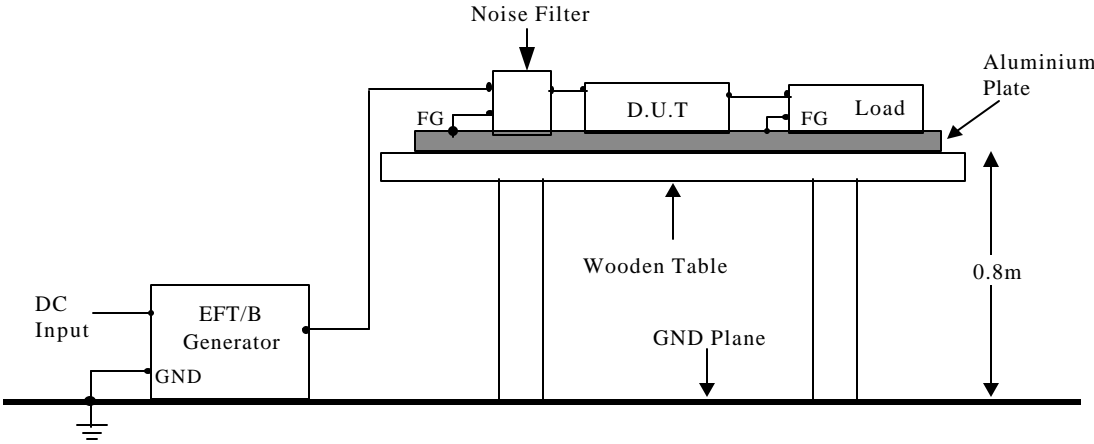

(5) Test Circuit

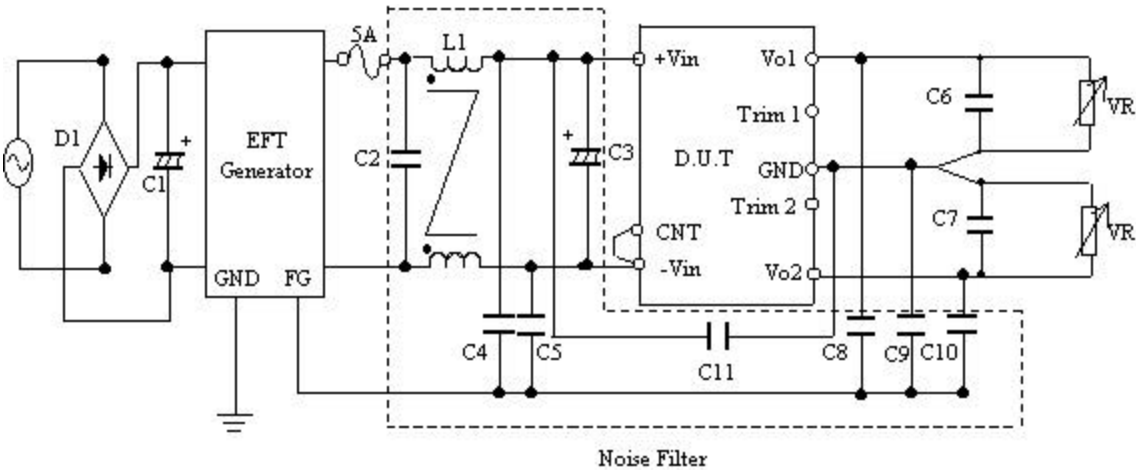

- Bridge Rectifier (D1) : PGH758A (NIHON INTER)
- Electrolytic Cap. (C1) : 400V, 8000 μ F
- Film Cap. (C2) : 100V, 1.5 μ F
- Electrolytic Cap. (C3) : 100V, 470 μ F
- Film Cap. (C4,C5) : 0.068 μ F
- Ceramic Cap (C6,C7) : 10V, 22 μ F
- Film Cap. (C8 to C10) : 0.033 μ F
- Ceramic Cap (C11) : 3kV, 4700pF
- Common-mode Choke Coil (L1) : 1mH

(6) Acceptable Conditions

1. Output voltage regulation not to be exceed $\pm 5\%$ of initial (before test) value during test.
2. Output voltage to be within regulation specification after the test.
3. No fire or smoke, as well as no output failure on the test.

(7) Test Results

Test Voltage (kV)	Repetition Rate (kHz)	PAQ65D48-5033
2.0	5.0	Pass
2.2	5.0	Pass
2.4	5.0	Pass

4. Surge immunity test (IEC61000-4-5)

MODEL : PAQ65D48-5033

(1) Equipment Used

Surge Simulator : NSG-651 (SCHAFFNER Co.,LTD)
Coupling Impedance : Common 12Ω
Normal 2Ω
Coupling Capacitance : Common 9μF
Normal 18μF

(2) The Number of D.U.T. (Device Under Test)

PAQ65D48-5033 : 1 unit

(3) Test Conditions

Input Voltage	: 48VDC	Output Voltage	: Rated
Output Current	: Each channel 50%	Polarity	: +, -
Number of Tests	: 5 times	Ambient Temperature	: 25°C
Mode	: Common ,Normal	Air Velocity	: 2m/s

(4) Test Method and Device Test Points

Apply to Common mode (N-FG, L-FG) and Normal mode (N-L).

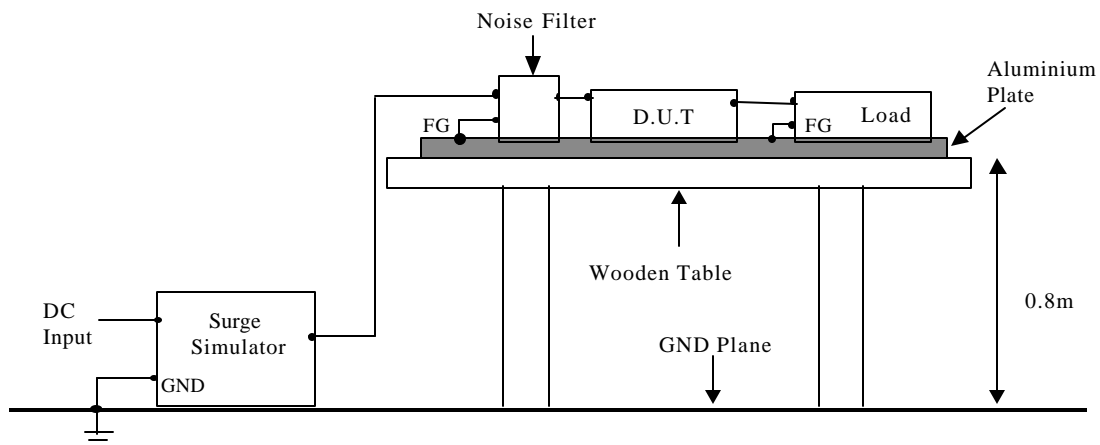

(5) Test Circuit

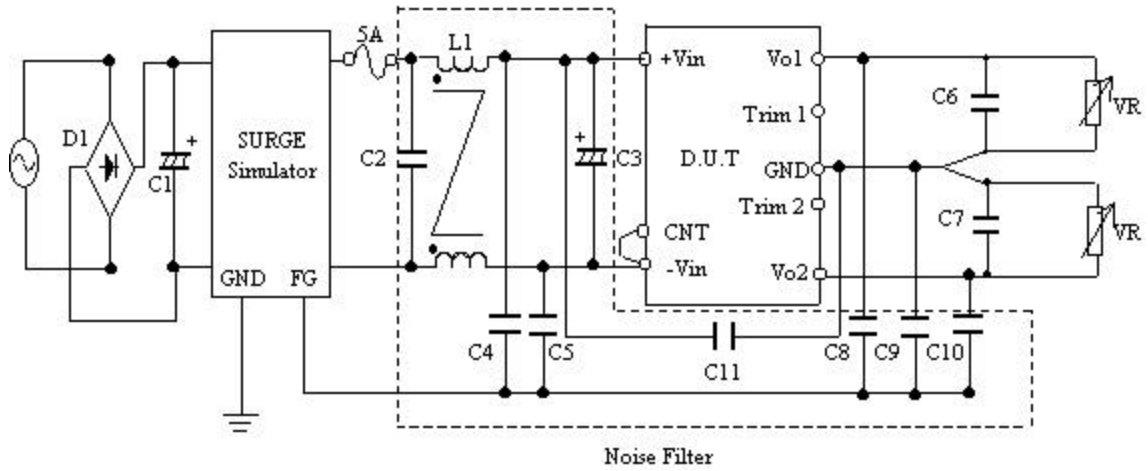

- Bridge Rectifier (D1) : PGH758A (NIHON INTER)
- Electrolytic Cap. (C1) : 400V, 8000 μ F
- Film Cap. (C2) : 100V, 1.5 μ F
- Electrolytic Cap. (C3) : 100V, 470 μ F
- Film Cap. (C4,C5) : 0.068 μ F
- Ceramic Cap (C6,C7) : 10V, 22 μ F
- Film Cap. (C8 to C10) : 0.033 μ F
- Ceramic Cap (C11) : 3kV, 4700pF
- Common-mode Choke Coil (L1) : 1mH

(6) Acceptable Conditions

1. Output voltage regulation not to be exceed $\pm 5\%$ of initial (before test) value during test.
2. Output voltage to be within regulation specification after the test.
3. No fire or smoke, as well as no output failure on the test.

(7) Test Results

Test Voltage (V)	PAQ65D48-5033	
	COMMON	NORMAL
200	PASS	PASS
300	PASS	PASS
400	PASS	PASS
500	PASS	PASS
600	PASS	PASS

5. Conducted disturbances induced by radio-frequency field immunity test (IEC61000-4-6)

MODEL : PAQ65D48-5033

(1) Equipment Used

RF Power Amplifier	:	A01580-50-R (R&K)
Signal Generator	:	SMG (ROHDE&SCHWARZ)
Coupling De-coupling Network (CDN)	:	KSI-8003 (KYORITSU)

(2) The Number of D.U.T. (Device Under Test)

PAQ65D48-5033 : 1 unit

(3) Test Conditions

Input Voltage	:	48VDC	Output Voltage	:	Rated
Output Current	:	Each channel 50%	Electromagnetic Frequency	:	150kHz~80MHz
Ambient Temperature	:	25°C	Air Velocity	:	2m/s
Sweep Conditions	:	1.0% Step up, 3.0 Seconds Hold			

(4) Test Method and Device Test Point

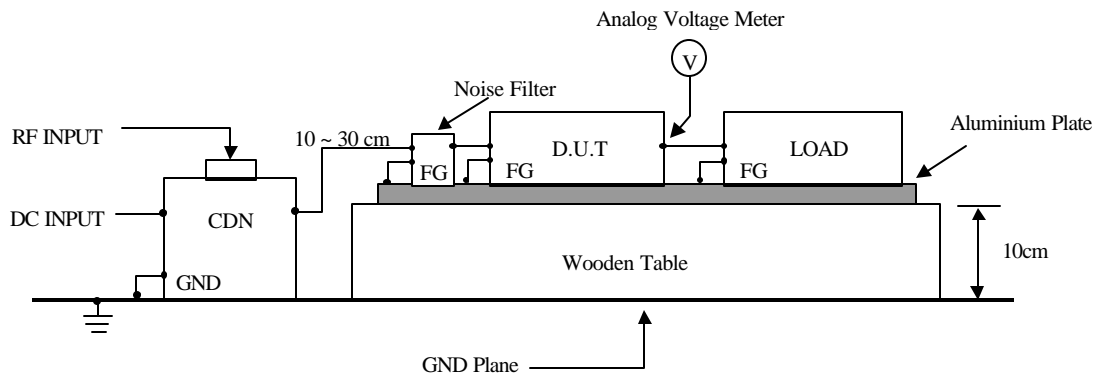

* Analog Voltage Meter is used because Oscilloscope may malfunction.

(5) Test Circuit

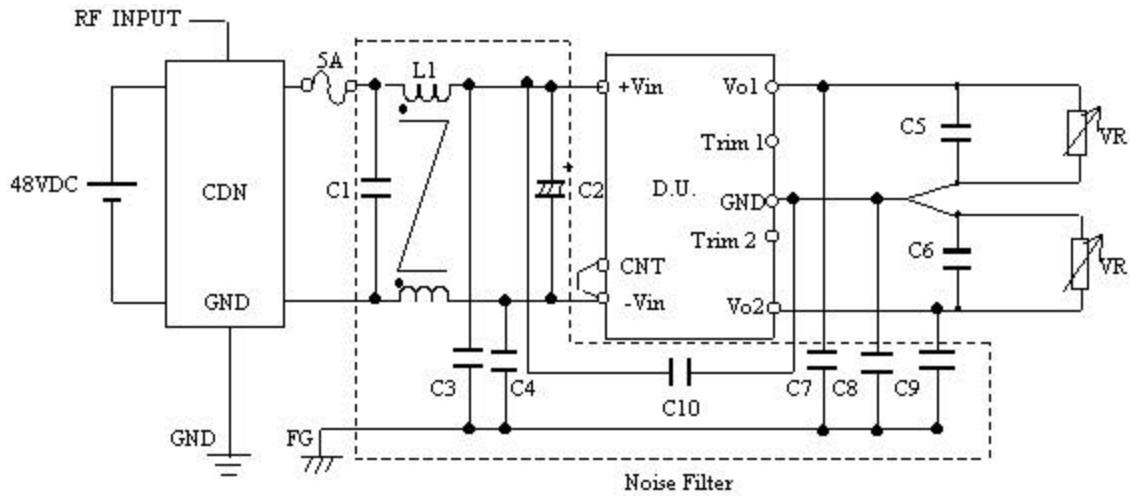

- Film Cap. (C1) : 100V, 1.5 μ F
- Electrolytic Cap. (C2) : 100V, 470 μ F
- Film Cap. (C3,C4) : 0.068 μ F
- Ceramic Cap. (C5,C6) : 10V, 22 μ F
- Film Cap. (C7 to C9) : 0.033 μ F
- Ceramic Cap. (C10) : 3kV, 4700pF
- Common-mode Choke Coil (L1) : 1mH

(6) Acceptable Conditions

1. Output voltage regulation not to be exceed $\pm 5\%$ of initial (before test) value during test.
2. Output voltage to be within regulation specification after the test.
3. No fire or smoke, as well as no output failure on the test.

(7) Test Results

Test Voltage (kV)	PAQ65D48-5033
1	PASS
3	PASS
10	PASS