

CPF1200F280-* Series

Instruction Manual

BEFORE USING THE POWER SUPPLY UNIT

Be sure to read this instruction manual thoroughly before using this product. Pay attention to all cautions and warnings before using this product. Incorrect usage could lead to an electrical shock, damage to the unit or a fire hazard.

DANGER

- Never use this product in locations where flammable gas or ignitable substances are present.

INSTALLATION WARNING

- When installing, ensure that work is done in accordance with the instruction manual. When installation is improper, there is risk of electric shock and fire.
- Installation shall be done by Service personnel with necessary and appropriate technical training and experience. There is a risk of electric shock and fire.
- Do not cover the product with cloth or paper etc. Do not place anything flammable around. This might cause damage, electric shock or fire.

WARNING on USE

- Do not touch this product or its internal components while circuit in operation, or shortly after shutdown. You may receive a burn.
- While this product is operating, keep your hands and face away from it as you may be injured by an unexpected situation.
- There are cases where high voltage charge remains inside the product. Therefore, do not touch even if they are not in operation as you might get injured due to high voltage and high temperature. You might also get electric shock or burn.
- Do not make unauthorized changes to this product nor remove the cover as you might get an electric shock or might damage the product. We will not be held responsible after the product has been modified, changed or disassembled.
- Do not use this product under unusual condition such as emission of smoke or abnormal smell and sound etc. Please stop using it immediately and shut off the product. It might lead to fire and electric shock. In such cases, please contact us. Do not attempt repair by yourself, as it is dangerous for the user.
- Do not operate and store these products in environments where condensation occurs due to moisture and humidity. It might lead fire and electric shock.
- Do not drop or apply shock to this product. It might cause failure. Do not operate these products mechanical stress is applied.

CAUTION on MOUNTING

- Confirm connections to input terminals, output terminals and signal terminals are correct as indicated in the instruction manual before switching on.
- Input voltage, Output current, Output power, Base-plate temperature, ambient temperature and ambient humidity should be kept within specifications, otherwise the product will be damaged or malfunctioned.
- Input line and output line, please use the wires as short and thick as possible.
- Do not use this product in special environment with strong electromagnetic field, corrosive gas or conductive substances and direct sunlight, or places where product is exposed to water or rain.
- Mount this product properly in accordance with the instruction manual, mounting direction and shall be properly be ventilated.
- Please shut down the input when connecting input and output of the product.
- When mounted in environments where there is conductive foreign matter, dust or liquid, there is possibility of product failure or malfunction. Such as install filter, please consider that a conductive foreign matter, dust and liquid do not invade inside the power supply.

 **CAUTION on USE**

- Product individual notes are shown in the instruction manual. If there is any difference with common notes, individual notes shall have priority.
- Before using this product, be sure to read the catalog and instruction manual. There is risk of electric shock or damage to the product or fire due to improper use.
- Input voltage, Output current, Output power, Base-plate temperature, ambient temperature and ambient humidity should be kept within specifications, otherwise the product will be damaged or malfunctioned, or cause electric shock or fire.
- For products without built-in protection circuit (element, fuse, etc.), insert fuse at the input to prevent smoke, fire during abnormal operation.
- For externally mounted fuse, do not use other fuses aside from our specified and recommended.
- As our product is standard industrial use product that was manufactured by purpose that is used to an general electronics equipment etc., it is not products that to designed for High Safety uses (Uses extremely high reliability and safety are required, if reliability and safety has not been secured, with significant dangerousness for directly life or body) is expected. Please consider a fail safe (systems that was provided with protection circuit protective devices or systems that redundant circuit was mounted so that was not unstable in single failure) design enough.
- When used in environments with strong electromagnetic field, there is possibility of product damage due to malfunction.
- When used in environment with corrosive gas (hydrogen sulfide, sulfur dioxide, etc.), there is possibility that they might penetrate the product and lead to failure.
- When used in environments where there is conductive foreign matter, dust or liquid, there is possibility of product failure or malfunction.
- Do not operate and store this product in an environment where condensation might occur. In such case, waterproof treatment is necessary.
- Provide countermeasure for prevention of lightning surge voltage as there is risk of damage due to abnormal voltage.
- Connect together the frame ground terminal of the product and the ground terminal of the equipment for safety and noise reduction. If these ground is not connected together, there is risk of electric shock.
- Take care not to apply external abnormal voltage to the output terminals and signal terminals. Especially, applying reverse voltage or overvoltage more than the rated voltage to the output might cause failure, electric shock or fire.
- Do not use this product in special environment with strong electromagnetic field, corrosive gas or conductive substances and direct sunlight, or places where product is exposed to water or rain.
- Never operate the product under overcurrent or short circuit condition. Insulation failure, or other damages may occur.
- On the occasion of obtain of Safety Standard, this power supply is not considered for connect between +Vin terminal and earth.
- The output of this product may, under fault conditions, exceed SELV voltage limits. Therefore the output must be protected in the end equipment to maintain SELV.
- The application circuits and their parameters are for reference only. Be sure to verify effectiveness of these circuits and their parameters before finalizing the circuit design. Moreover, we will not be responsible on application patent or utility model.

 **Note**

- Consider storage of the product at normal temperature and humidity avoiding direct exposure to sunlight at environment with minimal temperature and humidity changes. Storage of product at high temperature, high humidity and environments with severe changes in temperature and humidity might cause deterioration, and occurrence of condensation in the product.
- When disposing product, follow disposal laws of each municipality.
- The information in this document is subject to change without prior notice. Please refer to the latest version of the data sheet, etc., for the most up-to date specifications of the product.
- No part of this document may be copied or reproduced in any form without prior written consent TDK-Lambda.

1. Model name identification method

CPF 1200 F 280 – 14/□

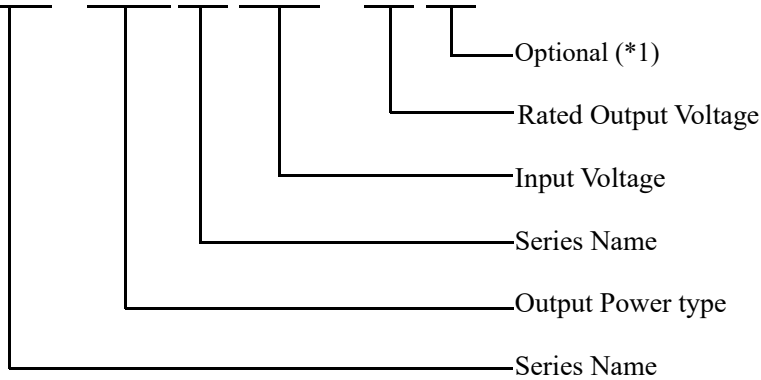

(*1) /Blank: Standard

/T: Mounting stand $\phi 3.3$
 (Non-threaded through hole)

/S: Short type terminal Pin
 (Length: 3.0mm)

/S*: Refer to the definition of the
 respective specifications

2. Terminal Explanation

[Input Side Terminals]

+Vin : +Input Terminal

-Vin : -Input Terminal

[Output Side Terminals]

+V : +Output Terminal

-V : -Output Terminal

+S : +Remote Sensing

-S : -Remote Sensing

TRIM : Output Voltage Trimming Terminal

PC : Output Current Balance Terminal

IOG : Inverter Operation Good

AUX : Auxiliary Power Supply for External Signals

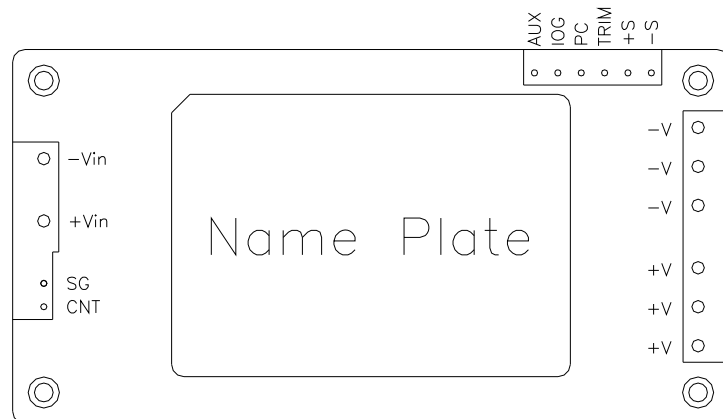

[Control Terminals]

CNT : ON/OFF Control terminal

SG : ON/OFF Control (ground side) terminal

Baseplate can be connected to FG through M3 mounting tapped holes.

Connect +Vin, -Vin, +V, -V with consideration of contacting resistance.

3. Block Diagram

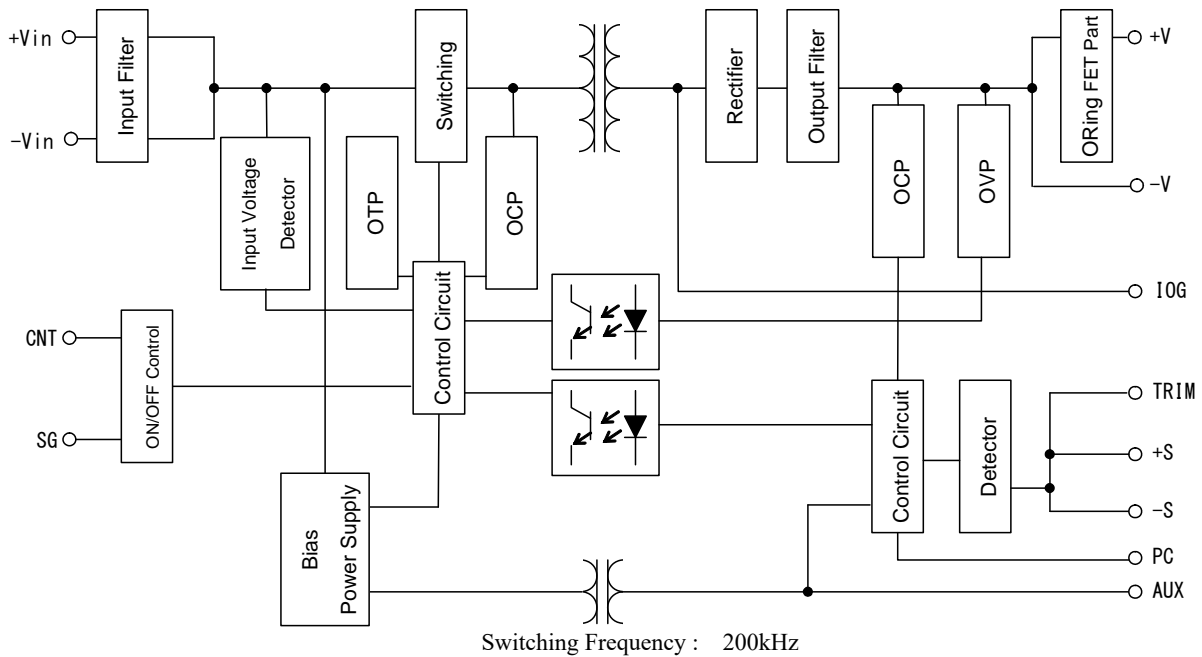

4. Sequence Time Chart

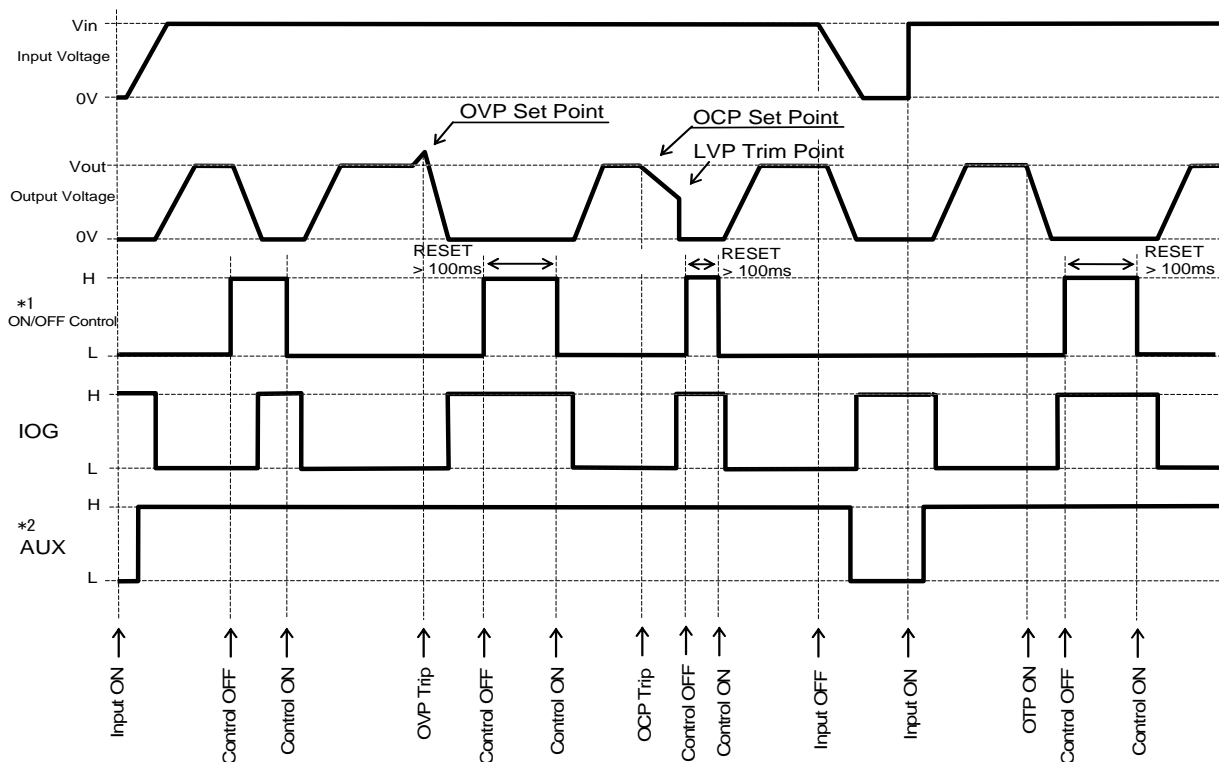

*1 Level : 4 ≡ H ≡ 35(V) or Open
 0 ≡ L ≡ 0.8(V) or Short

5. Terminal connecting method

In order to use the CPF1200F280 Series, this module must be connected with external components according to Fig.5-1.

Pay attention to each wiring. If it is connected to wrong terminal, the power supply will be damaged.

CPF1200F280 series employs conduction cooling method. Use heat sink and fan to dissipate heat. For selection of heat sink and heat sink dissipation method, refer to the Power Module Application Note.

External noise filter should be connected in order to meet EMI, EMS requirement. Refer to Evaluation data, Reliability data and IEC61000 Test data of CPF1200F280 series.

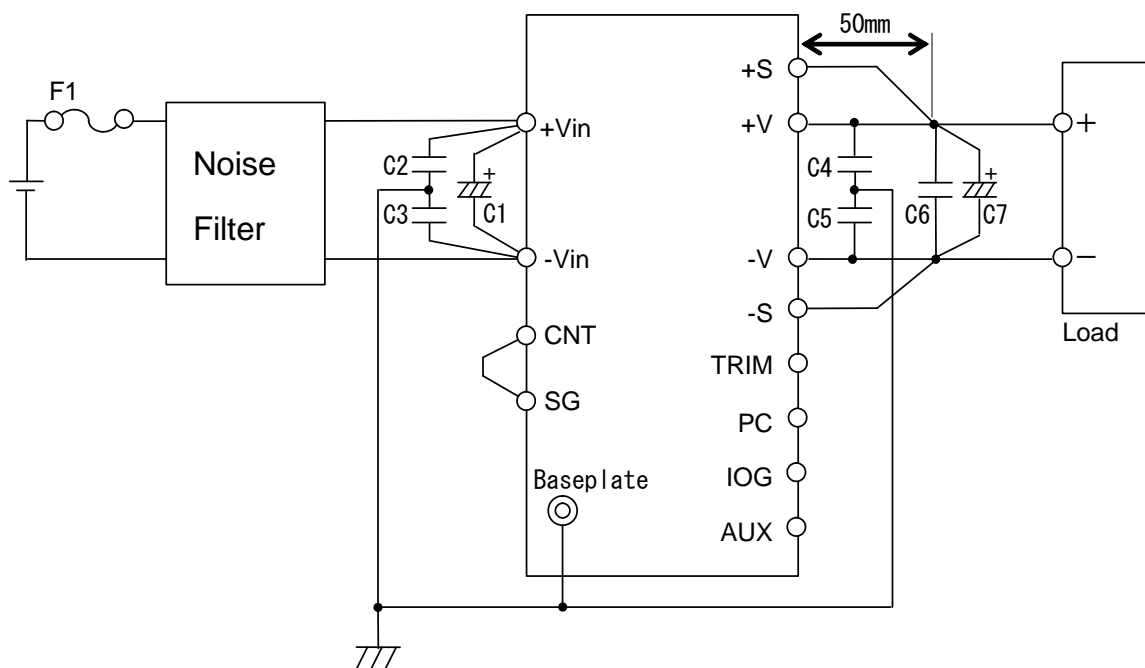

Fig.5-1 Basic connection

F1 : External Input Fuse

This CPF1200F280 Series has no built-in fuse.

Use external fuse to acquire various Safety Standards and to further improve safety.

Further, Fast-Blow type fuse must be used per one module. Also, in-rush surge current flows during line throw-in. Be sure to check I^2t rating of external switch and external fuse.

Furthermore, fuse must be connected to the +Vin side if -Vin side is used as ground, or fuse must be connected to -Vin side if +Vin side is used as a ground.

Recommended External Fuse: 10A or Lower

Note) Select fuse based on rated voltage, rated current and surge current capability.

C1 :

To prevent the effect of input line inductance to the power module, connect electrolytic capacitor or ceramic capacitor between +Vin and -Vin terminals.

Furthermore, use electrolytic capacitor with small ESR value. Especially take note that during line turn off at low ambient temperature, power module output will not normally shut down due to unstable C1 voltage.

Also, ripple current flows across this capacitor. Therefore, verify maximum allowable ripple current this capacitor when selecting component. Verify actual ripple current value by actual measurement.

Recommended capacitor value : 22 μ F and above (Voltage rating 450VDC)

- Note)
1. Use low impedance electrolytic capacitor with excellent temperature characteristics.
 2. When input line inductance becomes excessively high due to insertion of choke coil, operation of the power module could become unstable. For this case, increase C1 value more than the value indicated above.
 3. Use more than four recommended capacitors above in parallel when ambient temperature becomes lower than $-20\text{ }^{\circ}\text{C}$ to reduce ESR.

C2, C3 : 2200pF

To reduce spike noise voltage at the output, connect the high withstand voltage ceramic capacitor from +Vin terminal, -Vin terminal to the baseplate.

Withstand Voltage of C2, C3 : 3KVac and above

- Note)
1. Connect the C2 between +Vin terminal and baseplate, and the C3 between -Vin terminal and baseplate with the short connections as possible.
 2. There are cases where output ripple voltage could vary according to input wiring method or peripheral circuits. For this case, increase C2 and C3 value or connect common mode choke coil before C1.

C4, C5 : 0.022 μ F

To reduce spike noise voltage at the output, connect a ceramic capacitor.

Withstand voltage of C4,C5 : 500Vdc and above

Connect the C4 between +V terminal and baseplate, and the C5 between -V terminal and baseplate with the short connections as possible.

C6 : 2.2 μ F

To reduce spike noise voltage at the output, connect a ceramic capacitor between +V and -V within 50mm distance from the output terminals.

Also, take note that output spike noise voltage could vary according to PCB wiring design.

C7 : Refer to Table 5-1

For stable operation, connect an electrolytic capacitor between +V and -V at 50mm distance from the output terminals.

Take note that output ripple and output fall characteristics could be affected by electrolytic capacitor, equivalent impedance and inductance characteristics of wiring.

Take note that output ripple voltage could vary according to PCB wiring design.

For cases of abrupt changes in load current or input voltage, increasing capacitance value of the external capacitors could reduce the voltage fluctuation.

Table 5-1 C7: Recommended Values of External Output Capacitor

Vout	C7
14V	25V 1,500 μ F x 2 parallel

- Note) 1. Use low impedance electrolytic capacitor with excellent temperature characteristics. (Nippon Chemicon LXY Series or equivalent)
2. Use capacitors indicated in table 5-2 in parallel when ambient temperature becomes lower than -20°C because output ripple voltage could be affected by ESR.

Table 5-2 C7: Recommended Values of External Output Capacitor ($T_a < -20^{\circ}\text{C}$)

Vout	C7
14V	25V 1,500 μ F x 4 parallel

3. Take note of the allowable ripple current of the capacitor to be used. Especially, when load adding capacitors for abrupt current changes, be sure to verify that ripple current does not exceed allowable ripple current before use.

C8 :

When switches or connectors are used between input source and CPF1200F280-* Series input terminals, impulse surge voltage is generated at input due to input throw-in by switch on/off or due to inserting/removing of power module from the active line. For this case, connect an additional electrolytic capacitor C8 as shown in fig.5-2 and fig. 5-3.

Recommended Capacitance Value : 10~47 μ F and above (Voltage Rating 450VDC)

Also, in-rush current flows at line throw-in. Therefore, be sure to verify capability of switch or fuse to withstand I^2t at line throw-in.

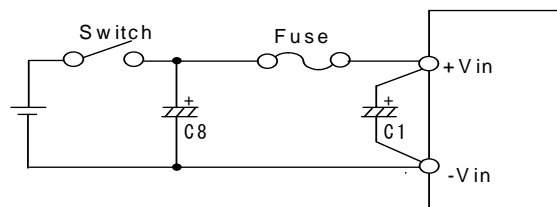

Fig.5-2 Input Filter with Input Switch

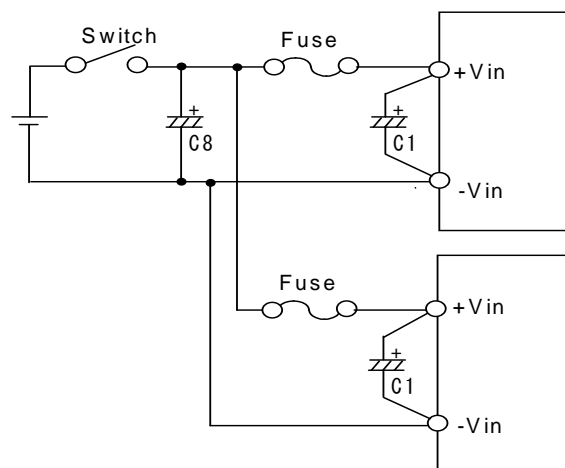

Fig.5-3 Input Filter when Plural Power

● **Reverse Input Connection**

Reverse input polarity would cause module damage. For cases where reverse connections are possible, connect a protective diode and fuse. Use protective diode with higher voltage rating than the input voltage, and with higher surge current rating than the fuse.

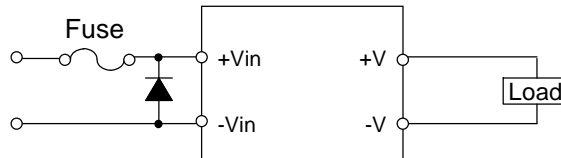

Fig.5-4 Protection for Reversed Connection of Input

6. Explanation of Functions and Precautions

6-1. Input Voltage Range

Input voltage range for CPF1200F280-* Series is indicated below.

Input Voltage Range : 200~400VDC

Basically, ripple voltage (V_{rpl}) which results from rectification and filtering of commercial AC line is included within the input voltage as shown in Fig. 6-1. Ripple voltage must be limited within the voltage described below.

Allowable input ripple voltage : 20Vp-p

When this value is exceeded, the output ripple voltage becomes large.

Note that sudden input voltage change may cause variation of output voltage transitionally.

Also, input voltage waveform peak value must not exceed above input voltage range.

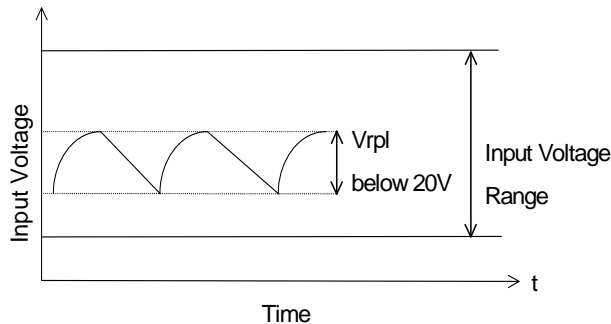

Fig.6-1 Ripple Voltage

6-2. Output Voltage Adjustment Range

Output voltage could be adjusted within the range described below by external resistor or variable resistor, or by applying external voltage. However, take note that OVP might trigger when output voltage adjustment exceeds the ranges indicated below.

Output Voltage Adjustment Range: 7.2V ~ 14V

Furthermore, when increasing the output voltage reduce the output current so as not to exceed the maximum output power.

Also, take note that when output voltage is increased, input voltage range is limited as shown in fig. 6-2.

With the external circuit as shown in fig.6-3, remote sensing is possible even when output voltage is varied. For details on remote sensing function, please refer to “**6-9. Remote Sensing**”

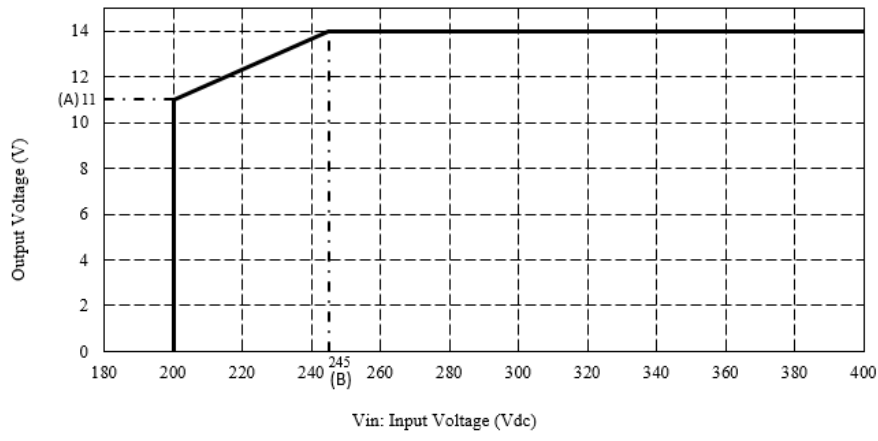

Fig.6-2 Limit of Input Voltage

Note: For curve inflection points A and B, the tolerances are $\pm 0.5V$ (A: $11 \pm 0.5V$) and $\pm 5V$ (B: $245 \pm 5V$) respectively.

● **Output Voltage Adjustment by External Resistor or Variable Resistor**

Resistor values, as well as, connecting methods for external resistor (Rex) and external variable resistor (VR) are described below.

In this case, using VR as remote programming resistor, remote programming of output voltage can be possible. Also, be sure to connect remote programming resistor between +S terminal and +V terminal.

Table6-1 Values of External Resistor and Variable Resistor:

	7.2V~14V Model
Rex	5.6kΩ
VR	20kΩ

External Resistor : below $\pm 5\%$ Tolerance

Variable Resistor : below $\pm 20\%$ Tolerance below 1% Remain

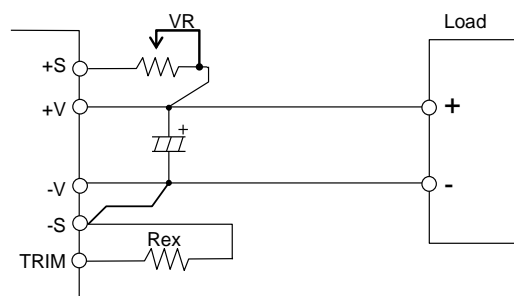

Fig.6-3 Example Connection of External Resistor

● **Output Voltage Adjustment by applying external voltage**

By applying external voltage at the TRIM terminal, output voltage can be adjusted within the same output voltage adjustment range as the output voltage adjustment by external resistor or variable resistor. For this case, output voltage can be determined by the formula shown below.

Output Voltage = TRIM Terminal Voltage × Nominal Output Voltage

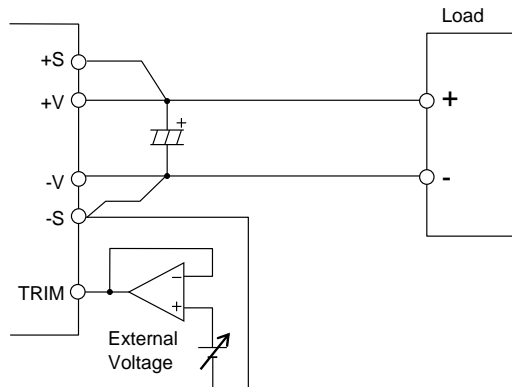

Fig.6-4 Output Voltage Adjustment by applying external voltage

For applications other than the above, refer to the trim circuit as shown in fig.6-5 and determine external circuit and component values.

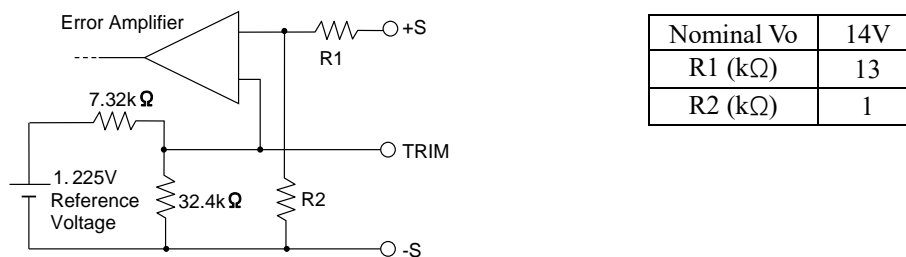

Fig.6-5 TRIM Circuit (For the Reference)

6-3. Maximum Output Ripple and Noise

Measured value according to the specified methods based on JEITA-9141 (Clause 7.12 and clause 7.13) which is described in the following.

Measure according to fig.6-6 connection, based on the basic connection of fig.5-1.

Connect capacitors (C6: ceramic capacitor 2.2μF, C7: refer to table 5-1 for electrolytic capacitor values) at 50mm distance from the output terminals. Measure at ceramic capacitor (C6) leads as shown in fig.6-6 using coaxial cable with JEITA attachment. Use oscilloscope with 100MHz frequency bandwidth or equivalent.

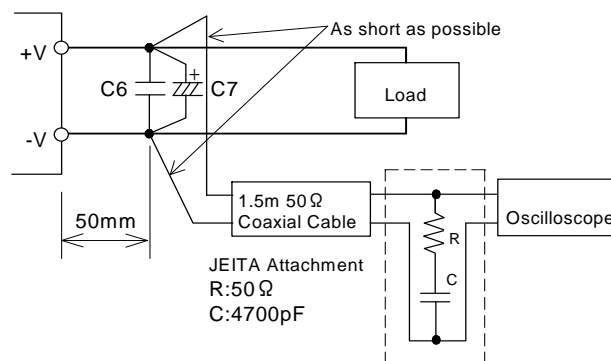

Fig.6-6 Measurement of Maximum Output Ripple & Noise

Take note that output ripple voltage and output spike noise may vary depending on PCB wiring design.

Generally, output ripple voltage and output spike noise can be reduced by increasing capacitance value of external capacitor.

6-4. Maximum Line Regulation

Maximum value of output voltage change when input voltage is gradually varied (steady state) within specified

input voltage range.

6-5. Maximum Load Regulation

Maximum value of output voltage change when output current is gradually varied (steady state) within specified output current range.

When using at dynamic load mode, audible noise could be heard from the power module and output voltage fluctuation might increase. A thorough pre-evaluation must be performed before using this power module.

6-6. Over Current Protection (OCP)

This power module has built-in OCP function.

This module is equipped with OCP function. Constant current limiting with delay shutdown for CPF1200F280 Series. Output will be shutdown when output about under 50% of rated output voltage by short circuit or overload condition that continue about 50ms. When the shutdown function activates, first cut off input line and verify that line voltage has dropped down to 0V. Then, recover output by recycling input line. In other method, reset to ON/OFF control.

OCP value is fixed and cannot be adjusted externally.

Note that continuous short circuit or overload condition, might result in power module damage.

6-7. Over Voltage Protection (OVP)

This power module has built-in OVP function.

OVP set point is relative to the rated output voltage value.

When OVP is triggered, output can be recovered by turning input line off and then turning it on again after input voltage drops down to 0V, or by manual reset of the control ON/OFF terminal. Reset time for ON/OFF terminal is 100ms or longer.

When verifying OVP function by applying external voltage at the TRIM terminal (refer to above Fig 6-4), applied voltage value should not exceed 2Vdc, the exceeded voltage will cause power module damage.

OVP setting value is fixed and cannot be adjusted externally.

6-8. Over Thermal Protection (OTP)

This power module has built-in OTP function. This function operates and shuts down the output when ambient temperature or internal temperature of power module abnormally rises. OTP operates at 105°C to 130°C baseplate temperature.

When OTP is triggered, output can be recovered by turning input line off and then turning it on again after input voltage drops down to 0V, or by manual reset of the control ON/OFF terminal, after temperature sufficiently decreased. Reset time for ON/OFF terminal is 100ms or longer.

6-9. Remote Sensing (+S, -S terminal)

Remote sensing terminal is provided to compensate for voltage drop across the wirings from the power supply output terminal to the load input terminal. Recommended capacitor value of C8 is same as C4.

When remote sensing function is not used (local sensing), short +S terminal to +V terminal and, -S terminal to -V terminal. When using remote sensing function, output power of power module should be within maximum output power. Also, use within maximum output adjustable voltage at output terminal. Moreover, take note that allowable maximum output current which can be used becomes less than the specification when output terminal voltage is set higher than rated voltage. (Allowable Maximum Output Current = Maximum Output Power's specification ÷ Output terminal Voltage)

When wire is long, Power Supply operation might be unstable due to noise. Moreover, please do enough prior evaluation for remote sensing function by using shielded wire, twist pair, or parallel pattern.

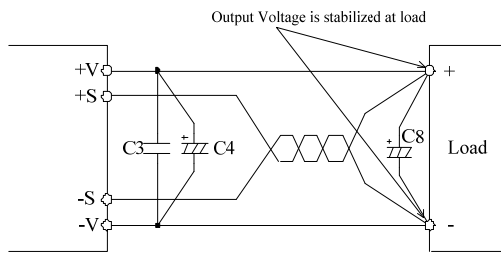

Fig.6-7 Remote Sensing at Use

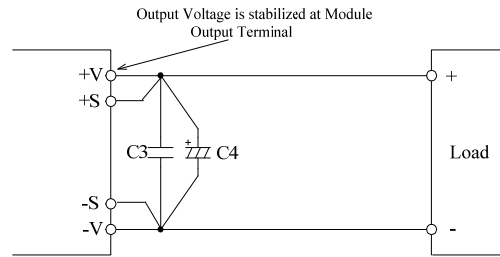

Fig.6-8 Remote Sensing Not in Use

6-10. ON/OFF Control (CNT, SG terminal)

Without turning the input supply on and off, the output can be enable and disabled using this function. ON/OFF control circuit is on the input side (the primary side), and CNT terminal pin is used. Use the SG terminal as ground for CNT terminal. If this function is not used, short the CNT terminal and the SG terminal.

- 1) The maximum impressed voltage for the CNT terminal is 35V and the maximum reverse voltage is 0.7V. Also the source current for CNT terminal is about 1mA.
 When wiring becomes long, connect a capacitor about 0.1μF value between the CNT and the SG terminal at a nearest distance.
- 2) ON/OFF terminal can be controlled by opening or closing connections (with switch or relay), or by photo-coupler ON/OFF.
 Also for the secondary control, isolation can be achieved through the use of a photo-coupler or equivalent.

* When using photo-coupler, connect between the CNT and the SG terminal to make transistor side shortest.

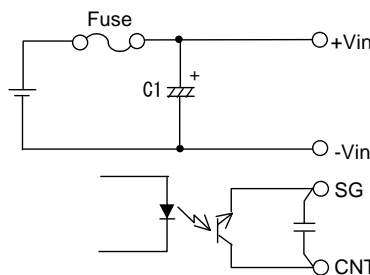

Fig.6-9 CNT, SG terminal connection

Table 6-3 ON/OFF Control Mode

CNT Level	Output Status
H (4V and above) or Open	OFF
L (0.8V and below) or short	ON

6-11. Parallel Operation (PC terminal)

By connecting the PC terminal of each power module, output current can be equally drawn from each module. A maximum of 11 units of the same model can be connected. Furthermore, be sure that the output power of every module does not exceed the maximum output power value. By setting output voltage accuracy of each module in a parallel operation to within ±1%, the maximum value of the output current that can be drawn is 95% of the total rated output current. Refer to “Parallel Operation” of the *Power Module Application Notes* for details.

6-12. Series Operation

Series operation is possible for CPF1200F280-* series. Connections shown fig. 6-10 and fig. 6-11 is possible

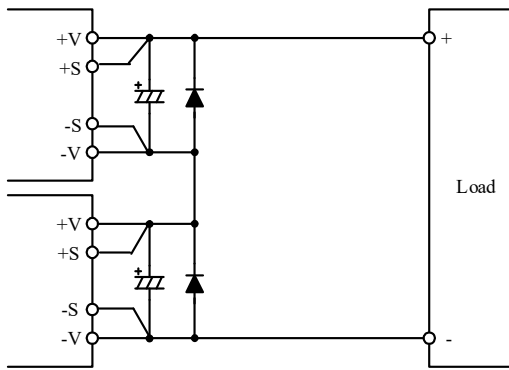

Fig.6-10 Series Operation in High Output Voltage

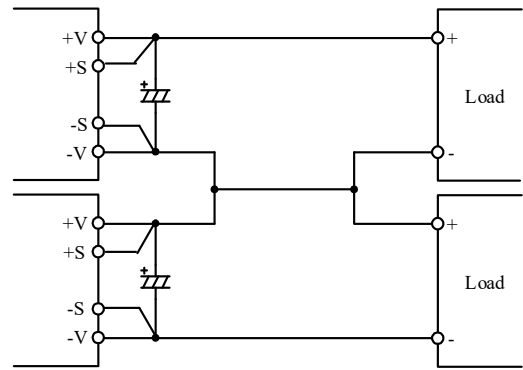

Fig.6-11 ±Output Series Operation

6-13. I.O.G. signal (IOG terminal)

Normal or abnormal operation of the power module can be monitored by using the IOG terminal. Output of this signal monitor is located at secondary side (output side) and is an open collector output.

This signal is LOW when inverter is normally operating and HIGH when inverter stops or when inverter is operating abnormally. (Maximum sink current is 5mA, maximum applied voltage is 35V)

Ground for the IOG terminal is the -S terminal.

Also note that IOG becomes unstable for following conditions:

- Operation of Over Current Protection (OCP)
- Light load conditions at parallel operation
- Dynamic load operation

6-14. Auxiliary power supply for external signals (AUX terminal)

For AUX terminal, output voltage value is within 10~14VDC range, maximum output current is 20mA. Ground for the AUX terminal is -S terminal.

Avoid short circuit of AUX terminal with other terminals as this would lead to power module damage.

6-15. OR-ing function

It has built-in OR-ing function for N+1 redundant application.

In case there is a unit failure in a parallel operating system, the OR-ing function will isolate the failure unit to ensure continuous power to the system.

6-16. Operating Ambient Temperature

There is no restriction on mounting direction but there should be enough consideration for airflow so that heat does not accumulate around the power module vicinity. Determine external components configuration and mounting direction on PCB such that air could flow through the heatsink at forced cooling and conventional cooling.

By maintaining actual baseplate temperature below 100°C, operation is possible.

For details on thermal design, refer to “Thermal Design” of the *Power Module Application Notes*.

Note) 1. Maximum baseplate temperature is 100°C. For worst case operating condition, verify baseplate temperature at measurement point indicated in fig. 6-12.

2. There is limitation on baseplate temperature range for as shown in fig.6-13.

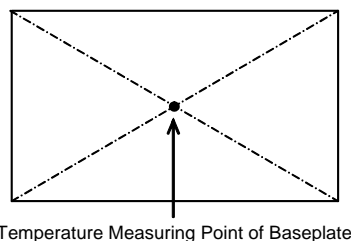

Fig.6-12 Temperature Measurement Point of Baseplate

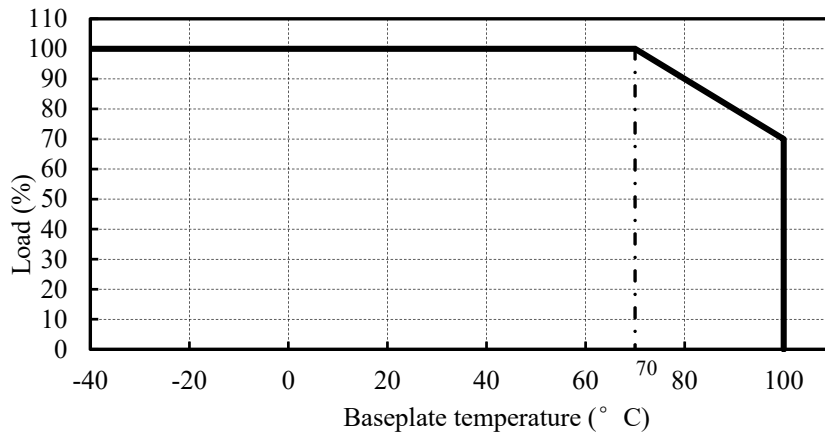

Fig.6-13 Derating curve

For better improvement of power module reliability, derating of baseplate temperature when using is recommended.

6-17. Operating Ambient Humidity

Take note that moisture could lead to power module abnormal operation or damage.

6-18. Storage Ambient Temperature

Abrupt temperature change would cause moisture formation that leads to poor solderability of each terminal of the power module.

6-19. Storage Ambient Humidity

Take enough care when storing the power module because rust which causes poor solderability would form in each terminal when stored in high temperature, high humidity environment.

6-20. Cooling Method

Operating temperature range is specified by the baseplate temperature. Therefore, several method of heat dissipation is possible.

For details on thermal design, refer to Application Notes “Thermal Design”.

6-21. Baseplate Temperature vs. Output Voltage Drift

Output voltage drift is defined as the rate of voltage change when baseplate temperature only is changed during operation.

6-22. Withstand Voltage

This power module is designed to have a withstand voltage of 2.5kVAC between input and baseplate, and 3kVAC between input and output for 1 minute.

When conducting withstand voltage test during incoming inspection, be sure to set the current limit value of the withstand voltage testing equipment to 20mA.

This power module is designed to have a withstand value of 500VDC between output and baseplate for 1 minute. When conducting withstand voltage test during incoming inspection, be sure to apply DC voltage.

Be sure to avoid conducting test with AC voltage because this would cause power module damage.

Furthermore, avoid throw in or shut off of the testing equipment when applying or when shutting down the test voltage. Instead, gradually increase or decrease the applied voltage. Take note especially not to use the timer of the test equipment because when the timer switches the applied voltage off, impulse voltage which has several times the magnitude of the applied voltage is generated causing damage to the power module.

Connect the terminals as shown in fig.6-14, fig.6-15 and fig.6-16.

When conducting test by the basic connection shown in fig.5-1, connect the terminals similarly.

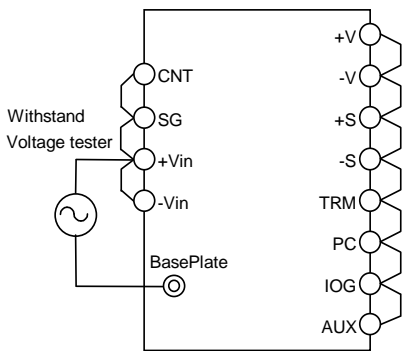

2.5kVAC 1minute (20mA)
Fig.6-14 Withstand Voltage Tester
for Input-Baseplate

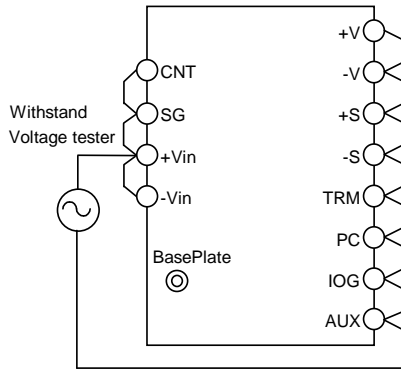

3kVAC 1minute (20mA)
Fig.6-15 Withstand Voltage Tester
for Input-Output

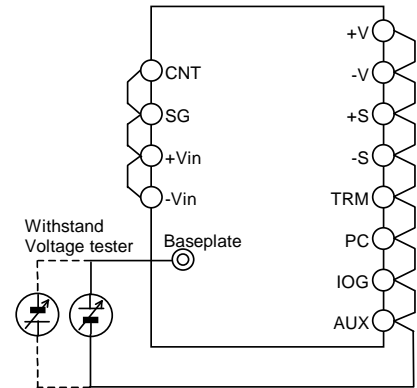

500VDC 1minute
Fig.6-16 Withstand Voltage Tester
for Output-Baseplate

Withstand Voltage Testing with External Application

The above Withstand Voltage Testing specification applies only to power supply as stand-alone unit. Please take note of the following points when Withstand Voltage Testing is performed with attached external application.

For applications that require external capacitor connections between input – base-plate and output – base-plate as shown in the Fig. 6-17, when testing withstand voltage between input – output, Voltage Divider Ratio between input – base-plate and output – base-plate will be affected by each total capacitance value ratio between the input – base-plate and output – base-plate.

When selecting each external capacitor, take care of the capacitance value and voltage rating.

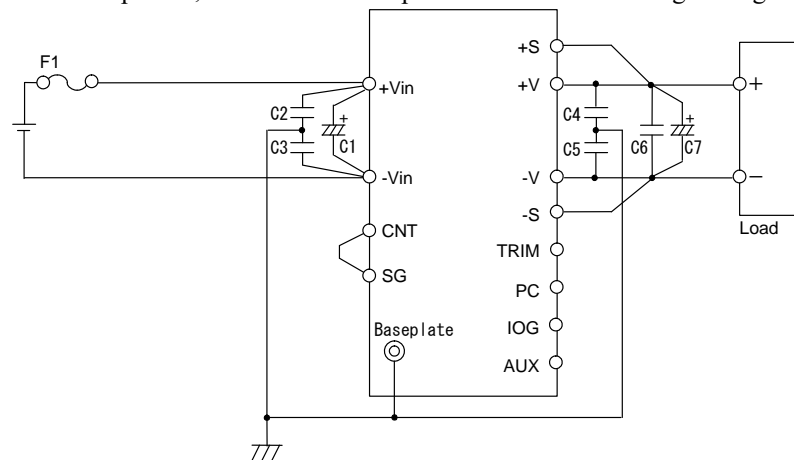
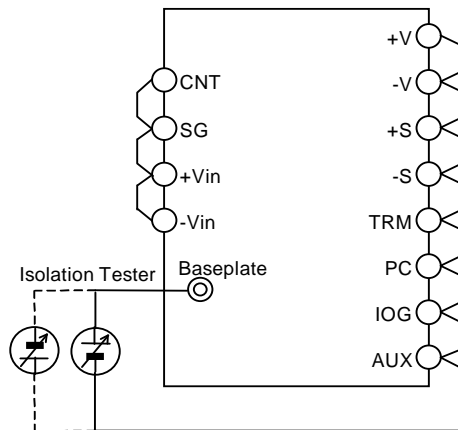

Fig.6-17 Example of connecting external application

6-23. Insulation Resistance

Use DC insulation tester (MAX 500V) between output and baseplate. Insulation resistance value is 100MΩ and above at 500VDC applied voltage. Also take note that depending on the insulation tester used, some testers generate high voltage pulse. Discharge the power module after test using a resistor, etc.



Over 100MΩ at 500VDC
Fig.6-18 Isolation Test

6-24. Withstand Vibration

Refer to Application Notes “Mounting Method” section.

6-25. Withstand Shock

Withstand shock value is defined to be the value at TDK-Lambda shipment and packaging conditions.

7. Mounting Method

7-1. Mounting Method

These products can be used in any orientation but be sure to consider enough airflow to avoid heat accumulation around the power supply. Consider surrounding components layout and set the PCB mounting direction such that air can flow through the heat sink by forced or convection cooling.

Refer to the power module application note “Power module mounting method” for mounting method on PWB.

(1) Method to Fixing on Printed Circuit Board

To fix a power module onto printed circuit board, use M3 screws and mount it to the M3 threaded holes of the power module. Recommended torque is 0.54N·m.

(2) Mounting Holes

Mounting holes of the power supply are connected to base-plate. Connect base-plate to FG (Frame Ground) by using these mounting holes.

(3) Mounting Holes on Printed Circuit Board

Refer to the following sizes when determining diameter of hole and land diameter of printed circuit board.

Terminals / Mounting Holes	Hole diameter	Land diameter
Signal terminals (φ1.0 mm)	φ1.5 mm	φ3.0 mm
Input / Output terminals (φ2.0 mm)	φ2.5 mm	φ5.0 mm
M3 Mounting Holes (FG)	φ3.5 mm	φ7.0 mm

For position of the holes, see outline drawing of the power supply.

(4) Recommended Material of PCB

A recommended material of the printed circuit board is double sided glass epoxy with through holes. (Thickness t: 1.6mm, copper 35μm)

(5) Input / Output Pattern Width

Large current flows through input and output pattern. If pattern width is too narrow, heat on pattern will

increase because of voltage drop of pattern. Relationship between allowable current and pattern width varies depending on materials of printed circuit board, thickness of conductor. It is definitely necessary to confirm on manufacturers of printed circuit board for designing pattern.

(6) Method of Connecting Terminals

Connect +Vin, -Vin, +V, -V with consideration of contacting resistance.

7-2. Heatsink Installation Method

(1) Method of Fixing Heatsink

To fix the heatsink onto power module, use M3 screws and mount it to the M3 threaded holes (4 places) at the base-plate side. Recommended torque is 0.54 N·m.

Use silicone grease or thermal conductive sheet in between heatsink and base-plate to minimize the contact thermal resistance and to enhance the heat conductivity.

Also use the no-warped heatsink and make sure good contact between base-plate and heatsink.

(2) Mounting Hole of Heatsink

Recommended mounting hole is as follows.

φ3.5 Non-threaded hole

7-3. Regarding Vibration

The vibration specification of the power supply is determined assuming that only the power supply is mounted on printed circuit board. To prevent excessive force to the power supply and the printed circuit board, fix the heatsink to the chassis as well as to the power supply when a large size of heatsink is used.

7-4. Recommended Soldering Condition

Recommended soldering conditions are as follows.

(1) Soldering dip

Dip condition : 260°C within 10 seconds

Pre-heat condition: 110°C for 30 - 40 seconds

(2) Soldering iron

350°C within 3 seconds

Note) Soldering time changes according to heat capacity of soldering iron, pattern on printed circuit board, etc. Please confirm actual performance.

7-5. Recommended Cleaning Condition

Recommended cleaning condition after soldering is as follows.

(1) Cleaning solvent

IPA (isopropyl alcohol)

(2) Cleaning Procedure

Use brush and dry the solvent completely.

8. Before Concluding Power Module Damage

Verify following items before concluding power module damage.

1) No output voltage

- Is specified input voltage applied?
- Are the ON/OFF control terminal (CNT, SG), remote sensing terminal (+S, -S), output voltage trimming terminal (TRIM) correctly connected?
- Is output current of the auxiliary power supply for external signals terminal (AUX) within the specified value?
- For cases where output voltage adjustment is used, is the resistor or variable resistor setting, connections correctly done?
- Are there no abnormalities in the output load used?
- Is the baseplate temperature within the specified temperature range?

2) Output voltage is high

- Are the remote sensing terminals (+S, -S) correctly connected?
- Is the measurement done at the sensing points?
- For cases where output voltage adjustment is used, is the resistor or volume setting, connections correctly done?

3) Output voltage is low

- Is specified input voltage applied?
- Are the remote sensing terminals (+S, -S) correctly connected?
- Is the measurement done at the sensing points?
- For cases where output voltage adjustment is used, is the resistor or variable resistor setting, connections correctly done?
- Are there no abnormalities in the output load used?

4) Load regulation and line regulation is large

- Is specified input voltage applied?
- Are the input terminals and the output terminals firmly connected?
- Is the measurement done at the sensing points?
- Is the input or output wire too thin?

5) Output ripple voltage is large

- Is the measuring method used the same or equivalent with the specified method in the Application Notes?
- Is the input ripple voltage value within the specified value?

9. Warranty Period

Warranty period is 5 years.

For damages occurring at normal operation within this warranty period, repair is free of charge.

Following cases are not covered by warranty

- (1) Improper usage like dropping products, applying shock and defects from operation exceeding specification of the unit.
- (2) Defects resulting from natural disaster (fire, flood etc.)
- (3) Unauthorized modifications or repair by the buyers' defects not cause by our company.