

PAH200H48 SERIES

Instruction Manual

■ Before Using This Power Module

Be sure to take note of precautions and warnings indicated in this manual when using this product. Improper usage may lead to electric shock or fire. Be sure to read this instruction manual thoroughly before using this product.

■ Caution

- There are high voltage and high temperature components within this product. Refrain from disassembling this product or touching its internal components as this may lead to electric shock or burned.
- When the unit is operating, keep your hands and face away from the unit. You may get injured by accident.
- Confirm connections to input/output terminals and signal terminals are correct as indicated in the instruction manual.
- Attach a fast blow type external fuse to each module to ensure safety operation and compliance to each safety standard approval.
- This power module is designed for professional installation within the end user equipment.
- Use isolated voltage by reinforced or double insulation as input power source.
- Do not inject abnormal voltage to output terminal and signal terminal from the outside.
The injection of reverse voltage or over voltage exceeding nominal output voltage to output terminals might cause Damage to internal output capacitor (Functional Polymerized Capacitor)
- The application circuits and their parameter are for reference only. Be sure to verify effectiveness of application circuits and their parameters before finalizing circuit design.
- The information in this document is subject to change without prior notice. For actual design-in, please refer to the latest publications of data sheet, etc., for the most up-to date specifications of the unit.
- No part of this document may be copied or reproduced in any for, or by any mean without prior written consent of Densei-Lambda.

■ Note : CE Marking

CE Marking, when applied to a product covered by instruction manual indicates compliance with the low voltage directive in that is complies with EN60950

DWG. No. : C170-04-02A		
APPD	CHK	DWG
<i>Yamamoto</i> 12. Jul. '12	<i>1030K01</i> 12. Jul. '12	<i>Matsumoto</i> 12. Jul. '12

Table of Contents

■ Block Diagram

■ Sequence Time Chart

■ Terminal Explanation

■ Explanation on Specifications

1. Input Voltage Range
2. Output Voltage Adjust Range
3. Maximum Output Ripple and Noise
4. Maximum Line Regulation
5. Maximum Load Regulation
6. Over Current Protection (OCP)
7. Over Voltage Protection (OVP)
8. Over Thermal Protection (OTP)
9. Remote Sensing (+S, -S terminal)
- 1 0. ON/OFF Control (CNT terminal)
- 1 1. Parallel Operation
- 1 2. Series Operation
- 1 3. Operating Ambient Temperature
- 1 4. Operating Ambient Humidity
- 1 5. Storage Ambient Temperature
- 1 6. Storage Ambient Humidity
- 1 7. Cooling Method
- 1 8. Temperature Coefficient
- 1 9. Withstand Voltage
- 2 0. Insulation Resistance
- 2 1. Vibration
- 2 2. Shock

■ Installation and Thermal Condition

1. Output Derating
2. Mounting PCB
3. Recommended Soldering Condition
4. Recommended Cleaning Condition

■ Before concluding power module damage

PAH200H48-SERIES

Block Diagram

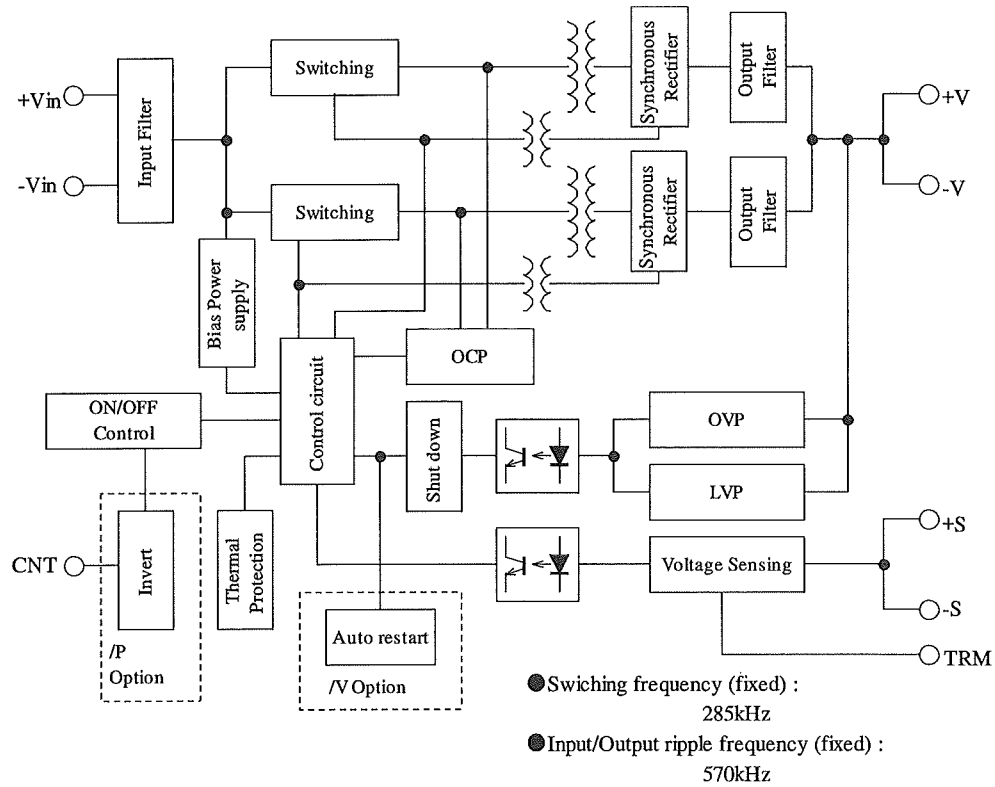

Sequence Time Chart

(for Standard Model with Latch type OVP and OCP, Negative logic for ON/OFF control)

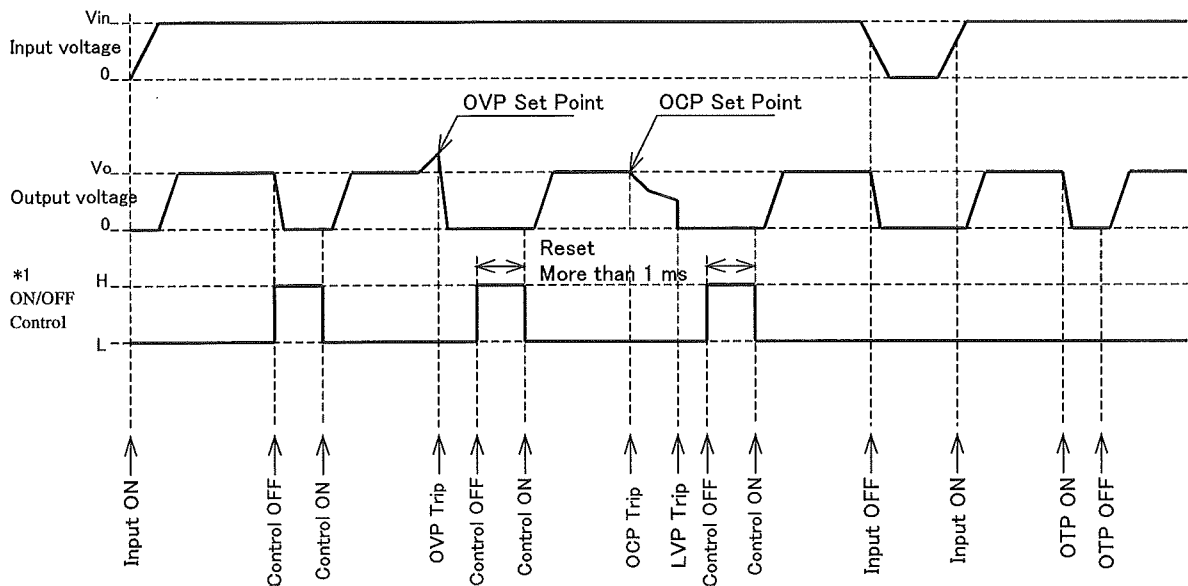

*1 level : $4 \leq H \leq 35(V)$ or Open
 $0 \leq L \leq 0.8(V)$ or Short

PAH200H48-SERIES

■ Terminal Explanation

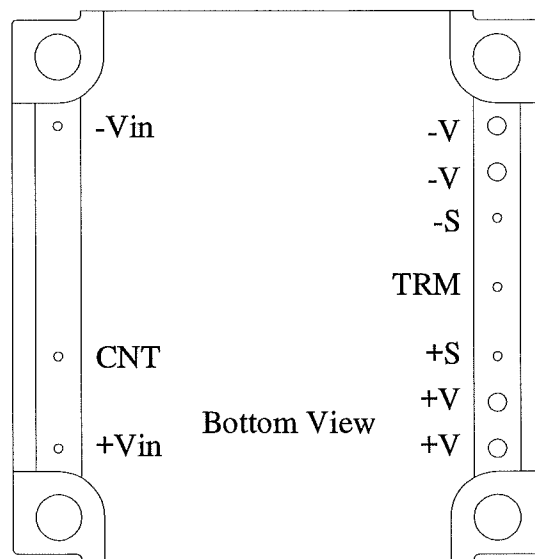

Input and Output Terminal Configurations (Bottom View)

[Input terminal]

-Vin : -Input Terminal
CNT : ON/OFF Control Terminal
+Vin : +Input Terminal

[Output terminal]

-V : -Output Terminal
-S : -Remote Sensing Terminal
TRM : Output Voltage Trimming Terminal
+S : +Remote Sensing Terminal
+V : +Output Terminal

Please ensure good connectivity to minimize the connection resistance for terminal +Vin, -Vin, +V and -V.

PAH200H48-SERIES

■ Explanation on Specifications

1. Input Voltage Range

Input voltage Range for PAH200H48 Series is indicated below.

Input Voltage Range : 36~76VDC
Maximum Applied Surge Voltage:
100VDC, 100ms

Basically, ripple voltage (V_{rpl}) which results from rectification and filtering of commercial AC line is included within the input voltage as shown in Fig.1-1. Ripple voltage must be limited within the voltage described below.

Allowable input ripple voltage : 4Vp-p

When this value is exceeded, the output ripple voltage becomes large. Note that abrupt input voltage change may cause the output voltage to fluctuate transitionally. Also, input voltage waveform peak value must not exceed above input voltage range.

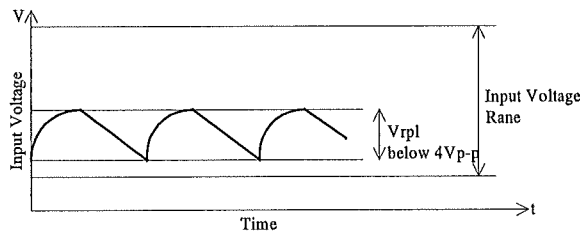

Fig.1-1 Input Ripple Voltage

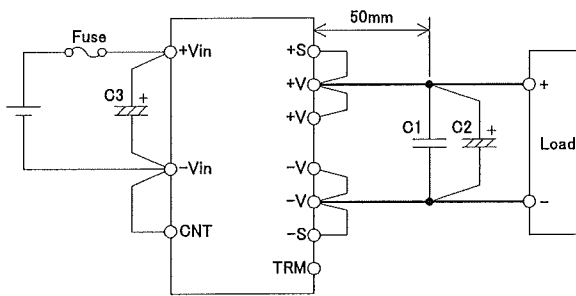

Fig.1-2 Basic Connection

(Standard Model : Negative Logic type for ON/OFF Control)

Input Fuse

PAH200H48 Series module is not internally fused. To ensure safe operation and to receive each Safety Standard approval, please connect an external fuse (fast-blow type) as shown in Fig.1-2

Fuse must be connected to the +Vin side if -Vin side is used as a ground, or fuse must be connected to -Vin side if +Vin side is used as a ground.

Recommended input fuse current rating:
PAH200H48: 10A

C1 : 1 μ F, C2 : 10 μ F

To reduce spike noise voltage at the output, connect 1 μ F ceramic capacitor and 10 μ F electrolytic capacitor or tantalum capacitor between +V and -V within 50mm distance from the output terminals.

Also, take note that output spike noise voltage could vary according to PCB wiring design.

Maximum capacitance of electrolytic capacitor that can be connected between +V and -V, is total 10,000 μ F.

C3:

Input capacitor C3 is recommended to stabilize to module when the module is powered from a high impedance source.

Select the electrolytic capacitor with low ESR and sufficient allowable ripple current.

Verify actual ripple current value by actual measurement.

Recommended capacitor value : 100 μ F and above
(voltage rating 100V or above)

Note)

1. Use low impedance electrolytic capacitor with excellent temperature characteristics. (Nippon Chemicon LXV Series or equivalent)

2. When input line inductance becomes excessively high due to insertion of choke coil operation of the power module could become unstable. For this case, increase C3 value more than the value indicated above.

3. When ambient temperature becomes lower than -20°C, connect two capacitors indicate above in parallel

C4:

When switches or connectors are used between input source and PAH200H48 Series input terminals, impulse surge voltage is generated due to input throw-in by switch on/off or due to inserting/removing of power module from the active line. For this case, connect an additional electrolytic capacitor C4 as shown in fig.1-3 and fig.1-4.

Recommended Capacitor : 100 μ F and above
(Voltage Rating 100V or above)

PAH200H48-SERIES

Also, in-rush current flows at line throw-in. Therefore, be sure to verify capability of switch or fuse to withstand I^2t at line throw-in.

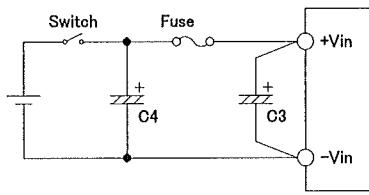

Fig.1-3 Input filter (C4) with Switch

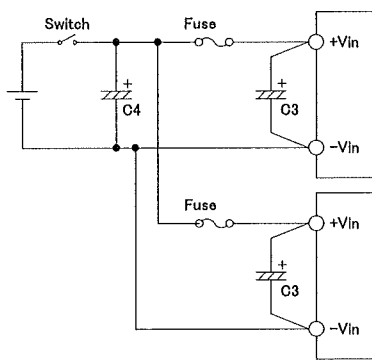

Fig.1-4 Input Filter with Switch when Plural Power

Reverse input connections

Reverse input polarity would cause module damage. For cases where reverse connections are possible, connect a protective diode and fuse. Use protective diode with higher voltage rating than the input voltage, and with higher surge current rating than the fuse.

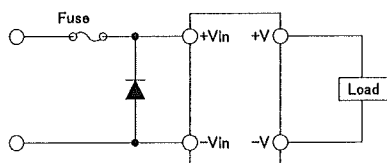

Fig.1-5 Protection for Reversed Input Connection

2. Output Voltage Adjustment Range

Output voltage could be adjusted within the range described below by external resistor or variable resistor. However, take note that OVP might trigger when output voltage adjustment exceeds the ranges indicated below.

Output Voltage Adjustment Range

3.3V : -15% ~ +15% of nominal output Voltage
 1.8V, 2.5V: -20% ~ +10% of nominal output Voltage

When increasing the output voltage reduce the output current accordingly so as not to exceed the maximum output power.

For 3.3V output model, take note that when output voltage is increased, input voltage range is limited as shown in fig.2-1.

Also, when output voltage is decreased under output adjustment range, output voltage will shut off.

Remote sensing is possible even when output voltage is varied. For details on remote sensing function, please refer to "9.Remote Sensing"

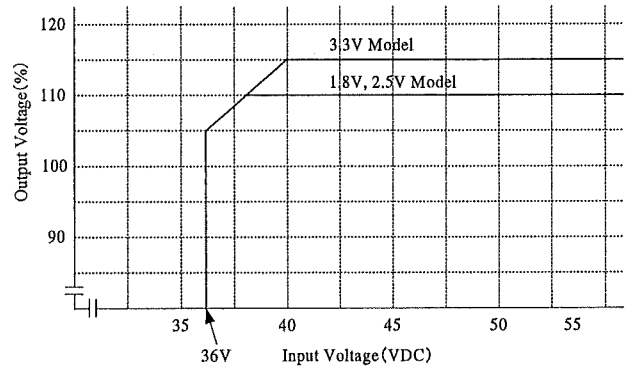

Fig.2-1 Limit of Input Voltage

Output Voltage Adjustment by external resistor or by variable resistor

- (1) In case of adjusting output voltage lower
 - (1-1) Available maximum output current = rated output current
 - (1-2) Connect an external resistor $R_{adj(down)}$ between the TRM terminal and $-S$ terminal.

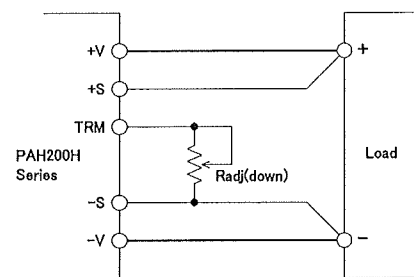

Fig.2-2 Connection for output voltage trim down (1)

- (1-3) Equation of external resistor and output voltage.

$$R_{adj(down)} = \left(\frac{100\%}{\Delta\%} - 2 \right) [k\Omega]$$

$R_{adj(down)}$: Value of external resistor
 $\Delta(\%)$: Output voltage change rate against nominal output voltage

PAH200H48-SERIES

Below graph is relation $\Delta\%$ and value of external resistor.

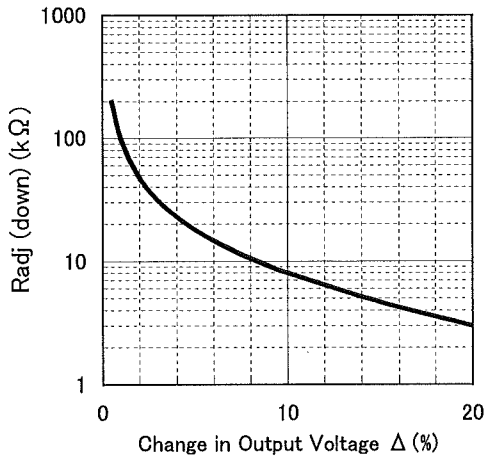

Fig.2-3 $\Delta(\%)$ vs. $R_{adj}(\text{down})$ (1)

- (2) In case of adjusting output voltage higher
 - (2-1) Allowable maximum output current = value of output power \div output voltage (reduce maximum output current in specification.)
 - (2-2) Connect an external resistor $R_{adj}(\text{up})$ between TRM terminal and +S terminal.

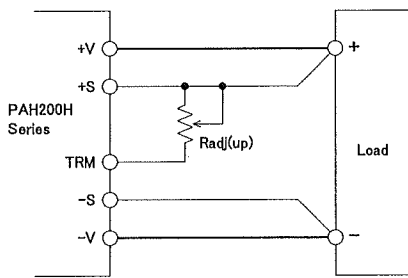

Fig.2-4 Connection for output voltage trim up(2)

(2-3) Equation of external resistor and output voltage

$$R_{adj}(\text{up}) = \left(\frac{V_o(100\% + \Delta\%)}{1.225 \times \Delta\%} - \frac{100\% - 2 \times \Delta\%}{\Delta\%} \right) [\text{k}\Omega]$$

V_o : nominal output value of module
 $R_{adj}(\text{up})$: external adjustment resistor
 $\Delta(\%)$: Output voltage change rate against nominal output voltage

Below graph is relation $\Delta(\%)$ and value of external resistor.

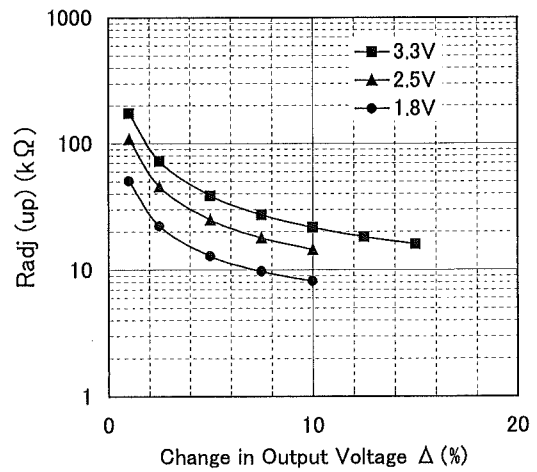

Fig.2-5 $\Delta\%$ vs. $R_{adj}(\text{up})$ (2)

- (3) To adjust output voltage for whole range Resistor values, as well as, connecting methods for external resistor (R1) and external variable resistor (VR) are described below.

	1.8V	2.5V	3.3V
R1	2.2k	1k	2.2k
VR	1k	2k	2k

unit: [Ω]

Table 2-3

Value of External Resistor and Variable Resistor

V_o	-20%, +10%	(1.8V, 2.5V)
V_o	$\pm 15\%$	(3.3V)

	1.8V	2.5V	3.3V
R1	5.6k	3.3k	5.6k
VR	500	1k	1k

unit: [Ω]

Table 2-4

Value of External Resistor and Variable Resistor ($\pm 10\%$ Variable)

R1 : $\pm 5\%$ Tolerance

VR : $\pm 20\%$ Tolerance

with end resistance below 1%

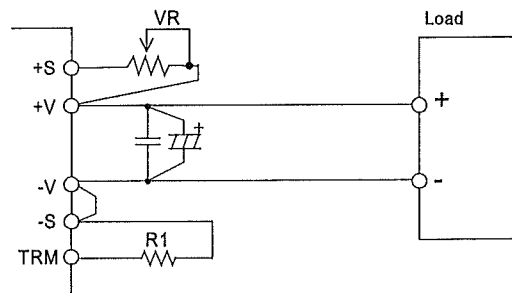

Fig.2-6 Example connection of external resistor

PAH200H48-SERIES

3. Maximum Ripple and Noise

(1) Measurement based on JEITA RC-9141

Measure according to the specified methods (Fig.3-1) based on JEITA RC-9141(Clause 7.12 and 7.13) which is described in the following. Connect capacitors (C1:ceramic capacitor 1μF, C2:tantalum capacitor 10μF) at 50mm distance from the output terminals. Measure at ceramic capacitor (C1) leads as shown in fig.3-1 using coaxial cable with JEITA attachment. Use oscilloscope with 100MHz frequency bandwidth or equivalent.

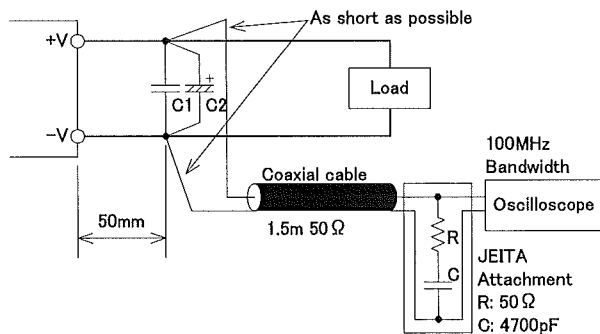

Fig.3-1

Measurement of Maximum Output Ripple & Noise Based on JEITA RC-9141

(2) Measurement using coaxial cable

Measure according to Fig.3-2. Connect capacitors (C1:ceramic capacitor 1μF, C2: tantalum capacitor 10μF) at 50mm distance from the output terminals. Measure at ceramic capacitor (C1) leads using coaxial cable. Use oscilloscope with 20MHz frequency bandwidth or equivalent.

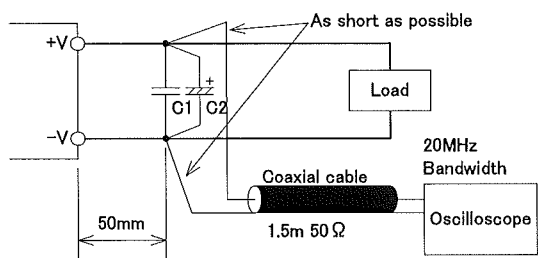

Fig.3-2

Measurement of Maximum Output Ripple & Noise Using coaxial cable

Take note that output ripple voltage and output spike noise may vary depending on PCB wiring design. Generally output ripple voltage and output spike noise can be reduced by increasing value of external capacitor.

4. Maximum Line Regulation

Maximum line regulation is the maximum value of output voltage change when input voltage is gradually varied within specified input voltage range. The measurement point for the input and output voltage are $\pm V_{in}$ and $\pm S$ (sense point) respectively.

5. Maximum Load Regulation

Maximum value of output voltage change when output current is gradually varied within specified output current range. The measurement point for the input and output voltage are $\pm V_{in}$ and $\pm S$ (sense point) respectively. When using at dynamic load mode, audible noise may be heard from the power module and output voltage fluctuation might increase.

6. Over Current Protection (OCP)

This power module has built-in OCP function. Output will recover when short circuit or overload conditions are released. OCP setting value is fixed and therefore, can not be externally adjusted. Also, take note, when output voltage drops down below lower side of adjustment range for 20ms~50ms by output short circuit or over load conditions, output might be shut down.

Output can be recovered by manual reset of the control ON/OFF terminal or by turning input line off and then turning it on again.

7. Over Voltage Protection (OVP)

This power module has built-in OVP function. OVP set point is relative to the rated output voltage value. When output voltage exceed OVP set point, output voltage shut down. OVP set point is fixed and therefore can not be changed. When OVP is triggered, output can be recovered by turning input line off and then turning it on again after lowering the input voltage below the voltage value indicated below or by manual reset of the control ON/OFF terminal.

Input voltage for OVP reset : 24VDC and below

/V Option (automatically recovery)

The /V optional model will re-start with delay of 100ms~400ms after shutdown by OCP or OVP triggering. When over voltage and over current are removed, output will recover normally.

Verifying OVP function shall be done by increasing output voltage with external resistor. For verifying OVP function, avoid applying external voltage to output terminal because this will cause power module damage.

PAH200H48-SERIES

8. Over Thermal Protection (OTP)

This power module has built-in OTP function. This function operates and shuts down the output when temperature of the power module rises abnormally. Take note that OTP will operate again unless the cause of abnormal heat of the power module is eliminated. For the details of OTP, refer to the clause of ("Mounting Method and Thermal Condition")

9. Remote Sensing (+S,-S Terminal)

Remote sensing terminal is provided to compensate for voltage drop across the wiring from the power module output terminal to the load input terminal.

When remote sensing function is not used (local sensing), short +S terminal to +V terminal and, -S terminal to -V terminal.

Fig.9-1 indicates connections when the remote sensing terminal is used. For optimum operations, connect electrolytic capacitor as large capacity as possible (within 10,000 μ F) between +V and -V terminal, as well as across the load terminals. Take note that voltage compensation range for line drop (voltage drop due to wiring) should be kept such that output voltage at the output terminals is within output voltage range and the maximum power is not exceeded. Use shielded wire, twist pair, or parallel pattern to reduce noise effect. When the remote sensing terminal is used, if the load wiring impedance is large, output power may disrupt the stability. To reduce the load wiring impedance, wiring should be thick and short as much as possible. When using the lead wiring, the wire should be twist pair, or when using the pattern, use the pattern layout as shown in fig.9-3 to reduce the impedance as small as possible.

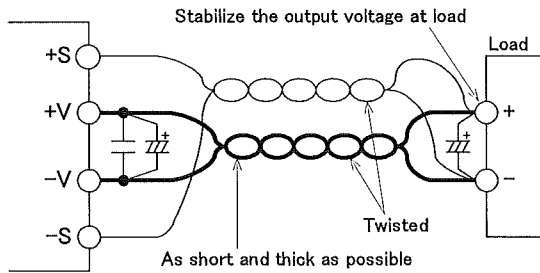

Fig.9-1 Remote Sensing in Use

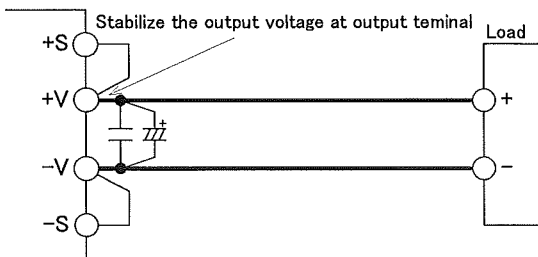

Fig.9-2 Remote Sensing Not in Use (Local Sensing)

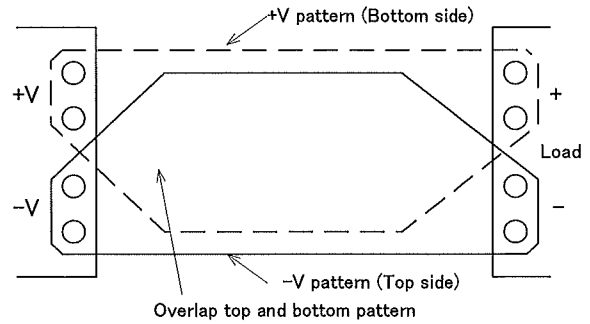

Fig.9-3 Example of Load Wiring Pattern Layout in using the double-sided PCB

10. ON/OFF Control (CNT Terminal)

Without turning the input supply on and off, the output can be enabled and disabled using this function. This function also can be used for output sequence of plural modules.

There are two kind of logic control, Negative logic control and Positive logic control, depend on the option selected.

ON/OFF control circuit is on the primary side (the input side), CNT Terminal pin. For secondary control, isolation can be achieved through the use of a opto coupler or relay.

	Logic	CNT Terminal Level to -Vin Terminal	Output status
Standard	Negative Logic	H Level ($4V \leq H \leq 35V$) or Open	OFF
[V option]		L Level ($0V \leq H \leq 0.8V$) or Short	ON
[P option]	Positive Logic	H Level ($4V \leq H \leq 35V$) or Open	ON
[PV option]		L Level ($0V \leq H \leq 0.8V$) or Short	OFF

*When control function is not used for the Standard, CNT terminal is shorted to -Vin terminal.

*When using long wiring, for prevention of noise, attach a 0.1 μ F capacitor between CNT Terminal and -Vin terminal.

*At L level, maximum source current from CNT terminal to -Vin terminal is 0.5mA

*The maximum CNT Terminal voltage is 35V.

(1) Output ON/OFF control

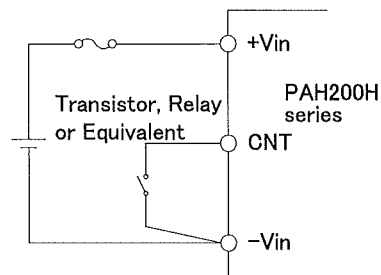

PAH200H48-SERIES

(2) Secondary (output side) control

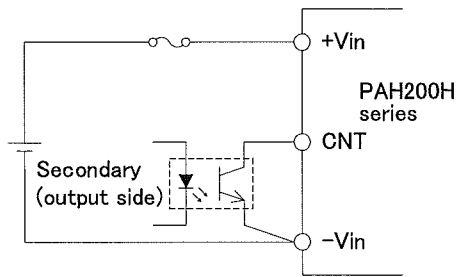

Fig.10-1 CNT Connection

11. Parallel Operation

Parallel Operation can not be used.

12. Series Operation

Series Operation is possible for PAH200H Series.

For the number of maximum series connection, Please contact us

(A) Series Operation in High Output Voltage

When Series Operation is used to obtain Higher Output Voltage, a bypass diode is needed to prevent the reverse voltage (refer Fig 12-1.) The selection guide for this bypass diode is described below :

Condition of selection, bypass diode D1,D2

1. Peak Repeated Reverse Voltage
 $VRRM \geq$ duplicate of nominal output voltage of the power supply.
2. Average output current
 $I_o \geq$ duplicate of nominal output current of the power supply.
3. Forward voltage
 $V_F \geq$ The lowest
 (schottky barrier diode and equivalent)

Output reverse maximum applied voltage : 0.6VDC and below

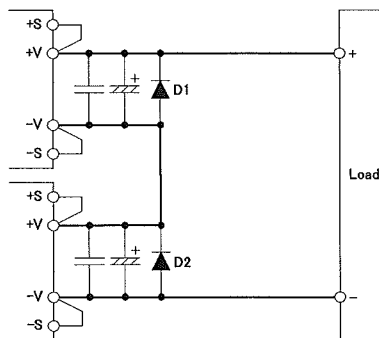

Fig.12-1 Series Operation for High Output Voltage

(B) \pm Output Series Operation

When +load and -load is completely separated the bypass diode is not required.

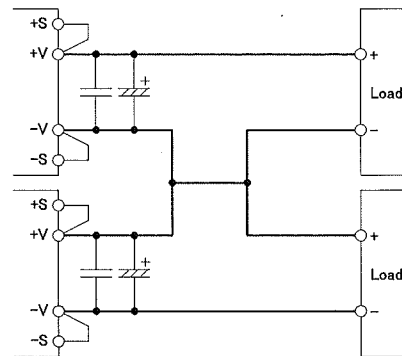

Fig.12-2 \pm Output Series Operation

13. Operating Ambient Temperature

According to ambient temperature, output load should derated accordingly (refer to Mounting Method & Terminal Condition). There is no restriction on mounting direction but there should be enough consideration for airflow so that heat does not accumulate around the power module vicinity.

Determine external components configuration and mounting direction on PCB such that air could flow through power module at forced air cooling or convection cooling. For better reliability, derating of ambient temperature is recommended. For details on derating, refer to "Mounting Method & Thermal Condition".

14. Operatin Ambient Humidity

Take note that moisture could lead to power module abnormal operation or damage.

15. Storage Ambient Temperature

Abrupt temperature change would cause condensation built-up that leads to poor solderability of terminals of the power supply.

16. Storage Ambient Humidity

High temperature and humidity can cause the terminals on the module to oxidize. The quality of the solder will become worse.

17. Cooling Method

Forced air cooling is recommended. Convection cooling is also possible. For the details of derating, refer to "Mounting Method and Thermal condition"

PAH200H48-SERIES

18. Ambient Temperature vs. Output Voltage Drift

Temperature coefficient is defined as the rate of voltage change when ambient temperature is changed during operation.

19. Withstand Voltage

This power module is designed to have a withstand voltage of 1.5kVDC between input to output. When conducting withstand voltage test during incoming inspection, be sure to apply DC voltage. Also, set the current limit value of the withstand voltage testing equipment to 10mA. Be sure to avoid conducting test with AC voltage because this would cause power module damage. Furthermore, avoid throw in or shut off of the testing equipment when applying or when shutting down the test voltage. Instead, gradually increase or decrease the applied voltage. Take note especially not to use the timer of the test equipment because when the timer switches the applied voltage off, impulse voltage which has several times the magnitude of the applied voltage is generated causing damage to the power module.

Short the output side as shown in fig.19-1.

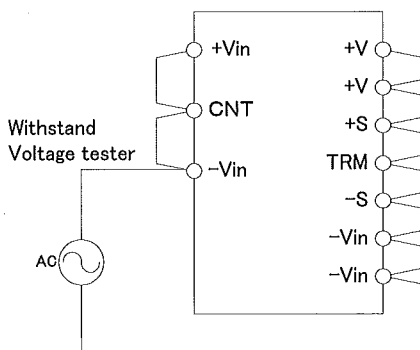

1.5kVDC 1minute (10mA)

Fig.19-1 Withstand Voltage Test for Input-Output

20. Insulation Resistance

Use DC insulation tester (MAX 500V) between output and input. Insulation resistance value is 100M Ω and above at 500VDC applied voltage. Make sure that during testing, the isolation testers does not produce a high pulse when the applied voltage is varied. Ensure that the tester is fully discharged after the test.

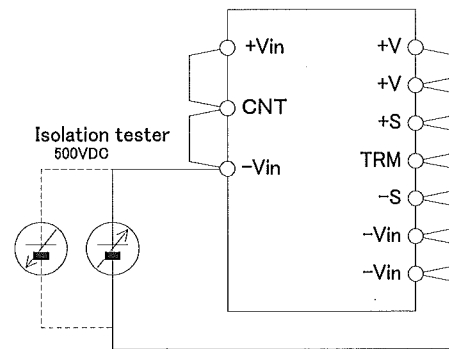

100M Ω and above at 500VDC

Fig.20-1 Isolated test

21. Vibration

Vibration of power module is defined in case of mounting on PCB.

22. Shock

Value for the conditions of out shipping and packing.

PAH200H48-SERIES

Mounting Method and Thermal Condition

1. Output derating

(1) Output Derating by ambient temperature

There is no restriction on mounting direction but there should be enough consideration for airflow so that heat does not accumulate around the power module vicinity. Determine external components configuration and mounting direction on PCB such that air could flow through power module at forced air cooling or convection cooling. Take note, output power derating is needed as shown in followings. The derating curves provided is based on the below set-up condition.

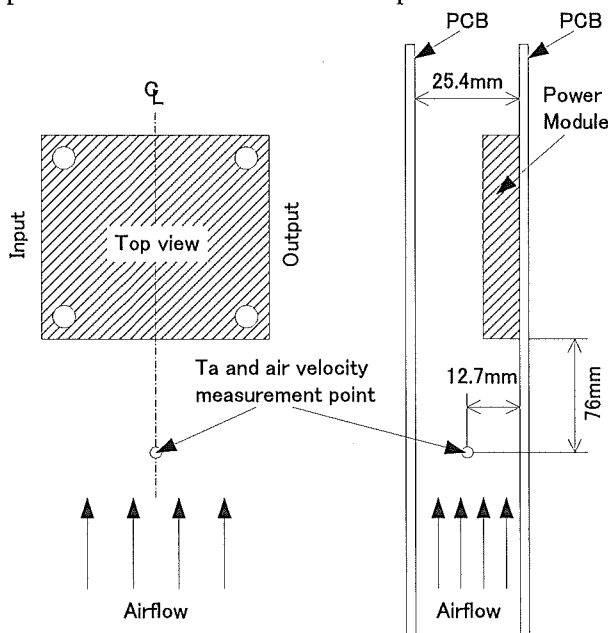

Fig.1-1 Output derating set-up condition

Output derating by ambient temperature

$V_{in}=48VDC$ at standard vertical mounting

PAH200H48-1R8 (include /P, /V, /PV option)

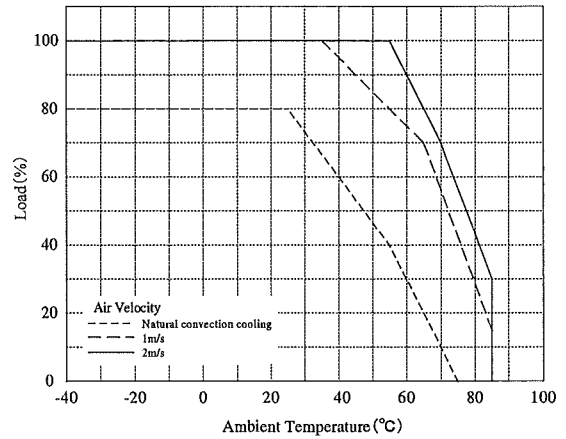

Fig.1-2

PAH200H48-2R5 (include /P, /V, /PV option)

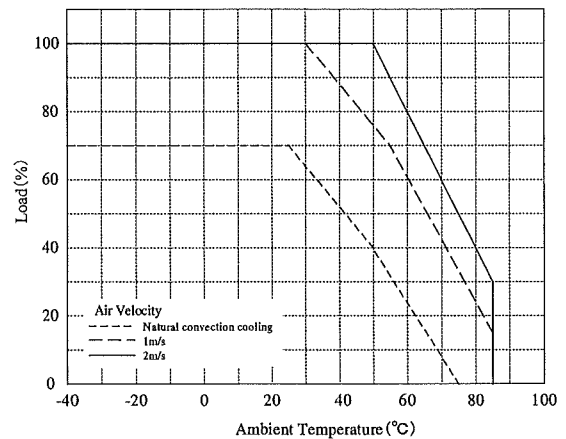

Fig.1-3

PAH200H48-3R3 (include /P, /V, /PV option)

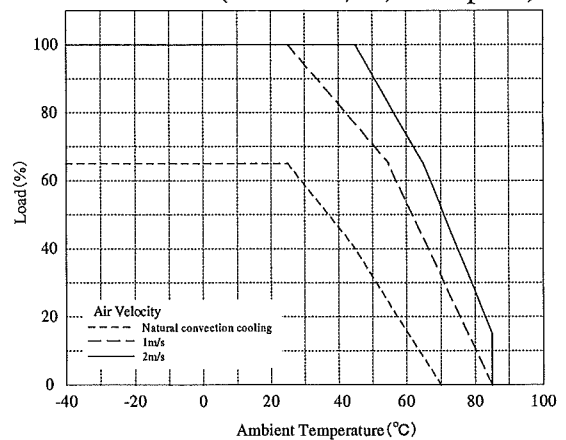

Fig.1-4

PAH200H48-SERIES

(2) Output derating by PCB

When use with different measurement conditions from output derating by ambient temperature, use output derating by PCB temperature as in Fig.1-6.

PCB temperature is decided by temperature of thermal sensor in below Fig.1-5. As the thermal sensor terminals are exposed, when connecting thermocouple, please take sufficient insulation from terminals. Over Thermal Protection of power module is achieved by detecting the PCB temperature through thermal sensor. When the module operates over the output derating curve of PCB temperature, Over Thermal Protection (OTP) functions and output shutdown.

Therefore, measurement of PCB temperature is recommended to ensure the module to operate within the derating curve.

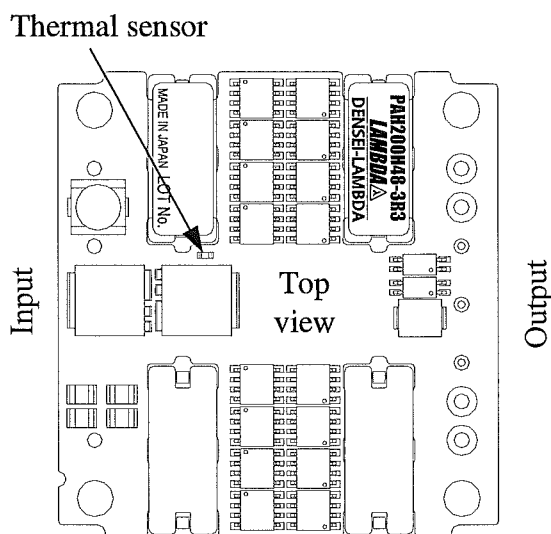

Fig.1-5 Thermal Sensor Position

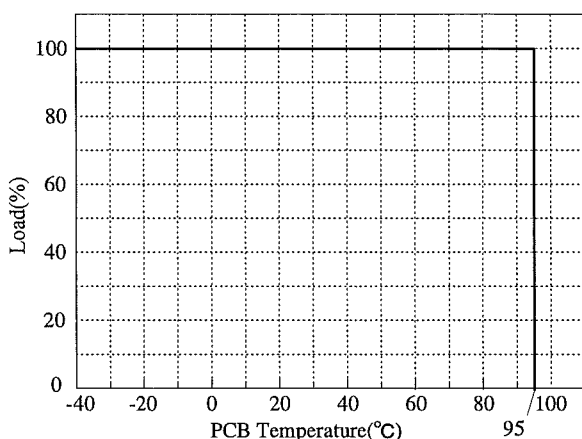

Fig.1-6 Output Derating by PCB Temperature

2. Mounting Method

(1) Mounting hole on PCB

Diameter of hole and land of PCB with referring below.

Type	PAH200H48
Input Terminal Pin	φ 1.0mm
Hole Diameter	φ 1.5mm
Land Diameter	φ 3.0mm
Output Terminal pin	φ 2.0mm
Hole Diameter	φ 2.5mm
Land Diameter	φ 4.5mm
Signal Terminal Pin	φ 1.0mm
Hole Diameter	φ 1.5mm
Land Diameter	φ 3.0mm

For position of the holes, see outline drawing of the power module.

(2) Output Terminal Pin

Connect +V,-V terminal pins such that the contact resistance becomes minimal. Note that large contact resistance could result into reduction of efficiency and abnormal temperature rise at terminal connections

(3) Output Pattern Width

Large output current flows through the output pattern. If pattern is too narrow, voltage drop will occur and heat on pattern will increase. Relationship of current and the pattern width varies depending on materials of printed circuit board, conductor width, maximum allowable temperature rise of the pattern etc.. Confirmation on manufactures of printed circuit board is definitely necessary for designing.

3. Recommended Soldering Method

(1) Soldering dip

260°C within 6seconds

Pre-heat condition

110°C 30~40seconds

(2) Soldering iron

350°C within 3seconds

4. Recommended Cleaning Condition

Recommended cleaning condition after soldering is as follows.

- Cleaning solvent
IPA (isopropyl alcohol)
- Cleaning Procedure
Use brush and dry the solvent completely.

Note) For other cleaning methods, contact us.

■ Before concluding power module damage

Verify following items before concluding power module damage.

1) No output voltage

- Is specified input voltage applied?
- Are the ON/OFF control terminal (CNT terminal), remote sensing terminal(+S,-S), output voltage trimming terminal(TRM) correctly connected?
- For cases where output voltage adjustment is used, is the resistor or variable resistor setting, connections correctly done?
- Are there no abnormalities in the output load used?
- Is the ambient temperature within the specified temperature derating curve?

2) Output voltage is high.

- Are the remote sensing terminals (+S,-S) correctly connected?
- Is the measurement done at the sensing points?
- For cases where output voltage adjustment is used, is the resistor or volume setting, connections correctly done?

3) Output voltage is low

- Is specified input voltage applied?
- Are the remote sensing terminals (+S,-S) correctly connected?
- Is the measurement done at the sensing points?
- For cases where output voltage adjustment is used, is the resistor or variable resistor setting, connections correctly done?
- Are there no abnormalities in the output load used?

4) Load regulation and line regulation is large

- Is specified input voltage applied?
- Are the input terminals and the output terminals firmly connected?
- Is the measurement done at the sensing points?
- Is the input or output wire too thin?

5) Output ripple voltage is large

- Is the measuring method used the same or equivalent with the specified method in the Application Notes?
- Is the input ripple voltage value within the specified value?