

PV/PVD Series

Instruction Manual

BEFORE USING THE POWER SUPPLY UNIT

Pay attention to all warnings and cautions before using the unit.

Incorrect usage could lead to an electrical shock, damage to the unit, or a fire hazard.

WARNING and CAUTION

- Do not touch the internal components that may be hot.
- This power supply is designed for professional installation with end use equipment.
- Confirm connections to input/output terminals are correct as indicated in the instruction manual.
- Attach an external fuse to each module to ensure safety operation and to acquire each safety standard approval.

DWG NO. : C144 - 04 - 01		
APPD	CHK	DWG
<i>A. Kaggama</i>		<i>H. Malodi</i>
23/Jul/99		23/Jul/99

PV/PVD SERIES

1. Terminal Connection

PV1R5

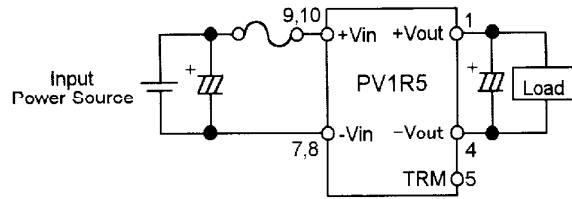

PVD1R5

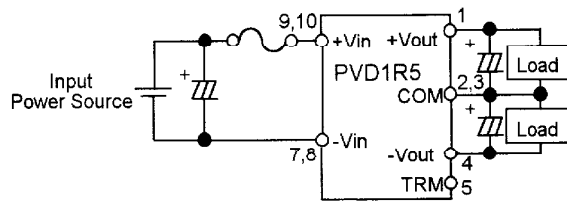

PV3

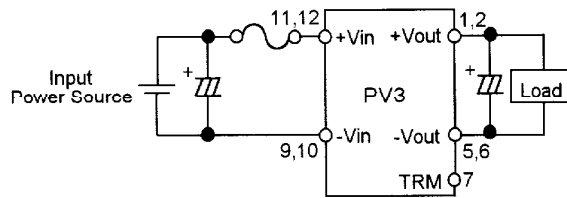

PVD3

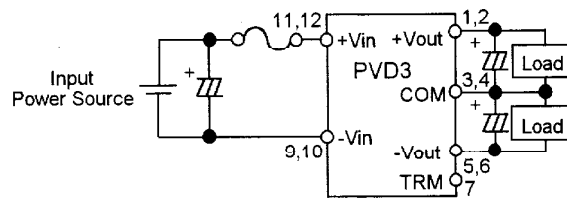

PV/PVD SERIES

2. Explanation of functions and Precautions

2-1 Input Connection

1) Input Fuse

An input fuse is not provided in PV · PVD series, thus attach the Input fuse by yourself.

(The input fuse shall be either a normal blow or a fast blow type.)

Recommended Rated Current for the Input Fuse

Input Voltage	PV/PVD1R5	PV/PVD3
5VDC	2A	3A
12VDC	2A	2A
24VDC	0.5A	1A
48VDC	0.5A	1A

2) Unstable Input Voltage

For input voltage with ripple voltage, the range of the ripple voltage shall be within the input voltage range shown in the specification as the following figure.

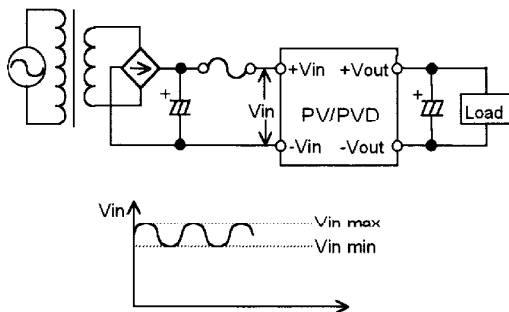

3) Battery

Using battery as input, the minimum and maximum input voltage shall not be sway out of the specification.

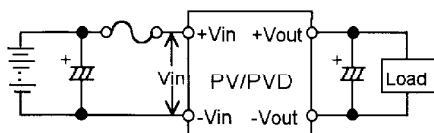

4) Inverse Polarity Input

Wrong polarity of input may lead damage of the unit. In advance, attach a diode and a fuse to avoid damage due to Inverse connection of Input.

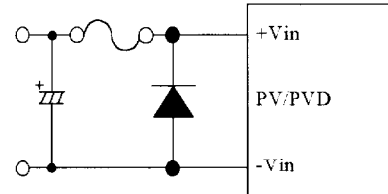

2-2 Input Surge Current

The time input is applied, shortly input surge current flows. To use plural numbers of the units together or to attach an external input capacitor, choose proper current rating of input switch and external fuse.

2-3 Measurement of Output Voltage and Ripple Noise

Measurement values of the output voltage and ripple noise were taken at output terminal of the unit followed by EIAJ RC-9131 (external capacitor: 47 μ F).

Ripple voltage can not measured accurately caused by long ground lead of probe connected to oscilloscope or under the influence of other equipment. Also, it drastically varies due to the range of frequency of oscilloscope.

2-4 Over Current Protection (OCP)

As OCP activates, output voltage drops. To release over current condition, the output voltage is automatically recovered. Being in short or overload condition for more than 30 sec. may cause of damage of the unit.

Due to fold back characteristics of OCP, the output may not rise up with constant current load or inductive load.

PV/PVD SERIES

2-5 Over Voltage Protection

Over Voltage Protection is not provided.

2-6 Input / Output Filter

2-6-1 Input Ripple and Noise

An internal filter is provided in a unit. Certainly it performs without external capacitor, however, to attach the capacitor at input, it effects to reduce the input noise. The external capacitor shall be attached to input terminal.

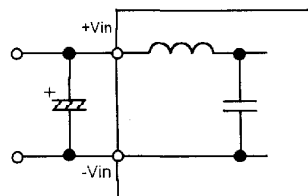

Wire from input power source to the unit is long, the impedance of input line is large and spike noise or inductive of input wires may exert a bad influence on the unit due to high impedance of input wires. In this case, an external capacitor is recommended to attach.

Recommended capacitance of the external capacitor is 0 ~ 220 μ F. Choose a suitable external capacitor in accordance with operating conditions.

2-6-2 Output Ripple and Noise

To reduce the output ripple, 0~220 μ F external capacitor is recommended to attach.

2-6-3 Using Long Load Wires

If noise is generated due to long wiring to load terminal from output terminal, attach a capacitor as close as to load terminal as shown in following figure.

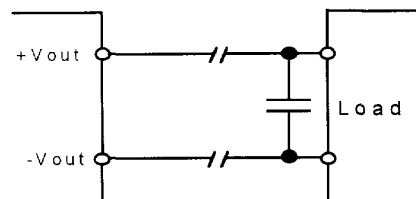

2-6-4 An application of PVD series

PVD series can be used as shown in below figure. In this case, PVD series operate as if single output units.

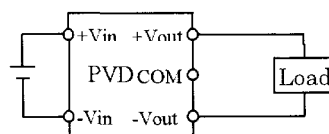

<Balanced load>

Output current value of +Vout and -Vout terminals are approximately equal.

2-7 Output Voltage Adjustment (TRM Terminal)

To connect TRM terminal to -Vout terminal, output voltage can be adjusted as the following table.

Model	Open	-Vout and Short
PV*-*-5	5V	6V
PV*-*-12	12V	15V
PVD*-*-1212	$\pm 12V$	$\pm 15V$

Also, output voltage can be adjusted by attaching a resistor between TRM Terminal and -Vout terminal.

Model	Output Voltage
PV*-*-5	5~6V
PV*-*-12	12~15V
PVD*-*-1212	$\pm 12 \sim \pm 15V$

PV/PVD SERIES

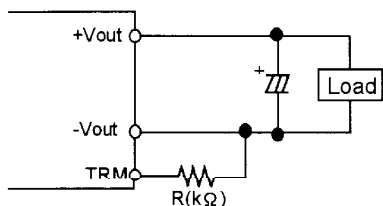

To calculate the output voltage setting, use following equations.

$$\text{PV}^* \text{-} 5 \quad V_{\text{out}} = 5 + 12.775 / (12.7 + R)$$

$$\text{PV}^* \text{-} 12 \quad V_{\text{out}} = 12 + 48.475 / (16.17 + R)$$

$$\text{PVD}^* \text{-} 1212 \quad V_{\text{out}} = 12 + 53.655 / (17.94 + R)$$

(between $\pm V_{\text{out}}$ and COM)

Connection Resistor : $R(k\Omega)$

If the output voltage is modulated to high, operate it with less than the maximum output power.

2-8 Series · Parallel Connections

It is not allowed to connect in either series or parallel to increase the output current.

2-9 Isolation and Withstand Voltage Test

Avoid performing the isolation resistance test with voltage that is over specification. At the withstand voltage test, the voltage shall be gradually increased to apply and decreased to shut down the input. Especially using timer, the impulse voltage several times as the applied voltage may break out at shutting down and cause of damage on the unit.

2-10 Soldering and Cleaning

1) Soldering Temperature

Soldering temperature shall be following range and conditions.

① Dip Soldering ... 260°C within 10 sec.

Preheating Condition: 110°C for 30~40 sec.

② Soldering Iron ... 350°C within 3 sec.

2) Cleaning Method

Recommended cleaning method after soldering is as follows. (Prohibit to use aqueous cleaner.)

① Solvent: IPA

② Procedure

Use a brush to prevent the solvent sink into the unit. The reliability may be deteriorated owing to the solvent penetration.

Note) Contact us if you are going to clean the power supply not followed by the recommended method.

3. Mounting Method

Positions of mounting holes on PCB shall be referred to the following dimensions. (TOP VIEW)
Keep distances more than 1mm to other components.

PV1R5 / PVD1R5

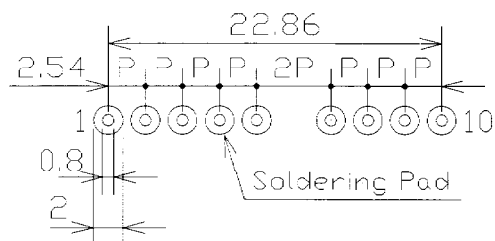

PV3 / PVD3

