

# PYD20 Series Instruction and Application Manual



## Content:

- 1. Product Description.....2
- 2. Product Features .....2
- 3. Intended Use .....2
- 4. Installation Instructions .....3
- 5. Functional Description .....4
- 6. Functional Diagram.....4
- 7. Recommended Wiring Scheme.....5
- 8. Product Nomenclature and List of Models .....6
- 9. Short-form Data .....6
- 10. Efficiency and power dissipation curves .....8
- 11. Physical Dimensions and Pin Layout:.....10
- 12. Isolation and Dielectric Strength.....11
- 13. Protection Features .....11
- 14. Approvals and Regulatory Compliances .....12
- 15. Rail Applications.....12
- 16. Thermal Consideration and Derating .....13
- 17. EMC Considerations .....13
- 18. Remote ON/OFF Function .....15
- 19. Output Voltage Adjustment.....16
- 20. Hold-up Time Circuitry .....17
- 21. Cleaning Process and Soldering Profile.....17

All parameters are typical values specified at nominal input voltage, nominal output load, 25°C ambient and after a 5 minutes run-in time unless otherwise noted. The information presented in this document is believed to be accurate and reliable and may change without notice.

For additional information, please visit <https://product.tdk.com/en/power/py>.

## 1. PRODUCT DESCRIPTION

The PYD20 series are board mount 20W DC-DC converters in a rugged 2 x 1 inch housing with silicone potting. They provide a regulated and galvanically isolated output, available as either single voltage or  $\pm$  dual output voltages.

The most outstanding features of this series are the exceptionally wide input voltage range from 8.5V to 160V (18:1) and the high input/output isolation strength of 3000Vac.

The wide allowed case temperature range from  $-40^{\circ}\text{C}$  to  $+105^{\circ}\text{C}$ , the low heat generation, due to the high efficiencies up to 90% and the high shock and vibration resistance thanks to the potted design make this device suitable for nearly every situation.

Another unique feature is the compliance with the standard EN 50155, which is an international standard covering electronic equipment used on rolling stock for railway applications. In combination with the wide input voltage range, there are many application opportunities in this segment. Further applications for this DC-DC converter can be found in Distributed Power Architecture (DPA), telecommunications, battery-powered devices, measurement and laboratory equipment, devices in industrial environments, and many other areas.

## 2. PRODUCT FEATURES

- 2 x 1 Inch (50.8 x 25.4mm) Industry Standard Footprint
- 3000Vac Input to Output Isolation
- 8.5-160V (18:1) Wide-range Input
- Single or  $\pm$  Dual Output Voltages Available
- EN 50155 Railway Compliant
- IEC 62368-1 (ICT) Approved
- High Shock and Vibration Resistance due to Potted Design
- Efficiency up to 90% and Low No-load Power Consumption
- $-40$  to  $+105^{\circ}\text{C}$  Operating Case Temperature Range
- Remote ON/OFF Input

## 3. INTENDED USE

This device is designed and manufactured as a component part to be mounted on a pc-board and to be installed in electronic devices.

This device is intended for commercial use, such as in industrial control, process control, monitoring and measurement equipment or the like.

Additionally, this device is also designed for equipment that is intended for use in railway rolling stock applications according to EN 50155.

Do not use this device in equipment, where malfunctioning may cause severe personal injury or threaten human life without additional appropriate safety devices, that are suited for the end-application.

If this device is used in a manner outside of its specification, the protection provided by the device may be impaired.

## 4. INSTALLATION INSTRUCTIONS

Before operating this device, please read this manual thoroughly and retain for future reference! This device may only be installed and put into operation by qualified personnel. If damage or malfunction should occur during operation, immediately turn power off and send device to the factory for inspection. The device does not contain serviceable parts.

**⚠ WARNING** Risk of electrical shock, fire, personal injury or death.

Turn power off before working on the device. Protect against inadvertent re-powering.

Do not modify or repair the unit.

Do not open the unit as high voltages are present inside.

Use caution to prevent any foreign objects from entering the housing.

Do not use in locations where flammable gas or ignitable substances are present.

Do not use in wet locations or in areas where moisture or condensation can be expected.

Do not use in environment with strong electromagnetic field, corrosive gas or conductive substances or direct sunlight.

Do not touch during power-on, and immediately after power-off. Hot surfaces may cause burns.

### Obey the following installation instructions:

This device may only be installed and put into operation by qualified personnel.

This device does not contain serviceable parts. Replace fuses only when explicitly permitted. If damage or malfunction should occur during installation or operation, immediately turn power off and send unit to the factory for inspection.

Install the device in an enclosure providing protection against electrical, mechanical and fire hazards.

The device is designed for pollution degree 2 areas in controlled environments. No condensation or frost is allowed.

The input can be powered from batteries or similar DC sources.

Check for correct input polarity. The device will get damaged when the voltage is reversed.

Ensure sufficient cooling to avoid overloading the device.

The device is designed for altitudes up to 5000m (16400ft).

This device is not internally fused. An external input fuse must always be used. Use a 3.15A slow-blow fuse.

The maximum operational case temperature is +105°C (+221°F). The case temperature is defined in the middle of the top side of the cover.

The device is designed to operate in areas with a maximum relative humidity of 95%.

Do not apply return voltages from the load to the output terminals.

Do not connect the outputs of multiple devices in parallel for higher output currents.

Do not connect batteries for charging purposes without additional charging circuit to the output of the device.

## 5. FUNCTIONAL DESCRIPTION

The output is electronically protected against no-load, overload and short circuit. In case of an overload or short circuit, the device will operate intermittently (hiccup mode).

The device can supply resistive and inductive loads.

Avoid loads with large input capacitances. If the capacitive load is higher than the values specified, the device operates in an intermittent mode (hiccup mode).

PYD20-72WS05: max. 6800 $\mu$ F

PYD20-72WS12: max. 3300 $\mu$ F

PYD20-72WS15: max. 2200 $\mu$ F

PYD20-72WD12: max. 820 $\mu$ F

PYD20-72WD15: max. 680 $\mu$ F

PYD20-72WD24: max. 330 $\mu$ F

The  $\pm$  output voltage is generated by one converter. The sum of the two voltages is regulated. The power can be drawn asymmetrically but it is recommended that the less loaded output should take a minimum of 5% of the total load.

For single output voltage models, the output voltage can be adjusted with an external resistor connected between the TRIM-pin and the output voltage.

The device is equipped with an over-temperature protection. In case of a high temperature, the output shuts down and starts automatically after cooling off.

The device is equipped with under-voltage protection on the input side. If the input voltage is too low, the device does not start or switches off.

In case of an internal defect, a redundant circuit prevents the output voltage from becoming excessive or dangerous (zener diode type protection).

The device is equipped with a remote ON/OFF function.

## 6. FUNCTIONAL DIAGRAM

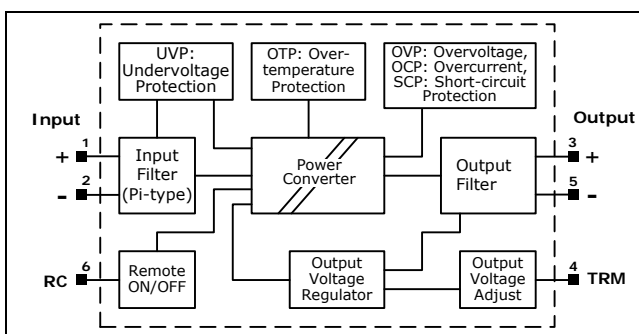

Functional diagram for models with a single output voltage

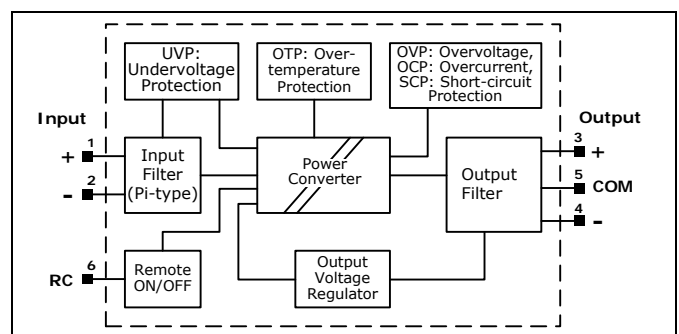

Functional diagram for models with dual output voltages

**RC:** Remote ON/OFF control pin

**TRM:** Trim pin for output voltage adjustment

All parameters are typical values specified at nominal input voltage, nominal output load, 25°C ambient and after a 5 minutes run-in time unless otherwise noted. The information presented in this document is believed to be accurate and reliable and may change without notice.

For additional information, please visit <https://product.tdk.com/en/power/py>.

## 7. RECOMMENDED WIRING SCHEME

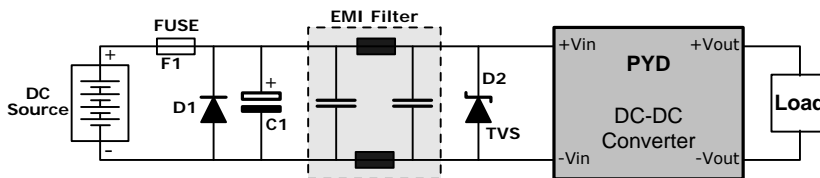

**Fuse F1:** The DC-DC converter is not internally fused. An external input fuse must always be used. Use a 3.15A slow-blow fuse.

**Diode D1:** The diode provides a reverse input polarity protection. In case of a reversed polarity, the fuse will open and protect the converter.

In applications where the input voltage can be reversed, it is advisable to install such a protection. Schottky diodes are most suitable for this purpose. The current should be at least 1.5 times the tripping current of the fuse. The voltage rating of the diode should be at least equal to the maximum possible input voltage.

**Capacitor C1 and Diode D2:** These two components provide higher transient resistance (surge and burst) at the input and are required if the DC-DC converter has to meet the EN61000-4-4 and EN61000-4-5 standard. The capacitor should be 220 $\mu$ F and the suppressor diode should be a SECOS SMDJ180A-C.

**EMI Filter:** This filter reduces the conducted emission to the input. Circuit examples for a class A filter can be found in the chapter "EMC Considerations".

## 8. PRODUCT NOMENCLATURE AND LIST OF MODELS

### Product Nomenclature:

PY	a	bb	-	ccc	d	ee	-	z
Family Name PY	Size D = 2 x 1"	Output Power 20 = 20W		Input Voltage 72W = 8.5-160V	Output Type S = Single Output D = Dual Output	Output Voltage 05 = 5V 12 = 12V or ±12V 15 = 15V or ±15V 24 = ±24V		Options Remote ON/OFF: Blank = Pos. Logic N = Negative Logic

### Model list:

<b>PYD20-72WS05</b>	DC-DC converter isolated, 20W, Input: 8.5-160V, Output: 5V 4A, 2x1 inch, pcb-mount
<b>PYD20-72WS12</b>	DC-DC converter isolated, 20W, Input: 8.5-160V, Output: 12V 1.67A, 2x1 inch, pcb-mount
<b>PYD20-72WS15</b>	DC-DC converter isolated, 20W, Input: 8.5-160V, Output: 15V 1.33A, 2x1 inch, pcb-mount
<b>PYD20-72WD12</b>	DC-DC converter isolated, 20W, Input: 8.5-160V, Output: ±12V ±0.83A, 2x1 inch, pcb-mount
<b>PYD20-72WD15</b>	DC-DC converter isolated, 20W, Input: 8.5-160V, Output: ±15V ±0.67A, 2x1 inch, pcb-mount
<b>PYD20-72WD24</b>	DC-DC converter isolated, 20W, Input: 8.5-160V, Output: ±24V ±0.42A, 2x1 inch, pcb-mount

Output voltages of 24Vdc, 30Vdc or 48Vdc can be achieved by the sum voltage of dual output voltage models. In such cases the COM pin is left open.



## 9. SHORT-FORM DATA

Input voltage range	Min. 8.5Vdc Nom. 72Vdc Max. 160Vdc	
Input current at no load	Max. 5mA Max. 8mA	For PYD20-72WS05 For all other models
Input current at remote OFF	Typ. 3mA Max. 5mA	For all models For all models
Output power	Max. 20W	For all models
Output current	Nom. 4.0A <sup>1)</sup> Nom. 1.67A <sup>1)</sup> Nom. 1.33A <sup>1)</sup> Nom. ±0.833A <sup>1)</sup> Nom. ±0.667A <sup>1)</sup> Nom. ±0.417A <sup>1)</sup>	For 5V model For 12V model For 15V model For ±12V model For ±15V model For ±24V model
Output voltage adjustment range	Max. -20%/+15% Not adjustable	For single output voltage models For dual output voltage models

All parameters are typical values specified at nominal input voltage, nominal output load, 25°C ambient and after a 5 minutes run-in time unless otherwise noted. The information presented in this document is believed to be accurate and reliable and may change without notice.

For additional information, please visit <https://product.tdk.com/en/power/py>.

## DC-DC Converter Isolated, 20W, 2x1", PCB Mount

Output voltage accuracy range		±1%	Factory setting
Line regulation	Max.	±0.2%	Between 8.5 and 160Vdc
Load regulation	Max.	±0.2%	For single output models
	Max.	±1.0%	For dual output models
Transient response recovery time		250µs	For a 75% to 100% load step
Cross regulation (dual models)	Max.	±5%	Asymmetrical load 25%/100%
Temperature coefficient	Max.	±0.02%/°C	
Start-up time	Typ.	15ms	For 5V output
	Typ.	10ms	For all other models
Ripple and noise voltage			For resistive load, after applying an input voltage or remote ON signal and reaching 95% of output voltage
	Max.	75mVp-p	For 5V output
	Max.	100mVp-p	For all other models
Efficiency			Bandwidth 20MHz, and 1µF capacitor
	Max.	40mV rms	For all models
Operational temperature range	Typ.	86.0% to 90.0%	At 72Vdc, full load, depending on model
	Typ.	85.0% to 89.0%	At 110Vdc, full load, depending on model
Operational temperature range		-40°C to +105°C	See chapter "Thermal Considerations" for derating requirements
Case temperature	Max.	+105°C	
Storage temperature rang		-55°C to +125°C	
Relative humidity	Max.	95% RH	No condensation allowed
Altitude	Max.	5000m / 16 400ft	
Atmospheric pressure		110-54kPa	
Vibration		20Hz-1kHz: 0.04g <sup>2</sup> /Hz 1-2kHz: -6dB/octave 60 minutes per axis	According to MIL-STD-810F, random vibration, units are operational
Shock		50 g, 11 ms 18 shocks (3 shocks for each ±axis)	According to MIL-STD-810F, units are operational
Size		50.8x 25.4x 10.2mm 2 x 1 x 0.4"	Length x Width x Height
Weight		28.5g / 0.063lb	
MTBF		1 242 000h	For 5V model
		1 397 000h	For 12V model
		1 631 000h	For 15V model
		1 341 000h	For ±12V model
		1 571 000h	For ±15V model
		1 622 000h	For ±24V model
			Acc. to MIL HDBK 217F at full load, GB25°C

- 1) This is the nominal current which must not be exceeded even at lower tuned output voltages. At higher output voltages, the current is reduced according to the nominal power. Below 12Vdc the continuous output power is reduced according to the following curve:

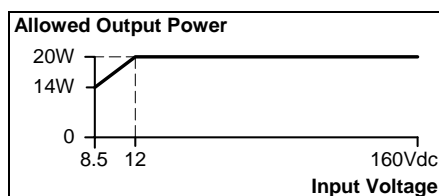

All parameters are typical values specified at nominal input voltage, nominal output load, 25°C ambient and after a 5 minutes run-in time unless otherwise noted. The information presented in this document is believed to be accurate and reliable and may change without notice.

For additional information, please visit <https://product.tdk.com/en/power/py>.

## 10. EFFICIENCY AND POWER DISSIPATION CURVES

PYD20-72WS05: Efficiency and power losses vs. output load

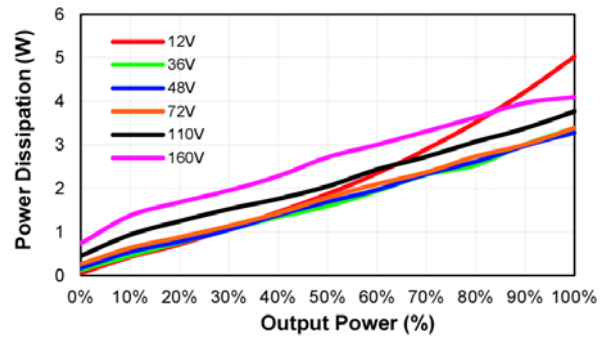
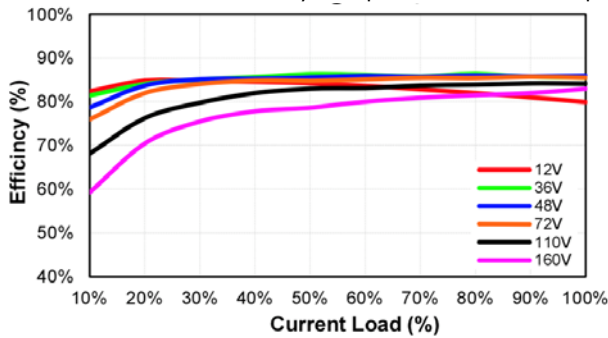

PYD20-72WS12: Efficiency and power losses vs. output load

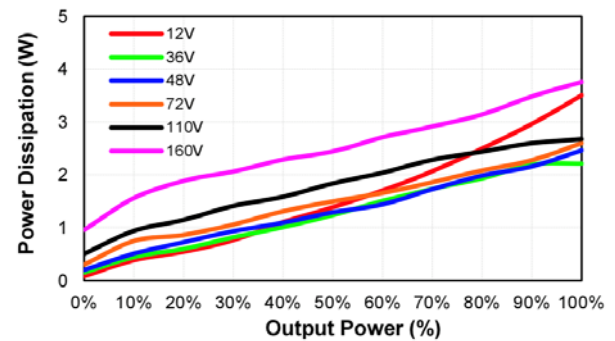
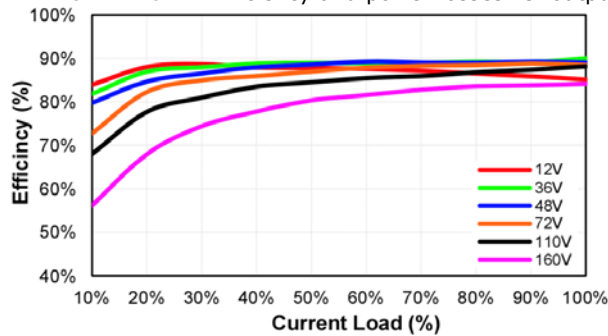

PYD20-72WS15: Efficiency and power losses vs. output load

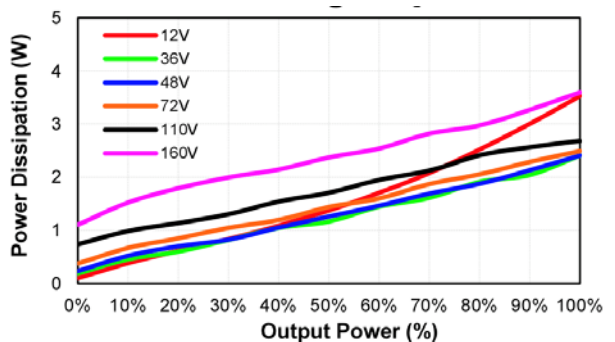
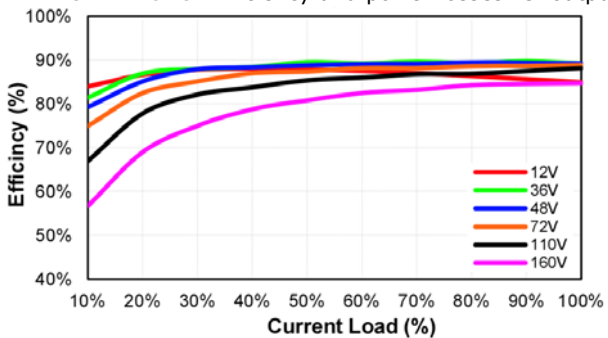

PYD20-72WD12: Efficiency and power losses vs. output load

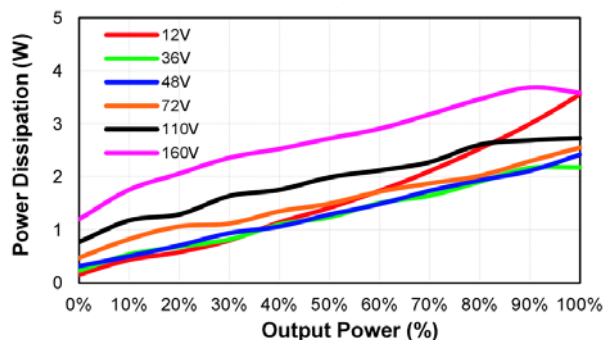
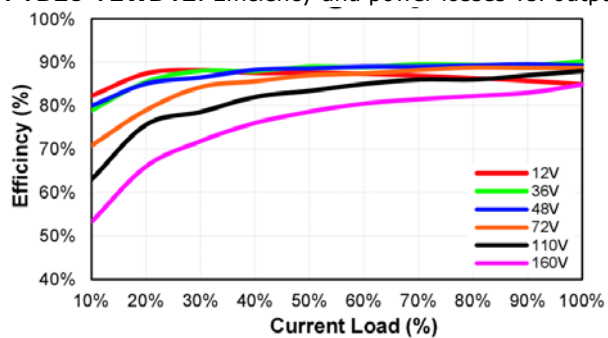

All parameters are typical values specified at nominal input voltage, nominal output load, 25°C ambient and after a 5 minutes run-in time unless otherwise noted. The information presented in this document is believed to be accurate and reliable and may change without notice.

For additional information, please visit <https://product.tdk.com/en/power/py>.



DC-DC Converter Isolated, 20W, 2x1", PCB Mount

PYD20-72WD15: Efficiency and power losses vs. output load

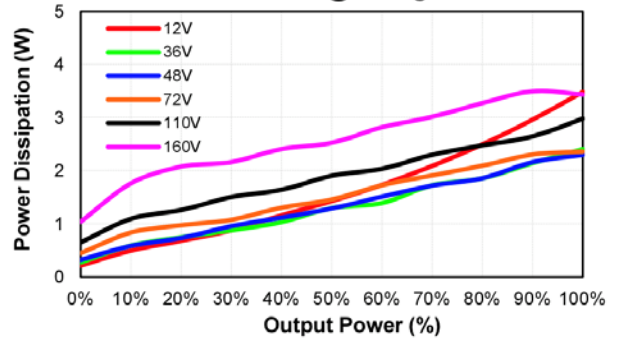
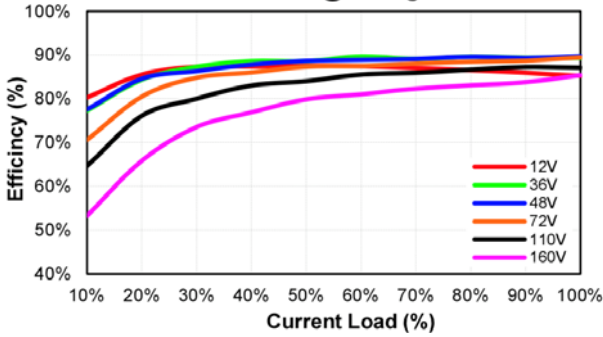

PYD20-72WD24: Efficiency and power losses vs. output load

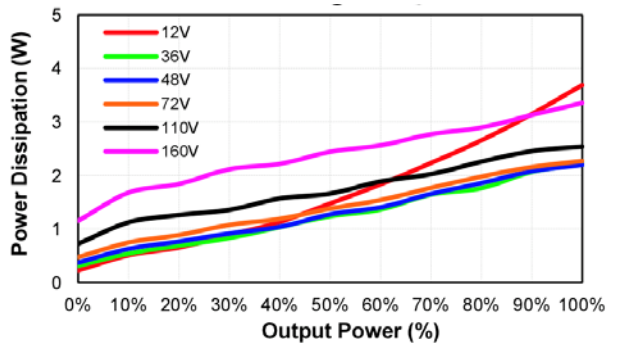
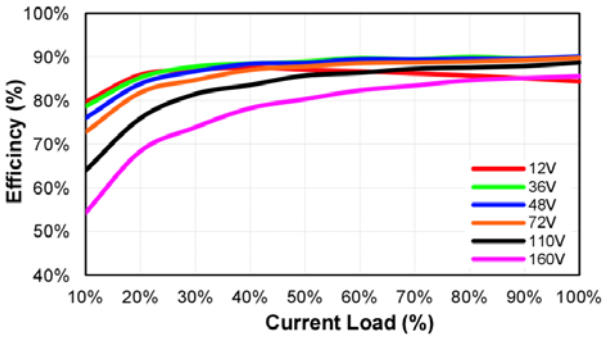

All parameters are typical values specified at nominal input voltage, nominal output load, 25°C ambient and after a 5 minutes run-in time unless otherwise noted. The information presented in this document is believed to be accurate and reliable and may change without notice.

For additional information, please visit <https://product.tdk.com/en/power/py>.

## 11. PHYSICAL DIMENSIONS AND PIN LAYOUT:

Length	50.8mm, 2.0"
Width	25.4mm, 1.0"
Height	10.2mm, 0.4"
Weight	28.5g / 0.063lb
Case material	Plastic
Potting material	Silicone
Pin material	Base: copper Plating: nickel with matte tin

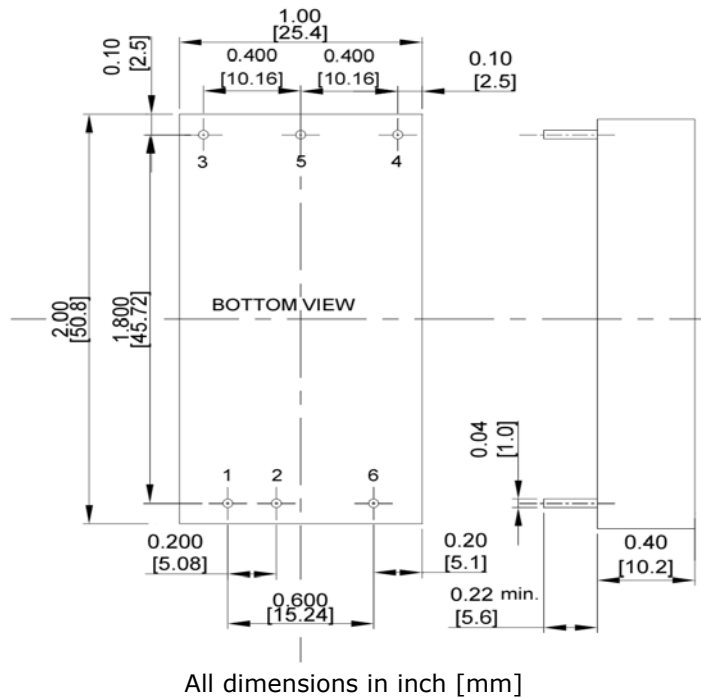

### Inch tolerances:

$x.xx \pm 0.02$ ,  $x.xxx \pm 0.01$

Pin diameter  $\pm 0.004$

### Millimeter tolerances:

$x.x \pm 0.5$ ,  $x.xx \pm 0.25$

Pin diameter  $\pm 0.10$

### Pad size recommendations (all pads)

Through hole:  $\Phi 0.051$  [1.30]

Top view pad:  $\Phi 0.064$  [1.63]

Bottom view pad:  $\Phi 0.102$  [2.60]

### Pin assignment

Pin	Single output	Dual outputs
1	+V Input	+V Input
2	-V Input	-V Input
3	+V Output	+V Output
4	TRIM	-V Output
5	-V Output	COM
6	R/C	R/C

## 12. ISOLATION AND DIELECTRIC STRENGTH

The output voltage is floating and has no ohmic connection to the input. Hi-pot tests may be repeated by the customer using appropriate test equipment, which applies the voltage with a slow ramp (2s up and 2s down). Connect all input-terminals together as well as all output poles before conducting the test.

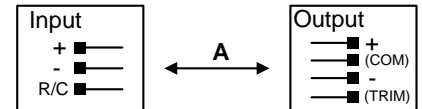

Dielectric strength	Min. 3000Vac or Min. 4200Vdc	Input to output for 1 minute
Isolation resistance	Min. 1 GΩ	Measured at 500Vdc
Isolation capacitance	Typ. 20pF	Input to output

## 13. PROTECTION FEATURES

Under voltage protection (UVP) Turn-On voltage	Min. 8.5Vdc Typ. 9.0Vdc Max. 9.5Vdc	For all models at 70% load
Under voltage protection (UVP) Shut-down voltage	Min. 7.0Vdc Typ. 7.5Vdc Max. 8.0Vdc	For all models at 70% load, 1.5V lock-out hysteresis voltage
Input surge voltage	Max. 200Vdc	For maximal 100ms
Output over voltage protection (OVP)	6.2Vdc 15Vdc 18Vdc ±15Vdc ±18Vdc ±30Vdc	Zener diode type For 5V output For 12V output For 15V output For ±12V output For ±15V output For ±24V output
Output over-current protection (OCP)	Min. 110% Typ. 150% Max. 180%	Of nominal output current, intermittent operation (hiccup mode)
Output short-circuit protection (SCP)	Included	Continuous, automatic recovery
Over temperature protection (OTP)	Typ. 110°C	Case temperature, Automatic recovery when temperature falls below 92°C
Reverse input polarity protection	Not included	Use external protection diode if required
Degree of pollution	2	According to IEC 60664-1, not conductive

All parameters are typical values specified at nominal input voltage, nominal output load, 25°C ambient and after a 5 minutes run-in time unless otherwise noted. The information presented in this document is believed to be accurate and reliable and may change without notice.

For additional information, please visit <https://product.tdk.com/en/power/py>.

## 14. APPROVALS AND REGULATORY COMPLIANCES

CE	EU Declaration of Conformity includes Low-Voltage and RoHS Directive
UKCA	UK Declaration of Conformity includes Electrical Safety and RoHS Directive
EN 62368-1	Safety requirements for audio/video, information and communication technology equipment
UL 62368-1	Recognized component for audio/video, information and communication technology equipment, E-File E133400, Categories QQJQ2 and QQJQ8

## 15. RAIL APPLICATIONS

The DC-DC converter with additional circuits is tested according to the following standards and is suitable for railroad applications. For details see application note for railway application

EN 50155	Railway applications - Rolling stock - Electronic equipment
EN 45545-2	Fire protection on railway vehicles - Part 2: Requirements for fire behaviour of materials and components
EN 61373	Railway applications - Rolling stock equipment - Shock and vibration tests
EN 50121-3-2	Railway applications - Electromagnetic compatibility - Part 3-2: Rolling stock - Apparatus

## 16. THERMAL CONSIDERATION AND DERATING

The DC-DC converters operate over a wide temperature range. Even if the heat generated by the DC-DC converters are very low, it must be removed. This can be done either by convection cooling, forced air cooling or radiation.

It is important that the enclosure temperature at the indicated temperature reference point does not exceed the maximum enclosure temperature, which is 105°C.

If the DC-DC converter is used in vertical mounting position with natural convection cooling without airflow obstruction, the following output loads can be powered depending on the ambient (air) temperature.

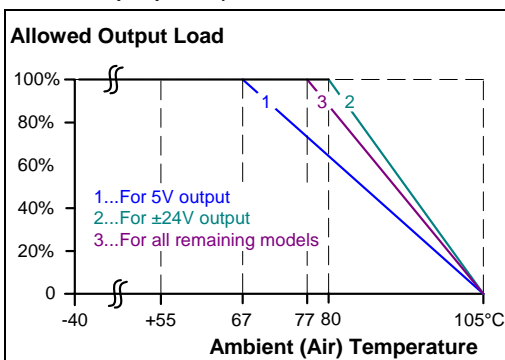
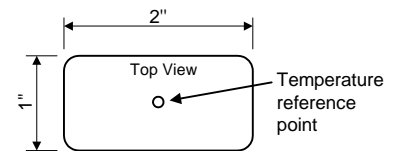

The derating is not hardware controlled. The user has to take this into consideration to stay below the derated current limits in order not to overload the unit.

## 17. EMC CONSIDERATIONS

In terms of EMC, this DC-DC converter module is considered a component for installation in an end device by a device manufacturer. In order to meet all the requirements of the end device, additional components may have to be deployed and final EMC measurements must be carried out in the end application.

The following tests and measurements were performed according to EN 55032 and EN 50121-3-2 (emission) and EN 55024 and EN 50121-3-2 (immunity).

All tests and measurements were carried out with standardized test set-ups.

### EMC Immunity

Electrostatic discharge	EN 61000-4-2	Air discharge	±8kV	Criterion A
		Contact discharge	±6kV	Criterion A
Electromagnetic RF field	EN 61000-4-3	80MHz-1GHz	20V/m	Criterion A
Fast transients (Burst)	EN 61000-4-4	Input, with additional components see note 1)	±2kV	Criterion A
Surge voltage	EN 61000-4-5	Input, with additional components see note 1)	±2kV	Criterion A
Conducted disturbance	EN 61000-4-6	0.15-80MHz	10V	Criterion A

**Performance criterion A:** The device shows normal operation behavior within the defined limits.

**Note 1)** Burst and surge tests were performed with an additional 100µF/200V capacitor and 180V suppressor diode SMCJ180A.

All parameters are typical values specified at nominal input voltage, nominal output load, 25°C ambient and after a 5 minutes run-in time unless otherwise noted. The information presented in this document is believed to be accurate and reliable and may change without notice.

For additional information, please visit <https://product.tdk.com/en/power/py>.

## DC-DC Converter Isolated, 20W, 2x1", PCB Mount

### EMC Emission

#### Recommended external EMI filter for EN 55011, EN 55032 Class A and EN 50121-3-2

The placement of components and the routing of traces on the pc-board must be carried out according to EMC aspects. If help is needed, please contact our technical support team.

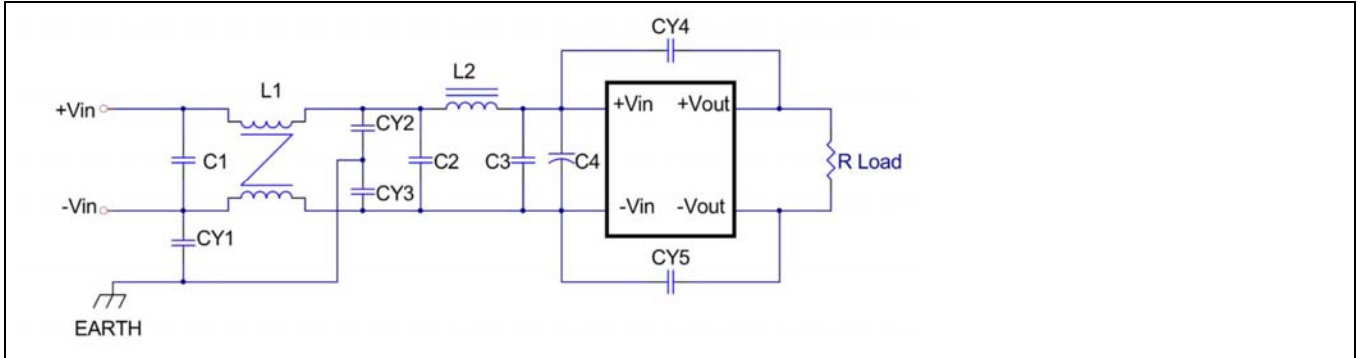

BOM	C1, C2, C3	C4	CY1	CY2, CY3	CY4, CY5	L1	L2
Models with single output	10F/250V 1812	120µF/220V NCC KXJ	680pF, 400Vac Y1 capacitor TDK CD series	1.5nF, 400Vac Y1 capacitor TDK CD series	2.2nF, 400Vac Y1 capacitor TDK CD series	1.4mH Ø0.4mmx1/13T	10uH/7A
Models with dual output	X7R Ceramic capacitor	Aluminum capacitor	470pF, 400Vac Y1 capacitor TDK CD series			ACME A151 T10x5x5C	2525CZ Vishay

### Switching Frequency

Main converter	Min.	180kHz	Fixed frequency
	Typ.	200kHz	
	Max.	220kHz	

All parameters are typical values specified at nominal input voltage, nominal output load, 25°C ambient and after a 5 minutes run-in time unless otherwise noted. The information presented in this document is believed to be accurate and reliable and may change without notice.

For additional information, please visit <https://product.tdk.com/en/power/py>.

## 18. REMOTE ON/OFF FUNCTION

The device is equipped with a remote ON/OFF function to turn the output ON or OFF.

Two logics are possible. With the positive logic (standard version), the output switches OFF as soon as pin 2 (-Vin) and pin 6 (RC) are linked or a voltage of less than 1.2V is present.

The optionally available negative logic (option -N) is exactly the vice versa. Here the output switches ON as soon as pin 2 (-Vin) and pin 6 (RC) are linked or a voltage of less than 1.2V is present.

The RC-input is a sink input, which requires a maximal current of 1mA (typically 0.4mA) to be activated. The maximal allowed voltage (open circuit voltage) for this pin is 160Vdc.

### Positive logic (standard)

Converter ON: open or 4-160V

Converter FF: closed or 0-1.2V

### Negative logic (option -N)

Converter ON: closed or 0-1.2V

Converter FF: open or 4-160V

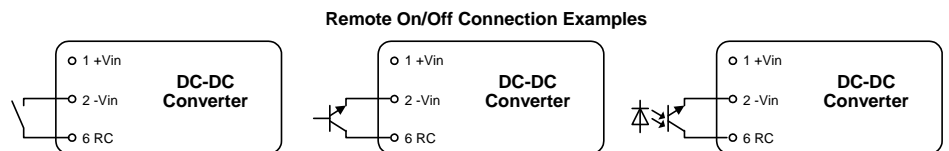

## 19. OUTPUT VOLTAGE ADJUSTMENT

For models with only one output, the output voltage can be adjusted in the range of -20%/+15%.

To increase the output voltage, connect an external resistor between the TRIM-Pin and the negative output voltage (-Vout) and to decrease the voltage, connect the resistor between the TRIM-Pin and the positive output voltage (+Vout).

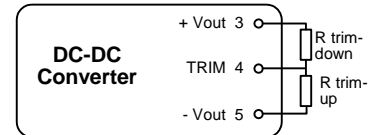

### Resistor values for adjusting the 5V output model

<b>Output (V)</b>	4.0	4.2	4.4	4.6	4.8	<b>5V</b>	5.15	5.3	5.45	5.6	5.75
	-20%	-16%	-12%	-8%	-4%		+3%	+6%	+9%	+12%	+15%
<b>R-up (Ω)</b>	-	-	-	-	-	-	17160	6650	3140	1390	340
<b>R-down (Ω)</b>	290	1790	4280	9270	24240	-	-	-	-	-	-

### Resistor values for adjusting the 12V output model

<b>Output (V)</b>	9.6	10.08	10.56	11.04	11.52	<b>12V</b>	12.36	12.72	13.08	13.44	13.8
	-20%	-16%	-12%	-8%	-4%		+3%	+6%	+9%	+12%	+15%
<b>R-up (Ω)</b>	-	-	-	-	-	-	93820	37910	19270	9950	4360
<b>R-down (Ω)</b>	1550	8700	20630	44490	116060	-	-	-	-	-	-

### Resistor values for adjusting the 15V output model

<b>Output (V)</b>	12.0	12.6	13.2	13.8	14.4	<b>15V</b>	15.45	15.9	16.35	16.8	17,25
	-20%	-16%	-12%	-8%	-4%		+3%	+6%	+9%	+12%	+15%
<b>R-up (Ω)</b>	-	-	-	-	-	-	83770	32890	15920	7440	2350
<b>R-down (Ω)</b>	3050	10590	23140	48250	123590	-	-	-	-	-	-

Please note that the adjustment range at very low input voltages is slightly limited for the 12V and 15V model.

PYD20-72WS12: Reduced trim range at input voltages below 10Vdc

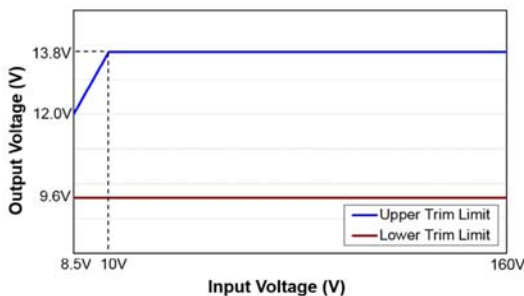

PYD20-72WS15: Reduced trim range at input voltages below 10Vdc

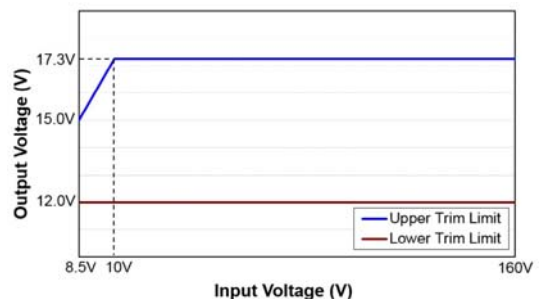

All parameters are typical values specified at nominal input voltage, nominal output load, 25°C ambient and after a 5 minutes run-in time unless otherwise noted. The information presented in this document is believed to be accurate and reliable and may change without notice.

For additional information, please visit <https://product.tdk.com/en/power/py>.



## 20. HOLD-UP TIME CIRCUITRY

The hold time is defined as the time period during which the DC-DC converter output remains active after a loss of input power. The DC-DC converter itself is not capable of providing a hold time. For this, an external circuit with a large hold-up (storage capacitor) is required. The lower the operating voltage of the system, the larger this hold-up capacitor must be.

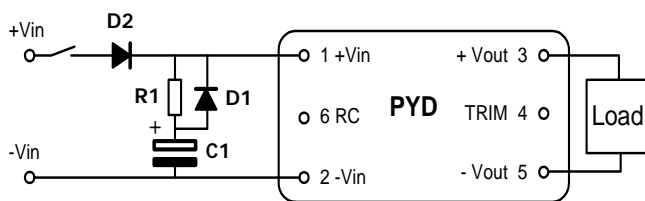

**D1, D2:** 200V/10A

**D2:** To prevent the stored energy from flowing in the wrong direction and not being available for the DC-DC converter. Use only if needed.

**R1:** 100Ω, 10W

**C1:** see table below, voltage must be larger than the supply voltage

### Sizing the hold-up capacitor

Input Voltage	24Vdc	36Vdc	48Vdc	72Vdc	96Vdc	110Vdc
Hold-up capacitor (C1) for 10ms	1100μF	460μF	250μF	110μF	68μF	50μF
Hold-up capacitor (C1) for 30ms	3300μF	1400μF	750μF	330μF	200μF	150μF

## 21. CLEANING PROCESS AND SOLDERING PROFILE

### Cleaning process

Clean the soldered side of the module with a brush, prevent liquid from getting into the module. Do not clean by soaking the module into liquid. Do not allow solvent to come in contact with product labels or resin case as this may change the color of the resin case or cause deletion of the letters printed on the product label. After cleaning, dry the modules well.

### Hand soldering

The suggested soldering iron is 420±10°C for up to 4~15seconds (less than 90W).

### Lead free wave soldering

Lead Free Wave Soldering Profile

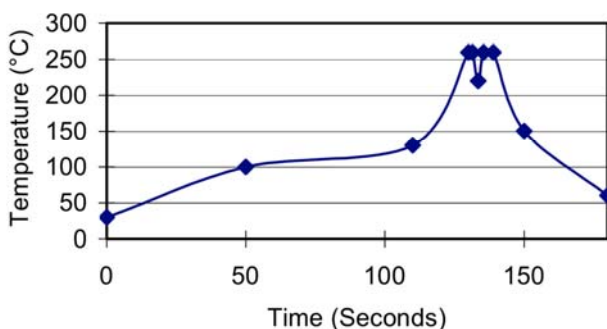

All parameters are typical values specified at nominal input voltage, nominal output load, 25°C ambient and after a 5 minutes run-in time unless otherwise noted. The information presented in this document is believed to be accurate and reliable and may change without notice.

For additional information, please visit <https://product.tdk.com/en/power/py>.