

# PAH150S48-\*

## RELIABILITY DATA



POWER MODULE

DRAWING NO. : PA548-79-01A		
NLS R&D		
PREPARED	CHECKED	APPROVED
<i>Chase</i> 6/12/99	<i>YEO.</i> 6/12/99	<i>[Signature]</i> 6/12/99
DATE ISSUE : 6/12/99		

## INDEX

	PAGE
1) Calculated Value Of M.T.B.F	1
2) Component Derating	2
3) Main Components Temperature Rise $\Delta T$ List	4
4) Abnormal Test	5
5) Vibration Test	9
6) High Temperature Storage Test	10
7) Low Temperature Storage Test	11
8) Resistance To Soldering Heat Test	12
9) Thermal Shock Test	13

Note :- Test result are typical data. Nevertheless the following result are consider to be actual capability data because all units have nearly the same charateristics.

## 1. Calculated Values Of M.T.B.F

MODEL :- PAH150S48-5

### 1 . Method of calculation

Calculated based on part count reliability projection of MIL-HDBK-217F.

Individual failure rate  $\lambda_G$  is given to each part, and MTBF is calculated by the count of each part.

Formula :

$$\begin{aligned} \text{MTBF} &= \frac{1}{\lambda_{\text{equip}}} \\ &= \frac{1}{\sum_{i=1}^n N_i (\lambda_G \pi_Q)_i} \times 10^6 \text{ Hours} \end{aligned}$$

Where :

$\lambda_{\text{equip}}$  : Total Equipment Failure Rate (Failure /  $10^6$  Hours)

$\lambda_G$  : Generic Failure Rate for The ith Generic Part (Failure /  $10^6$  Hours)

$N_i$  : Quantity of ith Generic Part

$n$  : Number of Different Generic Part Categories

$\pi_Q$  : Generic Quality Factor for The ith Generic Part ( $\pi_Q = 1$ )

### 2 . MTBF Values

$G_F$  : (GROUND, FIXED)

$$\text{M T B F} = \quad \mathbf{408,704 \text{ Hours}}$$

## 2. Component Derating

MODEL : PAH150S48-5

### (1) Calculating Method

#### (a) Measuring Conditions

Input Voltage	:	48VDC
Output Current	:	5V, 30A (100%)
Mounting Method	:	Standard Mounting Method (with Heatsink)
Ambient Temperature	:	25°C
Base-Plate Temperature	:	100°C

#### (b) Semiconductors

Compared with maximum junction temperature and actual one which is calculated based on case temperature, power dissipation and thermal impedance.

#### (c) IC, Resistors, Capacitors, etc.

Ambient temperature, operating condition, power dissipation, etc are within derating criteria.

#### (d) Calculating Method of Thermal Impedance

$$\theta_{j-c} = \frac{T_{j(max)} - T_c}{P_{(max)}} \qquad \theta_{j-a} = \frac{T_{j(max)} - T_a}{P_{(max)}}$$

$T_c$  = Case Temperature at Start Point of Derating, 25°C in General

$T_a$  = Ambient Temperature at Start Point of Derating, 25°C in General

$P_{(max)}$  = Maximum Power Dissipation

$T_{j(max)}$  = Maximum Junction Temperature

$\theta_{j-c}$  = Thermal Impedance between Junction and Case

$\theta_{j-a}$  = Thermal Impedance between Junction and Air

**2. Temperature Derating**

Model :- PAH150S48-5

Condition :- Vin = 48 VDC  
Load = 100 %  
Tp = 100°C

Symbol	Parts Name	Catalog No	Tj max (°C)	Actual Tj (°C)	Derating factor (%)
Q1	CHIP MOSFET	2SK1334BY-TL	150	118.05	78.70
Q2	CHIP TRANSISTOR	2SC2712Y-TE85L	125	104.10	83.28
Q3	CHIP TRANSISTOR	2SA1162Y-TE85L	150	95.90	63.93
A1	CHIP IC	NL21C001	150	123.45	82.30
A2	CHIP IC	HA17431UA-04-TL	150	91.6	61.06
A3	CHIP IC	IR2110S	150	129.40	86.27
A4	CHIP IC	TA75S393F-TE85L	125	101.5	81.2
A5	CHIP IC	OPA2244EA	125	92.1	73.68
A6	CHIP IC	LM4041CIM3-1.2	150	90	60
A7	CHIP IC	TA75S01F-TE85L	125	101.9	81.52
D1	CHIP DIODE, U-LLD	D1FL20U-4063	150	106.39	70.93
D2	CHIP DIODE	1SS184-TE85L	150	120.80	80.53
D3	CHIP DIODE, U-LLD	D1FL20U-4063	150	107.13	71.42
D4	CHIP DIODE	1SS184-TE85L	150	119.76	79.84
D5	CHIP DIODE	1SS181-TE85L	125	101.6	81.28
ZD1	CHIP ZENER	02CZ18Y-TE85L	150	109.80	73.20
ZD2	CHIP ZENER	02CZ3.6Z-TE85L	150	105.28	70.18
ZD3	CHIP ZENER	02CZ12Z-TE85L	150	102.10	68.07
ZD4	CHIP ZENER	02CZ2.2Z-TE85L	150	99.4	66.26
PC1	CHIP PHOTO COUPLER	TLP181GRH-TPL	150	95.34	63.56
PC2	CHIP PHOTO COUPLER	TLP181GRH-TPL	150	90.20	60.13
Q101	CHIP MOSFET	2SK2099-01S	150	113.70	75.80
Q102	CHIP MOSFET	2SK2226-01S	150	118.98	79.32
D101	CHIP S.B.D	DF30SC3ML	150	118.84	79.23
D102	CHIP S.B.D	DF30SC3ML	150	120.44	80.29
ZD101	CHIP ZENER	02CZ18Y-TE85L	150	102.00	68.00

### 3. Main Components Temperature Rise $\Delta T$ List

**MODEL : PAH150S48-5**

Location	Parts Name	Catalog No.	$\Delta T_{C-P}$ (°C)
Q101	CHIP MOSFET	2SK2099-01S	5.9
Q102	CHIP MOSFET	2SK2226-01S	10.1
D101	CHIP S.B.D	DF30SC3ML	7.8
D102	CHIP S.B.D	DF30SC3ML	9.4
ZD101	CHIP ZENER	02CZ18Y-TE85L	2.0
C102	CHIP CAP., CERAMIC	THP60E2A685ZT992	3.0
C103	CHIP CAP., CERAMIC	GHM1530X7R473K250PT	4.1
C106	CHIP CAP., CERAMIC	THP60E1E476ZT992	0.3
L101	CHIP COIL	HA-841R5X	11.0
L102	RING CORE	4330 030 6029	-7.0
C27	CHIP CAP., TANTALUM	F941A336MC	-13.8
T101	COIL (SEC)		13.9
T102	COIL (SEC)		11.8
	CONTROL PCB (A3)		9.3
	POWER PCB (D102)		2.1

#### Measuring Conditions

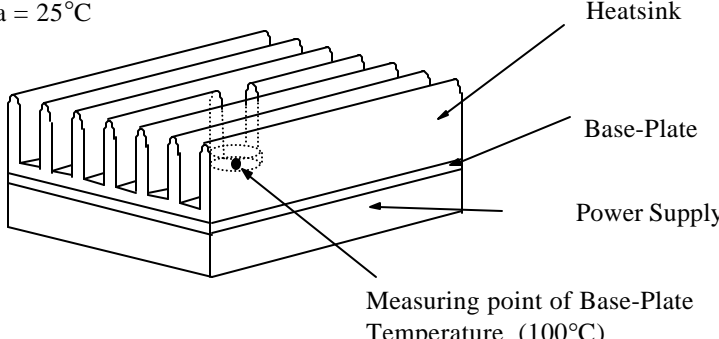
Mounting Method	Standard Mounting Method (with Heatsink)  $T_a = 25^\circ\text{C}$ 
Input Voltage	48VDC
Output Voltage	5VDC
Output Current	30A (100%)

$\Delta T_{C-P}$  : Differential temperature between component and base-plate; with power supply fitted with heatsink, baseplate temperature = 100°C and ambient temperature = 25°C.

4. Abnormal Test

Model :- PAH150S48-5

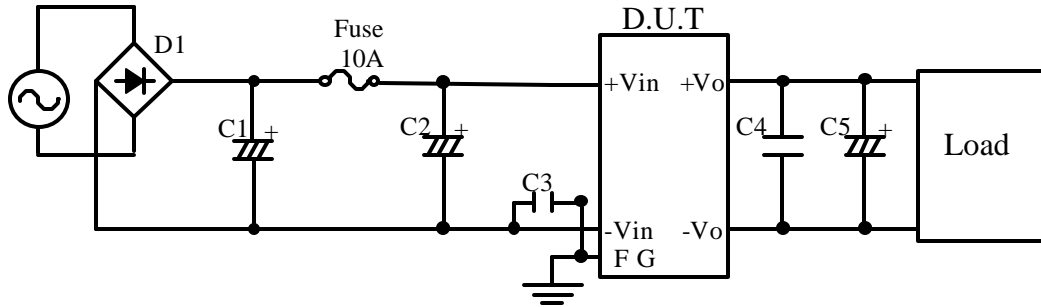

(1) Test Condition and Circuit

Input Voltage	76VDC	Output Current	30A(100%)
Base-Plate Temperature	25°C	Additional Fuse	10A
Bridge Rectifier (D1)	D10XB60H	Electrolytic Cap. (C1)	200V 1000uF x 10pcs
Electrolytic Cap. (C2)	100V 33uF	Ceramic Cap. (C3)	AC400V 4700pF
Ceramic Cap. (C4)	50V 1uF	Electrolytic Cap. (C5)	10V 2200uF

(2) Test Results

No.	Test Position		Test Mode		Test Results													
	Location No.	Test Point	S H O R T	O P E N	1	2	3	4	5	6	7	8	9	10	11	12	Note	
					F I R E	S M O K E	B U R S T	S M E L L	R E D H O T	D A M A G E	F U S E B L O W	O. C. P.	O. V. P.	N O O U T P U T	N O C H A N G E	O T H E R		
1	Q1	D-G	●							●				●			Q1, R27, A1 Damage	
2		D-S	●							●				●			R30, Q1, A1 Damage	
3		G-S	●											●				
4		D		●											●			
5		S			●										●			
6		G			●										●			
7	Q2	E-B	●													●		
8		E-C	●											●				
9		B-C	●											●				
10		B			●											●		
11		C			●											●		
12		E			●											●		

No.	Test Position		Test Mode		Test Results												Note
	Location No.	Test Point	S H O R T	O P E N	1	2	3	4	5	6	7	8	9	10	11	12	
					F I R E	S M O K E	B U R S T	S M E L L	R E D H O T	D A M A G E	F U S E B L O W	O. C. P.	O. V. P.	N O O U T P U T	N O C H A N G E	O T H E R	
13	D1		●							●	●			●			Q101, Q102, A2 Damage
14				●											●		Efficiency Low
15	D2		●												●		
16				●										●			
17	D3		●											●			
18				●										●			
19	D4		●												●		
20				●										●			
21	D6		●												●		
22				●											●		
23	ZD1		●												●		Efficiency Low
24				●											●		
25	ZD2		●													●	Output Low
26				●											●		
27	ZD3		●											●			
28				●											●		
29	PC1	1-3	●										●				
30		4-6	●											●			
31		1		●									●				
32		3		●									●				
33		4		●									●				
34		6		●									●				
35	PC2	1-3	●												●		
36		4-6	●										●				
37		1		●											●		
38		3		●											●		
39		4		●											●		
40		6		●											●		
41	C4		●													●	Output High
42				●									●	●			
43	C5		●												●		
44				●											●		
45	C9		●											●			
46				●										●			
47	C12		●											●			
48				●										●			
49	C18		●											●			
50				●											●		



No.	Test Position		Test Mode		Test Results												Note
	Location No.	Test Point	S H O R T	O P E N	1	2	3	4	5	6	7	8	9	10	11	12	
					F I R E	S M O K E	B U R S T	S M E L L	R E D H O T	D A M A G E	F U S E B L O W	O. C. P.	O. V. P.	N O O U T P U T	N O O C H A N G E	O T H E R	
51	T1	1-3	●											●			
52		6-7	●											●			
53		1		●										●			
54		3		●										●			
55		6		●										●			
56		7		●										●			
57		Q101	D-G	●									●				
58	D-S		●									●					
59	G-S		●												●		Efficiency Low
60	D			●											●		Efficiency Low
61	S			●											●		Efficiency Low
62	G			●											●		Efficiency Low
63	Q102	D-G	●						●	●				●			Q102 Damage
64		D-S	●								●			●			
65		G-S	●											●			
66		D		●										●			
67		S		●										●			
68		G		●										●			
69	D101		●													●	Output Low
70				●												●	Output Low
71	D102		●													●	Output Low
72				●												●	Output Low
73	ZD101		●											●			
74				●											●		
75	C102		●								●			●			
76				●												●	Output Drop To Zero
77	C103		●											●			Efficiency Low
78				●											●		Efficiency Low
79	C105		●						●					●			R103, R104, R107 Damage
80				●											●		

No.	Test Position		Test Mode		Test Results												Note			
	Location No.	Test Point	S H O R T	O P E N	1	2	3	4	5	6	7	8	9	10	11	12				
					F I R E	S M O K E	B U R S T	S M E L L	R E D H O T	D A M A G E	F U S E B L O W	O. C. P.	O. V. P.	N O O U T P U T	N O O C H A N G E	O T H E R				
81	T101	1-2	●													●	Output Low			
82		3-4	●														●	Output Low		
83		1		●														●	Output Low	
84		2		●															●	Output Low
85		3		●															●	Output Low
86		4		●															●	Output Low
87		T102	1-2	●														●	Output Low	
88	3-4		●														●	Output Low		
89	1		●															●	Output Low	
90	2			●															●	Output Low
91	3			●															●	Output Low
92	4			●															●	Output Low
93	Reverse Input Voltage											●		●						

## 5. Vibration Test

**MODEL : PAH150S48-5**

### (1) Vibration Test Class

Frequency Variable Endurance Test

### (2) Equipment Used

Controller : F-400-BM-DCS-7800 (EMIC CORP.)

Vibrator : 905-FN (EMIC CORP.)

### (3) Test Conditions

Sweep Frequency : 10-55Hz

Sweep Time : 1 min.

Amplitude : (0.825mm) const.

Direction : X, Y, Z

Test Time : 1 hour each

### (5) Test Method

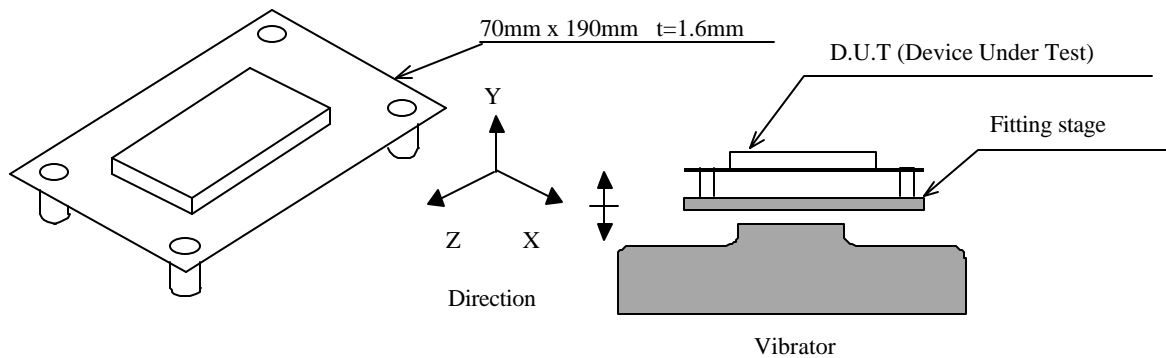

Put the D.U.T. on the universal circuit board (soldering Input Output signal terminals and fixing by four M3-tapped-holes) and fit it on the fitting-stage.

### (6) Test Results

Check Item		Output Voltage (V)	Ripple Voltage (mVp-p)	D.U.T. State
Before Test		5.007	42	OK
After Test	X	5.005	42	OK
	Y	5.004	42	OK
	Z	5.004	42	OK

## 6. High Temperature Storage Test

**(1) Equipment Used**

TEMPERATURE CHAMBER PL-2G (Tabai)

**(2) Model**

PAH150S48-5

**(3) The Number Of D.U.T. (Device Under Test)**

3 Units

**(4) Test Conditions**

Ambient Temperature : 100°C

Test Time : 96 Hours

Not Operating

**(5) Test Method**

Check if there is no abnormal output before test. Then fix the D.U.T. in testing chamber, and the chamber temperature is gradually increased from 25°C to 100°C. Leave the D.U.T. for 96 hours at 100°C and for 1 hour at the room temperature, then check if there is no abnormal output.

**(6) Test results**

Test Condition :-

Vin = 48 VDC

Load = 100%

Base-Plate temperature = 25°C

Check Items	No. 1		No.2		No.3	
	Before Test	After Test	Before Test	After Test	Before Test	After Test
Output Voltage	5.006 V	5.007 V	5.019 V	5.017 mV	5.014 V	5.014 V
Ripple Voltage	60 mV	55.9 mV	68 mV	66 mV	69.5 mV	69 mV
Line Regulation	3 mV	3 mV	2 mV	3 mV	5 mV	4 mV
Load Regulation	5 mV	6 mV	4 mV	5 mV	8 mV	6 mV
Isolation Resistance	OK	OK	OK	OK	OK	OK
Withstand Voltage	OK	OK	OK	OK	OK	OK
Appearance	OK	OK	OK	OK	OK	OK

**Final Result : OK.**

**7. Low Temperature Storage Test****(1) Equipment Used**

TEMPERATURE CHAMBER PL-2G (Tabai)

**(2) Model**

PAH150S48-5

**(3) The Number Of D.U.T. (Device Under Test)**

3 Units

**(4) Test Conditions**

Ambient Temperature : -40°C

Test Time : 96 Hours

Not Operating

**(5) Test Method**

Check if there is no abnormal output before test. Then fix the D.U.T. in testing chamber, and the chamber temperature is gradually decreased from 25°C to -40°C. Leave the D.U.T. for 96 hours at -40°C and for 1 hour at the room temperature, then check if there is no abnormal output.

**(6) Test results**

Test Conditions :-

Vin = 48 VDC

Load = 100%

Base-Plate Temperature = 25 °C

Check Items	No. 1		No.2		No. 3	
	Before Test	After Test	Before Test	After Test	Before Test	After Test
Output Voltage	5.009 V	5.006 V	5.018 V	5.019 V	5.012 V	5.014 V
Ripple Voltage	55 mV	60 mV	49.5 mV	68 mV	60 mV	69.5 mV
Line Regulation	3 mV	3 mV	3 mV	2 mV	5 mV	5 mV
Load Regulation	6 mV	5 mV	5 mV	6 mV	7 mV	8 mV
Isolation Resistance	OK	OK	OK	OK	OK	OK
Withstand Voltage	OK	OK	OK	OK	OK	OK
Appearance	OK	OK	OK	OK	OK	OK

**Final result : OK**

## 8. Resistance To Soldering Heat Test

**(1) Machine Used**

Automatic Dip Soldering Machine (OSAKA ASAHI KAGAKU)

**(2) Model**

PAH150S48-5

**(3) The Number Of D.U.T. (Device Under Test)**

1 Unit

**(4) Test Conditions**

Dip Soldering temperature : 260°C

Dip time : 10 Seconds

Pre-heating temperature : 60 Seconds

**(5) Test Method**

Check if there is no abnormal output before test. Then put the D.U.T. on a circuit board, transfer to flux-dipping, pre-heat and solder in the automatic dip soldering machine. Leave it for 1 hour at the room temperature, then check if there is no abnormal output.

**(6) Test Result**

Test Conditions :-

Vin = 48 VDC

Load = 100%

Base-Plate Temperature = 25°C

Check Items	Before Test	After Test
Output Voltage	5.0027 V	5.0027 V
Ripple Voltage	68 mV	72 mV
Line Regulation	7 mV	7 mV
Load Regulation	6 mv	7 mV
Isolation Resistance	OK	OK
Withstand Voltage	OK	OK
Appearance	OK	OK

**Final Result : OK**

## 9. Thermal Shock Test

(1) **Equipment Used**

TermalShock Chamber TSV-40 (TABAI ESPEC CORP.)

(2) **Model**

PAH150S48-5

(3) **The Number Of D.U.T. (Device Under Test)**

3 Units

(4) **Test Conditions**

- Ambient Temperature : -40°C~100°C
- Test Time : 300 Hours
- Test Cycle : 300 Cycles
- Not Operating

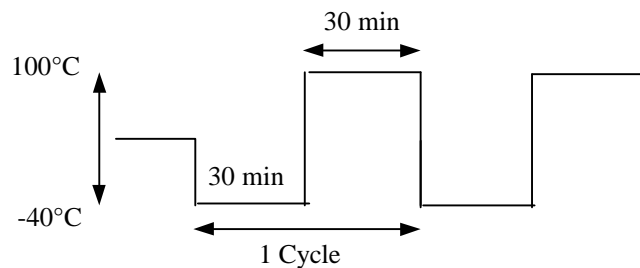

(5) **Test Method**

Before testing, check if there is no abnormal output, then put the D.U.T. in testing chamber, and test it according to the above cycle. After 300 cycles later, leave it for 1 hour at room temperature. then check if there is no abnormal output.

(6) **Test results**

**Final Result : OK.**

Refer to next page (page 14) for measuring data.

