

PH300S280 - *

RELIABILITY DATA

信頼性データ

DWG. No. C113-57-01			
承認	承認	査閲	担当
<i>S. Murayama</i>	<i>K. Watanabe</i>	<i>S. Tomioka</i>	<i>K. Satoh</i>
<i>15/OCT/97</i>	<i>4/OCT/97</i>	<i>3/Sep/97</i>	<i>3/Sep/97</i>

I N D E X

	PAGE
1. MTBF 計算値 Calculated Values of MTBF	R-1
2. 部品ディレーティング Component Derating	R-2
3. 主要部品温度上昇値 Main Components Temperature Rise ΔT List	R-4
4. アブノーマル試験 Abnormal Test	R-5
5. 振動試験 Vibration Test	R-9
6. ノイズシミュレート試験 Noise Simulate Test	R-10
7. はんだ耐熱性試験 Resistance to Soldering Heat Test	R-11
8. 熱衝撃試験 Thermal Shock Test	R-12
9. 高温貯蔵試験 High Temperature Storage Test	R-14
10. 低温貯蔵試験 Low Temperature Storage Test	R-15

※ 信頼性試験は、代表データであり、全ての製品は、ほぼ同等な特性を示します。
従いまして、この値は実力値とお考え願います。

The following data are typical values. As all units have nearly the same characteristics, the data to be considered as ability values.

1. MTBF計算値 Calculated Values of MTBF

MODEL : PH300S280-5

(1) 算出方法 Calculating Method

EIAJ (RCR-9102)の部品点数法で算出されています。

それぞれの部品ごとに、部品故障率 λ_G が与えられ、各々の点数によって決定されます。

Calculated based on part count reliability projection of EIAJ (RCR-9102). Individual failure rate λ_G is given to each part, and MTBF is calculated by the count of each part.

<算出式>

$$MTBF = \frac{1}{\lambda_{equip}} = \frac{1}{\sum_{i=1}^n N_i (\lambda_G \pi_Q)_i} \times 10^6 \text{ 時間(Hours)}$$

λ_{equip} : 全機器故障率 (故障数/10⁶時間)
Total Equipment Failure Rate (Failure/10⁶ Hours)

λ_G : i 番目の同属部品に対する故障率 (故障数/10⁶時間)
Generic Failure Rate for The i th Generic Part (Failure/10⁶ Hours)

N : i 番目の同属部品の個数
Quantity of i th Generic Part

n : 異なった同属部品のカテゴリーの数
Number of Different Generic Part Categories

π_Q : i 番目の同属部品に対する品質ファクタ ($\pi_Q=1$)
Generic Quality Factor for The i th Generic Part ($\pi_Q=1$)

(2) MTBF値 MTBF Values

G_F : 地上固定 (GROUND, FIXED)

MTBF ≒ 325,934 時間 (Hours)

2. 部品ディレーティング Component Derating

MODEL : PH300S280-5

(1) 算出方法 Calculating Method

(a) 測定条件 Measuring Conditions

- ・入力電圧 : 280VDC
Input Voltage
- ・出力電流 : 50A (100%)
Output Current
- ・取付方法 : 標準取付 (放熱器有)
Mounting Method Standard Mounting Method (with Heatsink)
- ・ベースプレート温度 : 100°C
Base-Plate Temperature

(b) 半導体 Semiconductors

ケース温度、消費電力および熱抵抗より使用状態の接合点温度を求め、最大定格との比較を行いました。

The maximum rating temperature is compared with junction temperature which is calculated based on case temperature, power dissipation and thermal impedance.

(c) IC、抵抗、コンデンサー等 IC, Resistors, Capacitors, etc.

周囲温度、使用状態、消費電力など、個々の値は設計基準内に入っています。

Ambient temperature, operating condition, power dissipation, etc are within derating criteria.

(d) 熱抵抗算出方法 Calculating Method of Thermal Impedance

$$\theta_{j-c} = \frac{T_{j(max)} - T_c}{P_{c(max)}} \quad \theta_{j-a} = \frac{T_{j(max)} - T_a}{P_{c(max)}} \quad \theta_{j-l} = \frac{T_{j(max)} - T_l}{P_{c(max)}}$$

T_c : ディレーティングの始まるケース温度 一般に25°C
Case Temperature at Start Point of Derating ; 25°C in General

T_a : ディレーティングの始まる周囲温度 一般に25°C
Ambient Temperature at Start Point of Derating ; 25°C in General

T_l : ディレーティングの始まるリード温度 一般に25°C
Lead Temperature at Start Point of Derating ; 25°C in General

$P_{c(max)}$: 最大コレクタ(チャネル)損失
($P_{ch(max)}$) Maximum Collector(Channel) Dissipation

$T_{j(max)}$: 最大接合点温度
($T_{ch(max)}$) Maximum Junction(Channel) Temperature

θ_{j-c} : 接合点からケースまでの熱抵抗
(θ_{ch-c}) Thermal Impedance between Junction(Channel) and Case

θ_{j-a} : 接合点から周囲までの熱抵抗
Thermal Impedance between Junction and Air

θ_{j-l} : 接合点からリードまでの熱抵抗
Thermal Impedance between Junction and Lead

(2) 部品デレーティング表 Component Derating List

部品番号 Location No.	部品名 Part Name	最大定格 MAX Rating	使用状態 Actual Rating	デレーティング率 Derating Factor	備考 Note
Q101	CHIP MOS FET	Tch(max):150°C	Tch : 111.7°C	74.5%	
O104	CHIP MOS FET	Tch(max):150°C	Tch : 108.1°C	72.1%	
Q1	CHIP MOS FET	Tch(max):150°C	Tch : 106.6°C	71.1%	
Q2	CHIP MOS FET	Tch(max):150°C	Tch : 94.6°C	63.1%	
Q3	CHIP TRANSISTOR	Tj (max):150°C	Tj : 102.8°C	68.5%	
Q4	CHIP TRANSISTOR	Tj (max):150°C	Tj : 103.8°C	69.2%	
Q5	CHIP TRANSISTOR	Tj (max):150°C	Tj : 107.5°C	71.7%	
Q6	CHIP TRANSISTOR	Tj (max):150°C	Tj : 96.5°C	64.3%	
D105	CHIP SBD	Tj (max):150°C	Tj : 116.9°C	77.9%	
D107	CHIP SBD	Tj (max):150°C	Tj : 124.2°C	82.8%	
D2	CHIP FRD	Tj (max):150°C	Tj : 93.0°C	62.0%	
D4	CHIP FRD	Tj (max):150°C	Tj : 88.0°C	58.7%	
D5	CHIP SBD	Tj (max):125°C	Tj : 91.9°C	73.5%	
PC2	CHIP COUPLER	Tj (max):125°C	Tj : 88.1°C	70.5%	
A1	CHIP IC	Tch(max):150°C	Tch : 104.4°C	69.6%	

3. 主要部品温度上昇値

Main Components Temperature Rise ΔT List

MODEL : PH300S280-5

部品番号 Location No.	部品名 Part Name	温度上昇値 ΔT_{C-P} Temperature Rise(°C)
Q101	CHIP MOS FET	5.4
Q104	CHIP MOS FET	0.7
D105	CHIP SBD	10.1
D107	CHIP SBD	13.0
T101	TRANS.,PULSE	13.8
T102	TRANS.,PULSE	17.8
A1	CHIP IC	1.0
T1	TRANS.,PULSE	4.0
	BASE-PLATE	0 (basis)

測定条件 Measuring Conditions

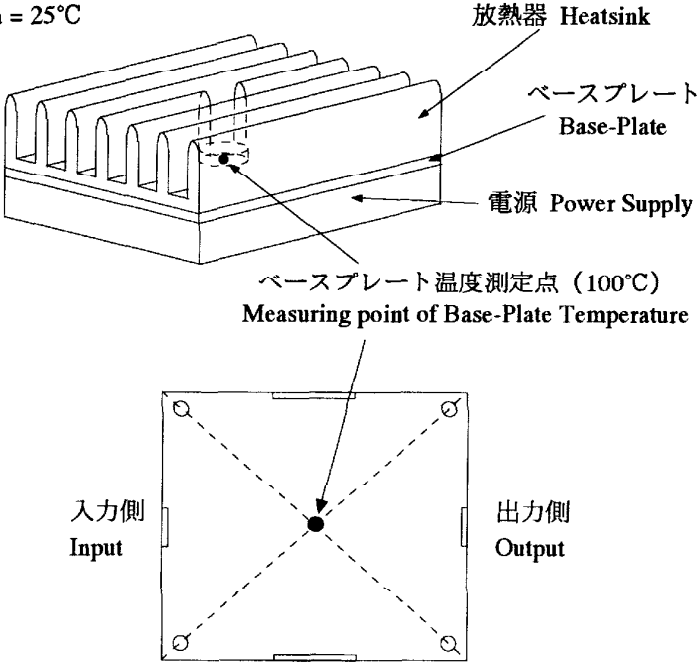
取付方法 Mounting Method	標準取付 (放熱器有) Standard Mounting Method (with Heatsink) $T_a = 25^\circ\text{C}$ 
入力電圧 Input Voltage	280VDC
出力電圧 Output Voltage	5VDC
出力電流 Output Current	50A (100%)

ΔT_{C-P} : 周囲温度 25°C においてベースプレート温度が 100°C となる放熱器を装着し、その時のベースプレート温度を基準とした各部品の ΔT (ベースプレートと部品との温度差) を表したものを。

Differential temperature between a case of each component and base-plate, fitted power supply with heatsink to be maintained 100°C (base-plate temperature) at 25°C (ambient temperature).

4. アブノーマル試験 Abnormal Test

MODEL : PH300S280-5

(1) 試験条件及び回路 Test Condition and Circuit

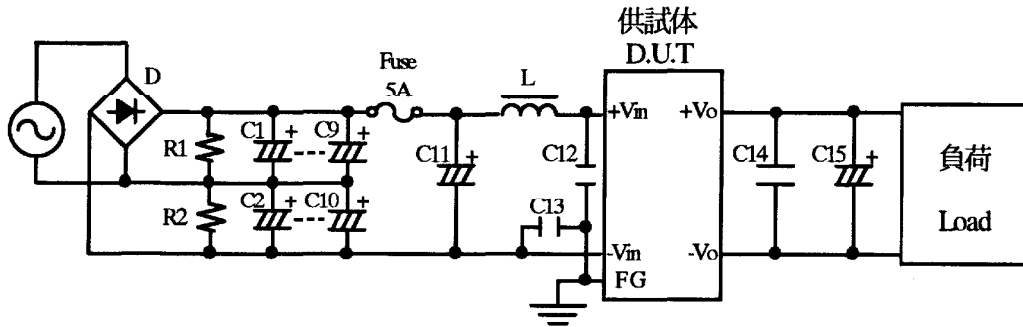

- ・入力電圧 : 400VDC
- Input Voltage
- ・ベースプレート温度 : 25°C
- Base-Plate Temperature
- ・ブリッジダイオード (D) : PGH758A
- Bridge Rectifier
- ・電解コンデンサ (C11) : 400V 22 μ F
- Electrolytic Cap.
- ・セラミックコンデンサ (C14) : 50V 2.2 μ F
- Ceramic Cap.
- ・チョークコイル (L) : 15 μ H
- Choke Coil
- ・出力電流 : 50A(100%)
- Output Current
- ・使用ヒューズ : 5A
- Additional Fuse
- ・電解コンデンサ (C1-10) : 400V 470 μ F
- Electrolytic Cap.
- ・セラミックコンデンサ (C12,13) : 400V 4700pF
- Ceramic Cap.
- ・電解コンデンサ (C15) : 10V 3900 μ F
- Electrolytic Cap.
- ・抵抗 (R1,R2) : 82k Ω
- Resistor

(2) 試験結果 Test Results

No.	試験箇所 Test Position		試験 モード Test Mode	試験結果 Test Results												備考 Note	
				Fi:Fire		So:Smoke		Bu:Burst		Se:Smell		Re:Red Hot					
	1	2	3	4	5	6	7	8	9	10	11	12	Da:Damaged	Fu:Fuse Blown	NO:No Output		NC:No Change
	部品 Location No.	試験端子 Test Point	S H O R T	O P E N	発 火 Fi	発 煙 So	破 裂 Bu	異 臭 Se	発 熱 Re	破 損 Da	ヒ ュー ズ 断 Fu	O V P	O C P	出 力 断 NO	変 化 な し NC	そ の 他 Ot	
1	O101	G		●							●	●					Da:Q101
2		S		●												●	効率低下 (Efficiency Down)
3		D		●												●	効率低下 (Efficiency Down)
4		D-S	●								●			●			
5		G-S	●											●			
6		D-G	●							●	●			●			Da:Q101

No.	試験箇所 Test Position		試験モード Test Mode		試験結果 Test Results												備考 Note			
	部品 Location No.	試験端子 Test Point	S H O R T	O P E N	Fi:Fire			So:Smoke			Bu:Burst		Se:Smell		Re:Red Hot					
					Da:Damaged	Fu:Fuse Blown	NO:No Output	NC:No Change	Ot:Others	1	2	3	4	5	6	7		8	9	10
7	Q104	G		●																
8		S		●																
9		D		●																
10		D-S	●																	
11		G-S	●								●									Da:A3
12		D-G	●																	
13	Q1	G		●																
14		S		●																
15		D		●																
16		D-S	●																	
17		G-S	●																	
18		D-G	●																	
19	Q2	G		●																
20		S		●						●	●								Da:D101,Q101	
21		D		●						●	●								Da:D101,Q101	
22		D-S	●							●	●								Da:D101,Q101,Q5,Q6 A3,A4	
23		G-S	●																	
24		D-G	●																	
25	Q3	E		●														●	効率低下 (Efficiency Down)	
26		C		●														●	効率低下 (Efficiency Down)	
27		B		●														●	効率低下 (Efficiency Down)	
28		B-E	●																●	効率低下 (Efficiency Down)
29		C-E	●																	
30		B-C	●																	
31	Q4	E		●						●	●								Da:Q101,D101	
32		C		●						●	●								Da:Q101,D101	
33		B		●						●	●								Da:Q101,D101	
34		B-E	●							●	●									Da:Q101,D101
35		C-E	●																	
36		B-C	●																	

No.	試験箇所 Test Position		試験モード Test Mode		試験結果 Test Results												備考 Note	
	部品 Location No.	試験端子 Test Point	S H O R T	O P E N	Fi:Fire Da:Damaged			So:Smoke Fu:Fuse Blown			Bu:Burst NO:No Output			Se:Smell NC:No Change		Re:Red Hot Ot:Others		
					1	2	3	4	5	6	7	8	9	10	11	12		
					発 火 Fi	発 煙 So	破 裂 Bu	異 臭 Se	発 熱 Re	破 損 Da	ヒ ュ ー ズ 断 Fu	○ V P	○ C P	出 力 断 NO	変 化 な し NC	そ の 他 Ot		
37	Q5	E		●												●		
38		C		●												●		
39		B		●												●		
40		B-E	●														●	
41		C-E	●															● 出力電圧低下 (Output Voltage Down)
42	Q6	B-C	●											●				
43		E		●						●	●			●			Da:Q101,D101	
44		C		●											●			
45		B		●						●	●			●			Da:Q101,D101	
46		B-E	●												●			
47		C-E	●											●				
48	B-C	●							●	●			●			Da:D101,Q101,L102,Q5,Q6 Λ3,Λ4		
49	D1			●											●			
50			●							●				●			Da:A1	
51	D3			●										●				
52			●												●			
53	D4			●										●				
54			●											●				
55	D5			●										●				
56			●											●				
57	D104			●												●	効率低下 (Efficiency Down)	
58			●											●				
59	D106			●												●	効率低下 (Efficiency Down)	
60			●											●				
61	Z1			●											●			
62			●											●				
63	Z2			●										●				
64			●											●				
65	A1	C		●										●				
66		D		●										●				
67		S		●										●				
68		C-D	●							●				●			Da:T1,A1,Q5,R4	
69		C-S	●											●				
70	D-S	●							●				●			Da:T1		
71	C4			●										●				
72			●												●			

No.	試験箇所 Test Position		試験モード Test Mode		試験結果 Test Results												備考 Note
	部品 Location No.	試験端子 Test Point	S H O R T	O P E N	Fi:Fire Da:Damaged			So:Smoke Fu:Fuse Blown			Bu:Burst NO:No Output		Se:Smell NC:No Change		Re:Red Hot Ot:Others		
					1	2	3	4	5	6	7	8	9	10	11	12	
73	C10			●											●		
74			●												●		
75	C31			●											●		
76			●							●							Da:R56,R57
77	C32			●											●		
78			●							●							Da:R62,R63
79	C33			●											●		
80			●							●							Da:R64,65
81	C44			●											●		
82			●							●							Da:J1,J2
83	C101			●											●		
84			●								●			●			
85	C105			●										●			
86			●												●		
87	C107			●											●		
88			●										●				
89	T1	1		●										●			
90		7		●										●			
91		1-4	●							●				●			Da:A1
92		5-7	●							●				●			Da:A1
93	T101	1		●										●			
94		3		●										●			
95		1-2	●													●	効率低下 (Efficiency Down)
96		3-4	●											●			
97	T102	1		●										●			
98		3		●									●				
99		1-2	●											●			
100		3-4	●											●			
101	入力逆接続 Inverse Input Connection									●	●			●			Da:Q101,Q102,A1

5. 振動試験 Vibration Test

MODEL : PH300S280-3.3

(1) 振動試験種類 Vibration Test Class

掃引振動数耐久試験 Frequency Variable Endurance Test

(2) 使用振動試験装置 Equipment Used

EMIC (株)製
EMIC CORP.制御部 F-400-BM-DCS-7800
Controller加振部 905-FN
Vibrator

(3) 供試品台数 The Number of D.U.T. (Device Under Test)

1台 (unit)

(4) 試験条件 Test Conditions

- ・ 周波数範囲 Sweep Frequency 10~55Hz
- ・ 掃引時間 Sweep Time 1 分間 1 min.
- ・ 振幅 Amplitude 一定 (0.825mm) const.
- ・ 振幅方向 Direction X, Y, Z
- ・ 試験時間 Test Time 1 時間 1 hour each

(5) 試験方法 Test Method

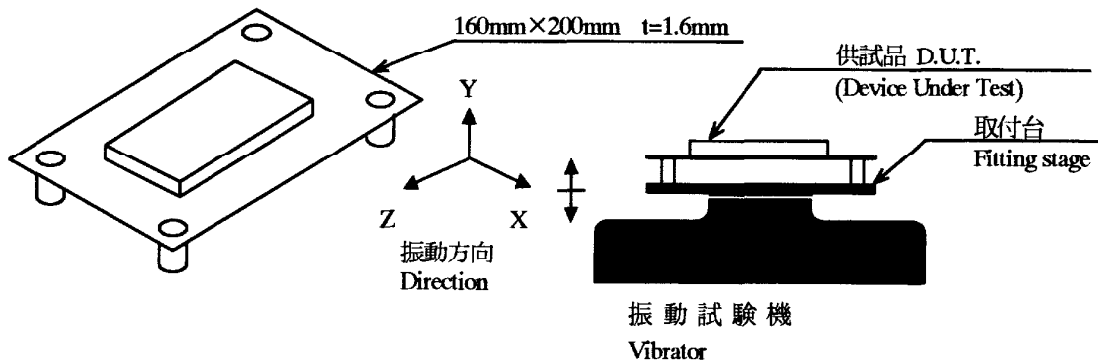

供試品を基板に取付け(はんだ付けをし、M3ピスで4箇所固定)、それを取付台に固定する。

Fix the D.U.T. on the circuit board (soldering and fitting by four M3-tapped-holes) and fit it on the fitting-stage.

(6) 試験結果 Test Results

合格 OK

・ 試験条件 Test Conditions

入力電圧 : 280VDC

出力電流 : 50A(100%)

ベースプレート温度 : 25°C

Input Voltage

Output Current

Base-Plate Temperature

測定確認項目 Check Item	出力電圧 (V) Output Voltage	リップル電圧 (mVp-p) Ripple Voltage	機構・実装状態 D.U.T. State	
試験前 Before Test	3.322	80	異常なし OK	
試験後 After Test	X	3.324	84	異常なし OK
	Y	3.323	82	異常なし OK
	Z	3.324	90	異常なし OK

6. ノイズシミュレート試験 Noise Simulate Test

MODEL : PH300S280-5

(1) 試験回路及び測定器 Test Circuit and Equipment

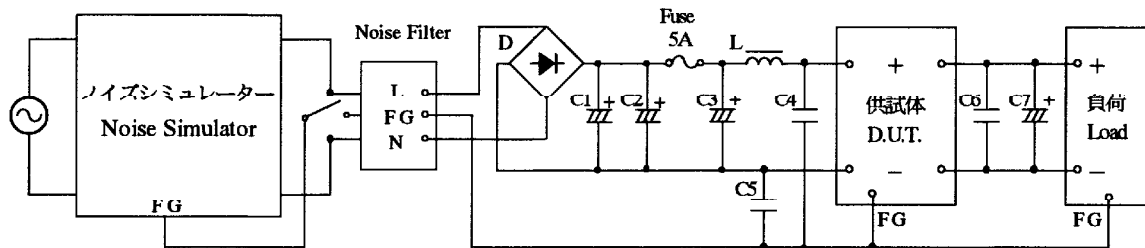

- ・ノイズシミュレーター Noise Simulator : INS-4420 (ノイズ研究所)
(Noise Laboratory Co.,LTD.)
- ・ノイズフィルター Noise Filter : MXB-1210-33 (NEMIC-LAMBDA)
- ・ブリッジダイオード (D) Bridge Rectifier : PGH758A (日本インター)
(NIHON INTER)
- ・電解コンデンサ (C1,2) Electrolytic Cap. : 400V 470 μ F
- ・電解コンデンサ (C3) Electrolytic Cap. : 400V 22 μ F
- ・セラミックコンデンサ (C4,C5) Ceramic Cap. : AC400V 4700pF
- ・セラミックコンデンサ (C6) Ceramic Cap. : 50V 2.2 μ F
- ・電解コンデンサ (C7) Electrolytic Cap. : 10V 3900 μ F
- ・チョークコイル (L) Choke Coil : 15 μ H

(2) 試験条件 Test Conditions

- | | | | |
|--------------------------------------|---------------|-----------------------|------------------------------|
| ・入力電圧
Input Voltage | : 280VDC | ・ノイズ電圧
Noise Level | : 0V~2kV |
| ・出力電圧
Output Voltage | : 5V | ・位相
Phase Shift | : 0°~360° |
| ・出力電流
Output Current | : 50A (100%) | ・極性
Polarity | : +, - |
| ・ベースプレート温度
Base-Plate Temperature | : 25°C | ・モード
Mode | : ノーマル、コモン
Normal, Common |
| ・パルス幅
Pulse Width | : 50ns~1000ns | ・トリガ
Trig Select | : ライン
Line |

(3) 判定条件 Acceptable Conditions

- | | |
|--------------|----------------------------|
| 1.破壊しない事 | Not to be broken |
| 2.出力がダウンしない事 | Not to be shut down output |
| 3.その他異常のない事 | No other out of orders |

(4) 試験結果 Test Result

合格 OK

7. はんだ耐熱性試験 Resistance to Soldering Heat Test

MODEL : PH300S280-15

(1) 使用装置 Machine Used

自動はんだ付装置 (大阪アサヒ化学)

Automatic Dip Soldering Machine (OSAKA ASAHI KAGAKU)

(2) 供試品台数 The Number of D.U.T. (Device Under Test)

1 台 (unit)

(3) 試験条件 Test Conditions

- ・ 溶融はんだ温度 : 250°C
Dip Soldering Temperature
- ・ 浸漬保持時間 : 10秒
Dip Time 10seconds
- ・ 予備加熱温度 : 120°C
Pre-heating Temperature
- ・ 予備加熱時間 : 60秒
Pre-heating Time 60seconds

(4) 試験方法 Test Method

初期測定の後、供試品を基板にのせ、自動はんだ付装置でフラックス浸漬、予備加熱、はんだ付を行う。常温常湿下に1時間放置し、出力に異常がない事を確認する。

Check if there is no abnormal output before test, then fix the D.U.T. on a circuit board, transfer to flux-dipping, pre-heat, and solder in the automatic dip soldering machine. Leave it for 1 hour at the room temperature, then check if there is no abnormal output.

(5) 試験結果 Test Results

合格 OK

・ 試験条件 Test Conditions

入力電圧 : 280VDC

出力電流 : 20A(100%)

ベースプレート温度 : 25°C

Input Voltage

Output Current

Base-Plate Temperature

測定確認項目 Check Item		試験前 Before Test	試験後 After Test
出力電圧 Output Voltage	V	15.094	15.090
リップル電圧 Ripple Voltage	mVp-p	76	76
入力変動 Line Regulation	mV	4	4
負荷変動 Load Regulation	mV	19	19
絶縁抵抗 Isolation Resistance	-	異常なし OK	異常なし OK
耐電圧 Withstand Voltage	-	異常なし OK	異常なし OK
外観 Appearance	-	異常なし OK	異常なし OK

8. 熱衝撃試験 Thermal Shock Test

MODEL : PH300S280-5

(1) 使用計測器 Equipment Used

THERMAL SHOCK CHAMBER TSV-40 (TABAI ESPEC CORP.)

(2) 供試品台数 The Number of D.U.T. (Device Under Test)

5 台 (units)

(3) 試験条件 Test Conditions

- ・電源周囲温度 : $-40^{\circ}\text{C} \longleftrightarrow +100^{\circ}\text{C}$
Ambient Temperature
- ・試験時間 :
Test Time

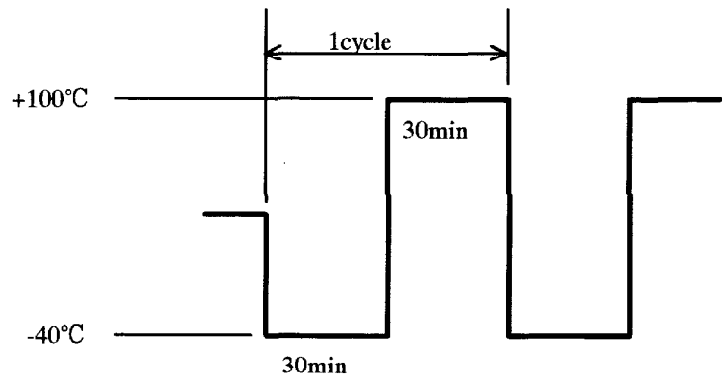

- ・試験サイクル : 100、200 サイクル
Test Cycle 100,200 cycles
- ・非動作
Not Operating

(4) 試験方法 Test Method

初期測定の後、供試品を試験槽に入れ、上記サイクルで試験を行う。100、200サイクル後に、供試品を常温常湿下に1時間放置し、出力に異常がない事を確認する。

Before the test check if there is no abnormal output and fix the D.U.T. in the testing chamber. Then test it in the above cycles. After the test is completed leave it for 1 hour at room temperature and check it if there is no abnormal output.

(5) 試験結果 Test Results

合格 OK

測定データは、次頁に示す。

See next page for measuring data.

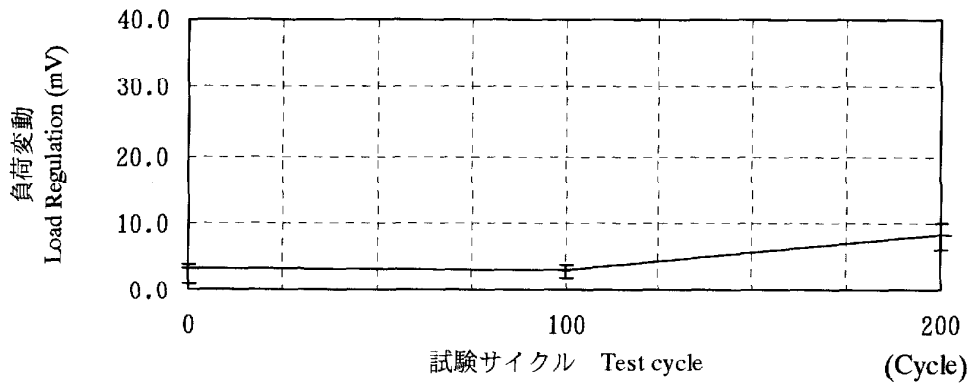
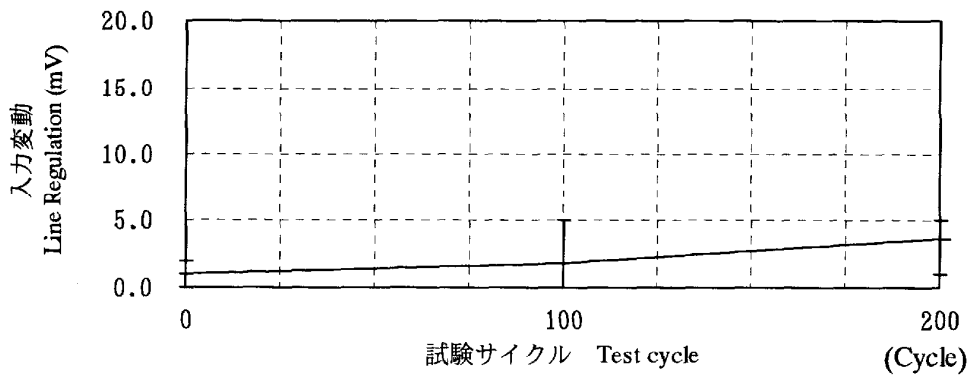
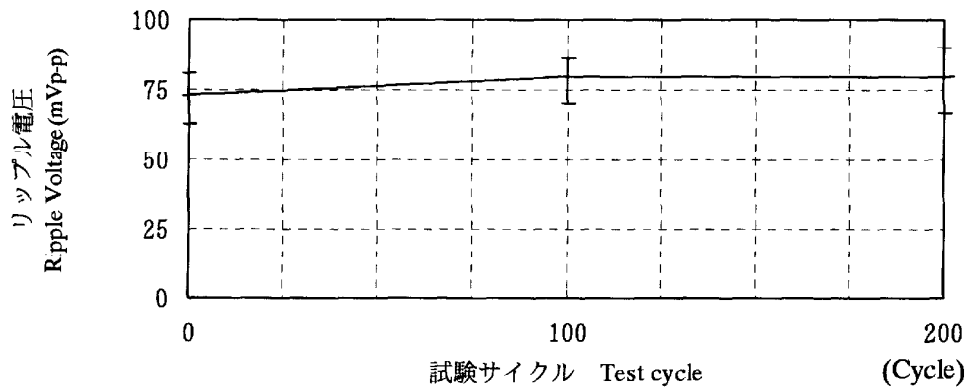
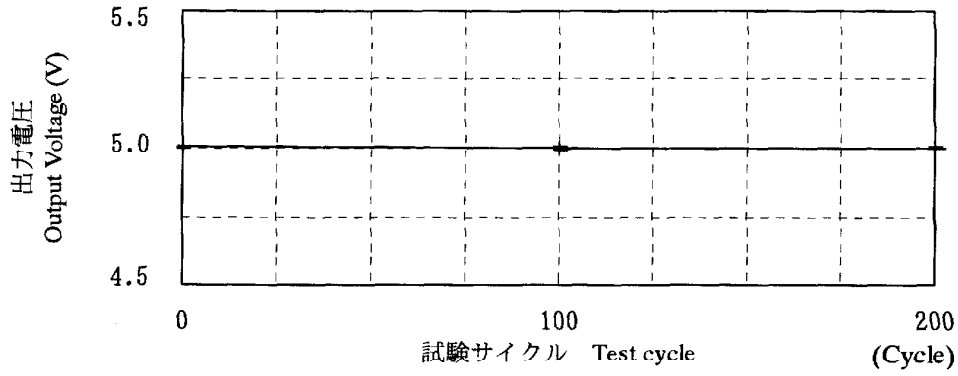

9. 高温貯蔵試験 High Temperature Storage Test

MODEL : PH300S280-5

(1) 使用計測器 Equipment Used

卓上低温恒温槽 TYPE-303D (JEC)

(2) 供試品台数 The Number of D.U.T. (Device Under Test)

3 台 (units)

(3) 試験条件 Test Conditions

・電源周囲温度 : 100°C
Ambient Temperature

・試験時間 : 96時間
Test Time Hours

・非動作
Not operating

(4) 試験方法 Test Method

初期測定の後、供試品を試験槽に入れ、槽の温度を室温 (25°C) から規定の温度 (100°C) まで徐々に上げる。供試品を規定温度で96時間放置し、常温常湿下に1時間放置した後、出力に異常がない事を確認する。

Check if there is no abnormal output before test. Then fix the D.U.T. in testing chamber, and the chamber temperature is gradually increased from 25°C to 100°C. Leave the D.U.T. for 96 hours at 100°C and for 1 hour at the room temperature, then check if there is no abnormal output.

(5) 試験結果 Test Results

合格 OK

・測定条件 Test Condition

入力電圧 : 280VDC
Input Voltage

出力電流 : 50A(100%)
Output Current

ベースプレート温度 : 25°C
Base-Plate Temperature

測定確認項目 Check Item		No. 1		No. 2		No. 3	
		試験前 Before Test	試験後 After Test	試験前 Before Test	試験後 After Test	試験前 Before Test	試験後 After Test
出力電圧 Output Voltage	V	5.042	5.045	5.006	5.009	5.022	5.029
スパイク電圧 Ripple Voltage	mVp-p	58	60	63	58	66	60
入力変動 Line Regulation	mV	1	2	2	2	1	2
負荷変動 Load Regulation	mV	7	8	6	5	5	6
絶縁抵抗 Isolation Resistance	—	異常なし OK	異常なし OK	異常なし OK	異常なし OK	異常なし OK	異常なし OK
耐電圧 Withstand Voltage	—	異常なし OK	異常なし OK	異常なし OK	異常なし OK	異常なし OK	異常なし OK
外観 Appearance	—	異常なし OK	異常なし OK	異常なし OK	異常なし OK	異常なし OK	異常なし OK

10. 低温貯蔵試験 Low Temperature Storage Test

MODEL : PH300S280-5

(1) 使用計測器 Equipment Used

TEMP. & HUMID. CHAMBER SH-240 (ESPEC CORP.)

(2) 供試品台数 The Number of D.U.T. (Device Under Test)

3 台 (units)

(3) 試験条件 Test Conditions

・電源周囲温度 : -40°C
Ambient Temperature・試験時間 : 96時間
Test Time Hours・非動作
Not operating

(4) 試験方法 Test Method

初期測定の後、供試品を試験槽に入れ、槽の温度を室温 (25°C) から規定の温度 (-40°C) まで徐々に下げる。供試品を規定温度で96時間放置し、常温常湿下に1時間放置した後、出力に異常がない事を確認する。

Check if there is no abnormal output before test. Then fix the D.U.T. in testing chamber, and the chamber temperature is gradually decreased from 25°C to -40°C. Leave the D.U.T. for 96 hours at -40°C and for 1 hour at the room temperature, then check if there is no abnormal output.

(5) 試験結果 Test Results

合格 OK

・測定条件 Test Condition

入力電圧 : 280VDC

出力電流 : 50A(100%)

ベースプレート温度 : 25°C

Input Voltage

Output Current

Base-Plate Temperature

測定確認項目 Check Item		No. 1		No. 2		No. 3	
		試験前 Before Test	試験後 After Test	試験前 Before Test	試験後 After Test	試験前 Before Test	試験後 After Test
出力電圧 Output Voltage	V	5.045	5.046	5.009	5.010	5.029	5.029
スパイク電圧 Ripple Voltage	mVp-p	60	76	58	72	60	62
入力変動 Line Regulation	mV	2	3	2	2	2	2
負荷変動 Load Regulation	mV	8	8	5	6	6	4
絶縁抵抗 Isolation Resistance	-	異常なし OK	異常なし OK	異常なし OK	異常なし OK	異常なし OK	異常なし OK
耐電圧 Withstand Voltage	-	異常なし OK	異常なし OK	異常なし OK	異常なし OK	異常なし OK	異常なし OK
外観 Appearance	-	異常なし OK	異常なし OK	異常なし OK	異常なし OK	異常なし OK	異常なし OK