

ROHS COMPLIANCE

D	CONTENTS	DATE	ENGR	CHK	APPD
	NEW RELEASE	30/04/2024	---	---	---

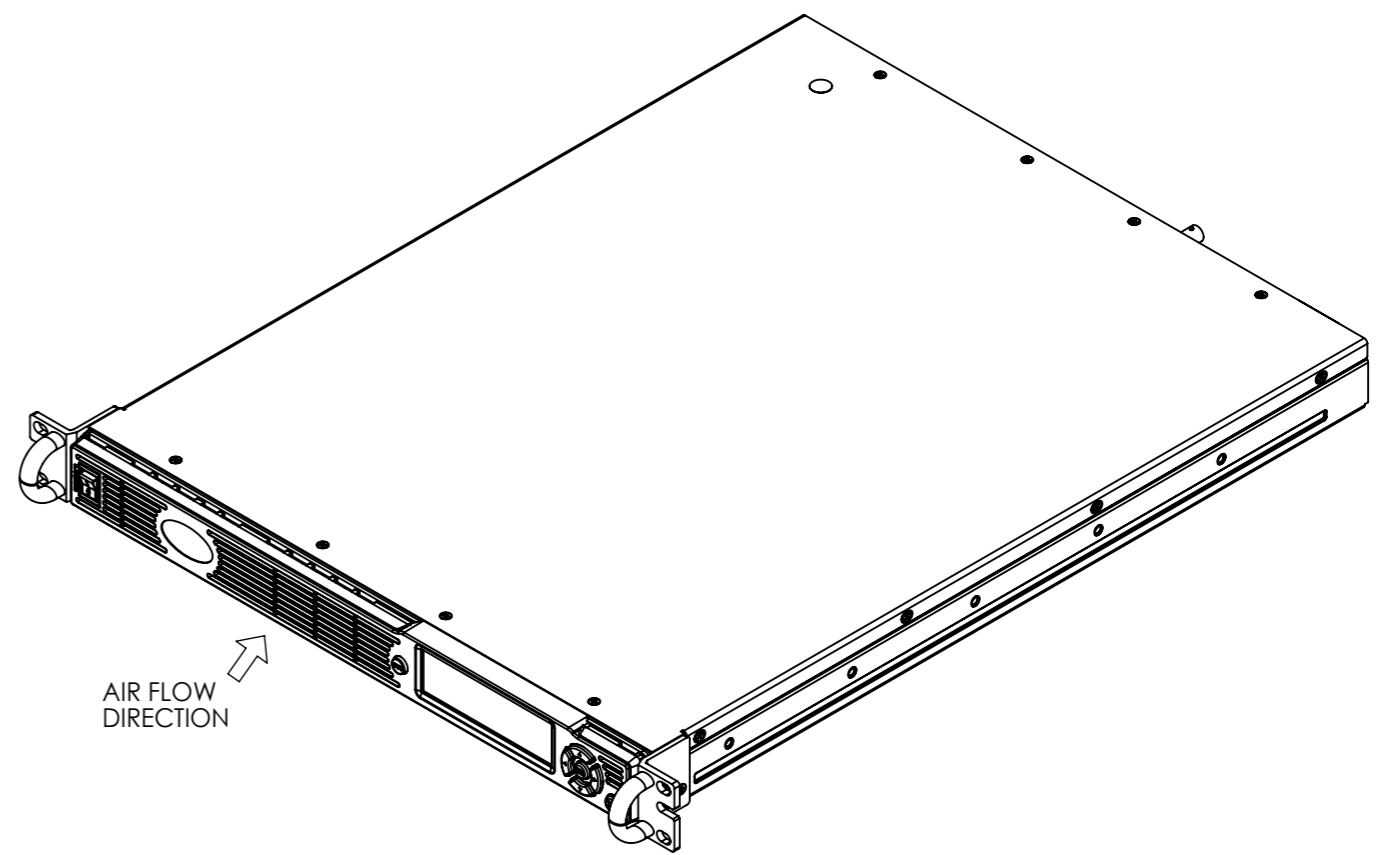
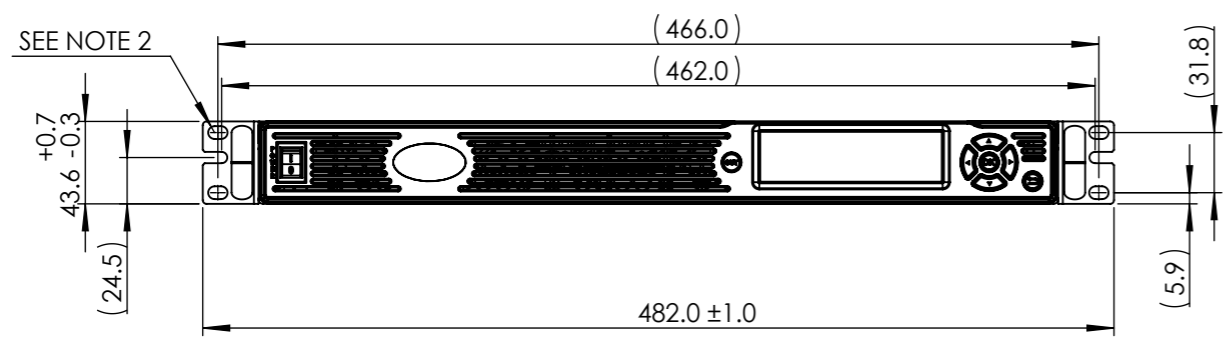
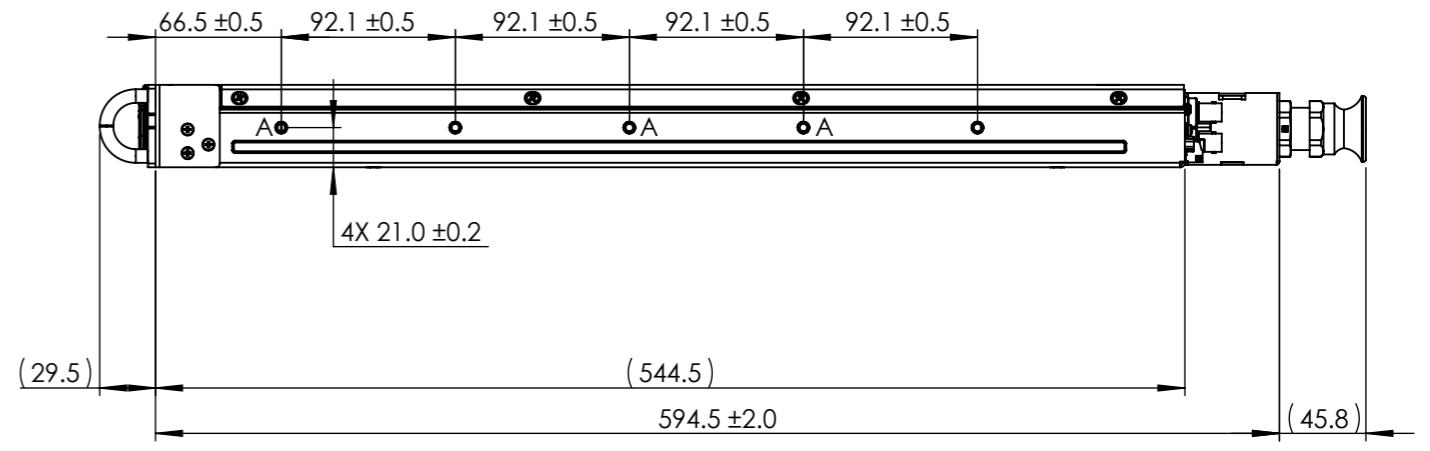
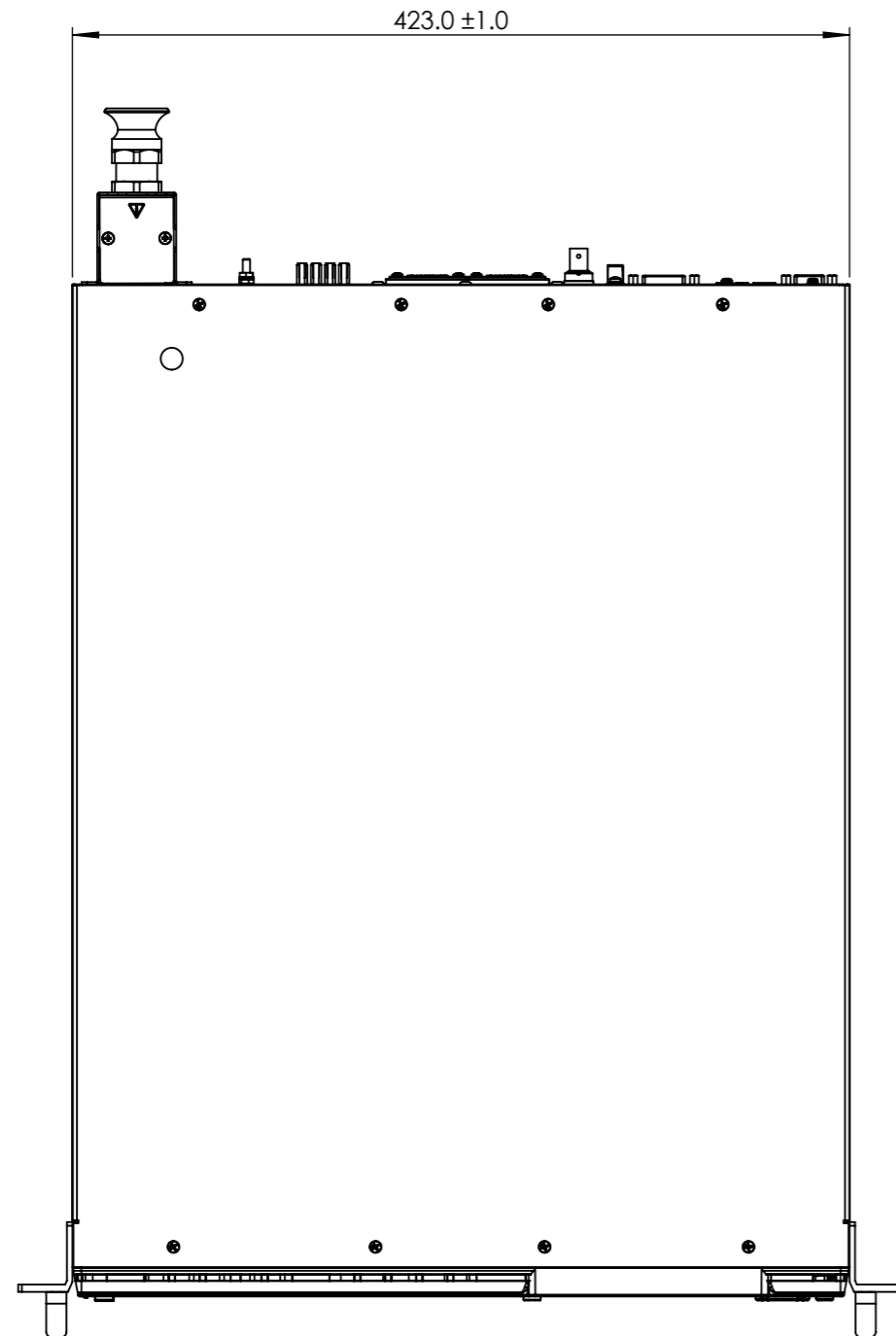

NOTE  
 1. MOUNTING HOLES FOR SLIDES P/N:CC3001-00-S160, GENERAL DEVICES OR EQUIVALENT. USE #10-32x0.375 INCH x 3 SCREWS FOR EACH SLIDE IN POSITION MARKED BY "A". ENSURE THAT THE SCREWS DO NOT PENETRATE MORE THAN 6.0mm INTO THE UNIT.  
 2. MOUNTING HOLES FOR 19" RACK, USE M6x16 SCREWS TO FIX THE UNIT TO THE RACK.  
 3. UNLESS OTHERWISE SPECIFIED, RACK DIMENSIONS COMPLIES TO EIA310 & JIS C 6010 STANDARDS.

APPD	S.MIKI	SHEET OF 1 1		MATERIALS	TITLE	<b>GAC-POWERSOURCE OUTLINE DRAWING</b>
CHK	K.ROMAN	SCALE	NONE	FINISH	DRAWING No.	
ENGR	B.MICHAEL	UNITS	mm		3RD ANGLE PROJECTION	<b>TDK-Lambda</b>