

TABLE 1

DIMENSIONS/MODEL	8V, 10V	16V-40V	60V-100V
L	60mm	40mm	40mm
L1	517.5mm	497.5mm	517.0mm

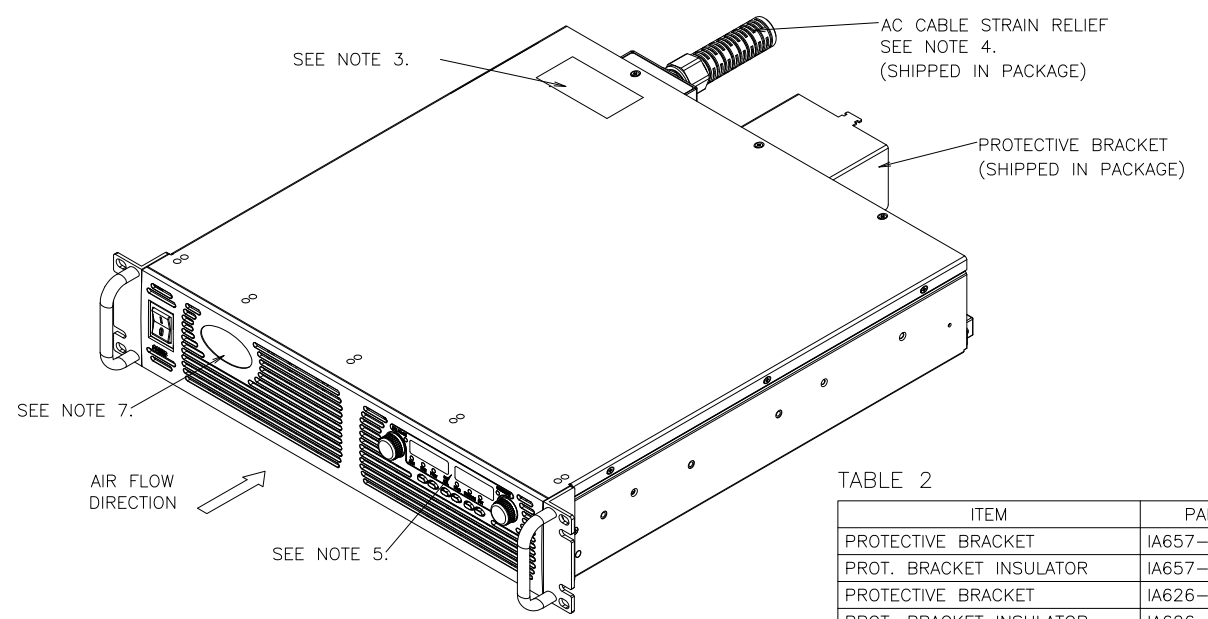
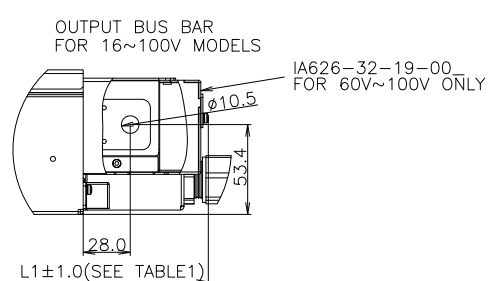
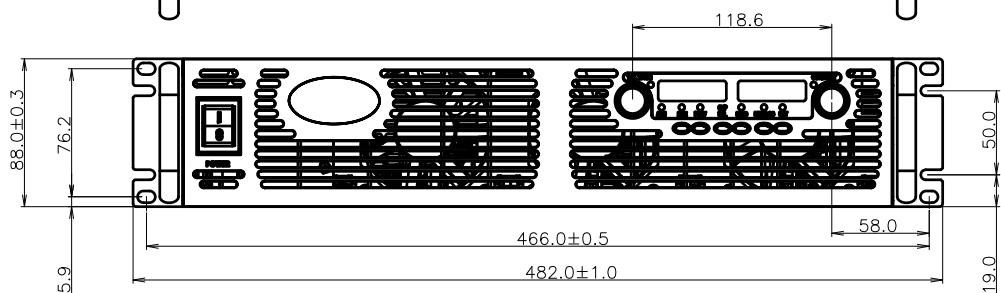
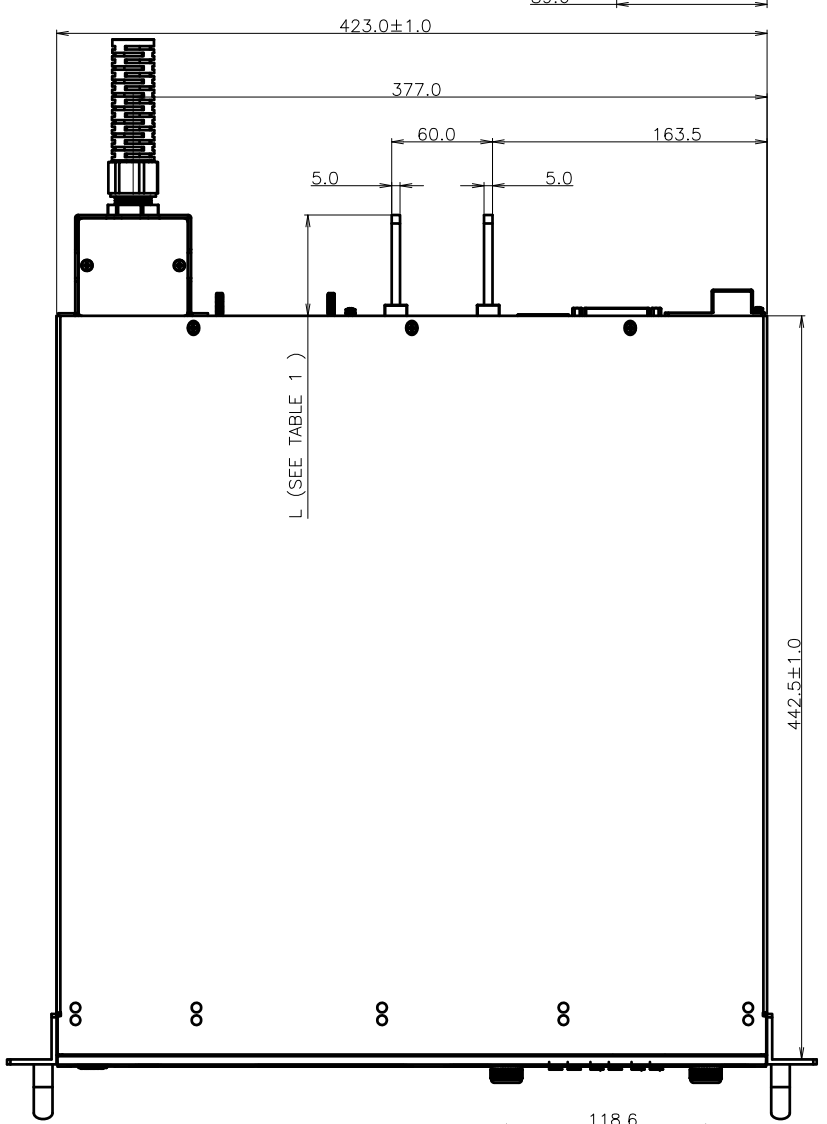

TABLE 2

ITEM	PART NUMBER	MODEL
PROTECTIVE BRACKET	IA657-32-02_	8V, 10V
PROT. BRACKET INSULATOR	IA657-33-01_	
PROTECTIVE BRACKET	IA626-32-10_	16V-100V
PROT. BRACKET INSULATOR	IA626-33-03_	
FLAT HEAD SCREW M3x8	PART NUMBER	60V-100V
PROT. BRACKET ASSEMBLY	IA626-32-19-00_	



ACCESSORIES

ITEM	PART NUMBER	QTY		PACKING	OUTER PACKING	NOTE
		8-10V	16-100V			
HEXAGONAL SCREW M10x25	DIN933 BN56	4	2	PLASTIC BAG	PLASTIC BAG	INSULATOR IS ASSEMBLED TO THE BRACKET
HEXAGONAL NUT M10	DIN439B BN124	4	2			
SPRING WASHER M10	DIN7980 BN774	4	2			
FLAT WASHER M10	DIN125A BN715	8	4			
SEMS SCREW M3x8			1	PLASTIC BAG		
PROTECTIVE BRACKET	SEE TABLE2		1	NONE		
PROT.BRACKET INSULATOR	SEE TABLE2		1			
FLAT HEAD SCREW M3x6	SEE TABLE2		3	PLASTIC BAG		
PROT.BRACKET ASSEMBLY	SEE TABLE2		1			
LINKING CABLE	IA575-81-11_		1	PLASTIC BAG		
DB25 PLUG KIT	749809-9 AMP		1	PLASTIC BAG		
INPUT CONNECTOR PLUG	PC 6/4-STF-10, 16 PHONENIX		1	NONE	PLASTIC BAG	
STRAIN RELIEF BRACKET	IA626-32-09-00_		1			
STRAIN RELIEF	1576.16.11 AGRO		1			
STRAIN RELIEF WASHER	8216 AGRO		1			
FLAT HEAD SCREW M3x8			2	PLASTIC BAG		
CASELEG	FF004-AR79 (SHINAGAWA)		4	PLASTIC BAG		

- NOTE
- MATING PLUG P/N:MC1.5/5-G-3.81 PHOENIX
 - MOUNTING HOLES FOR SLIDES P/N:CC3001-00-S160,GENERAL DEVICES OR EQUIVALENT. USE #10-32x0.38INCH x3 SCREWS FOR EACH SLIDE. ENSURE THAT THE SCREWS DO NOT PENETRATE MORE THAN 6.0mm INTO THE UNIT.
 - AC INPUT RATING AND SAFETY APPROVAL SYMBOLS ARE SHOWN HERE ACCORDING TO THE SPECIFICATIONS.
 - STRAIN RELIEF DEVICE P/N: 1576.16.11 AGRO.
 - MODEL NAME AND OUTPUT RATING ARE SHOWN HERE ACCORDING TO THE SPECIFICATIONS.
 - MOUNTING HOLES FOR 19" RACK, USE M6x16 SCREWS TO FIX THE UNIT TO THE RACK.
 - COMPANY LOGO IS SHOWN HERE.