

# **GENESYS™** Series

**Programmable DC Power Supplies**

**G1.7 - 5kW in 1U 0-600V, 0-500A**

## **PARALLEL KIT INSTRUCTION MANUAL**

**The manual covers kit options:**

**G/P-3U-10V**

**G/P-3U-20-40V**

**G/P-3U-60-100V**

**G/P-3U-150-600V**



## 1.1 General

Parallel kit is supplied separately from the power supply packing according to order.  
The usage of parallel kit is according to customer's needs.

## 1.2 Advanced Parallel

For parallel connection, refer to advanced parallel chapter in the **GENESYS™** series User Manual.

## 1.3 Product Safety Instructions

Safety approvals are valid for **GENESYS™** single unit only. These are not valid for parallel kit assembly.  
When using a paralleling kit with a protective bracket, it must be correctly assembled, as described further in this document.

## 1.4 Assembly Instructions

The supplied kit is used for standard and blank panel options. Follow the instructions carefully according to power supply model.

### 1.4.1 G/P-3U-10V - Assembly Instructions for three 10V units in Parallel

#### 1.4.1.1 Components List

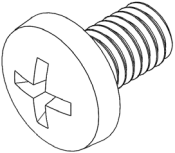

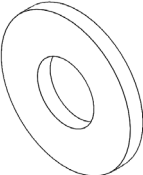
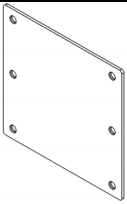

Image	Component	Quantity
	10-32 x 5/16 Pan Head Screw, Stainless Steel	12
	Helical Spring-Lock Washer, No. 10, Stainless Steel	12
	Plain Washer, No. 10, Stainless Steel	12
	Connection Plate 3U	2
	Output Short	2

Image	Component	Quantity
	M3 x 4C Flat Head Screw, Nickel Plated	8
	Paralleling Cable	2
	Output Cover	1
	Bus Bar Insulator	2
	M3 x 8 SEMS Screw, Nickel Plated	6

### 1.4.1.2 Installation Steps

1. Attach connection plates, one on each side of the power supplies, using 12 pan head screws, 12 helical spring-lock washers and 12 plain washers as illustrated in Figure 1.

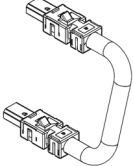
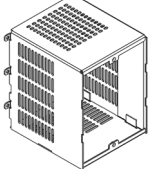
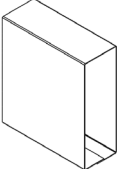
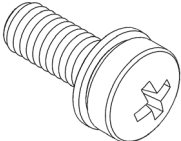
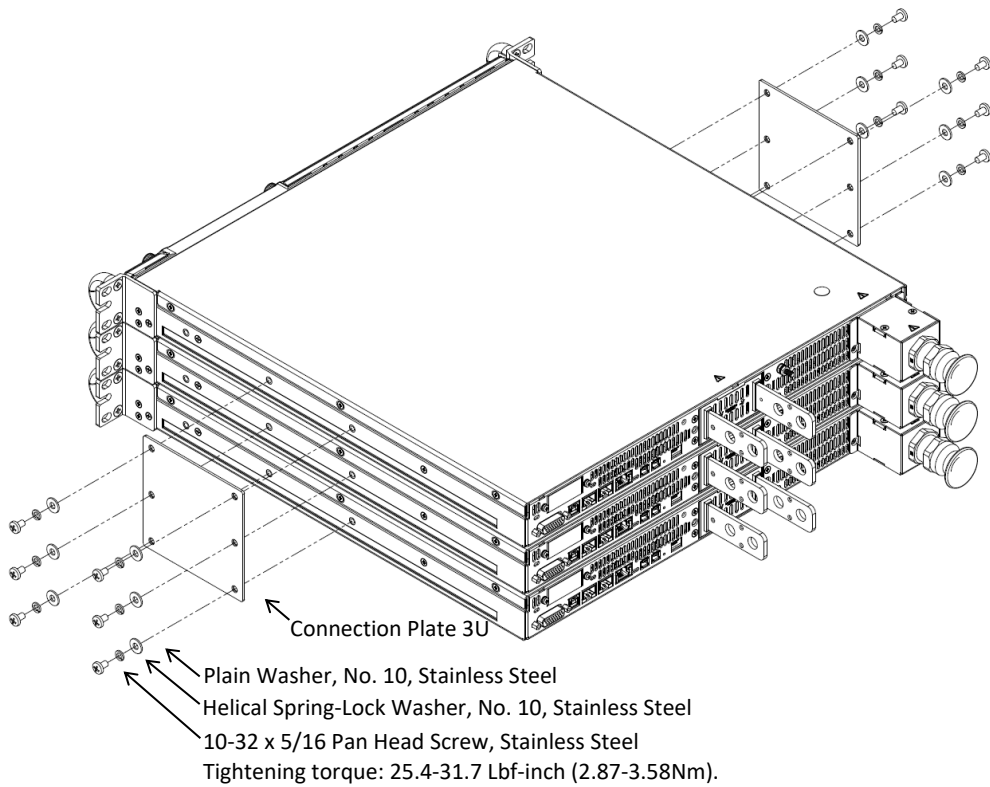

**Figure 1: Three 10V Units Connection Plates 3U Assembly**

2. Attach output short plates, one on each triple of terminals, using eight flat head screws as illustrated in Figure 2.

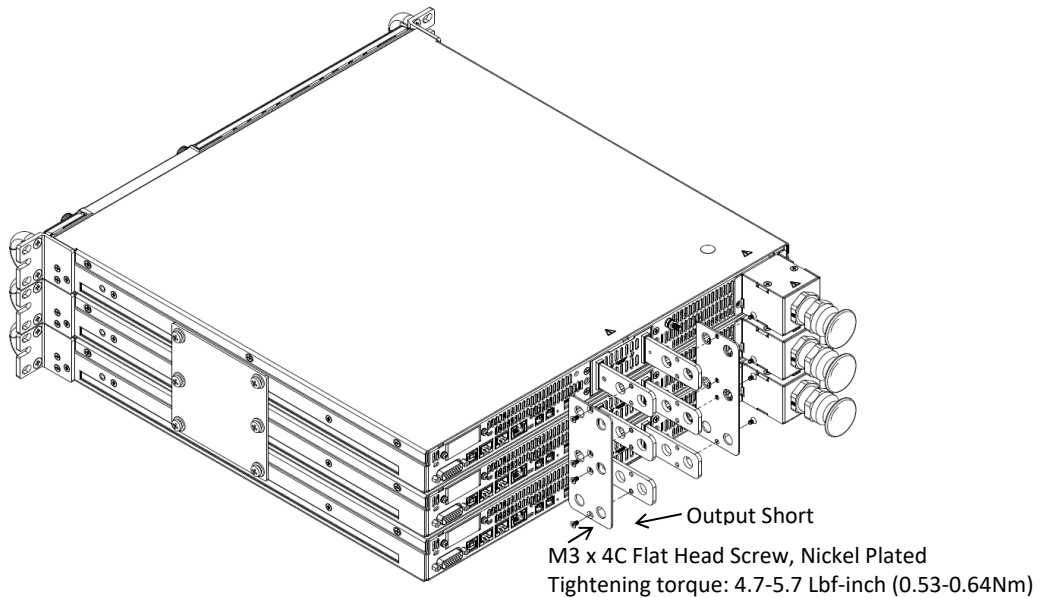

**Figure 2: Three 10V Units Output Short Plates Assembly**

3. Connect two paralleling cables from top unit M connector to bottom unit S connector as illustrated in Figure 3.

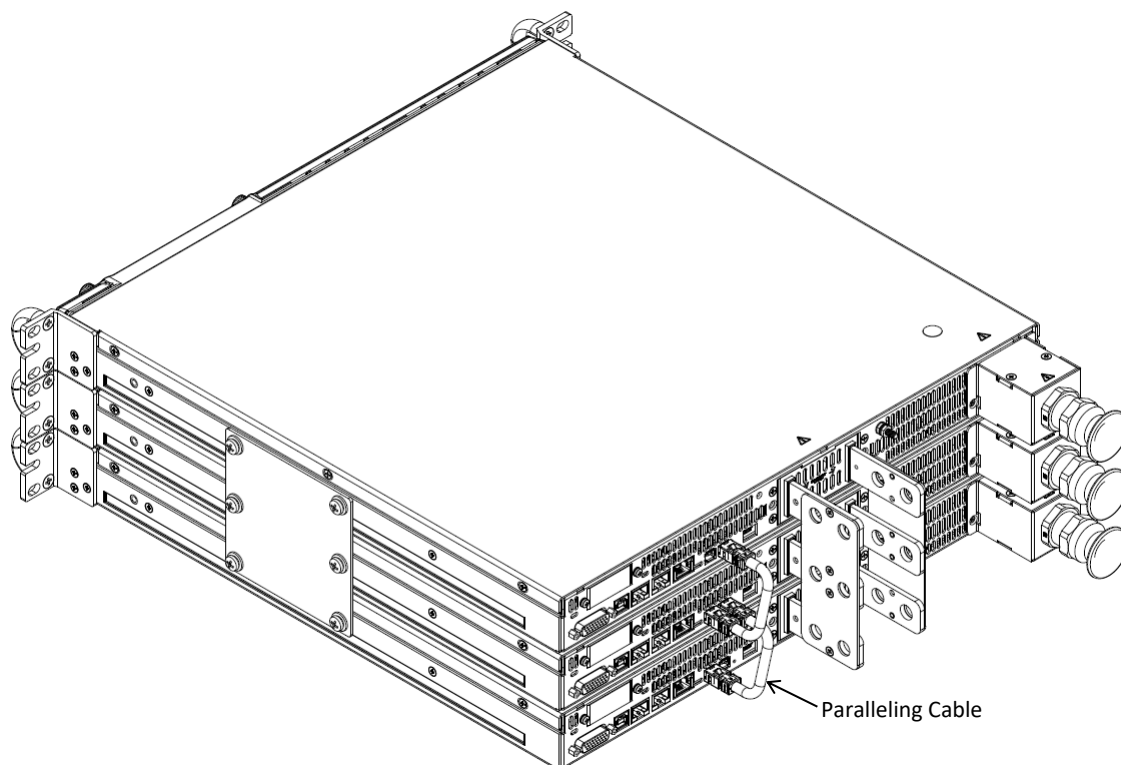

**Figure 3: Three 10V Units Paralleling Cable Connection**

4. Insert output cover through the cables as illustrated in Figure 4.

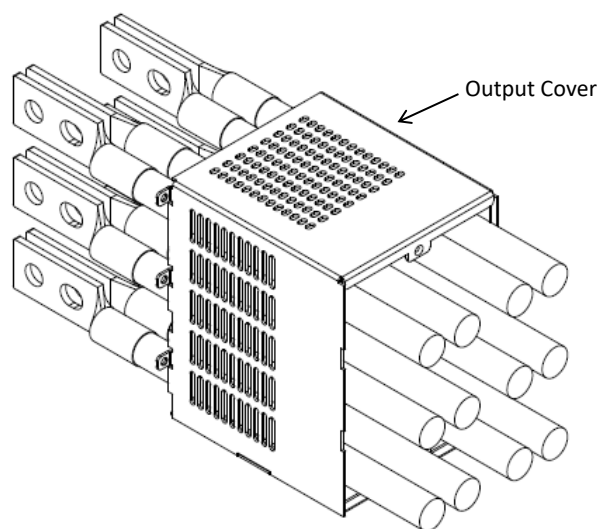

**Figure 4: Output Cover Insertion**

- Assemble two lugs on each bus bar, one on each side, using two hexagon bolts, four plain washers, two helical spring-lock washers and two hexagon nuts as illustrated in Figure 5.

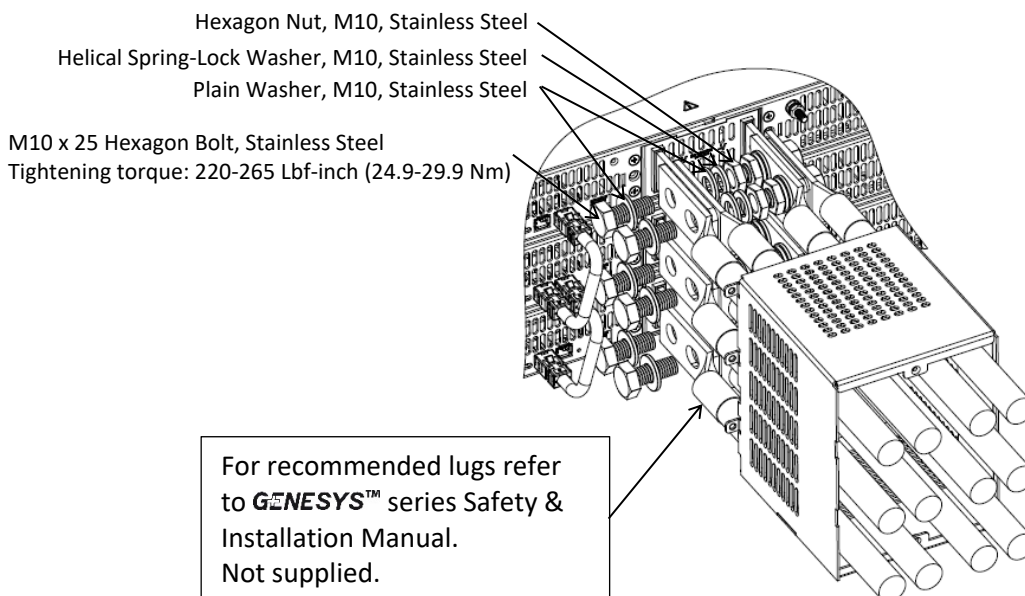

**Figure 5: Three 10V Units Lugs Assembly**

- Assemble bus bar insulator prior to output cover assembly. The insulator is flexible and could be opened in its bottom side. Open the insulator and cover the bus bar by sliding it over the bus bar, from top to bottom, as illustrated in Figure 6. Repeat for the second bus bar.

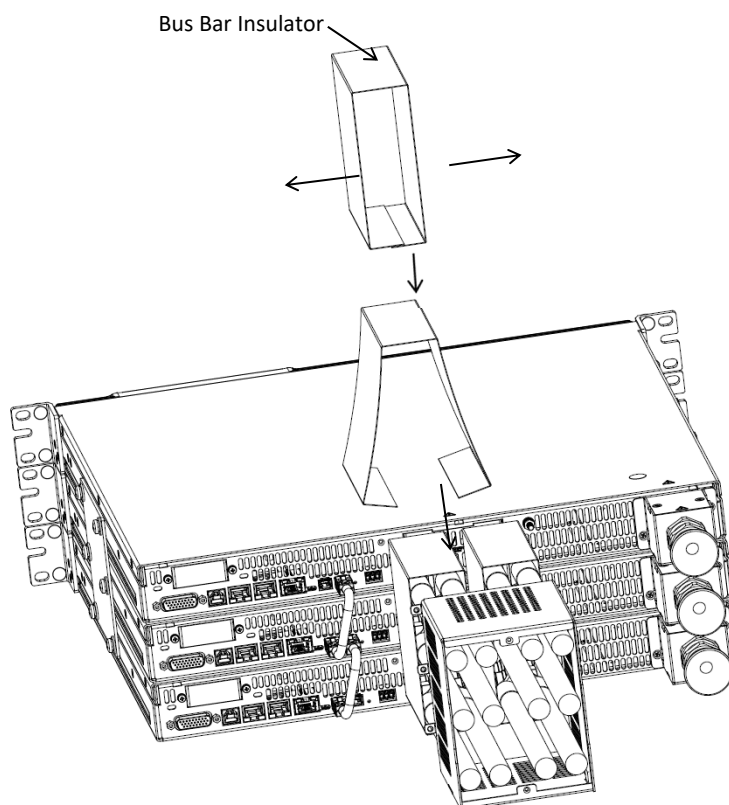

**Figure 6: Three 10V Units Bus Bar Insulator Assembly**

7. Fix output cover to the power supplies using six SEMS screws as illustrated in Figure 7.

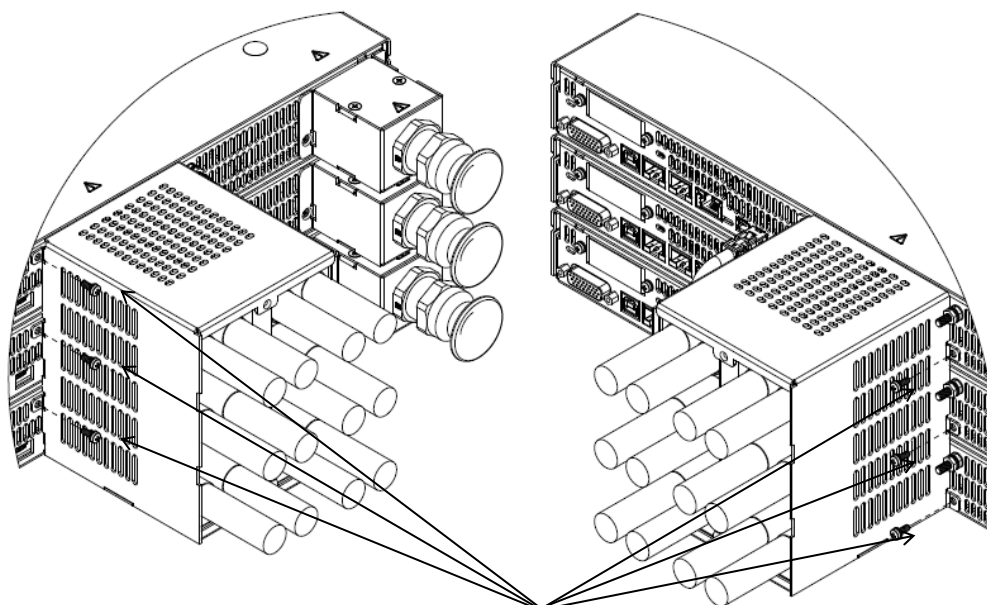

M3 x 8 SEMS Screw, Nickel Plated  
Tightening torque: 4.7-5.7 Lbf-inch (0.53-0.64Nm)

**Figure 7: Three 10V Units Output Cover Assembly**

## 1.4.2 G/P-3U-20-40V - Assembly Instructions for three 20V-40V units in Parallel

### 1.4.2.1 Components List

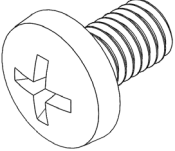

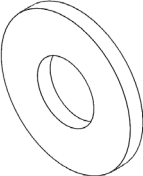
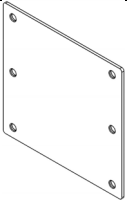
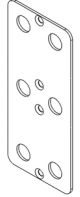
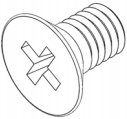
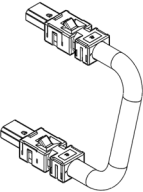
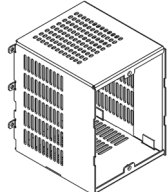
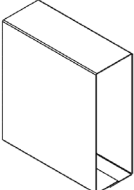

Image	Component	Quantity
	10-32 x 5/16 Pan Head Screw, Stainless Steel	12
	Helical Spring-Lock Washer, No. 10, Stainless Steel	12
	Plain Washer, No. 10, Stainless Steel	12
	Connection Plate 3U	2
	Output Short	2
	M3 x 4C Flat Head Screw, Nickel Plated	8
	Paralleling Cable	2
	Output Cover	1



Image	Component	Quantity
	Bus Bar Insulator	2
	Protection Insulator	1
	M3 x 8 SEMS Screw, Nickel Plated	8

### 1.4.2.2 Installation Steps

1. Attach connection plates, one on each side of the power supplies, using 12 pan head screws, 12 helical spring-lock washers and 12 plain washers as illustrated in Figure 8.

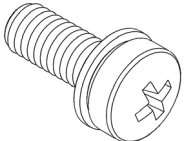
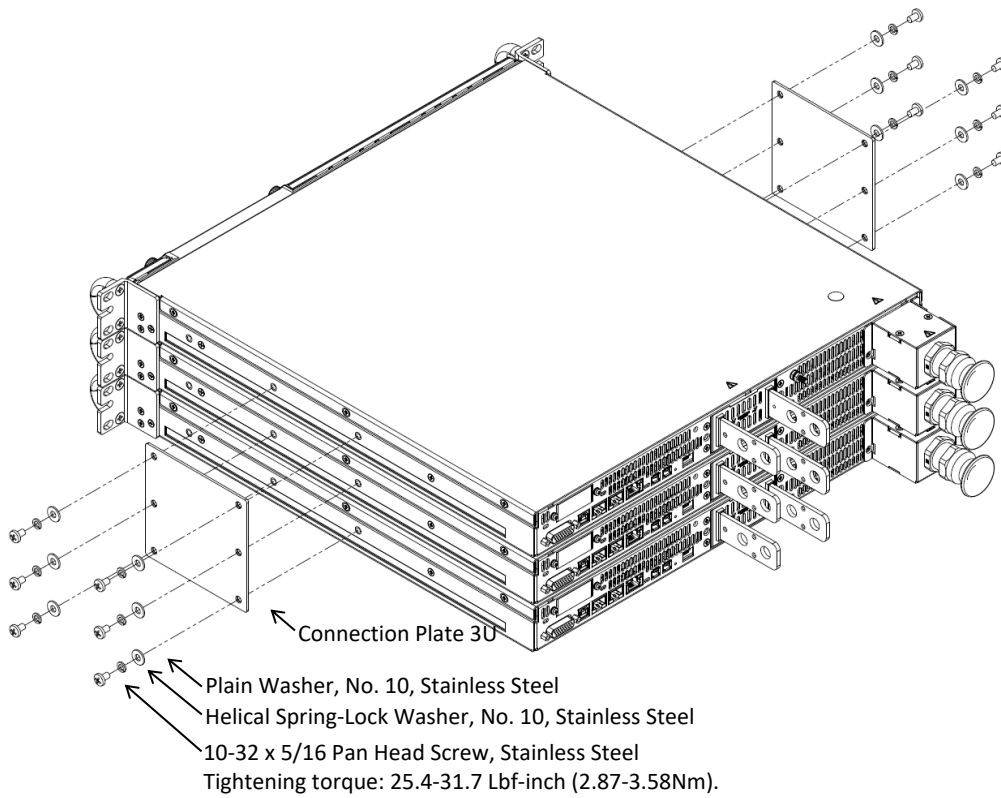

**Figure 8: Three 20V-40V Units Connection Plates 3U Assembly**

2. Attach output short plates, one on each triple of terminals, using eight flat head screws as illustrated in Figure 9.

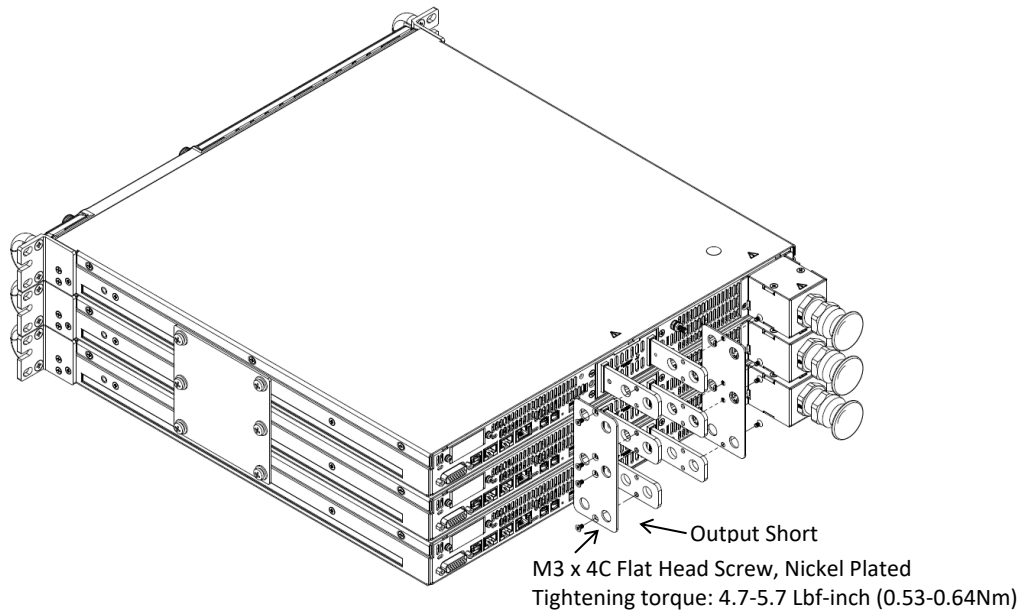

**Figure 9: Three 20V-40V Units Output Short Plates Assembly**

3. Connect two paralleling cables from top unit M connector to bottom unit S connector as illustrated in Figure 10.

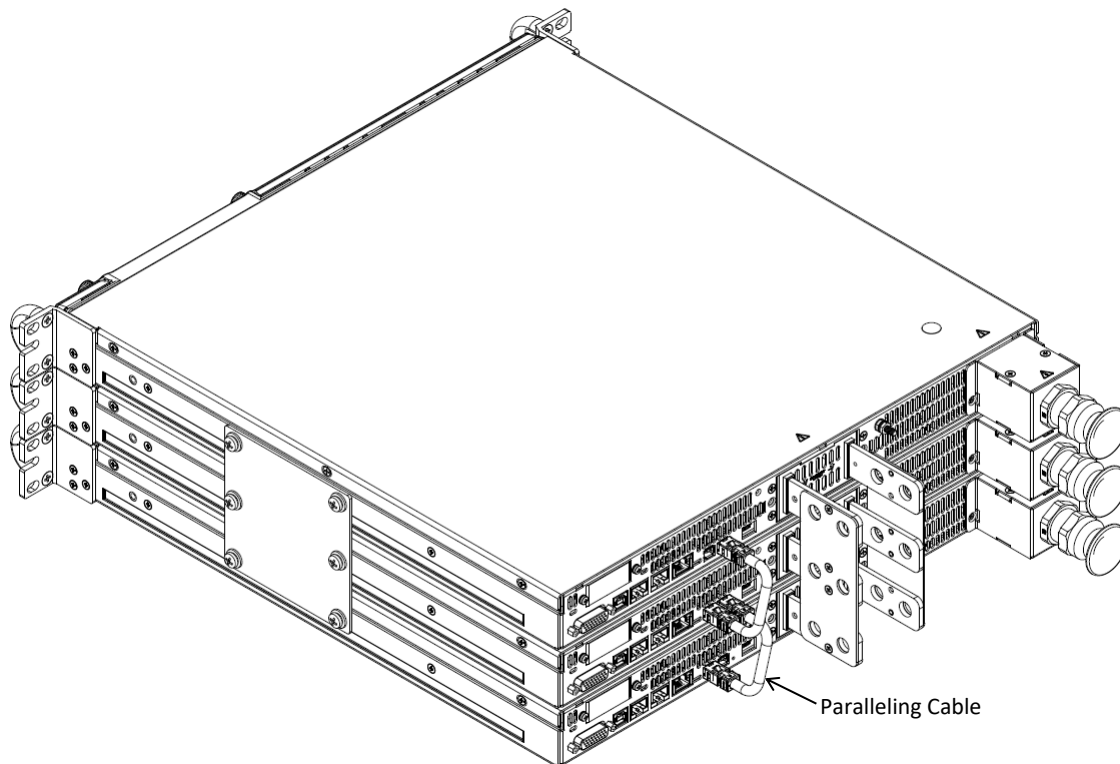

**Figure 10: Three 20V-40V Units Paralleling Cable Connection**

4. Insert output cover through the cables as illustrated in Figure 11.

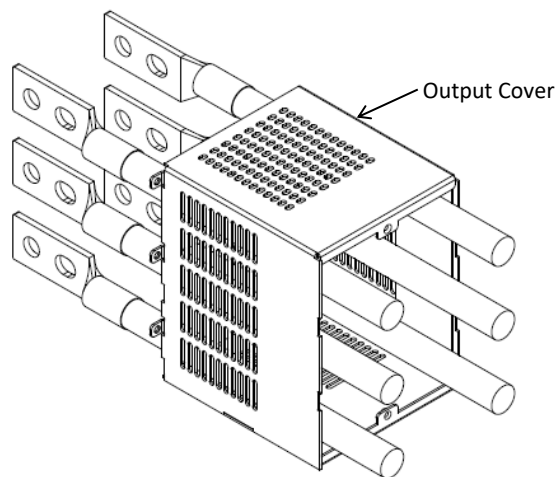

**Figure 11: Output Cover Insertion**

- Assemble one lug on each bus bar using two hexagon bolts, four plain washers, two helical spring-lock washers and two hexagon nuts as illustrated in Figure 12.

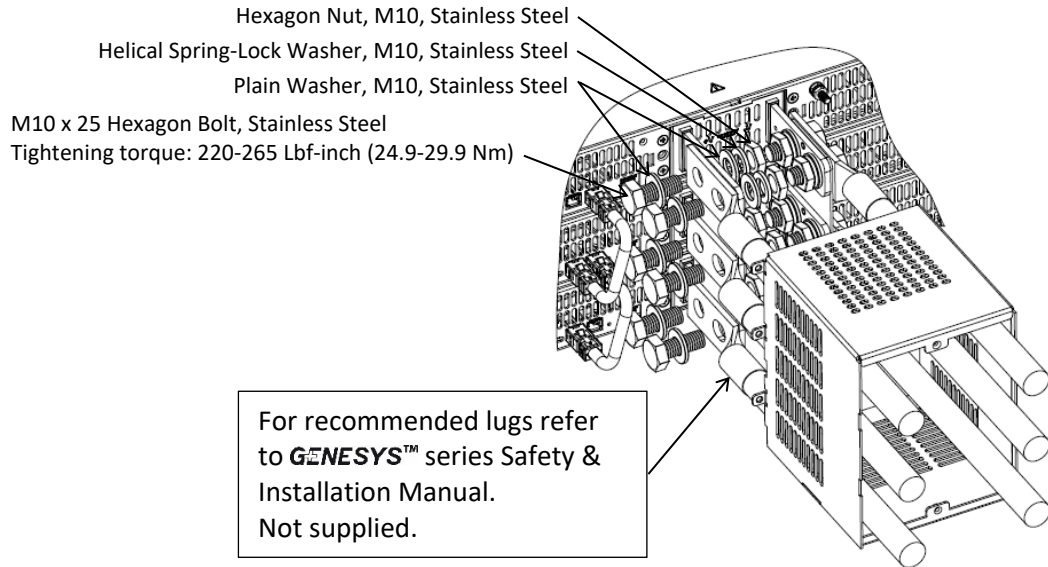

**Figure 12: Three 20V-40V Units Lugs Assembly**

- Assemble bus bar insulator prior to output cover assembly. The insulator is flexible and could be opened in its bottom side. Open the insulator and cover the bus bar by sliding it over the bus bar, from top to bottom, as illustrated in Figure 13. Repeat for the second bus bar.

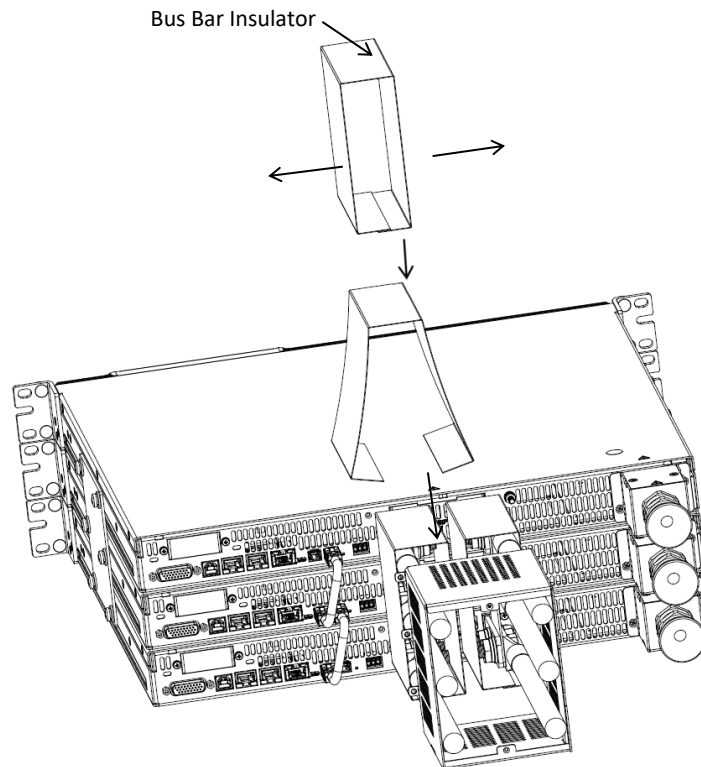

**Figure 13: Three 20V-40V Units Bus Bar Insulator Assembly**

7. Fix output cover to the power supplies using six SEMS screws as illustrated in Figure 14.

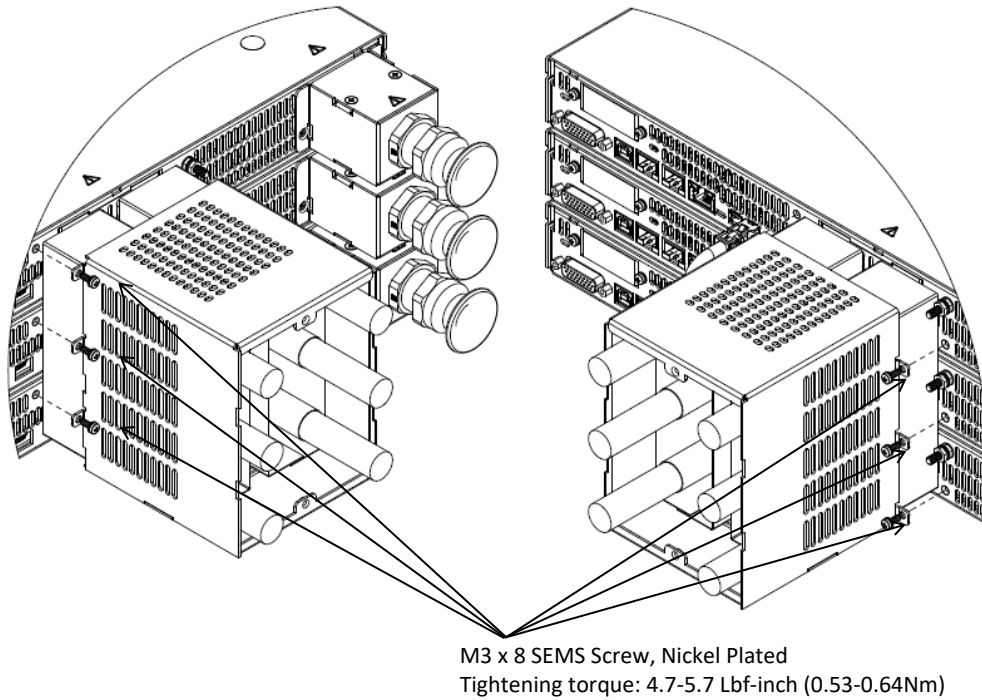

**Figure 14: Three 20V-40V Units Output Cover Assembly**

8. Fix protection insulator to the output cover using two SEMS screw as illustrated in Figure 15.

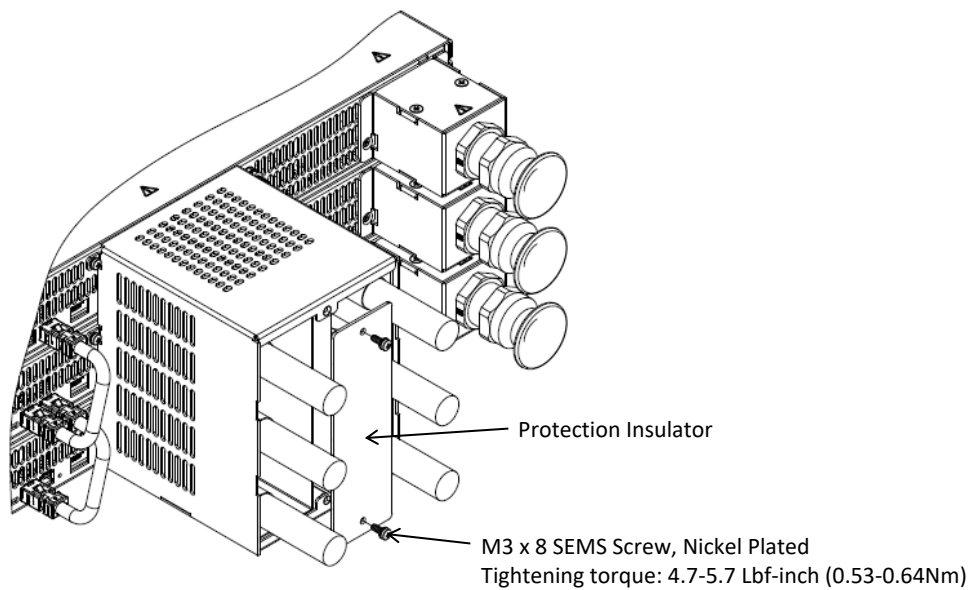

**Figure 15: Three 20V-40V Units Protection Insulator Assembly**

### 1.4.3 G/P-3U-60-100V - Assembly Instructions for three 60V-100V units in Parallel

#### 1.4.3.1 Components List

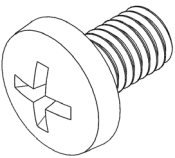

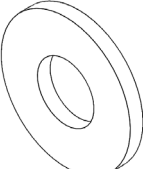
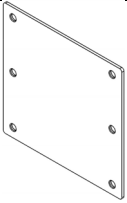

Image	Component	Quantity
	10-32 x 5/16 Pan Head Screw, Stainless Steel	12
	Helical Spring-Lock Washer, No. 10, Stainless Steel	12
	Plain Washer, No. 10, Stainless Steel	12
	Connection Plate 3U	2
	Output Short	2
	M3 x 4C Flat Head Screw, Nickel Plated	6
	Paralleling Cable	2
	Output Cover	1

Image	Component	Quantity
	Bus Bar Protection Bracket	1
	Bus Bar Cover Plug	6
	M3 x 8 SEMS Screw, Nickel Plated	8

### 1.4.3.2 Installation Steps

1. Attach connection plates, one on each side of the power supplies, using 12 pan head screws, 12 helical spring-lock washers and 12 plain washers as illustrated in Figure 16.

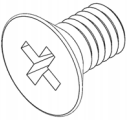
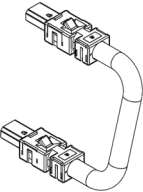
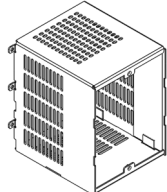
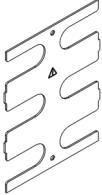
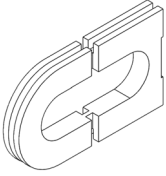
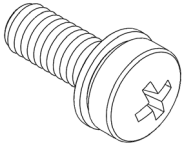
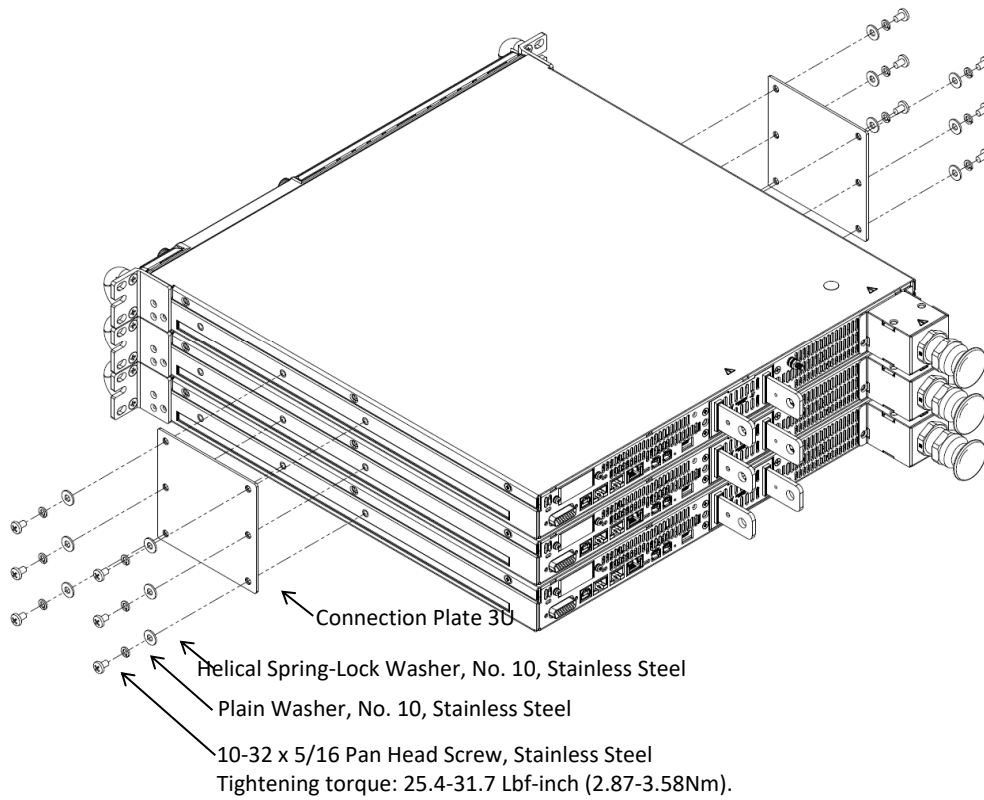

**Figure 16: Three 60V-100V Units Connection Plates 3U Assembly**

2. Attach output short plates, one on each pair of terminals, using six flat head screws as illustrated in Figure 17.

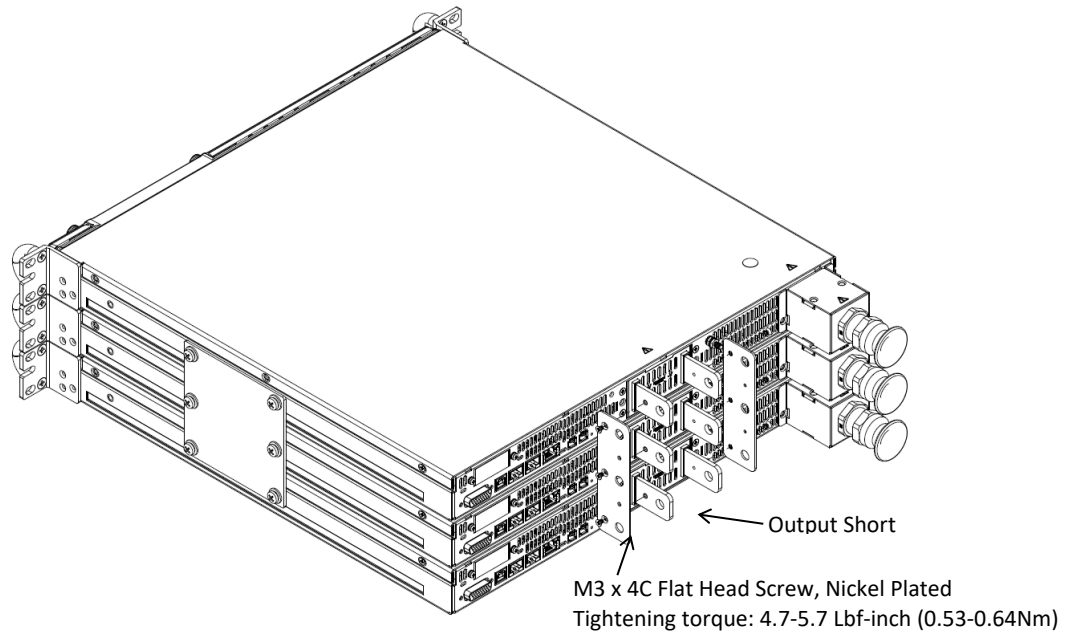

**Figure 17: Three 60V-100V Units Output Short Plates Assembly**



3. Connect two paralleling cables from top unit M connector to bottom unit S connector as illustrated in Figure 18.

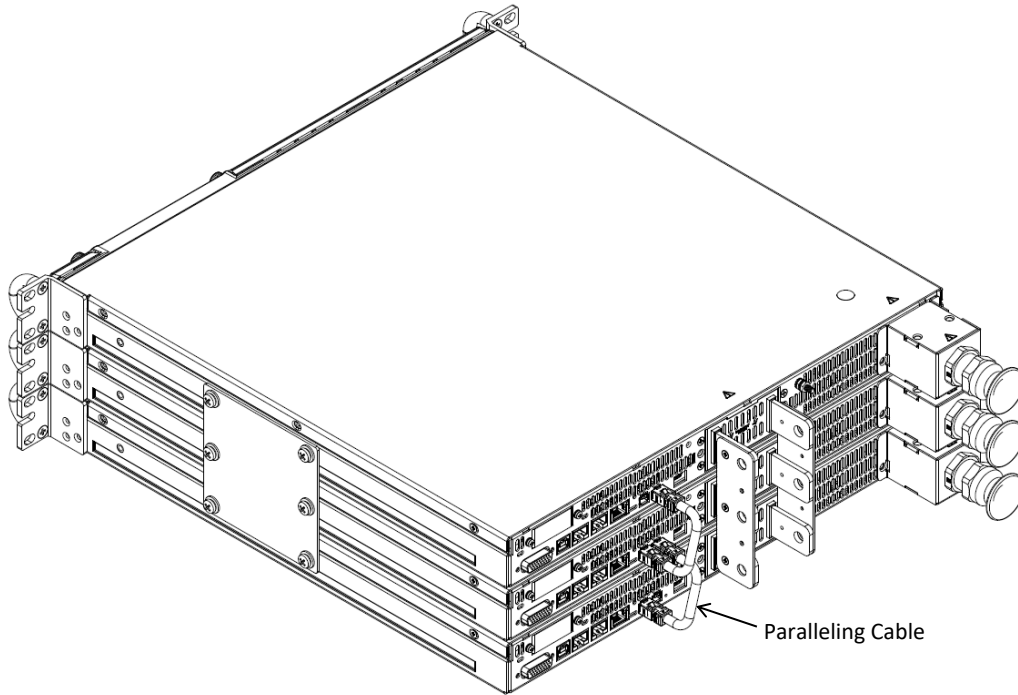

**Figure 18: Three 60V-100V Units Paralleling Cable Connection**

4. For load wires with a diameter smaller than or equal to 11 millimeter insert six bus bar cover plugs into the bus bar protection bracket and fix it to the output cover using two SEMS screw. Insert output cover assembly through the cables as illustrated in Figure 19.

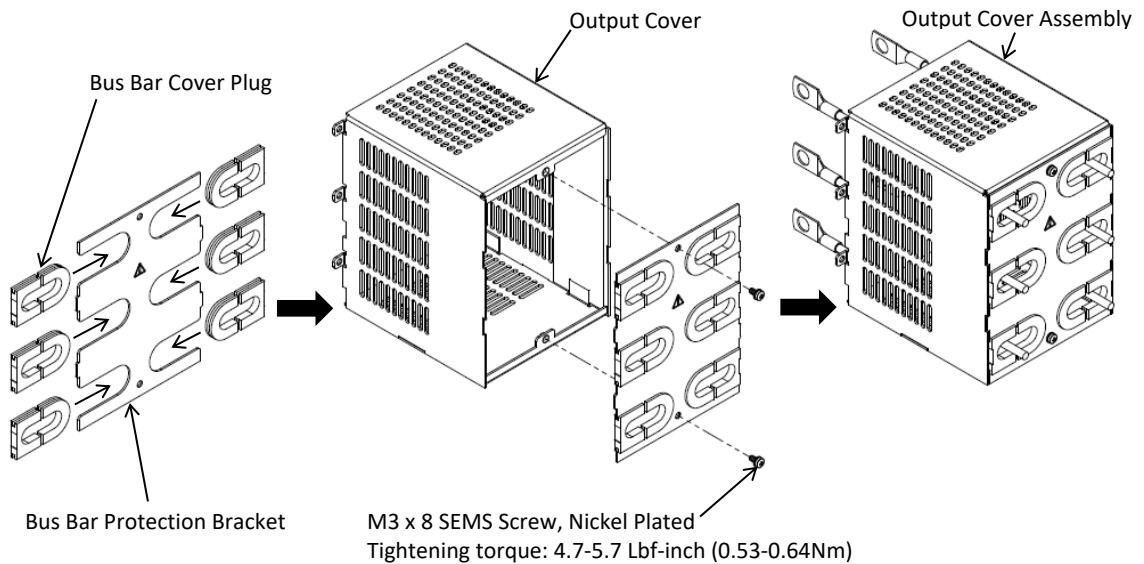

**Figure 19: Three 60V-100V Units, Wire Diameter  $\leq$  11mm, Output Cover Assembly**

- For load wires with a diameter greater than 11 millimeter divide each bus bar cover plug into two separate parts by bending and breaking it along its separate grooves, as illustrated in Figure 20. Insert only the rounded parts into the bus bar protection bracket and fix it to the output cover using two SEMS screw. Insert output cover assembly through the cables as illustrated in Figure 20.

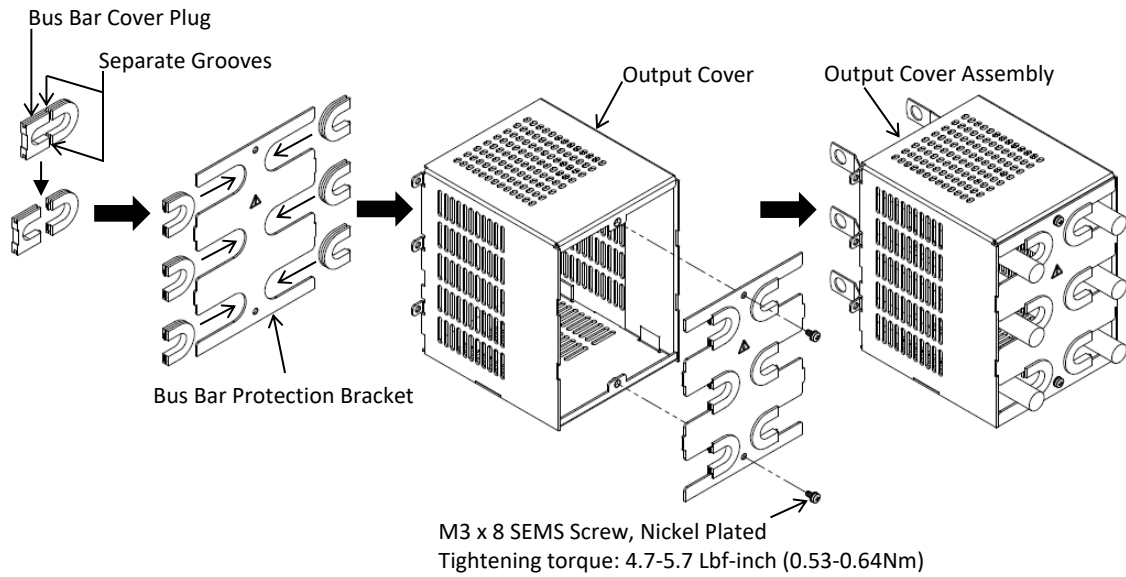

**Figure 20: Three 60V-100V Units, Wire Diameter > 11mm, Output Cover Assembly**

- Assemble one lug on each bus bar using one hexagon bolt, two plain washers, one helical spring-lock washer and one hexagon nut as illustrated in Figure 21.

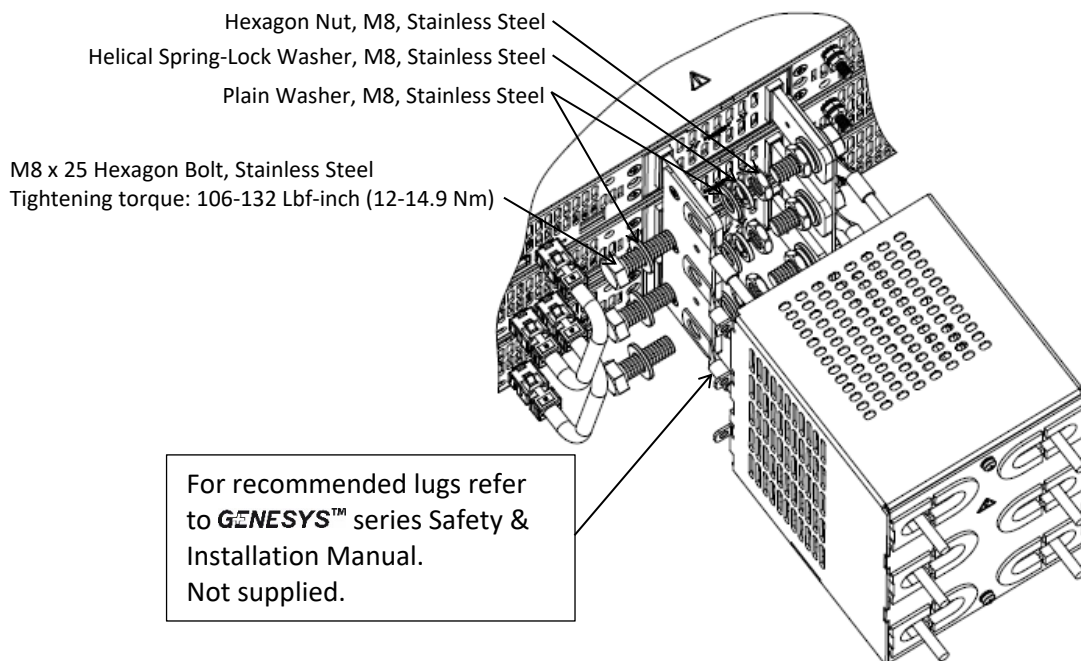

**Figure 21: Three 60V-100V Units Lugs Assembly**

7. Fix output cover to the power supplies using six SEMS screws as illustrated in Figure 22.

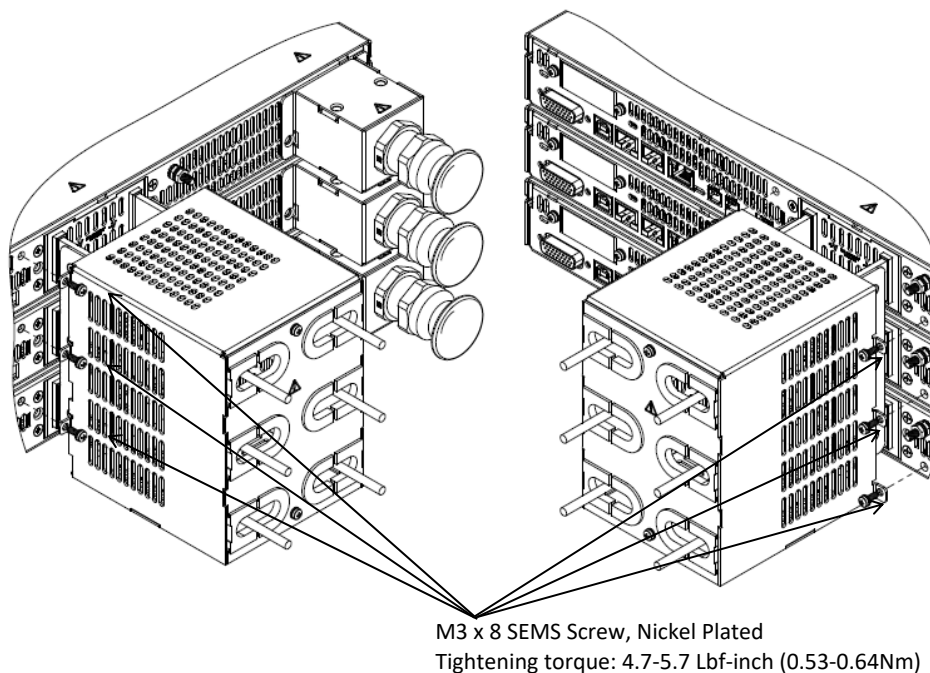

**Figure 22: Three 60V-100V Units Output Cover Assembly**

**1.4.4 G/P-3U-150-600V - Assembly Instructions for three 150V-600V units in Parallel**

**1.4.4.1 Components List**

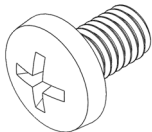

Image	Component	Quantity
	10-32 x 5/16 Pan Head Screw, Stainless Steel	12
	Helical Spring-Lock Washer, No. 10, Stainless Steel	12
	Plain Washer, No. 10, Stainless Steel	12
	Connection Plate 3U	2

Image	Component	Quantity
	Paralleling Cable	2
	Fixing Bracket	1
	M3 x 8 SEMS Screw, Nickel Plated	6
	Output Bracket G+15KW	1
	M3 x 10 SEMS Screw, Nickel Plated	4
	Output Bracket	1
	M3 x 6G Flat Head Screw, Nickel Plated	2
	Output Plug	1

### 1.4.4.2 Installation Steps

1. Attach connection plates, one on each side of the power supplies, using 12 pan head screws, 12 helical spring-lock washers and 12 plain washers as illustrated in Figure 23.

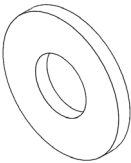
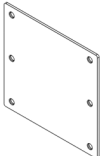
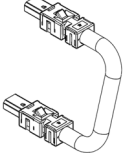
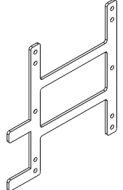
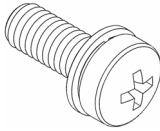
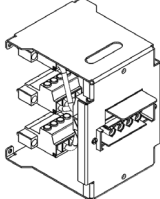
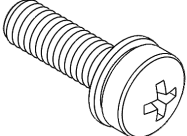
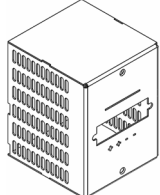
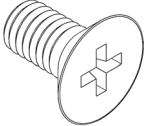
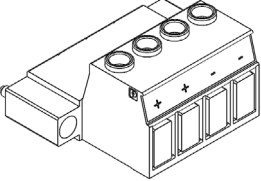
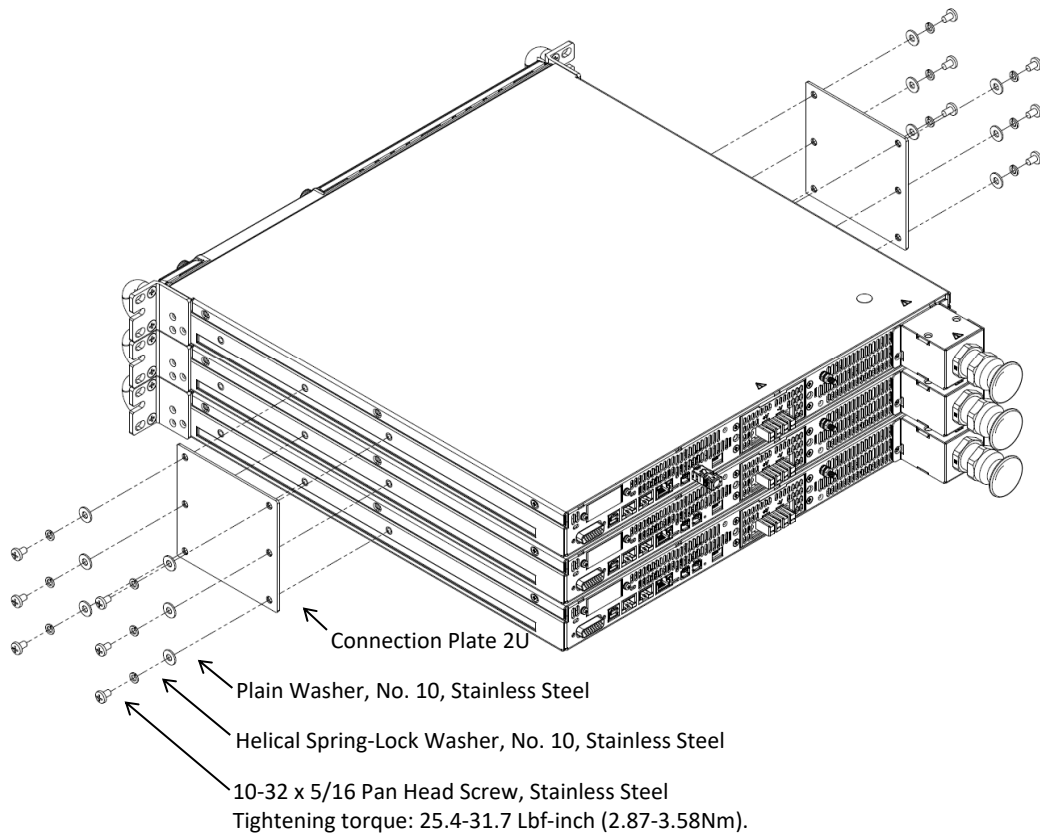

**Figure 23: Three 150V-600V Units Connection Plates 2U Assembly**

2. Loosen and remove six flat head screws from power supply's back side as illustrated in Figure 24.

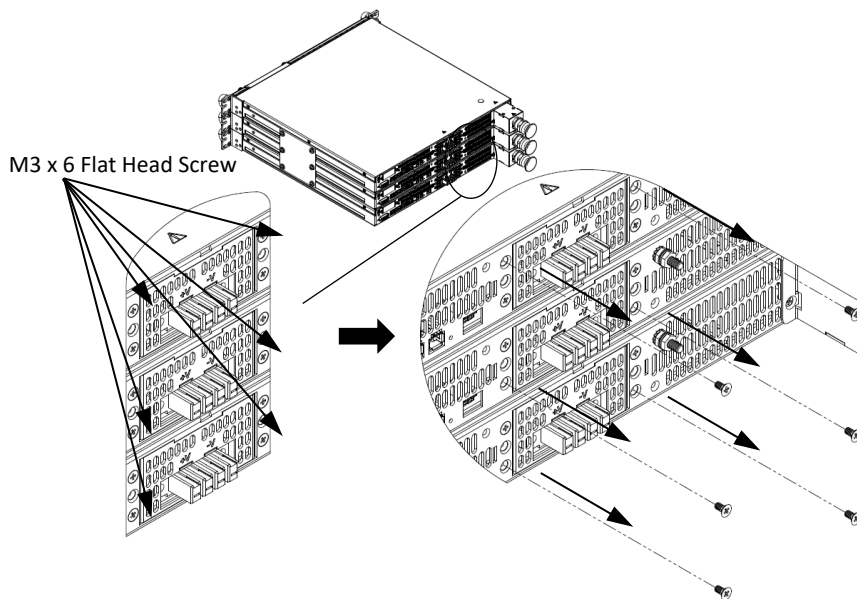

**Figure 24: Power supply's back side screws removal**

- Attach fixing bracket to power supply's back side using six SEMS screws, eight millimeter screw length, as illustrated in Figure 25. Make sure the horizontal tab is located as illustrated in Figure 25.

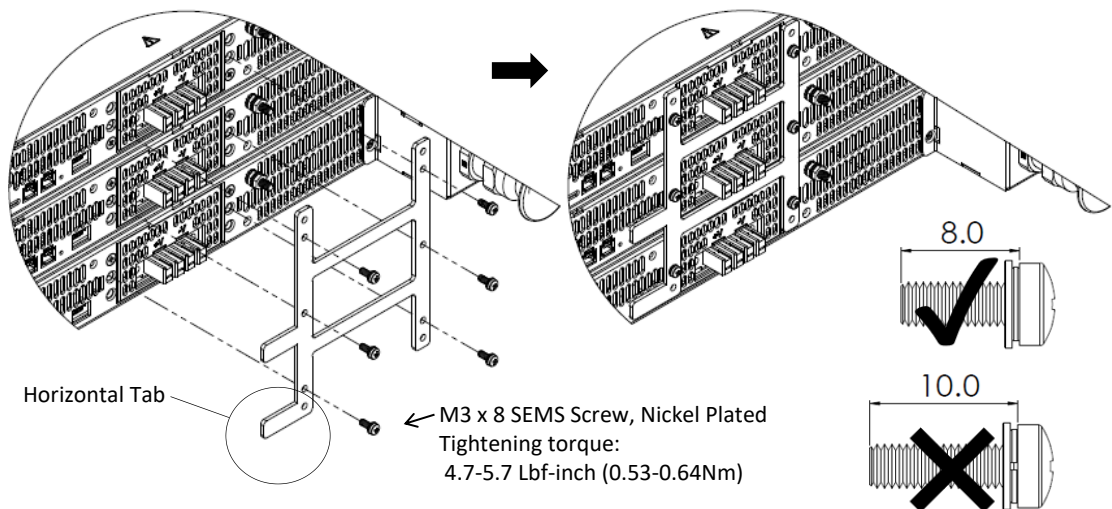

**Figure 25: Fixing bracket installation**

- Insert three plugs into their compatible output receptacle and fasten them using their six built-in screws and a slotted screwdriver as illustrated in Figure 26.

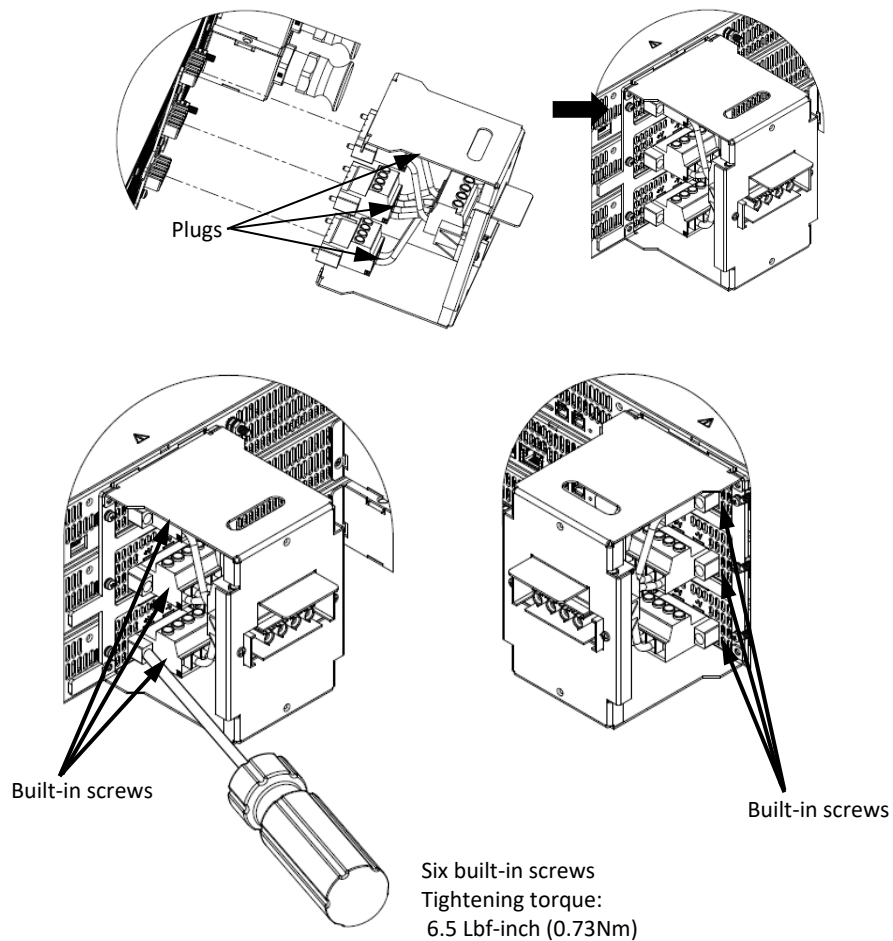

**Figure 26: Fixing bracket installation**

5. Attach output bracket G+15KW to fixing bracket using four SEMS screws, ten millimeter screw length, screws as illustrated in Figure 27.

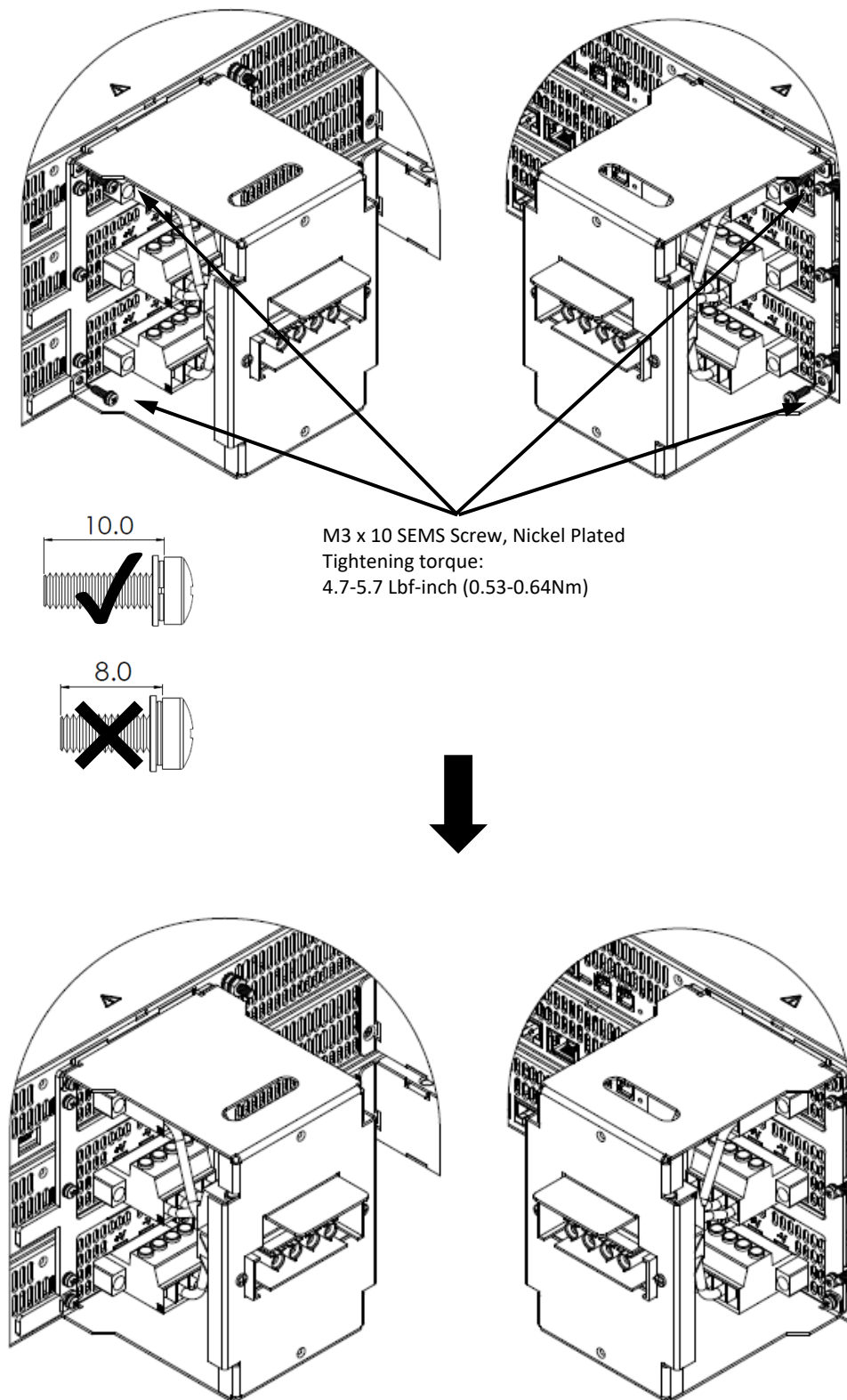
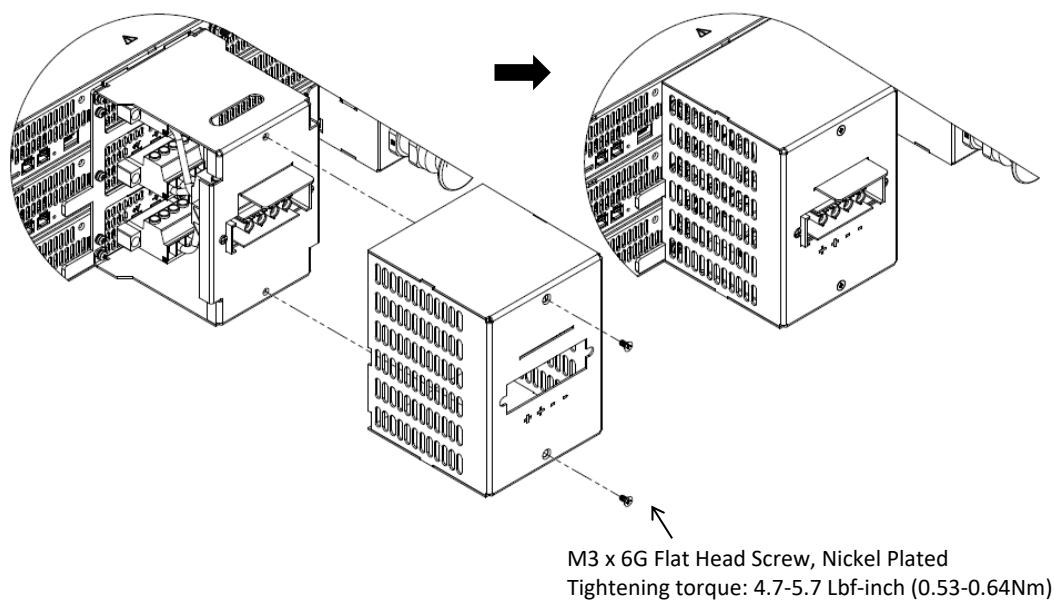

Figure 27: Output bracket G+15KW installation

6. Attach output bracket to output bracket G+15KW using two flat head screws as illustrated in Figure 28.



**Figure 28: Output bracket installation**

7. Connect two paralleling cables from top unit M connector to bottom unit S connector as illustrated in Figure 29.

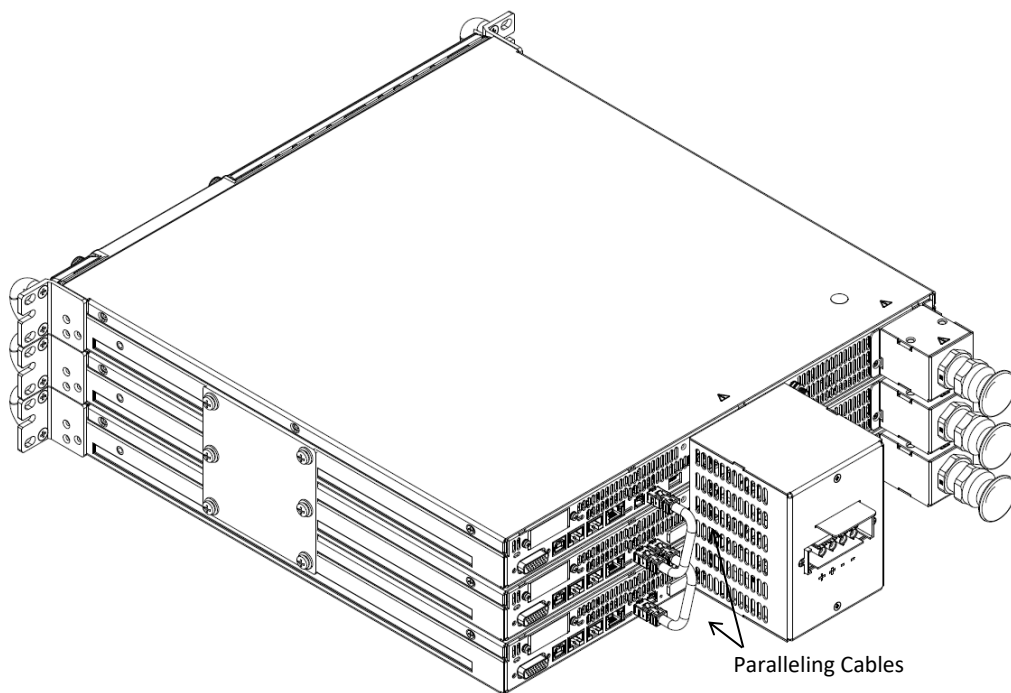

**Figure 29: Three 150V-600V Units Paralleling Cables Connection**



8. To operate the power supply use the output plug and fasten it using its two built-in screws as illustrated in Figure 30.

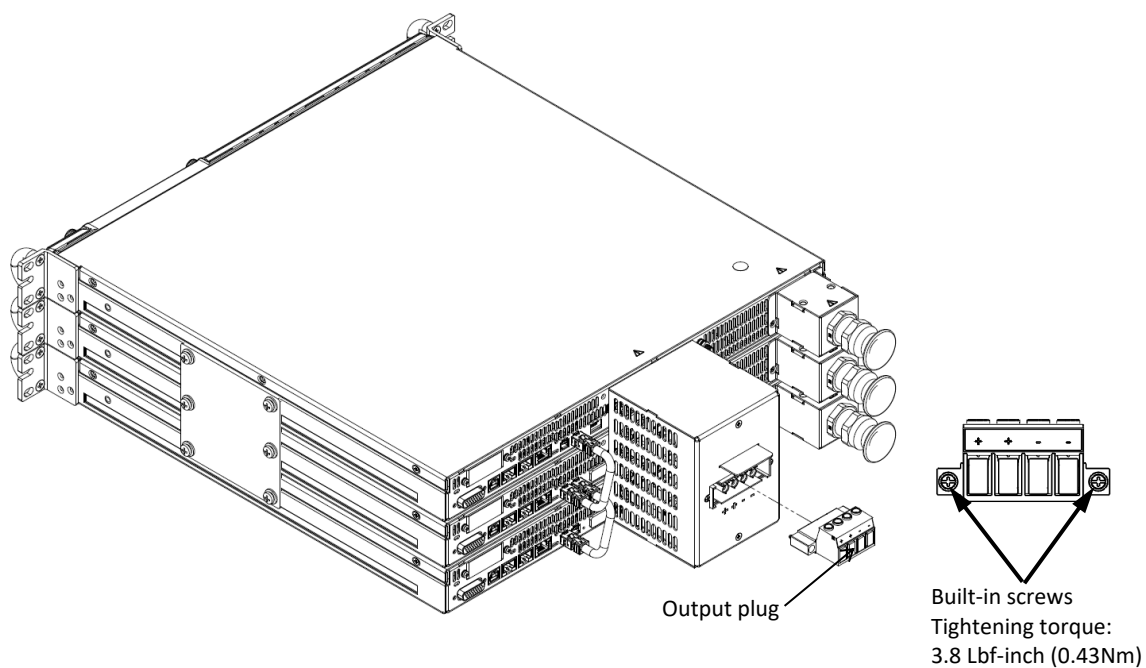

**Figure 30: Output plug**

This page intentionally left blank



