

This is uncontrolled copy when without Authorized Mark on the printed drawing. Verification of the latest version shall be conducted by PLM system.

RoHS COMPLIANCE

Surface QC

Unless otherwise specified dimensional tolerance as follows:

| DIMENSION L (mm) | TOLERANCE ±mm |
|-------------------------|------------------|
| $L \leq 16.0$ | 0.1 |
| $16.0 < L \leq 63.0$ | 0.2 |
| $63.0 < L \leq 250.0$ | 0.3 |
| $250.0 < L \leq 1000.0$ | 0.5 |

PUNCHING DIRECTION
→

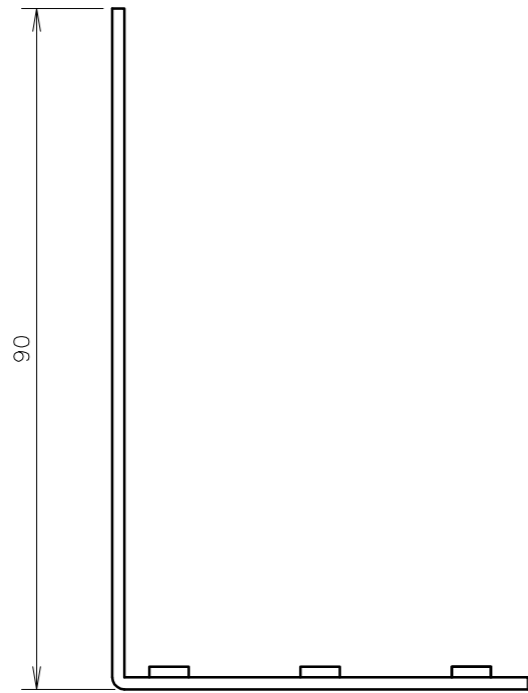

| D | REV | CONTENTS | DATE | ENGR | CHK | APPD |
|---|-----|-------------|------|------|-----|------|
| - | C43 | NEW RELEASE | | | | |

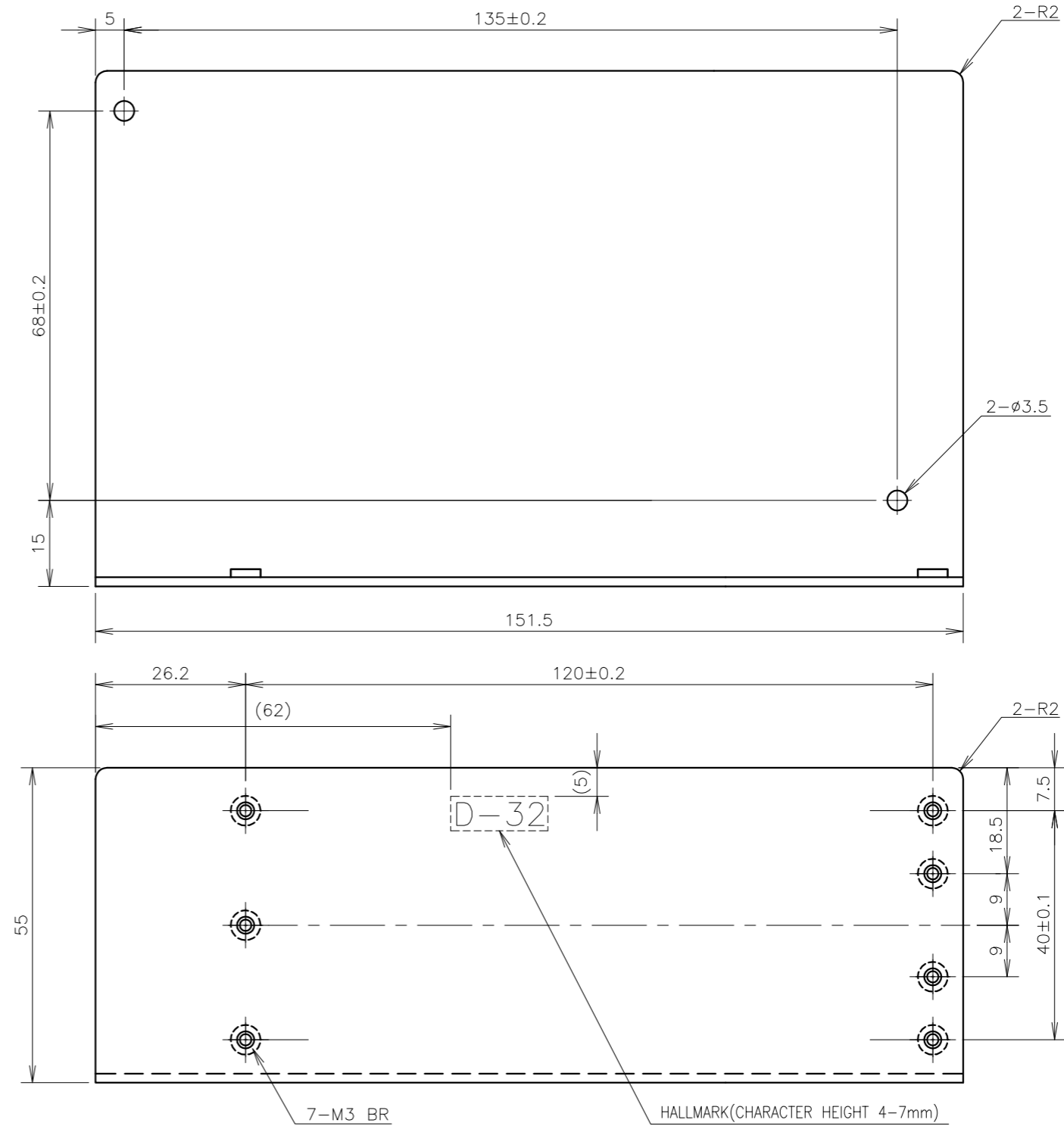

NOTE

- 1.NO BURR NO SHARP EDGES.
- 2.INSIDE RADIUS OF BEND R0.5
- 3.UNLESS OTHERWISE SPECIFIED DIMENSIONAL BENDING ANGLE : $90^\circ \pm 0.5^\circ$
- 4.TAP SHALL KEEP MORE THAN 3 THREADS.
- 5.RoHS COMPLIANCE :
REFER TO T-L GROUP GREEN PROCUREMENT GUIDELINE : DL-EMS-010_.
- 6.SURFACE QC :
REFER TO GUIDELINE FOR DEFECTS IN THE SURFACE APPEARANCE OF PRODUCTS (FOR VENDER) : NLS-B-225_

| | | | | | | |
|------|--|-------|-------------------------|------------------|-------------------|--|
| APPD | | SCALE | 1 / 1 | MATERIALS | TITLE | MS-10,MS-11,HMS80-150 |
| CHK | | UNITS | mm | SPCC-SD t=1.6 | | BRACKET |
| ENGR | | ANGLE | 3RD ANGLE PROJECTION | FINISH | DRAWING No. | 8000-3-863 <input type="checkbox"/> PAGE 1/1 |
| | | | | Ep-Fe/Ni[2] b | TDK-Lambda | |

G:\8000-3-863.dwg