



# S-parameter Data Library

**TDK Corporation**  
**Application Marketing Group**

May 16 2016

## < Applicable condition >

The data in this library is obtained under the condition of 25°C, no DC bias, and small signal operation. Proper result might not be obtained if your condition is different from the above one.

## < Terms and conditions regarding TDK Simulation Models >

1. This simulation model is being provided solely for informational purposes. Please refer to the specifications of the products in terms of detailed characteristics of such products.
2. In no event shall TDK Corporation or any of its subsidiaries be liable for any loss or damage arising, directly or indirectly, from any information contained in this simulation model, including, but not limited to loss or damages arising from any inaccuracies, omissions or errors in connection with such information.
3. Any and all copyrights on this simulation model are owned by TDK Corporation. Duplication or redistribution of this simulation model without prior written permission from TDK Corporation is prohibited.
4. This simulation model is subject to any modification or change without any prior notice.
5. Neither TDK Corporation nor any of its subsidiaries shall make any warranty, express or implied, including but not limited to the correctness, implied warranties of merchantability and fitness for a particular purpose with respect to this simulation models.
6. The use of this simulation model shall be deemed to have consented to the terms and conditions hereof.

## S-parameter is measured by using Network Analyzer.

- Test Board : Micro-strip line with 50 ohm characteristic impedance (FR4 0.4mm thick)
- Temperature : 25 degree Cel.

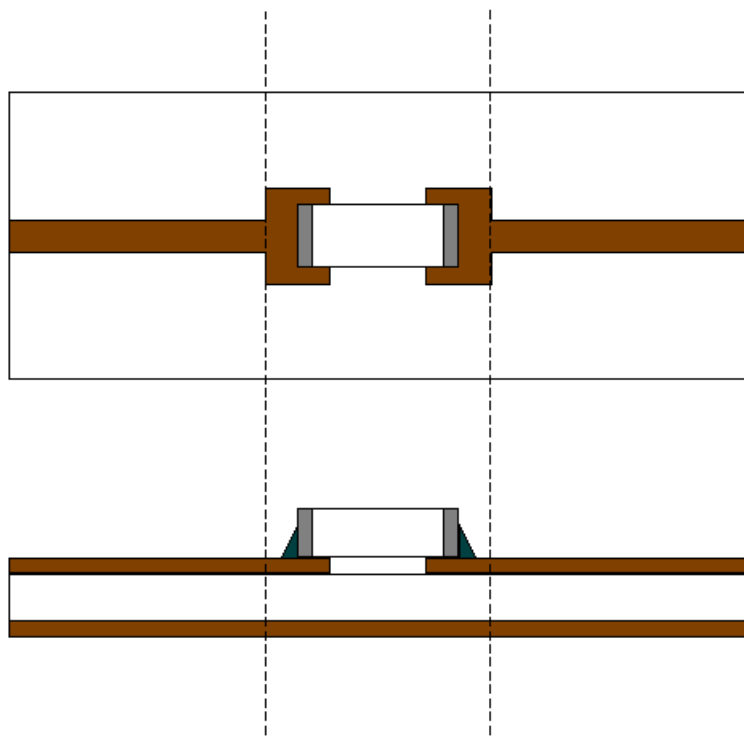

Reference Plane

An example of test board for 2-port device

- DUT is put on a micro-strip line.
- TDK's recommended land pattern is formed around the DUT.
- Reference plane is set at the edge of the land pattern by calibration.
- So measurement data include the characteristics of land pattern.
- To satisfy passivity, measured S-parameter is corrected a little.

(Note)

S-parameters of a part of chip beads, inductors and multi-layer ceramic capacitors are converted from the impedance data measured by impedance analyzer.  
S-parameters of high frequency inductors are converted from the equivalent circuit model.

# Port Assignment (1/3)

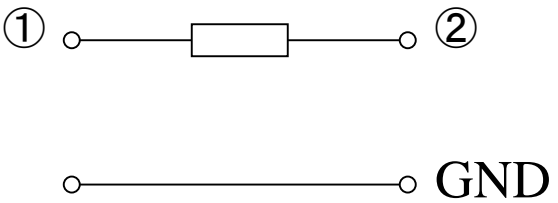
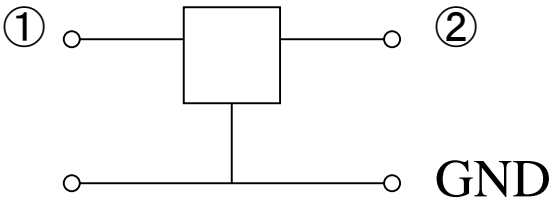
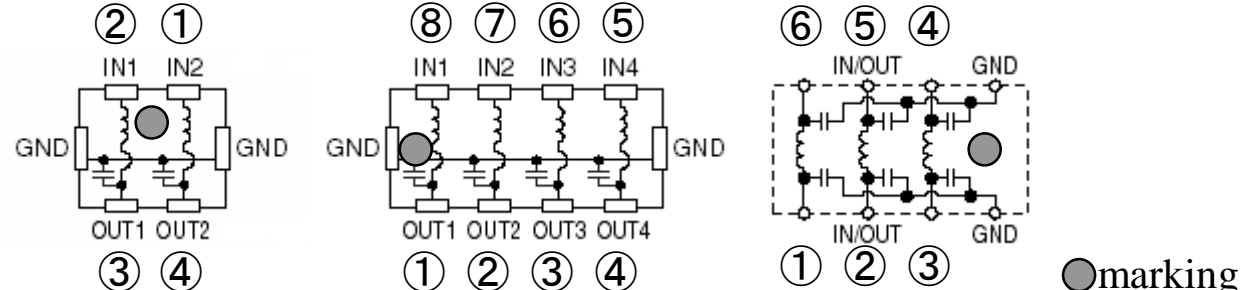
<p>2-terminal Components(*)</p>	 <p style="text-align: right;">Series-thru</p>
<p>3-terminal filter Feed-through capacitor</p>	
<p>3-terminal filter array</p>	 <p style="text-align: right;">● marking</p>

(\*)Chip Beads, Inductors, Multilayer Ceramic Chip Capacitors, Chip Varistors

<p>Common mode filter (CMF)</p>	
<p>CMF array</p>	
<p>Multi-line CMF</p>	

Balun

**HHM15,17 Series**

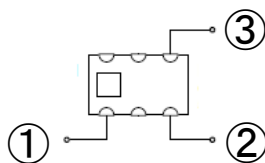

**HHM19 Series**

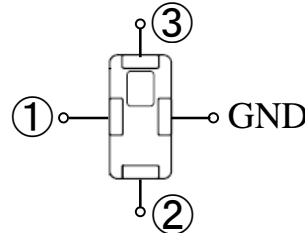

**ATB2012, TTB12G Series**

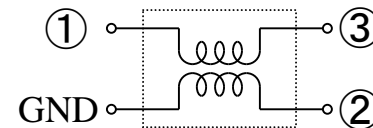

**TTB16G Series**

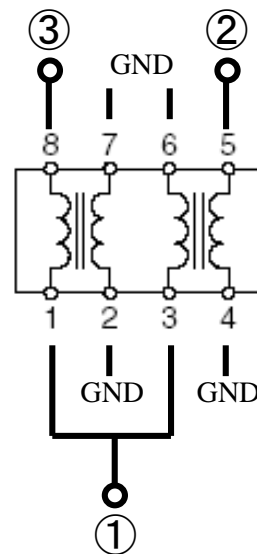

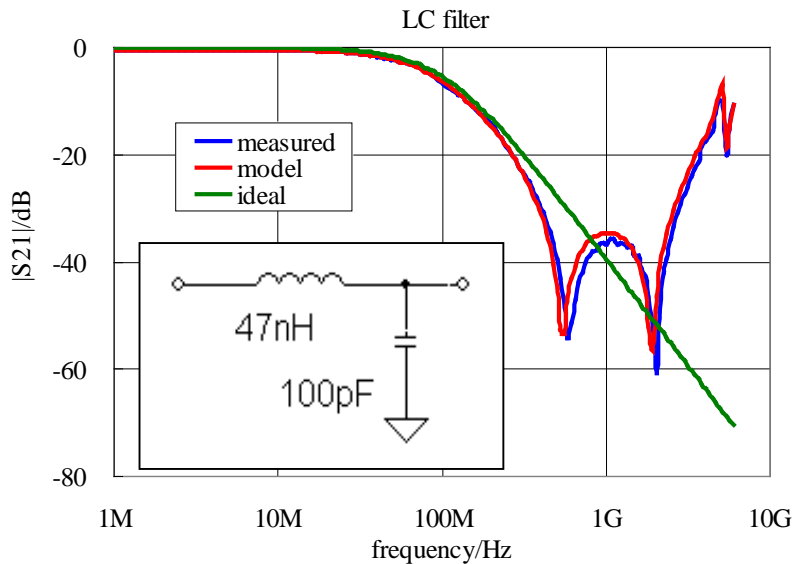

This example is of a filter composed of one inductor and one capacitor. If these elements are ideal, it is a simple low pass filter with cut-off frequency about 50MHz (green line). But the actual behavior is different. There are two poles in the attenuation band (blue line).

By using the TDK S-parameter Data Library, the two poles can be realized (red line).

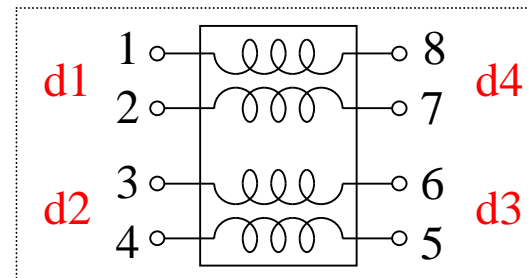
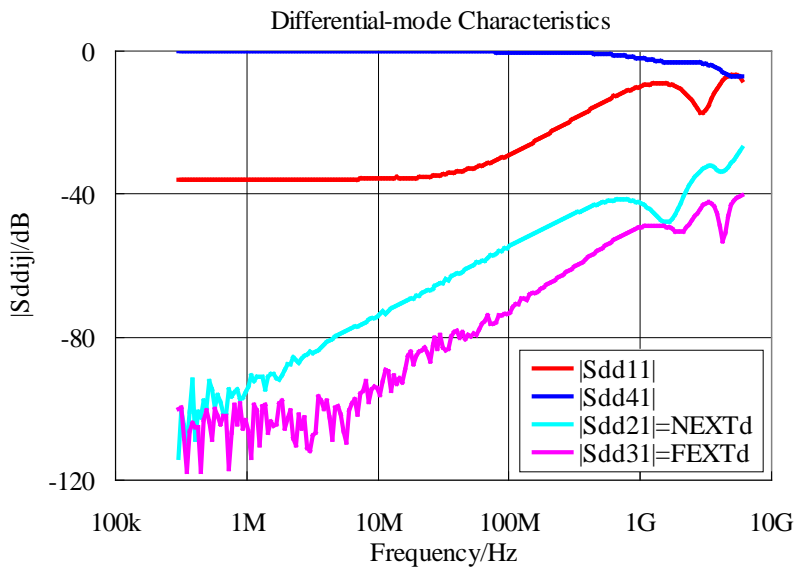

- Near end crosstalk (NEXT) of differential mode  $|S_{dd31}|$  is -55dB, and far end crosstalk (FEXT)  $|S_{dd41}|$  is -73dB at 100MHz.

S-parameter consists of a finite frequency range. So, please do NOT use it beyond the range.

Ex.  $|S_{21}|$  of a Inductor

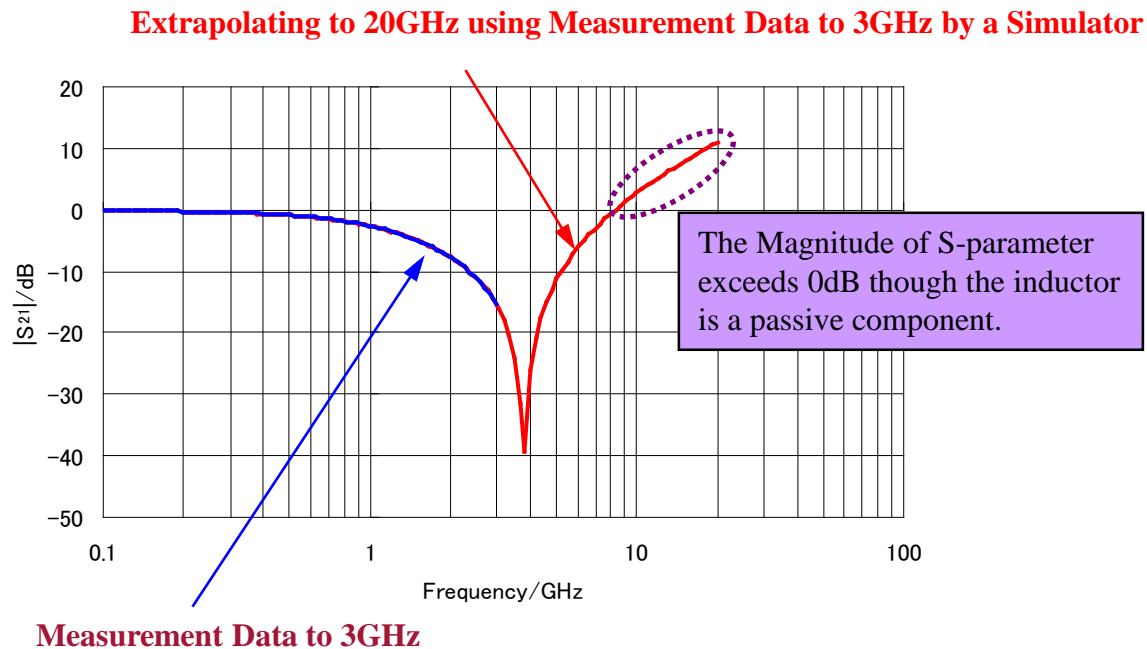



- There is no difference in S-parameter by the tolerance because TDK S-parameter Data Library uses typical data of the product.

